

# THE RANCHER™ WOOD/COAL RANGE

## MODEL SR57E OWNERS MANUAL

(save this manual for future reference)



READ ALL INSTRUCTIONS CAREFULLY BEFORE INSTALLING OR OPERATING THIS STOVE. FAILURE TO FOLLOW INSTRUCTIONS MAY RESULT IN PROPERTY DAMAGE, BODILY INJURY, OR EVEN DEATH.

THIS STOVE IS **NOT** A UL LISTED STOVE

NOTE: IT IS RECOMMENDED INSTALLATION BE COMPLETED BY A QUALIFIED HEATING EQUIPMENT INSTALLER!

REFER TO MARKINGS ON STOVE LABELS FOR ADDITIONAL INFORMATION.

**DO NOT** INSTALL IN A MOBILE HOME.

**SAFETY NOTICE: IF THIS STOVE IS NOT PROPERLY INSTALLED, A HOUSE/BUILDING FIRE MAY RESULT. FOR YOUR SAFETY, CONTACT LOCAL OR MUNICIPAL BUILDING OR FIRE OFFICIALS ABOUT PERMITS, RESTRICTIONS, AND INSTALLATION REQUIREMENTS FOR YOUR AREA.**

# VOGELZANG

*International* CORPORATION



Vogelzang International Corporation  
400 West 17th Street  
Holland, Michigan 49423  
www.vogelzang.com  
Phone: 1-616-396-1911  
Fax: 1-616-396-1971

# SAFETY INSTRUCTIONS

*Read All Instructions carefully.*

## **Read All Instructions carefully.**

1. The installation of this stove must comply with your local building code rulings. Please observe the clearances to combustibles (see reference figures 2–4 ). Do not place fuel, furniture or any other objects within the clearance area.
2. Verify that the stove is properly installed before firing the stove for the first time. After reading these instructions, if you have any doubt about your ability to complete your installation properly, you must obtain the services of a professional licensed installer familiar with all aspects of safe and correct installation. **DO NOT** use temporary or makeshift compromises during installation. There must be **NO DEVIATION OR ALTERATION OF ANY KIND** from the very specific instructions spelled out in this instruction manual as it pertains to the installation of this woodstove. **NO EXCEPTIONS!**
3. **DO NOT** store coal, wood, kindling, flammable liquids or other combustible materials in the vicinity of the appliance. Refer to label on back of unit and reference figures 3–5 in this manual.
4. **DO NOT INSTALL THIS STOVE IN A MOBILE HOME, MANUFACTURED HOME, TRAILER OR TENT NO EXCEPTIONS! (HUD Federal Standard: 24 CFR Ch.XX).**
5. **DO NOT ELEVATE THIS STOVE BY ANY MEANS.** (i.e. bricks under legs, cement blocks) Stove legs must set directly upon the solid-surface non-combustible floor as specified in this stove instruction manual.
6. **DO NOT MODIFY THIS STOVE IN ANY WAY!** Stove must be installed with legs provided, attached as shown in the instructions. Assemble only with original parts as supplied and shown in this manual.
7. **DO NOT OPERATE A STOVE THAT IS MISSING ANY PARTS!** If any parts are missing or defective, please notify the dealer or manufacturer immediately. Replace missing, broken or worn parts with factory original or equivalent parts only.
8. Do not tamper with combustion air controls beyond normal adjustment capacities.
9. Always connect this stove to a chimney and vent to the outside. Never vent to another room or inside a building. **DO NOT CONNECT THIS UNIT TO A CHIMNEY FLUE SERVING ANOTHER APPLIANCE.**
10. **DO NOT CONNECT A WOOD OR COAL BURNING STOVE TO AN ALUMINUM TYPE B GAS VENT.** This is not safe. Use approved masonry or a manufactured chimney system listed to UL 103 HT Residential Type and Building Heating Appliance Chimney. Use a 6~/152mm diameter chimney, that is high enough to give a good draft. (See specifics in Chimney Connections instructions).
11. Be sure that your chimney is safely constructed and in good repair. Have the chimney inspected by the fire department or a qualified inspector. Your insurance company should be able to recommend a qualified inspector. Chimney connector pipe must be in good condition. Replace if necessary before using stove.
12. Creosote, soot or fly ash may build up in the chimney connector and chimney and cause a house/building fire. Inspect the chimney connector and chimney twice monthly during the heating season and clean if necessary. (see Service Hints section in this manual).
13. In the event of a chimney fire, turn the air control and flue damper to closed position, leave the building and **CALL THE FIRE DEPARTMENT IMMEDIATELY!** Have a clearly understood plan on how to handle a chimney fire by contacting your local fire authority for information on proper procedures in the event of a chimney fire. After the fire is out, the chimney must be cleaned and inspected for any stress or cracks before starting another fire. Check the condition of any combustibles surrounding the chimney.
14. **DISPOSAL OF ASHES** Ashes should be placed in a steel container with a tight fitting lid and moved outdoors immediately. The closed container of ashes should be placed on a noncombustible floor or on the ground, well away from all combustible materials, pending final disposal. If the ashes are disposed of by burial in soil or otherwise locally dispersed, they should be retained in the closed container until all cinders have completely cooled. Other waste shall not be placed in this container.
15. To prevent injury, do not allow anyone to use this stove who is unfamiliar with the correct operation of the stove.
16. Do not operate stove while under the influence of drugs or alcohol.
17. The special paints used on your stove may give off some smoke and an odor while they are curing during the first 12 to 15 fires. Additional smoke and odor may be emitted from the light oils used in construction of the fire box. This should disappear after a short period of time and not occur again. Persons with lung conditions or owners of susceptible domestic pets (such as birds) should take prudent precautions. Open windows and doors as needed to clear smoke and/or odor. Paint discoloration will occur if the stove is over fired.

*continued on next page*

## ***SAFETY INSTRUCTIONS continued...***

18. This stove has a painted surface which is durable but it will not stand rough handling or abuse. When installing your stove, use care in handling.
19. Clean exterior with soap and warm water when stove is not hot. Do not use any acids or scouring soap, as these solvents wear and dull the finish.
20. **CLEAN STOVE FREQUENTLY** as soot, creosote and ash may accumulate. Empty ash pan frequently. Buildup of ash can block air flow to the fire and/or damage the grate. Dispose of ash properly (see #14.)
21. **ALERT ALL PERSONS TO THE HAZARDS OF HIGH SURFACE TEMPERATURES** while stove is in operation – especially young children. Keep away from a hot stove to avoid burns or clothing ignition.
22. **NEVER LEAVE SMALL CHILDREN UNSUPERVISED WHEN THEY ARE IN THE SAME ROOM AS THE STOVE.** If small children will be in the same room as the stove during operation, provide a sturdy barrier to keep them at a safe distance from the stove.
23. Keep stove area clear and free from all combustible materials, gasoline, engine oil, naphtha and other flammable vapors and liquids.
24. **WHILE TENDING THE FIRE ALWAYS WEAR PROTECTIVE CLOTHING**, fire retardant hearth gloves and eye protection, to prevent burns.
25. Never operate this stove without the ash cleanout door open or ash drawer removed. Such actions can result in very dangerous operating conditions.
26. **DO NOT OVER FIRE THE STOVE.** Over firing will occur if combustion air is uncontrolled as when ash cleanout door is left open during operation. Such actions can result in very dangerous operating conditions. While in operation, keep the ash cleanout drawer in place and the ash door closed and secured at all times except while tending the fire.
27. Do not load the fuel to a height or in such manner that it would be hazardous when opening the lids.
28. **NEVER LEAVE THE STOVE UNATTENDED** when the door is open. Always close the door after ignition.
29. **DO NOT CONNECT TO OR USE IN CONJUNCTION WITH ANY AIR DISTRIBUTION DUCT WORK UNLESS SPECIFICALLY APPROVED FOR SUCH INSTALLATIONS.**
30. **THIS STOVE MUST NEVER BE INSTALLED IN A HALLWAY OR NEAR A STAIRCASE**, as it may block egress in the event of a fire.
31. **DO NOT INSTALL IN AN ALCOVE OR INSIDE A FIREPLACE.**
32. Install at least one smoke detector on each floor of your home. Detectors should be located away from the heating appliance to avoid false alarms. Detectors should be located close to sleeping areas. Follow the smoke detectors manufacturer's placement and installation instructions. Maintain smoke detector per manufacturer's instructions.
33. **CARBON MONOXIDE (CO) HAZARD.** A buildup of CO fumes is toxic and can be fatal. Carbon Monoxide is a colorless, odorless gas produced during combustion of wood, coal, oil, gas and by other fuel burning appliances. It is important to have a proper draft and adequate replacement air ventilation so fumes are drawn out the chimney. Installed as instructed this stove is designed to be as safe as possible yet it is recommended to **install a CO detector**. Follow the manufacturer's recommendations for proper installation and use. It is recommended to be placed at table-top level (not near the ceiling) to avoid false alarms. Realize that devices other than a stove (i.e. motor exhaust) can trigger CO alarms.  
**If alarm sounds:**
  - Recognize the symptoms of CO poisoning (headaches, nausea & drowsiness).
  - Increase ventilation (open windows & doors).
  - Make sure stove doors and/or lids are closed and secured.
  - Check stove for smoking or puffing (open airflow controls).
  - Check chimney & connector pipe for leaks, blockage or down-draft conditions.
  - Check CO device for false alarm.
34. Keep power cords, electrical appliances and/or assemblies outside of the clearance area shown in this manual for combustible materials.
35. Consult your municipal building department or fire officials about restrictions, permits and installation requirements for your area.
36. For further information on using your stove safely, obtain a copy of the National Fire Protection Association (NFPA) publication, "Using Coal and Wood Stoves Safely" NFPA No. HS-10-1978. The address of the NFPA is Batterymarch Park, Quincy, MA 02269.

**NOTE: A PROFESSIONAL, LICENSED HEATING AND COOLING CONTRACTOR MUST BE CONSULTED IF YOU HAVE QUESTIONS REGARDING THE INSTALLATION OF THIS SOLID FUEL BURNING APPLIANCE.**

# ASSEMBLY INSTRUCTIONS

**NOTICE:** Vogelzang International Corp. grants no warranty, stated or implied, for the installation or maintenance of your wood stove and assumes no responsibility of any incidental or consequential damages.

TOOLS REQUIRED		MATERIALS REQUIRED	
Safety Glasses	Screwdrivers (blade and phillips types)	(NOTE: The following items are NOT included with your stove)	
Hearth Gloves	13mm Nut Driver or Ratchet with 13mm Socket (for 13mm Hex Nuts)	Flooring Protection: 56" x 59" as specified (see page 4)	Chimney: Existing 6" Lined Ma- sonry Chimney or 6" Inside Dia. manufactured chimney system listed to UL 103 HT.
Pencil	13mm Nut Driver or Ratchet with 13mm Socket (for Stove Bolts)	Chimney Connection: 6" black steel (24 ga. min.) straight or elbow (as required)	Furnace Cement (manufacturer recommends Rutland Code 78 or equivalent)
6 foot Folding Rule or Tape Measure		1/2" Sheet Metal Screws	
Tin Snips			
Drill: Hand or Electric			
1/8" dia. Drill Bit (sheet metal screws)			

**CAUTION: STOVE IS HEAVY. MAKE SURE YOU HAVE ADEQUATE HELP AND USE PROPER LIFTING TECHNIQUES WHENEVER MOVING STOVE.**

Refer to diagram and parts lists at back of this manual.  
Refer to diagram and parts lists at back of this manual.

1. Uncrate the stove and remove cardboard packing and protective poly bag. (Save cardboard for further assembly.)
2. Remove parts from inside of stove. Parts include: four lids (#1), three lid supports (#4 & #5), one ash door (#14), one lid lifter (#16), four legs (#15), hardware pack (#17), and Spring Handle (#12) and draft damper (#18).
3. Place flattened carton on floor and carefully turn stove over onto carton.
4. Attach the legs to base of stove with stove bolts.
5. Carefully lift stove upright and place in desired location (see following instructions for properly locating stove).
6. Place lid supports and four lids in position on stove top.
7. Lower ash door into position.
8. The flue pipe **draft damper** (#18) must be installed into the top end of the first straight section of stove pipe (fig.1) exiting the stove **before** the stove is used.

- a. Drill two 1/4" holes centered on either side of the pipe section 6" from the top end of the pipe (figure 1).
  - b. Remove the handle from the damper then slide the damper into the pipe.
  - c. Align the damper with the holes drilled in step 8a and insert the handle through the holes and the damper.
- NOTE: THIS DAMPER IS NECESSARY FOR THE PROPER OPERATION OF THE STOVE AND TO MEET EPA EMISSIONS REQUIREMENTS FOR HEATING APPLIANCES. IT MUST BE INSTALLED BEFORE USE. (NO EXCEPTIONS)**
9. Attach stove piping — see instructions on page 5.

**DRAFT DAMPER**  
**(must be installed**  
**before use — NO**  
**EXCEPTIONS!)**

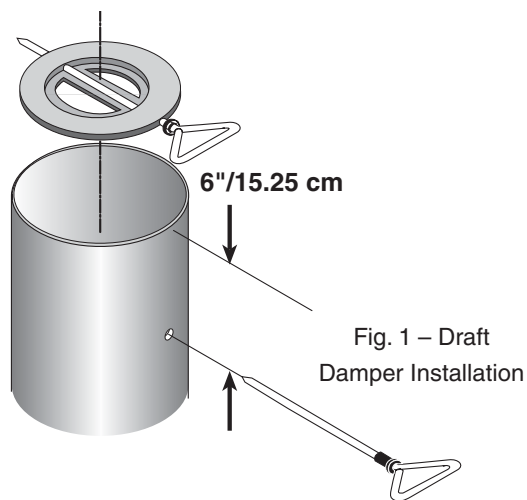

# LOCATING STOVE

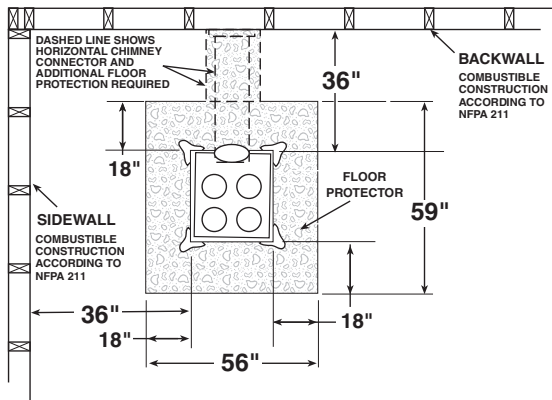
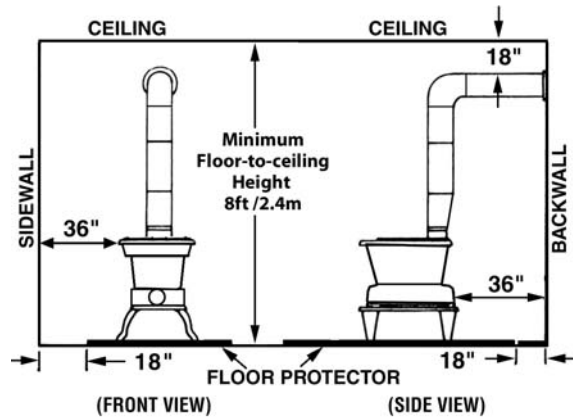

Fig. 2 Minimum Clearance Dimensions from Combustible Surfaces Fig. 3



Proper clearances must be maintained for adequate air circulation. Adequate ventilation must be provided while operating this stove.

1. The stove must be placed on solid concrete, solid masonry, or when installed on a combustible floor a solid surface floor protector listed to UL1618 Type 2 with a minimum of 1" thick and a R-value of 3.0 or greater, such as Hy-C or Imperial Model UL 5460BK must be used. (NOTE: To calculate R-values of equivalent alternative materials, see page 15). The base must extend at least 18" beyond the front, rear and sides of the stove, and **must** extend underneath and 2" beyond each side of horizontal connector pipe if it is elbowed towards a wall (see figure 5 and consult local building codes and fire protection ordinances.)
2. The stove must have its own flue. **DO NOT CONNECT THIS UNIT TO A CHIMNEY FLUE SERVING OTHER APPLIANCES.**
3. After observing the clearances to combustible materials (figure 2 – 4), locate your floor protector accordingly (figure 2) and carefully place the stove in your selected location. Install stove pipe, elbows, and thimble as required, utilizing either a recently cleaned and inspected 6"/152mm masonry chimney or a

6"/152mm i.d. masonry chimney system listed to UL 103 HT. Maximum 64 square inches.

4. Use 6"/152mm diameter minimum 24 MSG Black or 26 MSG Blue round stove pipe. **DO NOT USE GALVANIZED duct pipe.** Secure pipe sections with three (3) sheet metal screws in each stove pipe and/or elbow joint to firmly hold the pipe sections together. Screws may be no more than a maximum of 3"/76mm apart. **DO NOT CONNECT THIS STOVE TO ANY AIR DISTRIBUTION OR DUCT SYSTEM.**
5. Recheck clearances from the stove, connector stove pipe, and corner clearances using the illustrations (figure 2, 3 & 4) and your local building codes or fire protection ordinances.  
**NOTE:** Drywall faced with brick or stone **MUST** be considered a combustible surface.
6. **DO NOT INSTALL THIS STOVE IN A MOBILE HOME, MANUFACTURED HOME, TENT OR TRAILER. (NO EXCEPTIONS)**
7. The clearances provided are minimum dimensions. Installation of this stove must comply with your local building code rulings.
8. This stove is NOT a UL listed stove.

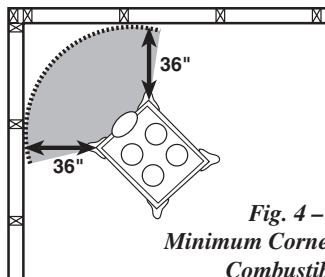

Fig. 4 - Top View Minimum Corner Clearances from Combustible Surfaces

## MINIMUM CLEARANCES TO COMBUSTIBLE SURFACES

Unit to Sidewall.....	36 inches
Unit to Backwall.....	36 inches
Unit Corner to Wall.....	36 inches
Pipe Connector to Backwall.....	38 inches
Pipe Connector to Ceiling.....	18 inches

Continued on next page



# CONNECTOR PIPE INSTALLATION

**NOTE: CONNECTOR PIPE IS *NOT* INCLUDED. TO PURCHASE PIPE, VISIT YOUR LOCAL HARDWARE, HOME OR BUILDING CENTER. SEE "LOCATING STOVE" PAGE 4 FOR ADDITIONAL SPECIFICATIONS.**

- The smooth end of the stovepipe fits over the cast iron flue collar at top rear of stove (fig. 5).
  - Crimped end of pipe must be away from stove.
  - Hand form lower end (fig. 6) of stove pipe to oval shape (fig. 7) and slide over flue outlet collar as shown in figure 5.
  - Secure stove pipe to flue collar with at least three (3) sheet metal screws and seal with stove cement.
- Horizontal pipe runs must slope upwards towards the chimney at least 1/4" per foot of horizontal run.
- You must have at least 18 inches of clearance between any horizontal piping and the ceiling.
- The pipe cannot extend into the chimney flue (figure 8).
- Secure pipe/elbow sections with three (3) sheet metal screws at each joint to make the piping rigid. Screws may be no more than a maximum of 3"/76mm apart.
- It is recommended that no more than two (2) 90 degree bends be used in the stovepipe installation. The use of more than two 90 degree bends may decrease the amount of draw and possibly cause smoke spillage. Where possible, use only corrugated (nonadjustable) elbows. These provide a better seal.
- The connector pipe must not pass through an attic or roof space, trusses, closet, or any concealed space, or floor, ceiling, wall or combustible construction. (See Chimney Connector

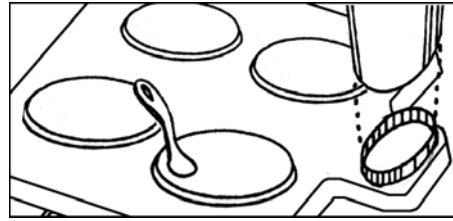

Fig. 5 – Flue Outlet Collar

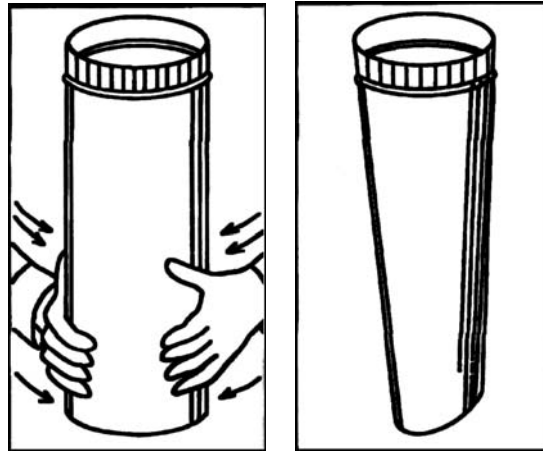

Fig. 6 – Hand-form pipe to oval shape – Fig. 7

Systems & clearances, page 10.) A UL 103 HT Listed chimney system **must** be used from the first penetration of ceiling or wall to the chimney cap. Use chimney components from a single manufacturer. Do not mix brands.

**WARNING: DO NOT USE SINGLE WALL CONNECTOR PIPE AS A CHIMNEY - A HOUSE FIRE COULD RESULT.**

**CAUTION: KEEP FURNISHINGS AND OTHER COMBUSTIBLE MATERIALS AWAY FROM THE STOVE.**

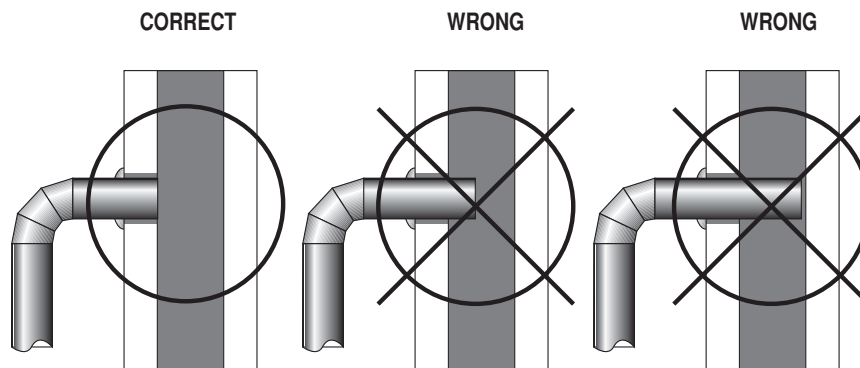

Fig. 8 – Stovepipe/Flue Connections

# CHIMNEY CONNECTIONS

The stove must be connected to either a masonry or manufactured metal chimney built and tested to the specifications listed on the previous pages.

Chimneys perform two functions:

- 1). As a means of exhausting smoke and flue gases which are the result of fuel combustion.
- 2). The chimney provides “draft” which allows oxygen to be continuously introduced into the appliance, so that proper combustion is possible. This stove relies on natural draft to operate.

**NOTICE: Always provide a source of fresh air into the room where the stove is located. Failure to do so may result in air starvation of other fuel burning appliances and the possible development of hazardous conditions, fire or death.**

**DRAFT: Your stove itself does not create draft. Draft is provided by the chimney.** To achieve proper draft your chimney must meet the three minimum height requirements detailed in figures 10–13. A minimum of 0.05 w.c. (measured in water column) is required for proper drafting to prevent back puffing, smoke spillage, and to maximize performance. Draft must not exceed 0.06 w.c. or unsafe operating conditions may occur. A barometric draft regulator must be installed if draft exceeds 0.06 w.c. (Gauges to measure draft are readily available at stove stores and are economical to rent or purchase.)

Factors such as wind, barometric pressure, trees, terrain and chimney temperature can have an adverse effect on the draft. The manufacturer cannot be held responsible for external factors leading to less than optimal drafting.

Should you have a problem with inadequate draft, you should contact a licensed heating and cooling contractor for assistance in solving the problem.

## IMPORTANT Installation Points

1. Size chimney flue to stove collar. This stove requires a 6” diameter flue.
2. Never connect this unit to a chimney serving another appliance.
3. The chimney must meet all minimum height requirements.
4. Never use a chimney to ventilate a cellar or basement.
5. Contact your local building authority for approved methods of installation and any necessary permits and/or inspections.

## MASONRY CHIMNEY

Before using an existing masonry chimney, clean the chimney, inspect the flue liner and make any repairs needed to be sure it is safe to use. Make repairs before attaching the stove. The connector stove pipe and fittings you will need to connect directly to a masonry chimney are shown in figure 9.

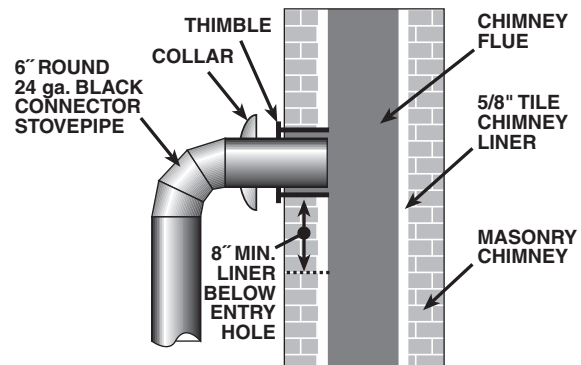

Fig. 9 - Masonry Chimney Connection

If the connector stove pipe must go through a combustible wall before entering the masonry chimney, consult a qualified mason or chimney dealer. The installation must conform to local building and fire codes and latest edition of NFPA 211.

If there is a cleanout opening in the base of the chimney, close it tightly.

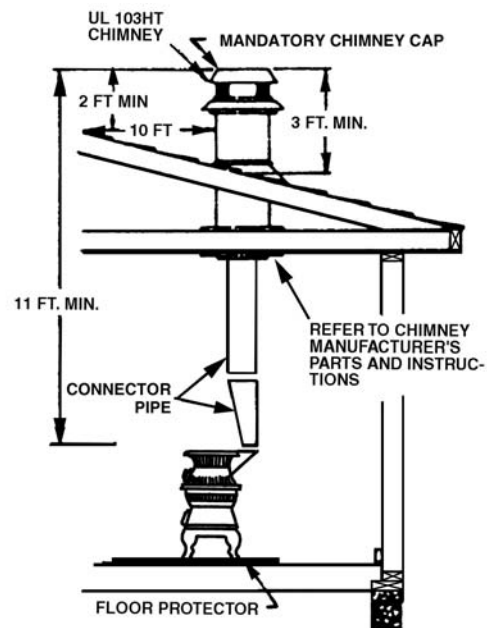

Fig. 10 - Chimney Construction Through Attic Space

# CHIMNEY CONNECTIONS *continued ...*

## MANUFACTURED CHIMNEY

REFER TO CHIMNEY AND CHIMNEY CONNECTOR MAKER'S INSTRUCTIONS FOR INSTALLATION AND USE.

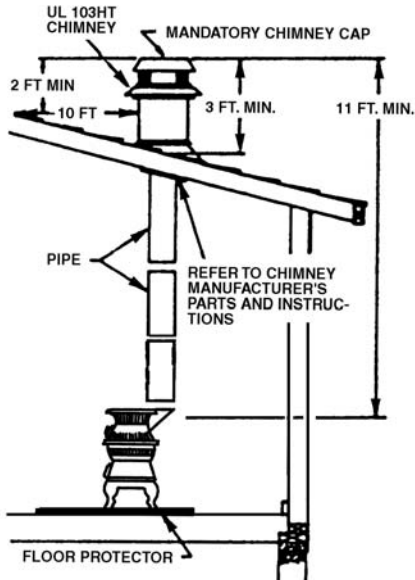

Fig. 11 - Chimney Construction Through Roof

Use only a 6" diameter manufactured chimney system listed to UL 103 HT. Chimney made to this listing is High Temperature rated to 2100 degrees Fahrenheit. Use chimney from only one manufacturer. Never mix brands. Carefully follow the chimney manufacturer's stated requirements and clearances. Use the chimney manufacturer's attic guards, roof supports, flashing and fire stops when passing through a ceiling. Use a listed

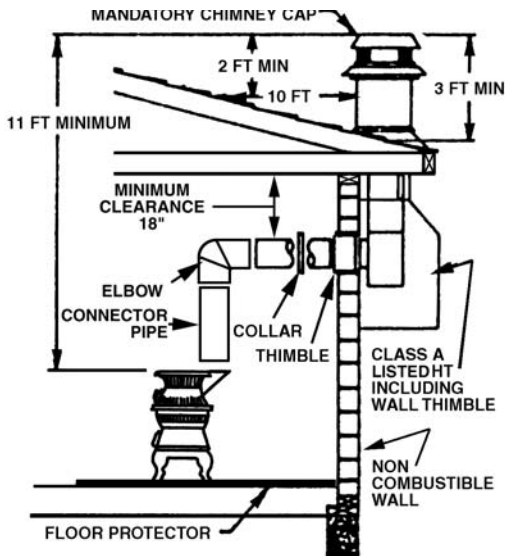

Fig. 12 - Chimney Connection to Fireplace Through Masonry Wall

thimble when passing through a combustible wall. Do not use makeshift compromises during installation.

**WARNING: DO NOT USE SINGLE WALL CONNECTOR PIPE AS A CHIMNEY - A HOUSE FIRE COULD RESULT.**

When using a pre-existing chimney, have its condition and installation inspected before using. Make sure that the chimney meets all of the UL rating requirements listed above. Be aware that not all manufactured chimney is of the UL 103 HT type.

NOTE: It is recommended that you contact a licensed heating and cooling contractor (consult your local yellow pages) for chimney installation.

Manufactured chimney with the proper required UL listing is available from most home centers, hardware stores, and HVAC supply stores.

If you have access to the internet, you may wish to view chimney manufacturers' information on-line. See, [www.duravent.com](http://www.duravent.com), [www.selkirkinc.com](http://www.selkirkinc.com), or [www.mtlfab.com](http://www.mtlfab.com).

## VENTING TO EXISTING FIREPLACE

In some instances, people desire to convert an existing fireplace for stove use. Usually, safe connection to an existing masonry chimney requires more work than using a prefabricated chimney. The existing fireplace must be closed and sealed at the damper with high-temperature caulk, ceramic wool, or furnace cement. Prior to installation, clean and inspect the existing flue and smoke shelf. Installation should be designed so the system can be dismantled for periodic cleaning and inspection. Before conversion, make sure the existing chimney is structurally sound, the chimney incorporates a flue liner and make sure it is in good condition. (A flue liner consists of clay tile that protects the brickwork of a chimney. If a chimney does not have a liner, or it is damaged, have it relined by a professional. **DO NOT USE a chimney that is unlined or damaged!**) If you have any question regarding the condition of the chimney, consult a qualified licensed contractor, qualified engineer, competent mason, certified Chimney Sweep, or a knowledgeable inspector. Consult your insurance company if you cannot find a qualified expert.

**CAUTION: NOT ALL FIREPLACE CHIMNEYS ARE SUITABLE FOR CONVERSION TO ACCOMMODATE CONNECTION TO A WOOD STOVE. CHECK WITH A QUALIFIED EXPERT.**

Many prefabricated fireplaces are of the "zero-clearance fireplace" category. These consist of multi layered metal construction. They are designed with enough insulation and/or air cooling on the base, back and sides so they can be safely installed in direct contact with combustible floors and walls. Although many prefabricated fireplaces carry

*Continued on next page*



## CHIMNEY CONNECTIONS *continued ...*

endorsements from nationally recognized organizations for use as fireplaces, they have not been tested for connection to wood stove heaters. Connecting a stove to such a device will void the manufacturer's warranty.

Venting a stove directly into a fireplace does not meet code and should not be attempted. The stove warranty will be void with such an installation. Do not create a hazard in your home by connecting in this manner.

### FIREPLACE INSTALLATION

Directly connecting the stovepipe into the existing masonry chimney (figure 13 "Type A" Fireplace Conversion) of the fireplace is the only approved method of installation. This is a complicated and involved process and to insure safety should only be done by a qualified installer.

1. An entry hole must be cut through the masonry and tile liner with minimal damage to the liner. At least 8" of liner must remain below the entry position. When locating the stove and stovepipe, all minimum clearances must be observed from combustible surfaces including mantels, combustible trim work, ceilings and walls. Positioning the center of the stove pipe entry into the chimney 24" below the ceiling should insure proper clearance for a 6" stovepipe.
2. Install a metal or fire clay (5/8" minimum thickness) thimble. Make sure the thimble is flush with the inner surface of the chimney liner and does not protrude into the flue (see figure 8 on page 6).
3. Secure the thimble with refractory mortar. The thimble should be surrounded by 12" of solid unit masonry brickwork or 24" of stone.
4. Install the stovepipe into the thimble as far as possible without extending past the flue lining (see figures 8 & 9 on pages 6 & 7).
5. A small airspace (about 1/2") should remain between the stovepipe and thimble to allow for expansion of the pipe. Seal this airspace with high-temperature caulking or ceramic wool.
6. Secure and seal the damper in the closed position using high-temp caulking, ceramic wool, or furnace cement. Also check to see if the chimney has a cleanout. If it does, make sure it is closed and sealed as well. A leaky cleanout will greatly reduce draft efficiency.

If you have any questions regarding venting your stove, contact the manufacturer or contact the National Fire Protection Association (NFPA) and request a copy of the latest editions of NFPA Standard 211 and NFPA Standard 908. Their address is:

Battery March Park, Quincy, MA 02269.

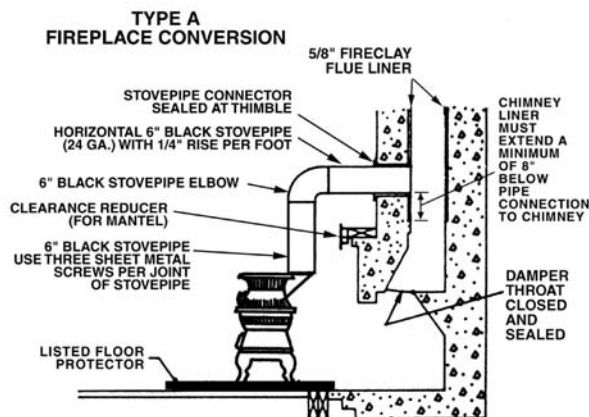
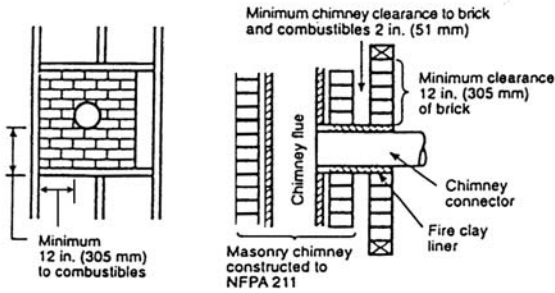

Fig. 13 - Fireplace Conversion

# CHIMNEY CONNECTOR SYSTEMS & CLEARANCES



## A. Brick Masonry

Minimum 3.5" / 89mm thick brick masonry all framed into combustible wall with a minimum of 12" / 305mm brick separation from clay liner to combustibles. The fireclay liner shall run from outer surface of brick wall to, but not beyond, the inner surface of chimney flue liner and shall be firmly cemented in place.

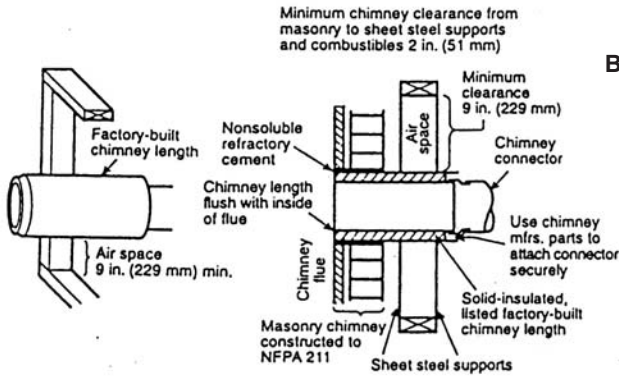

## B. Insulated Sleeve

Solid-insulated, listed factory-built chimney length of the same inside diameter as the chimney connector and having 1" / 25.4mm or more of insulation with a minimum 9" / 229mm air space between the outer wall of the chimney length and combustibles.

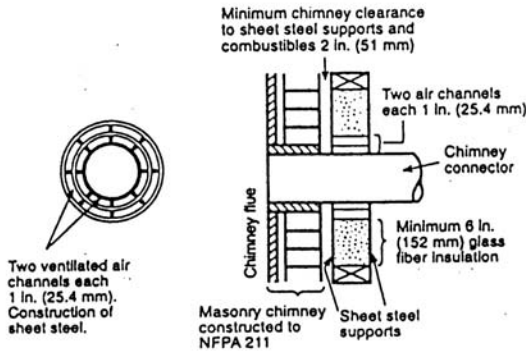

## C. Ventilated Thimble

Sheet steel chimney connector, minimum 24 gauge in thickness, with a ventilated thimble, minimum 24 gauge in thickness, having two 1" / 25.4mm air channels, separated from combustibles by a minimum of 6" / 152mm of glass fiber insulation. Opening shall be covered, and thimble supported with a sheet steel support, minimum 24 gauge in thickness.

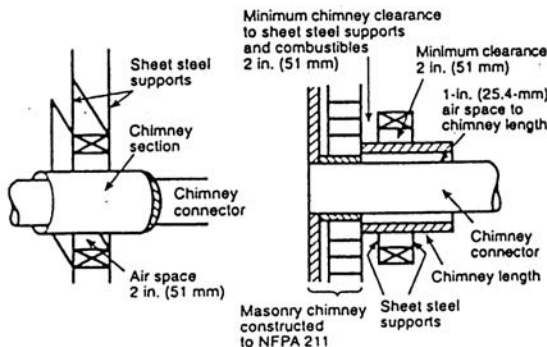

## D. Chimney Section Pass-through

Solid insulated, listed factory-built chimney length with an inside diameter 2" / 51mm larger than the chimney connector and having 1" / 25.4mm or more of insulation, serving as a pass-through for a single wall sheet steel chimney connector of minimum 24 gauge thickness, with a minimum 2" / 51mm air space between the outer wall of chimney section and combustibles. Minimum length of chimney section shall be 12" / 305mm chimney section spaced 1" / 25.4mm away from connector using sheet steel support plates on both ends of chimney section. Opening shall be covered, and chimney section supported on both sides with sheet steel support securely fastened to wall surfaces of minimum 24 gauge thickness. Fasteners used to secure chimney section shall not penetrate chimney flue liner.

# OPERATING INSTRUCTIONS

## CAUTION: HOUSE FIRE HAZARDS

- **GASSES EMITTED FROM FRESHLY ADDED COAL MUST BE BURNED OR THEY WILL ACCUMULATE AND EXPLODE. NEVER SMOTHER A FIRE WHEN ADDING FRESH COAL.**
- **NEVER USE MANUFACTURED “COAL BRICKS” MADE OF COAL DUST AND WAX-TYPE BINDER.**
- **DO NOT STORE WOOD OR COAL ON FLOOR PROTECTOR, UNDERNEATH STOVEPIPE OR ANYWHERE WITHIN MINIMUM CLEARANCES FROM COMBUSTIBLE SURFACES SPECIFIED FOR THIS STOVE. (36”)**
- **OVER FIRING MAY CAUSE A HOUSE FIRE. YOU ARE OVER FIRING IF THE STOVE OR CHIMNEY CONNECTOR GLOWS RED.**
- **BUILD FIRES ONLY ON INTEGRAL GRATE INCLUDED WITH THE STOVE.**

## WARNING: EXPLOSION HAZARD

- **NEVER USE CHEMICALS, GASOLINE, GASOLINE-TYPE LANTERN FUEL, KEROSENE, NAPHTHA, CHARCOAL LIGHTER FLUID, OR SIMILAR FLAMMABLE LIQUIDS TO START OR “FRESHEN-UP” A FIRE IN THE STOVE.**
- **KEEP ALL FLAMMABLE LIQUIDS, ESPECIALLY GASOLINE, OUT OF THE VICINITY OF THE STOVE — WHETHER IN USE OR IN STORAGE.**

## OPERATING SAFETY PRECAUTIONS

1. **STOVE IS HOT WHILE IN OPERATION. KEEP CHILDREN, CLOTHING, AND FURNITURE AWAY FROM HOT STOVE. CONTACT MAY CAUSE SKIN BURNS. DO NOT TOUCH THE STOVE AFTER FIRING UNTIL IT HAS COOLED.**
2. **NEVER OVER FIRE THIS STOVE BY BUILDING EXCESSIVELY HOT FIRES AS A HOUSE/BUILDING FIRE MAY RESULT. YOU ARE OVER FIRING THE STOVE IF STOVE OR STOVEPIPE BEGINS TO GLOW OR TURN RED.**
3. **NEVER BUILD EXTREMELY LARGE FIRES IN THIS TYPE OF STOVE AS DAMAGE TO THE STOVE OR SMOKE LEAKAGE MAY RESULT.**
4. **PROVIDE AIR INTO THE ROOM FOR PROPER COMBUSTION.**
5. **INSPECT STOVEPIPE EVERY 60 DAYS. REPLACE IMMEDIATELY IF STOVEPIPE IS RUSTING OR LEAKING SMOKE INTO THE ROOM.**

## For use with SOLID WOOD or COAL FUEL ONLY.

Hardwood, 10” to 14” should be air dried (seasoned), for a minimum of 6 months. Logs greater than 6” in diameter should be split. Wood should be stored in a dry, well ventilated area. The humidity content for usable firewood must be less than 20% of the weight of the log.

Attempts to use wet or unseasoned wood will cause:

- ignition problems
- rapid creosote build-up with possible chimney fire.
- incomplete combustion
- low heat yield

Chestnut, egg stove or nut-sized coal for residential furnaces or any of the specialty packaged fireplace coals (not wax-type “Coal Bricks”) can be used. Low ash content (2% to 6%) coal is recommended.

**NOTICE: USE SOLID WOOD OR COAL MATERIALS ONLY. FOR BEST RESULTS WHEN BURNING COAL, USE SOLID, BITUMINOUS COAL. NEVER USE MANUFACTURED COAL “BRICKS” MADE OF COAL DUST AND WAX-TYPE BINDER. STORE COAL IN DRY, WELL VENTILATED AREA. DO NOT BURN GARBAGE, CHARCOAL OR FLAMMABLE LIQUIDS SUCH AS GASOLINE, NAPHTHA OR ENGINE OIL.**

## LIGHTING

1. Open flue draft damper fully to provide maximum draft.
2. Remove lid(s) and place several wads of crushed paper in the firebox.
3. Lay small stacks of kindling on the paper to start the fire.
4. Light the paper and kindling and replace the lid(s). Make sure they are seated properly. Keep ash door closed when stove is in use.
5. Add fuel after fire is burning briskly. Use care not to smother the kindling fire when adding fuel. Replace the lid(s) and make sure they are seated firmly.
6. Adjust the draft damper and spin draft control. The more closed the spin draft is set, the lower and slower the fire will burn. The more open, the faster and hotter the fire will burn. Do not overfire the stove.
7. NEVER build extremely large fires in this type of stove as damage to the stove or smoking may result. If you have too much draft, then regulate the draft with the 6” stove pipe damper.
8. **DO NOT TOUCH – SEVERE BURNS MAY RESULT!**

*continued on next page*

## OPERATING INSTRUCTIONS *continued ...*

After firing DO NOT TOUCH STOVE until it has cooled.

9. Replace lid(s) and make sure they are seated properly..
10. This is a cast iron stove. It does **NOT** have welded seams. From time to time you may need to "refill and/or replace the stove cement/mortar along the seams.

### ADDING FUEL

Add small amounts of fuel each hour or so instead of piling large quantities of fuel at one time. This will insure a more complete combustion process and less buildup of tars, soot, or creosote will occur in the chimney.

1. Always open flue draft damper before removing the lids.
2. When adding fuel be careful not to smother the fire.
3. Replace lids and seat securely.
4. Adjust the flue damper and spin draft controls.
5. Empty ashes regularly. Do not allow ashes to pile up higher than the top of the hearth (see Safety Instructions #14 page 2). If ashes build up to the grate, burnout will occur.
6. Properly dispose of hot ashes (see Safety Instructions, item #14 on page 2.)
7. Do not over fire the stove.

**CAUTION: DO NOT OVER FIRE APPLIANCE. TOO MUCH FUEL OR BURNING PROHIBITED MATERIALS SUCH AS TRASH OR FLAMMABLE LIQUIDS MAY CAUSE OVER FIRING. YOU ARE OVER FIRING IF ANY PART OF THE STOVE OR THE CHIMNEY CONNECTORS GLOWS RED. IMMEDIATELY CLOSE THE DOOR, SPIN DRAFT AND FLUE DAMPER TO REDUCE THE AIR SUPPLY TO THE FIRE. THIS WILL SLOW DOWN THE FIRE.**

**CAUTION: SLOW BURNING FIRES AND EXTENDED USE MAY CAUSE EXCESSIVE CREOSOTE BUILDUP. IGNITION OF CREOSOTE BUILDUP OR OVER FIRING MAY CAUSE A CHIMNEY FIRE. CHIMNEY FIRES BURN EXTREMELY HOT AND MAY IGNITE SURROUNDING MATERIALS. IN CASE OF A CHIMNEY FIRE LEAVE THE BUILDING AND CALL THE FIRE DEPARTMENT FROM A SAFE LOCATION.**

**ASH DISPOSAL** – While in use, empty ash pan regularly. Too much ash accumulation can restrict airflow to the fire and damage the grate. Dispose of ashes properly. (See Safety Instructions #14, page 2.)

**CHIMNEY DRAFT** – Draft is a function of the chimney, not the stove — do not expect the stove to draw. Smoke spillage into the house or excessive buildup of condensation or creosote in the chimney are warnings that the chimney is NOT functioning properly. Correct the problem before using the stove. Following are some possible causes for improper draft.

1. The connector stovepipe may be pushed into the chimney too far, stopping the draft.
2. If the chimney temperature is too cool, water will condense in the chimney and run back into the stove. Creosote formation will be rapid and may block the chimney. Operate the stove at a fire level high enough to keep the chimney warm to prevent condensation from forming.
3. If the fire burns well but sometimes creates excess smoke or burns slowly, it may be caused by the chimney top being lower than another part of the house or a nearby tree. The wind blowing over a house or tree, falls on top of the chimney like water over a dam, beating down the smoke. The top of the chimney should be at least three (3) feet above the roof and be at least two (2) feet higher than any point of the roof within ten (10) feet. (See also draft on page 7).

### CREOSOTE – Formation and Need for Removal

**CAUTION: RISK OF FIRE** When wood fuel is burned slowly, it produces tar and other organic vapors, which combine with expelled moisture to form creosote. The organic vapors condense in the relatively cool chimney flue of a slow-burning fire. As a result, creosote residue accumulates on the flue lining. When ignited this creosote buildup makes an extremely hot fire.

The chimney connector and chimney should be inspected at least once every two months during the heating season to determine if a creosote buildup has occurred.

If buildup has accumulated (3mm or more) it should be removed to reduce the risk of a chimney fire.

Failure to remove creosote may result in ignition and may cause a house/building fire. Creosote may be removed using a chimney brush or other commonly available materials from your local hardware retailer.

### Preventing Creosote Buildup

1. Creosote will inevitably form in your chimney and connector pipe. Following these steps will help reduce the rate of build up.



## MAINTENANCE & SERVICE HINTS

2. When burning wood, use hardwood rather than softwood. Burn only seasoned (<20% humidity by weight) wood. Do not mix green wood with seasoned wood. Wood that hisses, sizzles, and blackens prior to igniting should be considered too green. Green or wet wood rapidly builds up creosote and reduces heat output by up to 25%.
2. **Avoid smothering the fire with too much fuel. Too much fuel loaded at one time will create heavy, volatile gas which can coat the chimney with creosote-forming tar.**
3. Burn the stove with the spin draft control wide open for 10-15 minutes every time fresh fuel is loaded into the stove. Do not load more than ¼ to ½ of the fuel capacity at one time. Loading too much fuel at once will cause excessive smoke which contains creosote. Mature fires or coals produce very little creosote-producing smoke.
4. Burn with the spin draft control open for several minutes at numerous intervals throughout the day, being careful not to over fire the unit. Following this process will help to warm the chimney and reduce the amount of creosote forming condensation within the chimney.
5. Establish a routine for the handling of fuel, firing, and operating the stove. Check daily for creosote build up until experience shows how often you need to clean for safe operation. Be aware that the hotter the fire, the less creosote is deposited and weekly cleanings may be necessary in mild weather even though monthly cleanings may be enough in the colder months.

**WARNING: IN CASE OF CHIMNEY FIRE  
(1) CLOSE AIR INLET CONTROL AND FLUE PIPE DAMPER. (2) GET OUT OF THE HOUSE  
(3) CALL THE FIRE DEPARTMENT.**

### SOOT - Formation & Need for Removal

**CAUTION: RISK OF FIRE.** When coal is burned, the products of combustion combine with moisture to form a soot residue which accumulates in the flue lining. When ignited, this soot makes an extremely hot fire.

The chimney connector and chimney should be inspected at least once every two months during the heating season to determine if a soot buildup has occurred.

If soot has accumulated, it should be removed to reduce the risk of a chimney fire.

Additionally, coal combustion by-products like sulphur dioxide, sulphur trioxide and others can corrode

stainless steel and masonry chimneys. It is important to inspect and clean chimney on a regular schedule.

**CHIMNEY INSPECTIONS** – The chimney connector and chimney should be inspected **at the beginning** of and **at least twice a month during** the heating season to determine if a creosote or soot buildup has occurred.

Chimney fires burn very hot. If any part of the stove, chimney or chimney connector should glow red, reduce the fire by closing the damper and spin draft control and immediately call the fire department.

**CAUTION: A CHIMNEY FIRE MAY CAUSE IGNITION OF WALL STUDS OR RAFTERS WHICH WERE ASSUMED TO BE A SAFE DISTANCE FROM THE CHIMNEY. IF A CHIMNEY FIRE HAS OCCURRED, HAVE YOUR CHIMNEY INSPECTED BY A QUALIFIED EXPERT BEFORE USING AGAIN.**

A fire in the stove may be smothered by pouring a large quantity of coarse salt, baking soda, or cool ashes on top of the fire.

**STOVE JOINTS – Required Tune-up.** This stove is manufactured with cast iron components. **IT DOES NOT HAVE WELDED SEAMS.** Periodic “tune up” may be required by refilling and/or replacing the cement/joint mortar along the seams where the cast iron components meet.



# PARTS LIST – SR57E RANCHER WOOD & COAL RANGE

When ordering missing or replacement parts, always give the **Model Number** of the stove, **Part Number**, and **Part Description**. Use the illustrations and part lists provided to identify parts. Contact us at **616-396-1911** to order parts.

Part No.	Description	Qty.
1	Cook Lid .....	4
2	Collar Top.....	1
3	Top Plate.....	1
4	Removable Plate .....	2
5	Lid Support.....	1
6	Burn Chamber .....	1
7	Lower Chamber .....	1
8	Shaker Door .....	1
9	Base .....	1
10	Ash Door.....	1
11	Spin Draft.....	1
12	Spring Handle.....	1
13	Grate .....	1
14	Ash Pan .....	1
15	Legs .....	4
16	Lid Lifter.....	1
17	Hardware Pack .....	1
18	Draft Damper .....	1

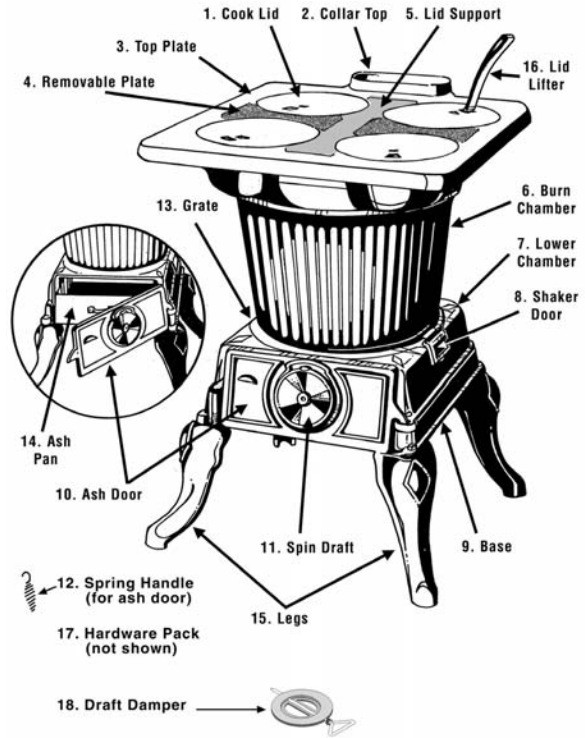

# FLOOR PROTECTOR MATERIAL CALCULATIONS

---

This stove has been tested for and must be installed on a floor protector with the proper Thermal Resistance or R-value as stated in step 1 of the installation instructions under “Locating Stove” section of this manual. If the floor protector materials listed in the instructions are not available, materials with an equivalent R-value may be substituted.

Alternate materials may be rated with C-factor (Thermal Conductance) or k-factor (Thermal Conductivity) ratings which must be converted to R-value to determine if the alternate material meets the tested requirements. The following instructions provide the proper information and formulas for conversion to R-value.

To determine if alternate materials are acceptable follow this sequence.

1. Convert material specifications to R-value:
  - a. R-value given — no conversion necessary
  - b. K-factor is given with a required thickness (T) in inches:  

$$R = 1/k \times T$$
  - c. C-factor is given:  $R = 1/C$
2. Determine the R-value of proposed alternate floor protector:
  - a. Use formulas in step 1 above to calculate R-value of proposed material(s).
  - b. For multiple layers, add R-values of each layer to determine overall R-value.
3. If the overall R-value of the floor protector system is equal to or greater than the floor protector specifications given, the alternate is acceptable.

Definitions:

$$\text{Thermal conductance}(C) = \frac{\text{BTU}}{(\text{hr})(\text{ft}^2)(\text{°F})} = \frac{W}{(\text{m}^2)(\text{°K})}$$

$$\text{Thermal conductivity } (k) = \frac{(\text{Btu})(\text{inch})}{(\text{hr})(\text{ft}^2)(\text{°F})} = \frac{W}{(\text{m})(\text{°K})} = \frac{\text{Btu}}{(\text{hr})(\text{ft})(\text{°F})}$$

$$\text{Thermal resistance } (R) = \frac{(\text{ft}^2)(\text{hr})(\text{°F})}{\text{Btu}} = \frac{(\text{m}^2)(\text{°K})}{W}$$

Example:

The specs of floor protector material should be 3/4-inch thick material with a k-factor of 0.84. The proposed alternative material is 4” brick with a C-factor of 1.25 over 1/8-inch mineral board with a k-factor of 0.29.

Step 1: Convert specs to R-value.

$$R = 1/k \times T = 1/0.84 \times 0.75 = 0.893 \quad \text{System must have a R-value of } 0.893 = R_{\text{specs}}$$

Step 2: Calculate R-value of individual components

$$4'' \text{ Brick with C-factor} = 1.25. \quad R = 1/C = 1/1.25 = 0.80 = R_{\text{brick}}$$

$$1/8\text{-inch } (0.125'') \text{ mineral board with k-factor} = 0.29. \quad R = 1/0.29 \times 0.125 = 0.431 = R_{\text{min.brd.}}$$

Step 3: Add R-values of components to get total R-value of system

$$R_{\text{brick}} + R_{\text{min.brd}} = 0.80 + 0.431 = 1.231 = R_{\text{system}}$$

Step 4: Compare Rsystem to Rspecs

Rsystem = 1.231 is larger than Rspecs of 0.893. System R-value exceeds the required specifications and therefore is an acceptable alternative.

---

This Vogelzang heating appliance is safe when installed properly and will provide you with years of service. However, always exercise good judgement when you are using this stove. You are dealing with FIRE! Fire is inherently dangerous and must be treated with respect. Stay warm and in good health!

Respectfully yours,

*Steve Vogelzang*

Proprietor

**DO NOT INSTALL THIS STOVE IN A  
MOBILE HOME, MANUFACTURED HOME,  
TRAILER OR TENT — NO EXCEPTIONS!**

**COMPANY TESTIMONY:**

**“FOR GOD SO LOVED THE WORLD THAT HE GAVE HIS ONLY BEGOTTEN SON, THAT WHOEVER BELIEVES IN HIM SHALL NOT PERISH BUT HAVE ETERNAL LIFE”**

**JOHN 3:16**

**MADE IN CHINA**

---

**VOGELZANG**

*International* CORPORATION



Vogelzang International Corporation  
400 West 17th Street  
Holland, Michigan 49423  
[www.vogelzang.com](http://www.vogelzang.com)  
Phone: 1-616-396-1911  
Fax: 1-616-396-1971