



**VF55**

MULTI-FUEL PELLET STOVE

**VISTAFLAME**   
HEARTH PRODUCTS

# WARM UP TO A VISTAFLAME



## Specifications

VF55

Heat Output*	55,000 BTU
Heating Area	2,500 ft <sup>2</sup>
Efficiency*	78%
EPA Emissions	2 g per hour
Hopper Capacity	80 lbs
Weight	300 lbs
Power (normal use / start up)	300/600 watts
Variable Fan Speed	300 cfm

\*Efficiency, emissions and area heated will vary according to fuel type, venting and location

## Clearance to Combustibles

Clearance from Side wall to side of unit	12"
Clearance between rear wall to back of unit	3"
Clearance from the top of the unit	48"
Clearance from corner of unit to wall	3"

Please see owner's manual for more information

## VF55 Features

- **Tri-mode Operating System** – Manual, Hi/Lo, Auto Off.
- **Capacitor-Driven Fan Motors** – For quiet operation.
- **Multi-Fuel Pellet Engine** – Burns premium pellets, regular pellets, and even alternate fuels.
- **Air Wash System** – For cleaner glass.
- **Extra Large Ash Pan** – Less frequent cleanings
- **Built In Floor Protection** – No hearth pad required.
- **Individually Welded Heat Exchanger Tubes** – Added durability and strength.

## VF55 Options

- **Wireless Digital Thermostat or Remote Control** – An optional wireless digital Wall Thermostat and remote control are available for the VF55.
- **Fluted Cast Iron Firebox Liner** – Detailed durable and decorative with heavy-gauge construction..
- **Ceramic Log Set** – Finely crafted, realistic looking ceramic log set gives a new dimension to the pellet fire.
- **Hopper Extension kit** – doubles the size of the hopper increasing the pellet capacity to 160 lbs.

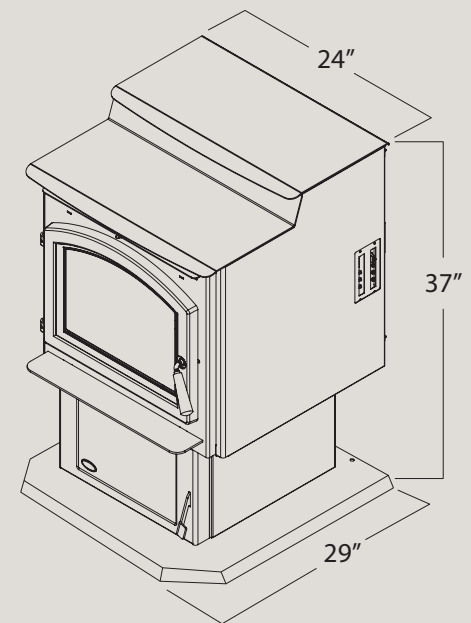

Manufactured by Sherwood Industries Ltd  
Victoria, BC, Canada ▪ [vistaflame.ca](http://vistaflame.ca)

Printed in Canada, January 2013