



VF170

FREESTANDING PELLET STOVE

VISTAFLAME 
HEARTH PRODUCTS

WARM UP TO A VISTAFLAME



Specifications

VF170

| | |
|-------------------------------|-----------------------|
| Heat Output* | 70,000 BTU |
| Heating Area | 2,700 ft ² |
| Efficiency* | 86% |
| EPA Emissions | 2.3 g per hour |
| Hopper Capacity | 130 lbs |
| Weight | 325 lbs |
| Power (normal use / start up) | 300/600 watts |
| Variable Fan Speed | 455 cfm |

* Efficiency, emissions and area heated will vary according to fuel type, venting and location

Clearance to Combustibles

| | |
|---|-----|
| Minimum distance to the sides of the unit | 12" |
| Minimum non-combustible surface behind the unit | 4" |
| Min. non-combustible surface from the top of the unit | 48" |
| Minimum non-combustible surface to corner of unit | 4" |

Please see owner's manual for more information

VF170 Features

- **Tri-mode Operating System** – Manual, Hi/Lo, Auto Off.
- **Heat Exchanger** – Extra large 1320 in² heat exchanger that is self-cleaning.
- **Extra Large Ash Pan** – Large dual-chambered ash pan removes easily and requires less frequent cleaning.
- **Built In Floor Protection** – No hearth pad required.
- **Hopper Capacity** – 130 lbs hopper capacity allows you to operate for longer periods without having to refill.
- **Leveling Legs** – convenient for uneven surfaces.
- **High Performance Fan** – Our most powerful room fan at 455 cfm, excellent for heating large areas.

VF170 Options

- **Wireless Digital Thermostat or Remote Control** – An optional wireless digital Wall Thermostat and remote control are available for the VF170.

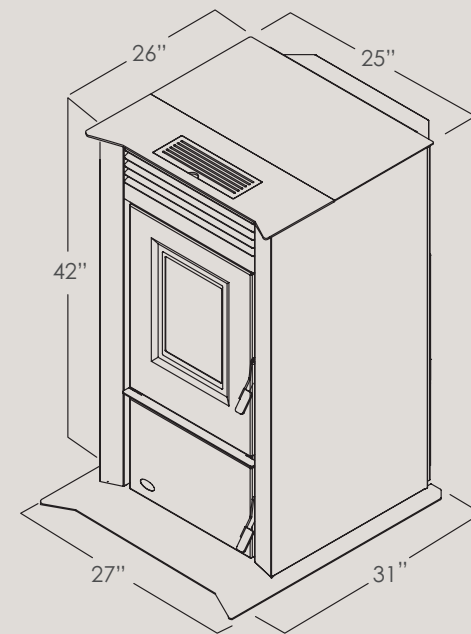

Manufactured by Sherwood Industries Ltd
 Victoria, BC, Canada ▪ vistaflame.ca
 Printed in Canada, January 2013