



**VF100**

FREESTANDING PELLET STOVE

**VISTAFLAME**   
HEARTH PRODUCTS

# WARM UP TO A VISTAFLAME



## Specifications

### VF100 FS & FPI

Maximum Heat Output*	45,000 BTU
Minimum Heat Output*	10,000 BTU
Heating Area	2,200 ft <sup>2</sup>
Efficiency*	82%
Hopper Capacity	55 lbs
Glass Size	185 in <sup>2</sup>
Power (normal use / start up)	250/520 watts
Variable Fan Speed	160 cfm

\* Efficiency, emissions and area heated will vary according to fuel type, venting and location

## VF100 Features

- **Large heat exchanger**
- **Easy access hopper**
- **Steel brick firebox liner**
- **Large ash pan**
- **Standard ignitor**
- **Hidden door handle**
- **Fireplace surround (FPI only)**
- **Mobile home approved**
- **Automatic controls**

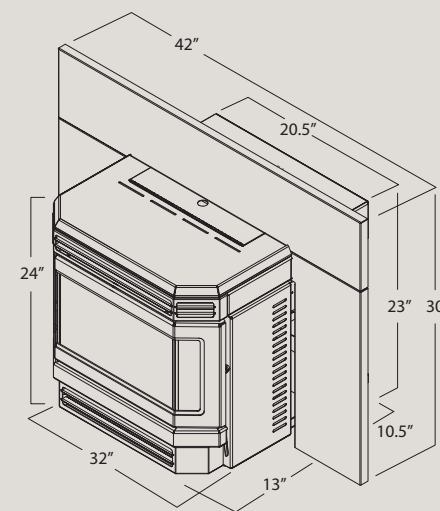
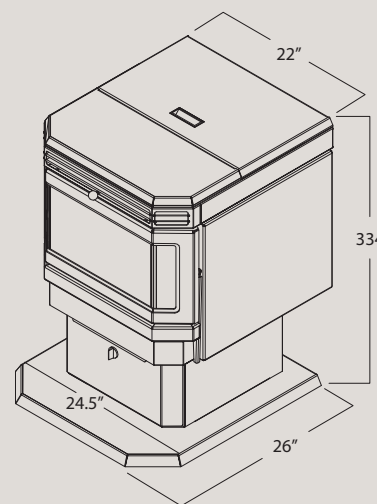

More detailed measurements available in product manual

## Clearance to Combustibles

Side wall to unit — FS & FPI	6"	8"
Rear wall to back of unit — FS	1"	—
Adjacent wall to corner — FS	1"	—
Floor Protection in front — FS & FPI	6"	6"
Top of unit to mantle — FPI	—	8"

More detailed clearances available in product manual..

## VF100 Options

- **Wireless Digital Thermostat or Remote Control** – An optional wireless digital Wall Thermostat and remote control are available for the VF100.
- **Trim Variety** – Painted black, and brushed nickel.
- **Oversized Surround** – FPI model only.



Manufactured by Sherwood Industries Ltd  
Victoria, BC, Canada ▪ [vistaflame.ca](http://vistaflame.ca)  
Printed in Canada, January 2013