

Owner's Instruction and Operation Manual

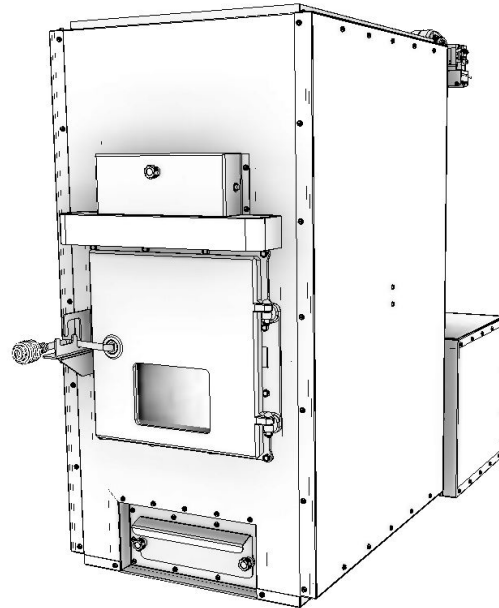

Model Number:
HB1520



Wood Only Central Furnace

Certified to UL-391-2006 (R2019), Certified to: CSA B366.1-11 (R2020), and CSA B415.1:22

* All Pictures In This Manual Are For Illustrative Purposes Only. Actual Product May Vary.

853966D- 0406M

Save These Instructions In A Safe Place For Future Reference.



SAFETY NOTICE: If this unit is not properly installed, a fire may result. For your safety, follow the installation instructions. Never use make-shift compromises during the installation of this unit. Contact local building or fire officials about permits, restrictions and installation requirements in your area.



CAUTION! Please read this entire manual before you install or use this unit. Failure to follow instructions may result in property damage, bodily injury, or even death. Improper Installation Will Void Your Warranty!

U.S. Environmental Protection Agency

Certified to comply with 2020 particulate emission standards

⚠️ CALIFORNIA PROPOSITION 65 WARNING:

This product can expose you to chemicals including carbon monoxide, which is known to the State of California to cause cancer, birth defects, and/or other reproductive harm. For more information, go to www.P65warnings.ca.gov

THIS MANUAL IS SUBJECT TO CHANGE WITHOUT NOTICE.

This manual describes the installation and operation of the Hotblast, HB1520 wood furnace. This furnace meets the 2020 U.S. Environmental Protection Agency’s emission limits for wood furnaces. Under specific EPA test conditions this furnace has been shown to deliver heat at a rate of 15,997 – 53,042 BTU/hr. This furnace achieved a particulate emissions rate of 0.13 lb/mmBtu when tested to method CSA B415.1-10 (*and an overall efficiency of 70%). The maximum overall heat output of this furnace was tested to be 65,258 Btu/hr.

Combustible:	Wood
Flue Pipe Diameter:	6” (153cm)
Flue Pipe Type: (Standard, Single Wall, or Double Wall):	Black or Blued Steel 2100°F (650°C) Class “A”
Minimum Chimney Height:	12 ft (3.65 m)
Maximum Log Length:	23” (585 mm)
Electrical:	120 Volts, 60 Hz, 6.0 Amps
Dimensions	
Assembled Height x Width x Depth:	45” (1143 mm) x 25-3/8” (645 mm) x 54-3/4” (1391 mm)
Combustion Chamber: Width x Depth:	13.75” (350 mm) x 24” (610 mm)
Volume: Cubic Feet:	3.95 Cu Ft.
Door Opening: Width x Height:	14” (356 mm) x 13.89” (353 mm)

CAUTIONS:

- **HOT WHILE IN OPERATION. KEEP CHILDREN, CLOTHING AND FURNITURE AWAY. CONTACT MAY CAUSE SKIN BURNS.**
- **DO NOT USE CHEMICALS OR FLUIDS TO IGNITE THE FIRE.**
- **DO NOT LEAVE THE STOVE UNATTENDED WHEN THE DOOR IS SLIGHTLY OPENED.**
- **DO NOT BURN GARBAGE, FLAMMABLE FLUID SUCH AS GASOLINE, NAPHTHA OR MOTOR OIL.**
- **DO NOT CONNECT TO ANY AIR DISTRIBUTION DUCT OR SYSTEM.**
- **ALWAYS CLOSE THE DOOR AFTER THE IGNITION.**
- **YOUR CHIMNEY MUST BE INSPECTED PRIOR TO THE INSTALLATION OF YOUR NEW WOOD STOVE. IN ADDITION, YOU SHOULD HAVE YOUR CHIMNEY INSPECTED FOR CREOSOTE DEPOSTS MONTHLY DURING THE HEATING SEASON AND ANNUALLY INSPECTED AND CLEANED.**



Note: Register your product online at www.usstove.com or download the free app today. This app is available only on the App Store for iPhone and iPad. Search US Stove. Save your receipt with your records for any claims.

For Customer Service, please call:
1-800-750-2723 Ext 5050 or;
Text to 423-301-5624 or;
Email us at:
customerservice@usstove.com

INSTALLATION CHECKLIST



Your Wood Stove should be installed by a qualified installer only. An NFI qualified Installer can be found at;
www.nficertified.org/public/find-an-nfi-pro/

CUSTOMER SERVICE

1-800-750-2723 ext 5050
Text to 423-301-5624
Email to: Customerservice@usstove.com

COMMISSIONING CHECKLIST

This checklist is to be completed in full by the qualified person who installs this unit. Keep this page for future reference. Failure to install and commission according to the manufacturer's instructions and complete this checklist will invalidate the warranty.

Please Print

Customer Name:	Telephone Number:
Address:	
Model:	
Serial Number:	
Installation Company Name:	Phone Number:
Installation Technician's Name:	License Number:

DESCRIPTION OF WORK

Location of installed appliance: _____

Chimney System: New Chimney System Yes No If yes, Brand _____

If no, Date of inspection of the existing chimney system: _____

COMMISSIONING

- Confirm Hearth Pad Installation as per Installation Instructions.....
- Confirm proper placement of internal parts.....
- Check soundness of door gasket and door seals
- Confirm clearances to combustibles as per installation instructions in this manual
- Check the operations of the air controls.....
- Confirm all flue pipe and chimney system are secure and sealed.....
- Confirm the stove properly drafts when fired.....
- Check to ensure a CO alarm is installed as per local building codes and is functional.....
- Explain the safe operation, proper fuel usage, cleaning and routine maintenance requirements.....

Declaration of Completion: As the qualified person responsible for the work described above, I confirm that the appliance as associated work has been installed as per manufacturer's instructions and following any applicable building and installation codes.

Signed: _____ Print Name: _____ Date: _____

Home Owner: RETAIN THIS INFORMATION FOR FUTURE REFERENCE

FOR CUSTOMER SERVICE CALL: 800-750-2723 EXT 5050

TOOLS AND MATERIALS

The following is a list of tools and materials needed to install your furnace.

- Safety glasses and gloves
- Various Hand Tools for component assembly. (Power tools preferably)
- All Chimney and Chimney Connector materials required for your particular installation.
- Electrical wiring tools and supplies
- All materials needed for Ductwork Installation (Supply and return air) (Return Air Box is supplied with the unit)

UNPACKING

1. Remove all packaging from the furnace.
2. Remove the supplied parts from the furnace.

FIREBRICK CONFIGURATION

Inspect for any damage. Ensure that the bricks and ash plug are positioned correctly and not broken (see illustration for proper brick arrangement). NOTE: The firebricks are silicone into place to prevent damage from shipping. Attempting to remove the firebricks before operation could result in damage.

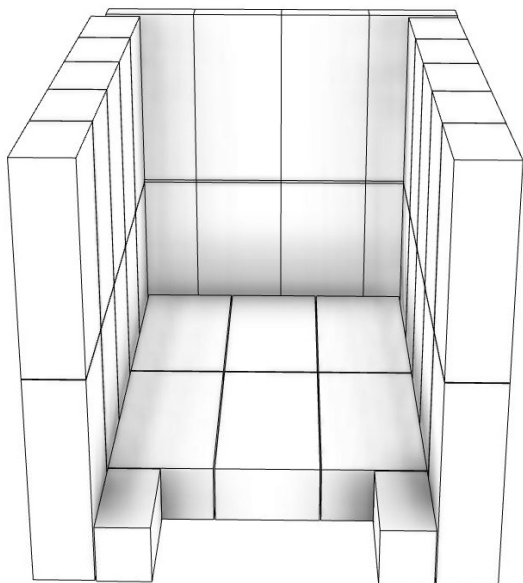

CERAMIC FIBER BOARD CONFIGURATION

Inspect for any damage. Ensure the fiber board is positioned correctly and not broken (see illustration for proper fiber board arrangement). NOTE: The ceramic fiber boards are silicone into place to prevent damage from shipping. Attempting to remove the ceramic fiber board before operation could result in damage.

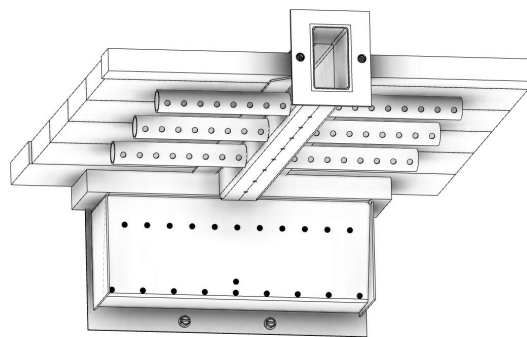

ASSEMBLY OF FURNACE

Your furnace requires the following items to be assembled or installed by the service person:

- Smoke Curtain
- Feed Door Handle & Latch
- Front Cover/Hood
- Distribution Blowers With Gaskets
- Junction Box Bracket
- Junction Box and Fan Center
- Draft Blower
- Honeywell Probe
- Filter Box
- Electrical Connections

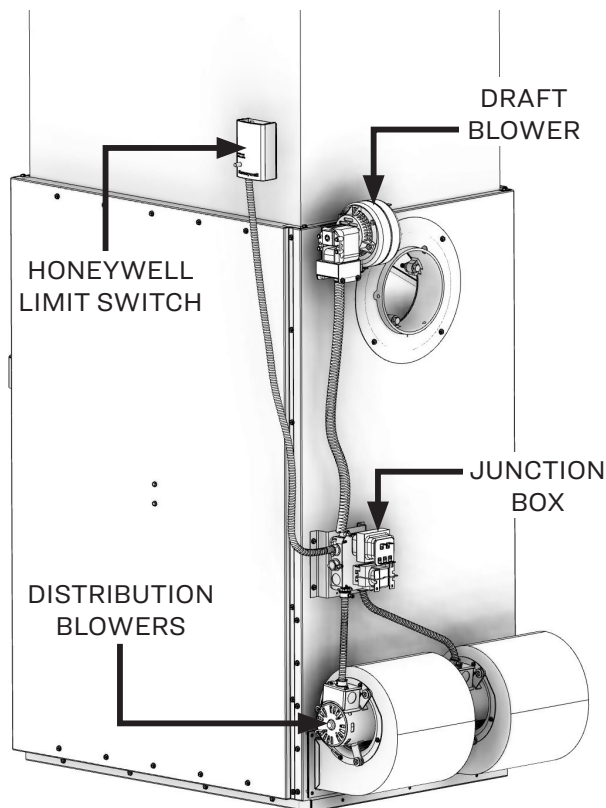

SMOKE CURTAIN

Using two (2) 1/4-20 x 1-1/4" Carriage bolts, two (2) smoke curtain clips, and two (2) nuts, attach the smoke curtain in place above the fuel feed door as shown. After installation, the smoke curtain should swing freely back into the furnace.

OUTSIDE VIEW OF THE UNIT

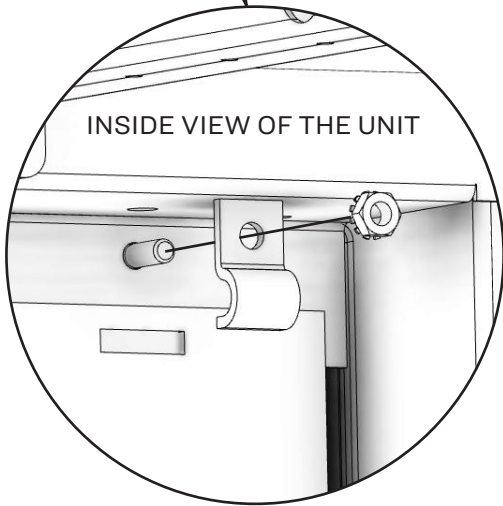
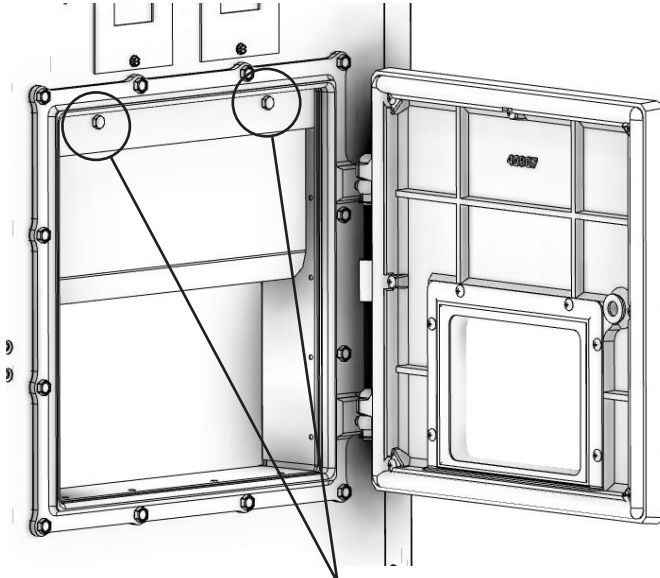

INSIDE VIEW OF THE UNIT

FEED DOOR HANDLE & LATCH

Use the included one (1) nut and one (1) washer to secure the handle to the stove as shown. Note: Adjust the handle as needed to ensure a proper seal.

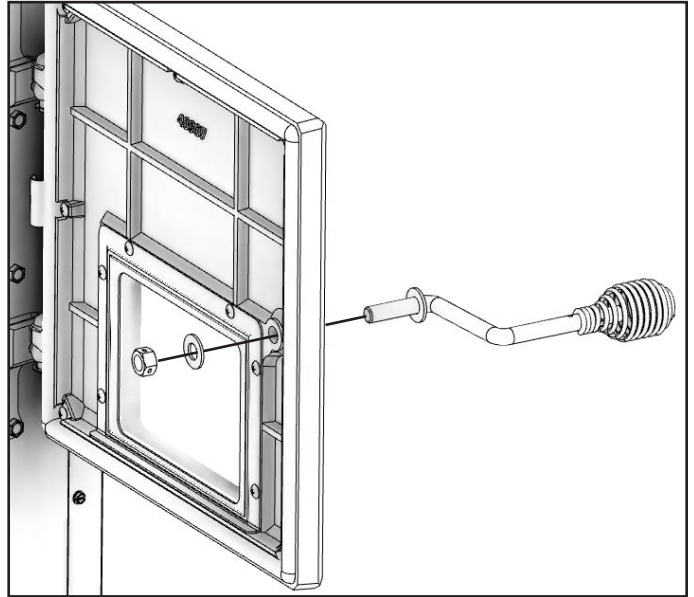

Use two (2) 1/4-20 x 3/4 bolts and two (2) washers to secure the latch assembly to the unit.

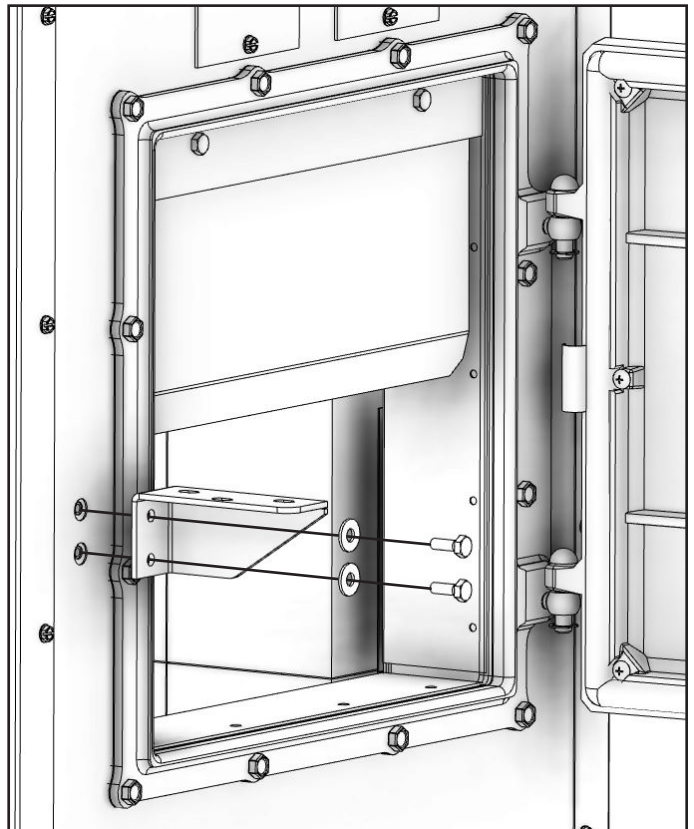

Use three (3) 1/4-20 x 3/4 bolts, three (3) washers, and three (3) 1/4-20 kep nuts to secure the latch top to the latch bottom.

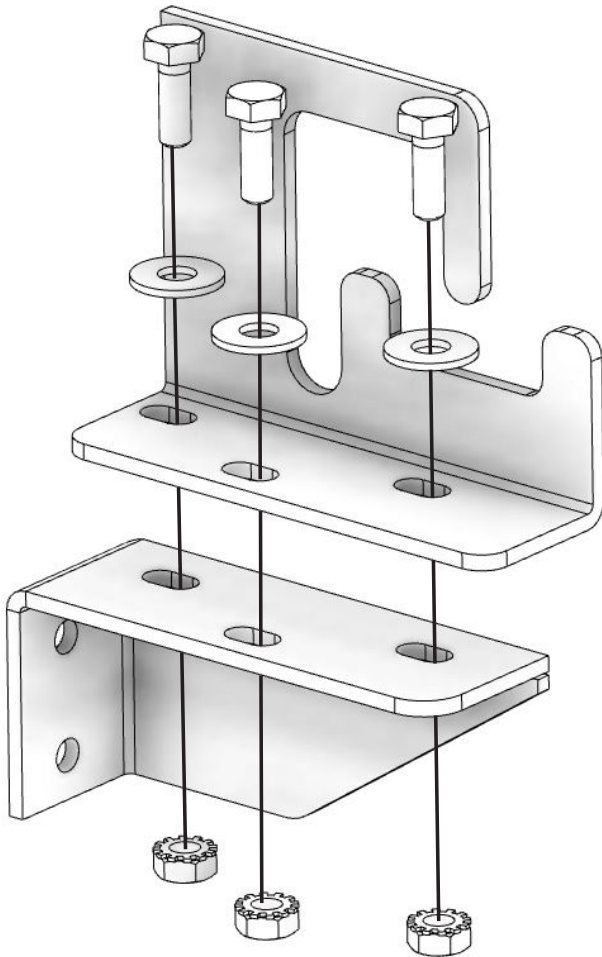

FRONT COVER/HOOD

Use the four (4) provided #10A x 1/2 screws to secure the front cover hood to the unit as shown.

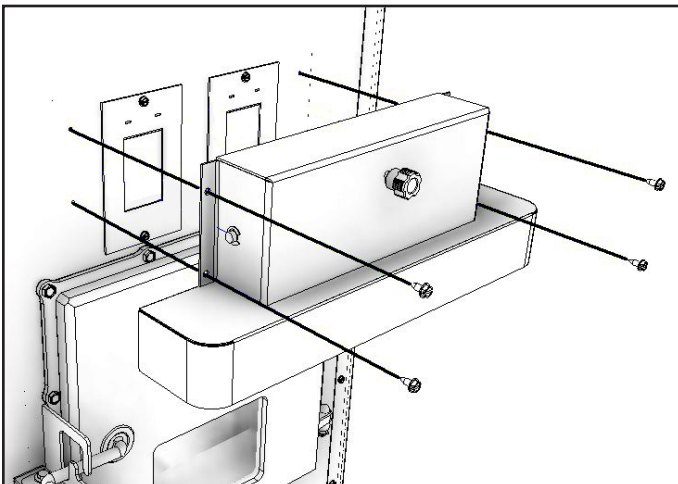

DISTRIBUTION BLOWERS WITH GASKETS

Secure the two blowers and gaskets to the unit using the eight (8) provided 1/4-20 x 3/4 bolts.

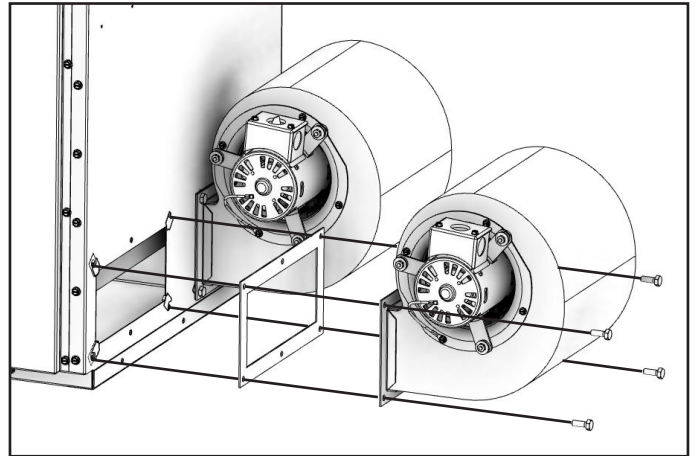

JUNCTION BOX BRACKET

Secure the junction box bracket to the unit using the four (4) provided #10A x 1/2 screws.

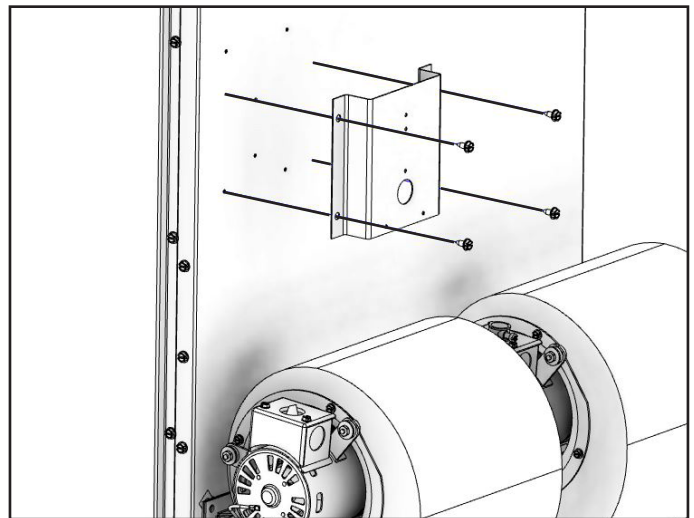

JUNCTION BOX & FAN CENTER

Secure the junction box to the junction box bracket using the two (2) provided #10A x 1/2 screws as shown.

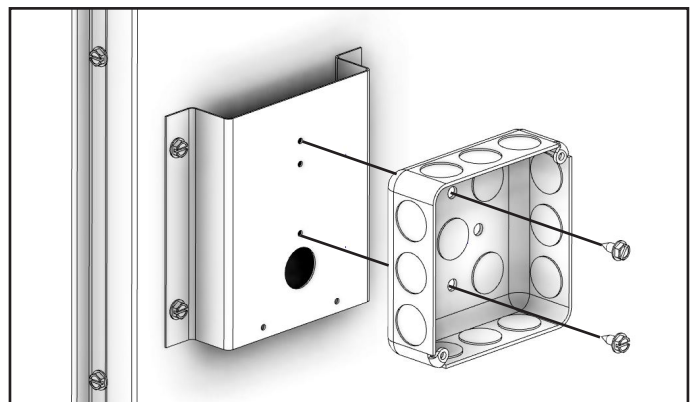

ASSEMBLY INSTRUCTIONS

Secure the fan center to the junction box using the two (2) provided screws as shown.

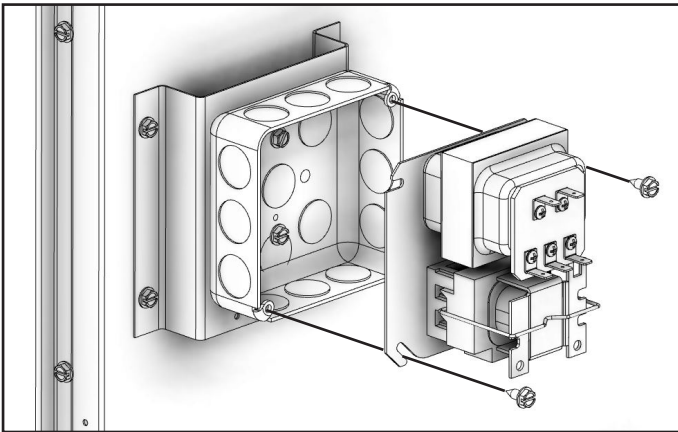

DRAFT BLOWER

Secure the draft blower to the back upper left-hand side of the unit using the four (4) provided 10-24 kep nuts.

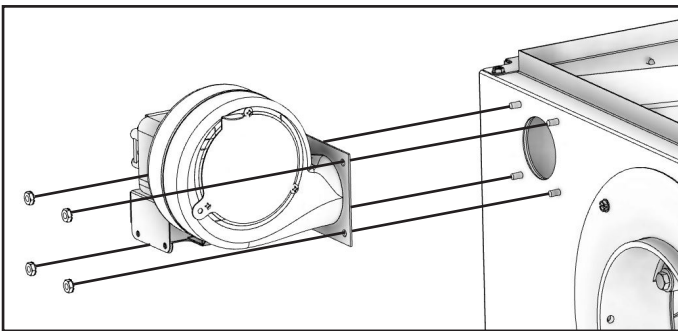

HONEYWELL PROBE

Install the Honeywell probe into the ductwork above the unit. NOTE: The conduit is supplied at a predetermined length of approximately 3 feet

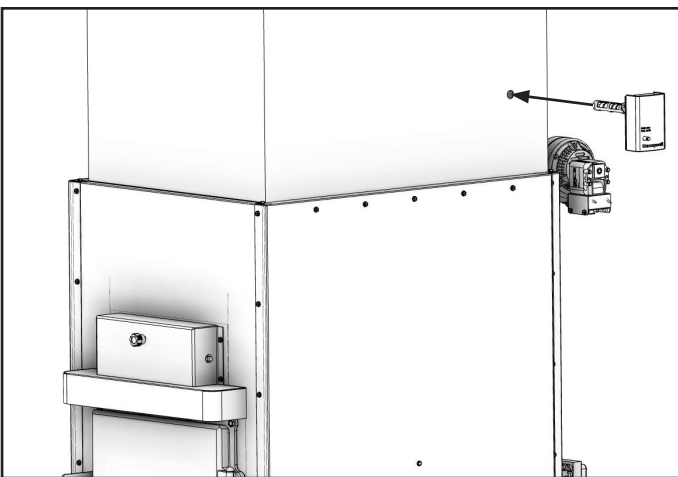

FILTER BOX

The filter box is made up of 4 parts, plus all hardware necessary for assembly.

Assemble the filter box sides, top, and bottom using twenty (20) #10 A x 1/2 HX screws.

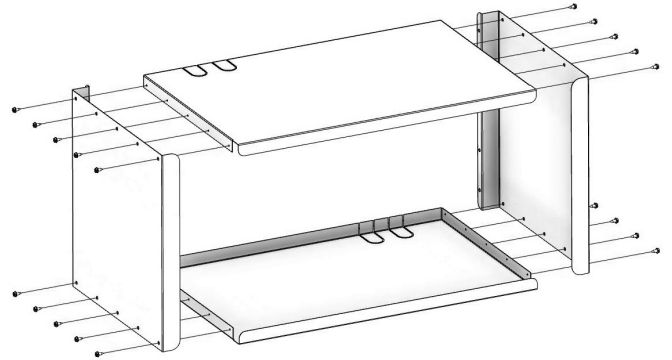

If your BX Cables will not match up to the previously matched arrangement on the top, carefully measure and custom notch to accommodate your particular arrangement of BX Cables. There are several different configurations.

Secure the filter box to the unit using a total of ten (10) #10 A x 1/2 HX screws, five (5) on each side.

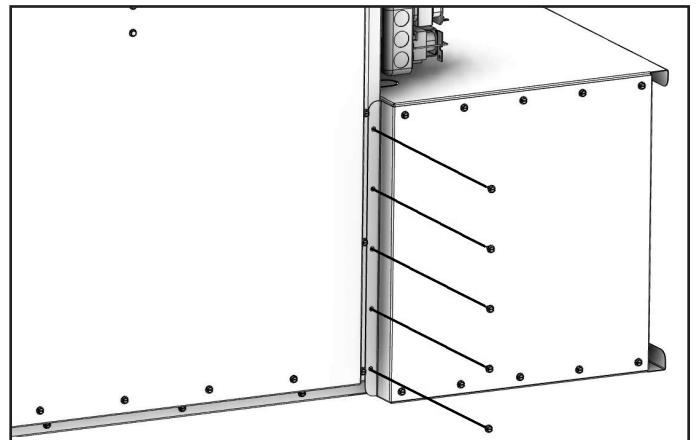
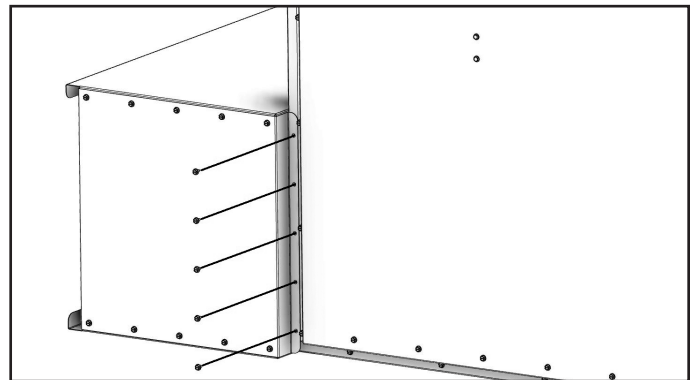

AIR FILTER REPLACEMENT

Insert one 16 x 24 x 1 air filter (not included).

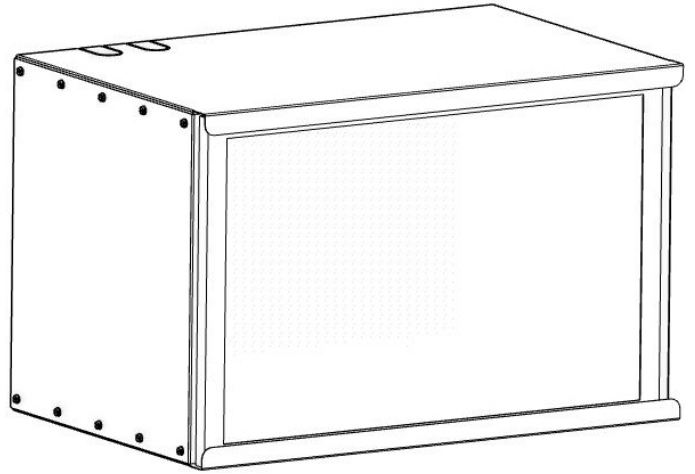
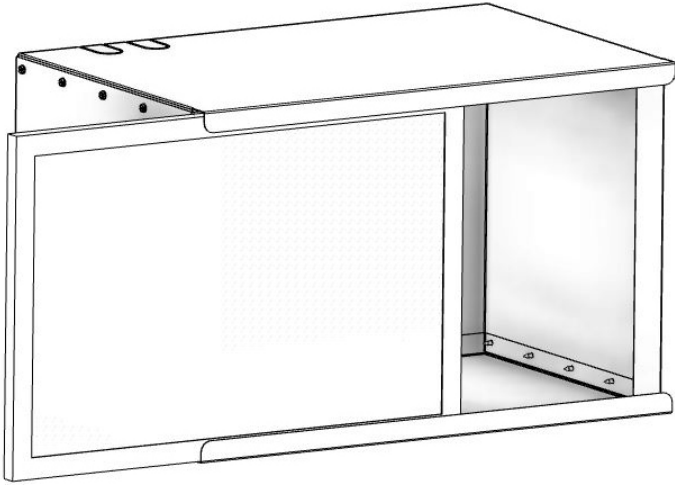

ATTENTION:

- **FAILURE TO FOLLOW THE INFORMATION IN THIS MANUAL WILL CAUSE A HAZARD THAT COULD RESULT IN DEATH, SERIOUS BODILY INJURY, AND/OR PROPERTY DAMAGE.**
- **CHECK YOUR LOCAL CODES. THE INSTALLATION MUST COMPLY WITH THEIR RULINGS.**
- **ALWAYS CONNECT THIS FURNACE TO A CHIMNEY AND VENT TO THE OUTSIDE. NEVER VENT TO ANOTHER ROOM OR INSIDE A BUILDING.**
- **DO NOT CONNECT THIS FURNACE TO AN ALUMINUM TYPE B GAS VENT. THIS IS NOT SAFE AND IS PROHIBITED BY THE NATIONAL FIRE PROTECTION ASSOCIATION CODE. THIS FURNACE REQUIRES A MASONRY OR LISTED FACTORY BUILT CHIMNEY FOR RESIDENTIAL TYPE OR BUILDING HEATING APPLIANCE CHIMNEY. USE A 6" DIAMETER CHIMNEY OR LARGER, THAT IS HIGH ENOUGH TO GIVE A GOOD DRAFT.**
- **INSPECT CHIMNEY CONNECTOR AND CHIMNEY BEFORE AND FREQUENTLY DURING THE HEATING SEASON FOR ANY DEPOSIT OF CREOSOTE OR SOOT WHICH MUST BE REMOVED.**
- **PROVIDE AIR FOR COMBUSTION INTO THE ROOM WHERE THE FURNACE IS LOCATED. IF THE INTAKE IS NOT IN THE SAME ROOM, AIR MUST HAVE FREE ACCESS TO THE ROOM.**
- **CAST IRON PARTS MUST BE "SEASONED" TO AVOID CRACKING, BUILD ONLY SMALL FIRES ON FIRST USE.**
- **TO PREVENT INJURY, DO NOT ALLOW ANYONE TO USE THIS FURNACE WHO IS UNFAMILIAR WITH THE CORRECT OPERATION OF THE FURNACE.**

CAUTION

GASES THAT ARE DRIVEN FROM FRESH WOOD MUST BE BURNED OR THEY WILL ACCUMULATE AND EXPLODE. NEVER SMOTHER A FIRE WHEN ADDING FRESH WOOD.

DANGER: RISK OF FIRE OR EXPLOSION.

DO NOT BURN GARBAGE, GASOLINE, DRAIN OIL, OR OTHER FLAMMABLE LIQUIDS.

WARNING: FIRE HAZARD.

- **DO NOT OPERATE WITH FIRE DRAFT EXCEEDING 0.06" W.C.**
- **DO NOT STORE FUELS, PAINTS, THINNERS, FLAMMABLE LIQUIDS, OR OTHER HIGHLY VOLATILE SUBSTANCES IN THE FURNACE ROOM.**

CAUTION!

CLEANOUT OF THE COMBUSTION CHAMBER, FLUE PIPE, AND CHIMNEY IS ESPECIALLY IMPORTANT AT THE END OF THE HEATING SEASON TO MINIMIZE CORROSION DURING THE SUMMER MONTHS CAUSED BY MOISTURE ACCUMULATING IN LEFT-OVER ASH.

CAUTION!

INSPECT FLUE PIPES, FLUE PIPE JOINTS AND FLUE PIPE SEALS REGULARLY TO ENSURE THAT SMOKE AND FLUE GASES ARE NOT DRAWN INTO, AND CIRCULATED BY, THE AIR CIRCULATION SYSTEM.

SAFETY NOTICE:

IF THIS FURNACE IS NOT PROPERLY INSTALLED, A HOUSE FIRE MAY RESULT. FOR YOUR SAFETY, FOLLOW THE INSTALLATION DIRECTIONS. CONTACT LOCAL BUILDING OR FIRE OFFICIALS ABOUT RESTRICTIONS AND INSTALLATION INSPECTION REQUIREMENTS IN YOUR AREA. IF NOT ALREADY INSTALLED, WE RECOMMEND THAT SMOKE DETECTORS BE INSTALLED.

CAUTION:

HOT SURFACES! KEEP CHILDREN AWAY. DO NOT TOUCH DURING OPERATION.

FOR CUSTOMER SERVICE CALL: 800-750-2723 EXT 5050



We recommend that our woodburning hearth products be installed and serviced by professionals who are certified in the U.S. by the National Fireplace Institute® (NFI) as NFI Woodburning Specialists or who are certified in Canada by Wood Energy Technical Training (WETT).



US Stove highly recommends your stove be installed by a qualified NFI (US) or WETT (Canada) technician. To find the nearest qualified installer, go to:

<https://nficertified.org>,

<https://www.wettinc.ca/>

FLOOR PROTECTOR

The furnace must be placed on solid concrete, solid masonry, or when installed on a combustible floor, on a floor protector. The floor protector is required to provide heat, live ember, and ash protection and must be of a non-combustible, continuous solid surface to protect against infiltration of live embers and ash. Floor protection must have an R-Value of at least 1.4. Refer to floor protector manufacturer's instructions for installation directions. The floor protector or non-combustible floor must extend under the furnace and beyond each side as shown below.

Dimension		Inch	mm
A	Front	24	609.6
B	Flue Rear	2	50.8
C	Side	8	203.2

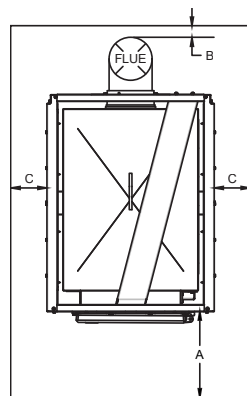

CLEARANCES TO COMBUSTIBLES

The installation of this furnace includes supplying electrical power, return air ductwork, and supply air ductwork. This furnace may be installed as a stand alone

wood furnace only. See installation section in this manual to ensure proper assembly, installation and operation of your new furnace. If installing in an area with a fan it should not be allowed to create negative pressure in the room where the furnace is installed. When locating your furnace ensure the required maintenance clearances are maintained. Your furnace must be installed as shown in this manual and in compliance with all local and national codes. It is of the utmost importance that the clearances to combustible materials be strictly adhered to during installation of the furnace. Refer to the table and diagrams below for minimum required clearances.

Dimension		Inch	mm
D	Backwall To Furnace	26	661
E	Sidewall To Furnace	16	407
F	Sidewall To Flue	25	635
G	Backwall To Flue	18	458
H	Supply Duct (first 6 feet)	6	153
J	Supply Duct (after first 6 feet)	2	51
K	Minimum Duct Height	8	204
L	Top Of Door To Ceiling	48	1220
M	Minimum Ceiling Height	75	1905

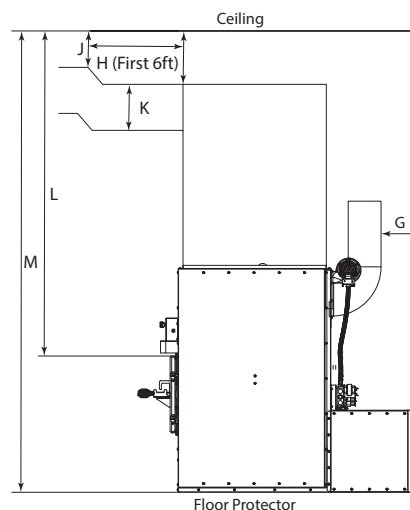
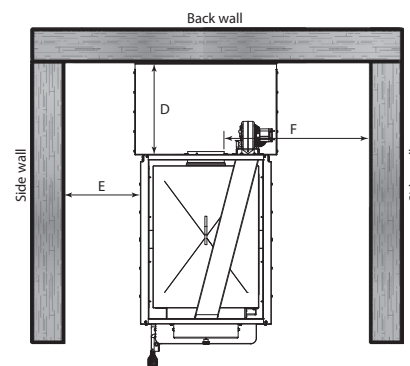

DUCT WORK

We strongly recommend that the hot air ductwork be installed by a home heating specialist. If doing the installation yourself, consult a qualified heating technician and follow his recommendations as to the safest and most efficient method of installation.

SUPPLY AIR

The supply air duct shall be constructed of metal in accordance with NFPA 90B, 2-1.1. The plenums installed to the furnace shall be constructed of metal in accordance with NFPA 90B, 2-1.3. When installing this furnace the supply air plenum is to have a minimum height of 24" (610mm) if the top of the first vertical section is not flush with the top of the first horizontal section of ductwork. If the top of the plenum is flush with the top of the first horizontal section of ductwork then the minimum height is 15" (381mm).

RETURN AIR

The return air intake on the furnace is on the rear of the unit. The ductwork must be mechanically attached to the unit or blower box with sheet metal screws to ensure a proper operation.

STAND ALONE INSTALLATION

When installing this stand alone furnace, ensure all local codes and all instructions in this manual are followed, including clearance to combustibles, floor protector specifications and safety warnings.

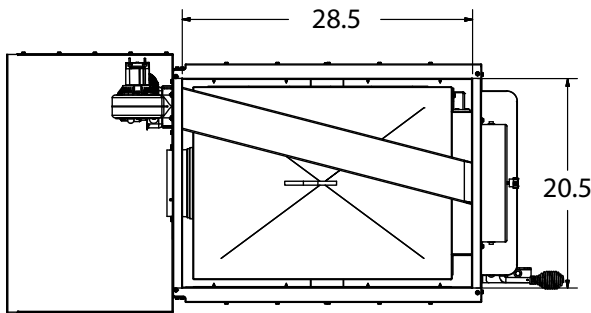

Supply Air Duct Work Outlet Size

LISTED FACTORY BUILT CHIMNEY

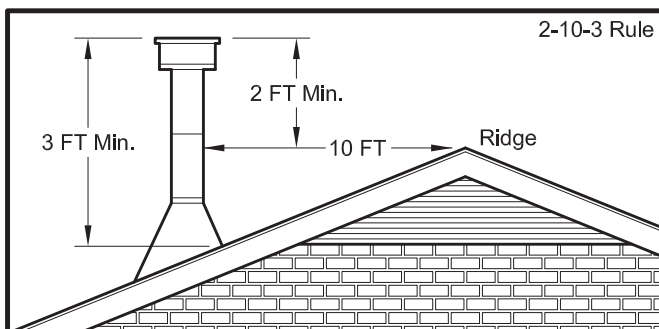

Your wood furnace may be hooked up with a factory built or masonry chimney, matching the diameter of the exhaust. If you are using a factory built chimney, it must comply with UL 103 or CSA-B365 standard; therefore it must be a Type HT (2100°F). It is extremely important that it be installed according to the manufacturer's specifications.

If you are using a masonry chimney, it is important that it be built in compliance with the specifications of the National Building Code. It must be lined with fire clay bricks, metal or clay tiles sealed together with fire cement. (Round flues are the most efficient).

The interior diameter of the chimney flue must be identical to the furnace smoke exhaust. A flue which is too small may cause draft problems, while a large flue favors rapid cooling of the gas, and hence the build-up of creosote and the risk of chimney fires. Note that it is the chimney and not the furnace which creates the draft effect; your furnace's performance is directly dependent on an adequate draft from your chimney.

Do not connect this unit to a chimney flue serving another appliance.

The following recommendations may be useful for the installation of your chimney:

- It must rise above the roof at least 3' (0.9m) from the uppermost point of contact.
- The exterior portion should be double or triple wall pipe to ensure proper draft.
- The chimney must exceed any part of the building or other obstruction within a 10' (3.04m) distance by a height of 2' (0.6m).
- Installation of an interior chimney is always preferable to an exterior chimney. The interior chimney will be hotter than an exterior chimney that is being cooled by the ambient air outside the house. Therefore the gas which circulates will cool slower, thus reducing the build-up of creosote and the risk of chimney fires.
- The draft caused by the tendency for hot air to rise will be increased with an interior chimney.
- Using a fire screen at the extremity of the chimney requires regular inspection in order to ensure that it is not obstructed thus blocking the draft, and it should be cleaned when used regularly.

IMPORTANCE OF PROPER DRAFT

Draft is the force which moves air from the appliance up through the chimney. The amount of draft in your chimney depends on the length of the chimney, local geography, nearby obstructions and other factors. Too

much draft may cause excessive temperatures in the appliance. Inadequate draft may cause back puffing into the room and ‘plugging’ of the chimney. Inadequate draft will cause the appliance to leak smoke into the room through appliance and chimney connector joints. An uncontrollable burn or excessive temperature indicates excessive draft. Do not operate with the flue draft exceeding .06 water column/14.93 Pascals. The draft can be checked with a draft gauge or manometer. Take into account the chimney’s location to ensure it is not too close to neighbors or in a valley which may cause unhealthy or nuisance conditions.

MASONRY CHIMNEY

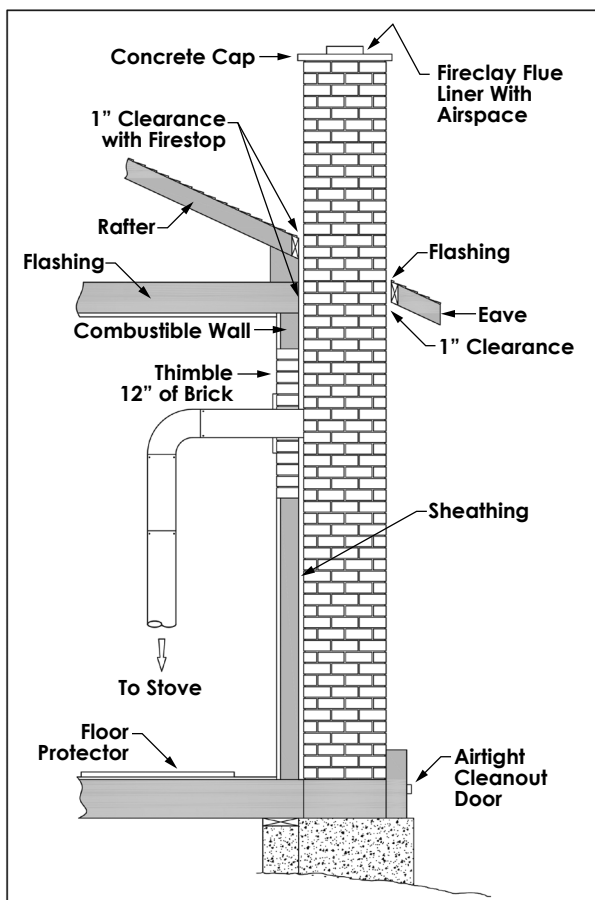

CAUTION:

BE SURE THAT IF A MASONRY CHIMNEY IS USED, IT IS SAFELY CONSTRUCTED AND IN GOOD REPAIR. HAVE THE CHIMNEY INSPECTED BY THE FIRE DEPARTMENT OR AN INSPECTOR.

Ensure that a masonry chimney meets the minimum standards of the National Fire Protection Association (NFPA) by having it inspected by a professional. Make sure there are no cracks, loose mortar or other signs of deterioration and blockage. Have the chimney cleaned

before the furnace is installed and operated. When connecting the furnace through a combustible wall to a masonry chimney, special methods are needed as explained in the “Combustible Wall Chimney Connector Pass-Throughs” Section.

WARNING:

DO NOT CONNECT THIS FURNACE TO A CHIMNEY FLUE SERVING ANOTHER APPLIANCE.

COMBUSTIBLE WALL CHIMNEY CONNECTOR PASS-THROUGHS

METHOD A - 12” (304.8 mm) Clearance to Combustible Wall Member: Using a minimum thickness 3.5” (89 mm) brick and a 5/8” (15.9 mm) minimum wall thickness clay liner, construct a wall pass-through. The clay liner must conform to ASTM C315 (Standard Specification for Clay Fire Linings) or its equivalent. Keep a minimum of 12” (304.8 mm) of brick masonry between the clay liner and wall combustibles. The clay liner shall run from the brick masonry outer surface to the inner surface of the chimney flue liner but not past the inner surface. Firmly grout or cement the clay liner in place to the chimney flue liner.

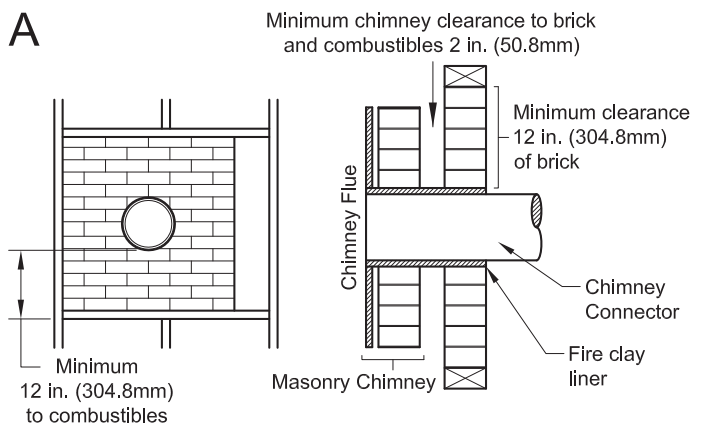

METHOD B - 9” (228.6 mm) Clearance to Combustible Wall Member: Using a 6” (152.4 mm) inside diameter, listed, factory-built Solid-Pak chimney section with insulation of 1” (25.4 mm) or more, build a wall pass-through with a minimum 9” (228.6 mm) air space between the outer wall of the chimney length and wall combustibles. Use sheet metal supports fastened securely to wall surfaces on all sides, to maintain the 9” (228.6 mm) air space. When fastening supports to chimney length, do not penetrate the chimney liner (the inside wall of the Solid-Pak chimney). The inner end of the Solid-Pak chimney section shall be flush with the inside of the masonry chimney flue, and sealed with a non-water soluble refractory cement. Use this cement to also seal to the brick masonry penetration.

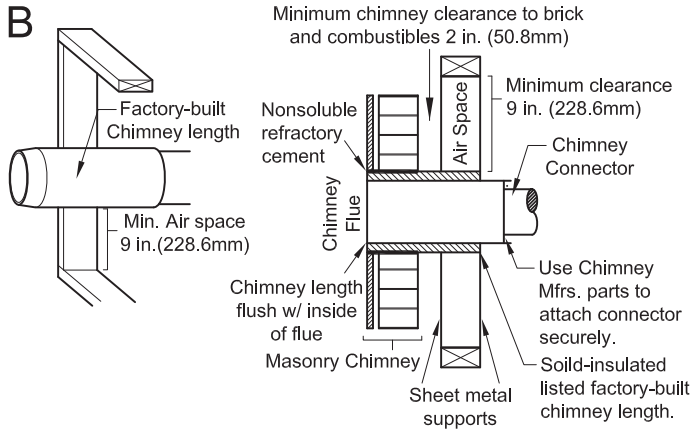

METHOD C - 6" (152.4 mm) Clearance to Combustible Wall Member: Starting with a minimum 24 gage (.024" [.61 mm]) 6" (152.4 mm) metal chimney connector, and a minimum 24 gage ventilated wall thimble which has two air channels of 1" (25.4 mm) each, construct a wall pass-through. There shall be a minimum 6" (152.4 mm) separation area containing fiberglass insulation, from the outer surface of the wall thimble to wall combustibles. Support the wall thimble, and cover its opening with a 24-gage minimum sheet metal support. Maintain the 6" (152.4 mm) space. There should also be a support sized to fit and hold the metal chimney connector. See that the supports are fastened securely to wall surfaces on all sides. Make sure fasteners used to secure the metal chimney connector do not penetrate chimney flue liner.

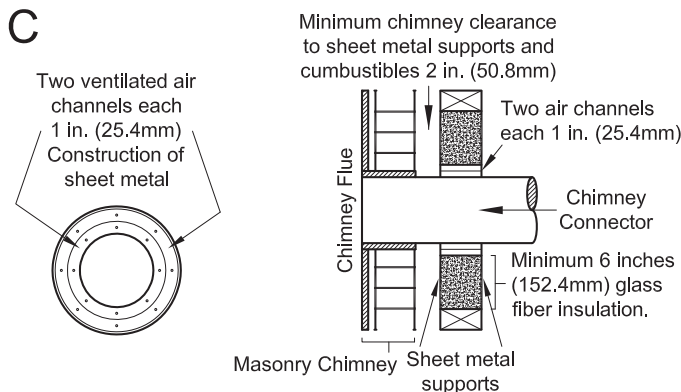

METHOD D - 2" (50.8 mm) Clearance to Combustible Wall Member: Start with a solid-pak listed factory built chimney section at least 12" (304 mm) long, with insulation of 1" (25.4 mm) or more, and an inside diameter of 8" (2 inches [51 mm] larger than the 6" [152.4 mm] chimney connector). Use this as a pass-through for a minimum 24-gauge single wall steel chimney connector. Keep solid-pak section concentric with and spaced 1" (25.4 mm) off the chimney connector by way of sheet metal support plates at both ends of chimney section. Cover opening with and support chimney section on both sides with 24 gage minimum sheet metal supports. See

that the supports are fastened securely to wall surfaces on all sides. Make sure fasteners used to secure chimney flue line do not penetrate the inner liner.

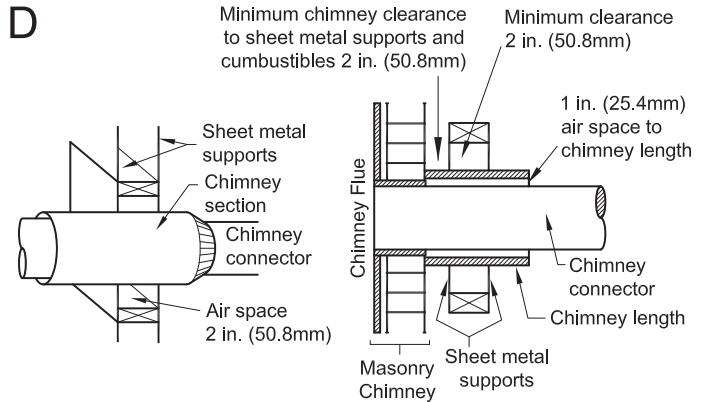

NOTES:

- Connectors to a masonry chimney, excepting method B, shall extend in one continuous section through the wall pass-through system and the chimney wall, to but not past the inner flue liner face.
- A chimney connector shall not pass through an attic or roof space, closet or similar concealed space, or a floor, or ceiling.

CHIMNEY CONNECTOR

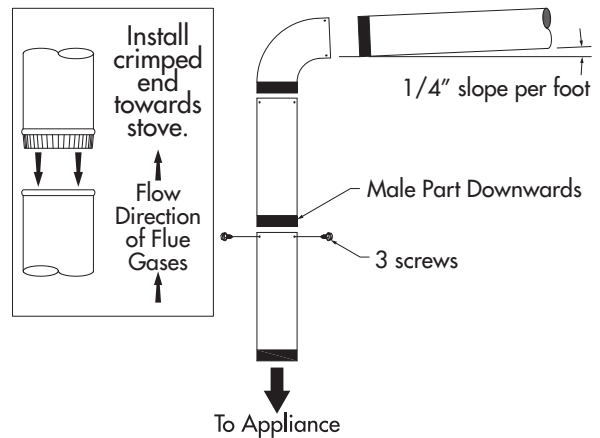

Your chimney connector and chimney must have the same diameter as the furnace outlet. If this is not the case, we recommend you contact your dealer in order to ensure there will be no problem with the draft.

The furnace pipe must be made of aluminized or cold roll steel with a minimum thickness of 0.021" or 0.53 mm. It is strictly forbidden to use galvanized steel.

Your connector should be assembled in such a way that the male section (crimped end) of the pipe faces down. Attach each of the sections to one another with three equidistant metal screws. Seal the joints with furnace cement.

The pipe must be short and straight. All sections installed horizontally must slope at least 1/4 inch per foot, with the upper end of the section toward the chimney. Any installation with a horizontal run of furnace pipe must conform to NFPA 211. You may contact NFPA (National Fire Protection Association) and request the latest edition of the NFPA Standard 211.

To ensure a good draft, the total length of the furnace pipe should never exceed 8' to 10' (2.4m to 3.04 m). (Except for cases of vertical installation, cathedral-roof style where the smoke exhaust system can be much longer and connected without problem to the chimney at the ceiling of the room).

There should never be more than two 90 degrees elbows in the smoke exhaust system.

Installation of a "barometric draft stabilizer" (fireplace register) on a smoke exhaust system is prohibited.

Do not use with a flue damper. With a controlled combustion wood furnaces the draft is regulated upon intake of the combustion air in the furnace and not at the exhaust.

FACTORY BUILT CHIMNEY

When a metal prefabricated chimney is used, the manufacturer's installation instructions must be followed. You must also purchase (from the same manufacturer) and install the ceiling support package or wall pass-through and "T" section package, firestops (where needed), insulation shield, roof flashing, chimney cap, etc. Maintain proper clearance to the structure as recommended by the manufacturer. The chimney must be the required height above the roof or other obstructions for safety and proper draft operation.

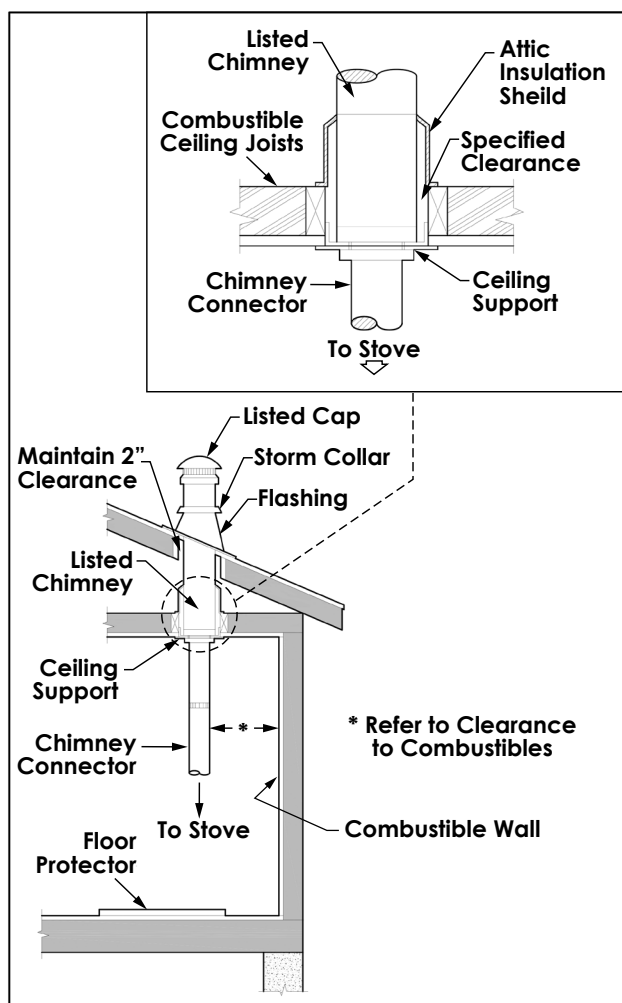

NEVER OPERATE THIS PRODUCT WHILE UNATTENDED

CAUTIONS: HOUSE FIRE HAZARDS

- **DO NOT STORE WOOD ON FLOOR PROTECTOR, UNDERNEATH STOVEPIPE(S) OR ANYWHERE WITHIN CLEARANCES TO COMBUSTIBLE SURFACES SPECIFIED FOR THIS APPLIANCE.**
- **NEVER OPERATE WITH SECONDARY TUBES, FIBERBOARD, OR INSULATION REMOVED.**

OPERATING SAFETY PRECAUTIONS

- **NEVER OVERFIRE THIS APPLIANCE BY BUILDING EXCESSIVELY HOT FIRES AS A HOUSE/BUILDING FIRE MAY RESULT. YOU ARE OVERFIRING THE APPLIANCE IF IT BEGINS TO GLOW OR TURN RED.**
- **NEVER BUILD EXCESSIVELY LARGE FIRES IN THIS TYPE OF APPLIANCE AS DAMAGE TO THE FIREBOX OR SMOKE LEAKAGE MAY RESULT.**
- **DO NOT BUILD FIRE TOO CLOSE TO THE GLASS.**
- **HOT WHILE IN OPERATION. KEEP CHILDREN, CLOTHING, AND FURNITURE AWAY. CONTACT MAY CAUSE SKIN BURNS. DO NOT TOUCH THE APPLIANCE UNTIL IT HAS COOLED.**
- **PROVIDE ADEQUATE AIR FOR COMBUSTION TO THE ROOM WHERE THE APPLIANCE IS INSTALLED.**
- **INSPECT CHIMNEY LINER EVERY 60 DAYS. REPLACE LINER IMMEDIATELY IF IT IS RUSTING OR LEAKING SMOKE INTO THE ROOM.**
- **ATTEMPTS TO ACHIEVE HEAT OUTPUT RATES THAT EXCEED FURNACE DESIGN SPECIFICATIONS CAN RESULT IN PERMANENT DAMAGE TO THE FURNACE.**

WARNING: EXPLOSION HAZARD

- **NEVER USE CHEMICALS, GASOLINE, GASOLINE-TYPE LANTERN FUEL, KEROSENE, CHARCOAL LIGHTER FLUID, OR SIMILAR FLAMMABLE LIQUIDS TO START OR "FRESHEN UP" A FIRE IN THE APPLIANCE.**
- **KEEP ALL FLAMMABLE LIQUIDS, ESPECIALLY GASOLINE, OUT OF THE VICINITY OF THE APPLIANCE - WHETHER IN USE OR IN STORAGE.**

Your heating appliance was designed to burn well seasoned natural wood only; no other materials should be burned. Any type of well seasoned natural wood

may be used in your stove, but specific varieties have better energy yields than others. Higher efficiencies and lower emissions generally result when burning air dried seasoned hardwoods, as compared to softwoods or too green or freshly cut hardwoods. The following resources can assist in learning the burn characteristics of various species of wood:

<http://firewoodresource.com/firewood-btu-ratings/>; or <https://forestry.usu.edu/forest-products/wood-heating>

The operation of this wood furnace in a manner inconsistent with the owner's manual will void your warranty and is also against federal regulations. Waste and other flammable materials should not be burned in your stove. DO NOT BURN:

1. Garbage;
2. Lawn clippings or yard waste;
3. Materials containing rubber, including tires;
4. Materials containing plastic;
5. Waste petroleum products, paints or paint thinners, or asphalt products;
6. Materials containing asbestos;
7. Construction or demolition debris;
8. Railroad ties or pressure-treated wood;
9. Manure or animal remains;
10. Saltwater driftwood or other previously salt water-saturated materials;
11. Unseasoned wood; or
12. Paper products, cardboard, plywood, or particleboard. The prohibition against burning these materials does not prohibit the use of fire starters made from paper, cardboard, sawdust, wax, and similar substances to start a fire in an affected wood furnace.

Burning these materials may result in the release of toxic fumes or render the furnace ineffective and cause smoke. Deadwood lying on the forest floor should be considered wet and requires full seasoning time. Standing deadwood can usually be considered to be about 2/3 seasoned. Smaller pieces of wood will dry faster. All logs exceeding 6" in diameter should be split. The wood should not be stored directly on the ground. Air should circulate through the logs. A 24" to 48" air space should be left between each row of logs, which should be placed in the sunniest location possible. The upper layer of wood should be protected from the element but not the sides. A good indicator of if the wood is ready to burn is to check the

piece ends. If cracks are radiating in all directions from the center then the wood should be dry enough to burn. If your wood sizzles in the fire, even though the surface is dry, it may not be fully cured and should be seasoned longer. It is **EXTREMELY IMPORTANT** that you use **DRY WOOD** only in your wood stove. The wood should have dried for 9 to 15 months, such that the humidity content (in weight) is reduced below 20% of the weight of the log. It is very important to keep in mind that even if the wood has been cut for one, two, or even more years, it is not necessarily dry, if it has been stored in poor conditions. Under extreme conditions, it may rot instead of drying. This point cannot be overstressed; the vast majority of the problems related to the operation of a wood stove is caused by the fact that the wood used was too damp or had dried in poor conditions. These problems can be:

- ignition problems
- creosote build-up causing chimney fires
- low energy yield
- blackened windows
- incomplete log combustion

Do not burn manufactured logs made of wax impregnated sawdust or logs with any chemical additives.

TESTING YOUR WOOD

- When the furnace is thoroughly warmed, place one piece of split wood (about five inches in diameter) parallel to the door on the bed of red embers.
- Adjust all air controls to their maximum settings and close the door. If ignition of the piece is accomplished within 90 seconds from the time it was placed in the furnace, your wood is correctly dried. If ignition takes longer, your wood is damp.

If your wood hisses and water or vapor escapes at the ends of the piece, your wood is soaked or freshly cut (green). Do not use this wood in your stove. Large amounts of creosote could be deposited in your chimney, creating potential conditions for a chimney fire.

POWER FAILURE

DO NOT add additional fuel after a power failure, remove all air filters and reduce combustion air to a minimum. Observe furnace closely until power is restored.

TAMPER WARNING

This wood furnace has a manufacturer-set minimum low burn rate that must not be altered. It is against federal regulations to alter this setting or otherwise operate this

wood furnace in a manner inconsistent with operating instructions in this manual.

EFFICIENCIES

Efficiencies can be based on either the lower heating value (LHV) or the higher heating value (HHV) of the fuel. The lower heating value is when water leaves the combustion process as a vapor, in the case of woodstoves the moisture in the wood being burned leaves the stove as a vapor. The higher heating value is when water leaves the combustion process completely condensed. In the case of woodstoves this would assume the exhaust gases are room temperature when leaving the system, and therefore calculations using this heating value consider the heat going up the chimney as lost energy. Therefore, efficiency calculated using the lower heating value of wood will be higher than efficiency calculated using the higher heating value. The best way to achieve optimum efficiencies is to learn the burn characteristic of your appliance and burn well-seasoned wood. Higher burn rates are not always the best heating burn rates; after a good fire is established a lower burn rate may be a better option for efficient heating. A lower burn rate slows the flow of usable heat out of the home through the chimney, and it also consumes less wood.

NOTICE - INITIAL BURNS TO CURE PAINT

BECAUSE OF THE HIGH OPERATING TEMPERATURES, THIS APPLIANCE IS COATED WITH A SPECIAL HIGH TEMP PAINT WHICH REQUIRES A SERIES OF LOW TO MEDIUM BURNS TO FULLY CURE FOR DURABILITY AND A LIFETIME OF SERVICE.

Proper curing of the high-temp paint requires a series of three initial burns. The appliance should be allowed to cool off between each burn. The first two burns should be small fires and low temperatures (250°F) for a duration of 20 minutes each. The third fire should be at a temperature of approximately 500°F for 20 minutes. Provide adequate cross ventilation to clear any smoke or odor caused by initial firings.

Notice: Use solid wood fuel only! Do not burn garbage, or flammable fluids. Do not use coal. This appliance is not designed to accommodate the air flow (draft) required to properly burn coal or coal products. Do not elevate the fire using grates or irons. Build the fire directly on the firebrick.

FUELING INSTRUCTIONS

To ensure this unit produces the optimal minimum emissions it is critical that only well-seasoned cordwood is burned. Burning unseasoned wet wood only hurts

your stoves efficiency and leads to accelerated creosote buildup in your chimney. Be considerate of the environment and only burn dry wood.

CAUTION:
DO NOT LEAVE APPLIANCE UNATTENDED WITH THE DOOR OPEN.

WARNINGS:
<ul style="list-style-type: none">• NEVER OVERFIRE YOUR STOVE. IF ANY PART OF THE STOVE STARTS TO GLOW RED, OVER FIRING IS HAPPENING. READJUST THE AIR INTAKE CONTROL AT A LOWER SETTING.• THE INSTALLATION OF A LOG CRADLE OR GRATES IS NOT RECOMMENDED IN YOUR WOOD STOVE. BUILD FIRE DIRECTLY ON FIREBRICK.• NEVER PUT WOOD ABOVE THE FIREBRICK LINING OF THE FIREBOX.• ATTEMPTS TO ACHIEVE HEAT OUTPUT RATES THAT EXCEED FURNACE DESIGN SPECIFICATIONS CAN RESULT IN PERMANENT DAMAGE TO THE FURNACE.

GENERAL FURNACE OPERATION

Honeywell Limit Control

This device, mounted in the ductwork, just above the air discharge atop the furnace, works in conjunction with a wall thermostat, operating the distribution blowers and the combustion fan on the rear of the furnace. The factory settings are 100/150/200. The wall thermostat setting operates the ON time of the combustion fan. If the temperature is below the setting on the wall thermostat, the combustion fan will come ON. (Recommended setting at 5 to 10 degrees higher than other heating thermostats.) The first two set points on the limit control operates the distribution blowers. When the furnace plenum temperature reaches the second set point on the limit control, the distribution blowers will come on. If the temperature falls to the first set point, the distribution blower will shut-off. When the furnace reaches the third set point on the limit control, the combustion fan will shut-off. Once the temperature falls below that set point and the wall thermostat is still calling for heat, the combustion fan will turn back ON. The 200° is a Factory Preset Limit for the combustion fan and should never be changed. Doing so could result in excessive firebox temperatures and could permanently damage your firebox.

FURNACE LOADING PROCEDURE

Starting your Furnace

- When lighting the furnace, the wall thermostat should be set to its MAX setting so that the combustion fan is ON. Start the fire with approximately 12 lbs. of kindling, which will be several small strips of wood, 1-1/2 to 2-1/2 inches wide, approximately 12 to 15 inches deep in the bottom of the firebox. Leave the fuel loading door slightly open to ensure good ignition of the kindling. Make sure the combustion fan is ON and its damper is closed, then pull the knob/loop on the front of the unit to prop open the barometric dampers.
- Once the kindling is fully ignited, add another 12 to 15 lbs. of kindling, which will be around the same amount as the initial load.
- Leave the door slightly open for three to five minutes (3-5 min) to ensure full ignition of the second kindling load.
- After the second load of kindling is fully ignited, you can close the door and push the knob/loop on the front of the unit back in to allow the barometric dampers to function freely. After 15 minutes, fully open the damper on the combustion fan.
- Once the kindling burns down to about 8 lbs., which should be to the point that the kindling will break up into a full bed of coals, the preload can be added into the firebox. The preload should consist of around 40 pounds of properly seasoned cord wood, which should be about 6 to 8 pieces of wood.
- After loading the preload, close the door, and make certain the combustion fan is ON.
- Allow about one hour (1hr) for the preload to burn down to around 10-12 lbs. or when all the preload wood will break up into coals. You should now have a coal bed that is several inches deep in the bottom of the firebox.
- The purpose of the preload burn is to establish a proper coal bed prior to inserting the main load of wood. Having a proper coal bed is the key to a complete ignition of the main wood load and to maintain the correct firebox temperatures to get the best emissions and efficiency output of the furnace.
- After you have completed the preload burn, you may insert your main firewood load.
- The main load should be the same size or amount as the preload, approximately 40 pounds of cord wood, 6 to 8 pieces.
- Try to keep gaps between the pieces of wood to help with the ignition and maintain a good fire.

MAIN FIREWOOD LOAD

- Ensure that the combustion fan is ON, and open the feed door to insert the main firewood load.
- After loading, leave the feed door slightly open for five minutes (5 min) to ensure proper ignition, then close the door.
- The damper on the combustion fan should be open.
- Depending on the temperature at which the wall thermostat is set, this will determine the burn duration of the main load. A lower setting on the thermostat should result in a longer burn time as this would allow the combustion fan to remain OFF for longer periods. A higher thermostat setting will cycle the combustion blower ON/OFF more often, resulting in a hotter, but shorter duration burn time of course. However, colder outside temperatures and your home's construction (insulation) will play a big factor in how well the thermostat can maintain it's set temperature.

VISIBLE SMOKE

The amount of visible smoke being produced can be an effective method of determining how efficiently the combustion process is taking place at the given settings. Visible smoke consist of unburned fuel and moisture leaving your stove. Learn to adjust the air settings of your specific unit to produce the smallest amount of visible smoke. Wood that has not been seasoned properly and

has a high wood moisture content will produce excess visible smoke and burn poorly. Use the included moisture meter to ensure your wood has a 20% or less moisture content.

AIR TUBES

The air tubes assembled in this unit are designed to provide an accurate mix of secondary air to ensure the highest efficiency. Any damage or deterioration of these tubes may reduce the efficiency of combustion. The air tubes are held in position by screws or snap pins. Locate these to either side of the tube and remove it to allow the tube to be removed and replaced.

NEVER OPERATE THIS PRODUCT WHILE UNATTENDED

CAUTION:

DO NOT OVERFIRE APPLIANCE. YOU ARE OVERFIRING IF ANY PART OF THE APPLIANCE GLOWS RED. CLOSE THE DOOR AND SHUT DAMPER IMMEDIATELY TO REDUCE THE AIR SUPPLY AND SLOW DOWN THE FIRE.

CAUTION:

SLOW BURNING FIRES FOR EXTENDED USE OR BURNING GREEN WOOD MAY CAUSE EXCESSIVE CREOSOTE BUILD-UP. IGNITION OF CREOSOTE OR OVERFIRING COULD CAUSE A CHIMNEY FIRE. CHIMNEY FIRES BURN EXTREMELY HOT AND MAY IGNITE SURROUNDING COMBUSTIBLE MATERIALS. IN CASE OF A CHIMNEY FIRE, CALL THE FIRE DEPARTMENT IMMEDIATELY!

CREOSOTE & SOOT - FORMATION & NEED FOR REMOVAL

When wood is burned slowly, the products of combustion combine with moisture to form a soot residue which accumulates on the flue lining. When ignited, this soot makes an extremely hot fire. The chimney should be inspected at least twice monthly during the heating season to determine if a creosote or soot build up has occurred. If creosote or soot has accumulated, it should be removed to reduce the risk of a chimney fire. Chimney fires burn very hot. If the chimney catches fire, immediately call the fire department, then reduce the fire by closing the inlet air control. Pour a large quantity of coarse salt, baking soda or cool ashes on top of the fire in the firebox.

CREOSOTE ACCUMULATION CAUSES CHIMNEY FIRES. YOU SHOULD CHECK (OR HAVE CHECKED BY A QUALIFIED CHIMNEY SWEEP) YOUR CHIMNEY FOR CREOSOTE DEPOSITS AT LEAST MONTHLY DURING THE HEATING SEASON. ANY ACCUMULATIONS SHOULD BE REMOVED. COMPLETE CHIMNEY INSPECTIONS AND CLEANING SHOULD BE CONDUCTED ANNUALLY; TYPICALLY, THIS TASK SHOULD BE PERFORMED PRIOR TO EACH HEATING SEASON. IF USING AN EXISTING CHIMNEY, IT MUST BE INSPECTED PRIOR TO THE INSTALLATION OF YOUR NEW WOOD STOVE.

CAUTION

A CHIMNEY FIRE MAY CAUSE IGNITION OF WALL STUDS OR RAFTERS WHICH YOU THOUGHT WERE A SAFE DISTANCE FROM THE CHIMNEY. IF YOU HAVE A CHIMNEY FIRE, HAVE YOUR CHIMNEY INSPECTED BY A QUALIFIED PERSON BEFORE USING AGAIN.

ATTENTION:

THIS FURNACE NEEDS PERIODIC INSPECTION AND REPAIR FOR PROPER OPERATION. IT IS AGAINST FEDERAL REGULATIONS TO OPERATE THIS FURNACE IN A MANNER INCONSISTENT WITH OPERATING INSTRUCTIONS IN THIS MANUAL.

TO PREVENT CREOSOTE BUILD UP

- Always burn dry wood. This allows clean burns and higher chimney temperatures, therefore less creosote deposit.
- Always check for creosote deposit once every two months and have your chimney cleaned at least once a year.
- If a chimney or creosote fire occurs, close all dampers immediately. Wait for the fire to go out and the furnace to cool, then inspect the chimney for damage. If no damage results, perform a chimney cleaning to ensure no more creosote deposits is remaining in the chimney.

CAUTION:

A CHIMNEY FIRE MAY CAUSE IGNITION OF WALL STUDS OR RAFTERS WHICH WERE ASSUMED TO BE A SAFE DISTANCE AWAY FROM THE CHIMNEY. IF A CHIMNEY FIRE OCCURS, HAVE YOUR CHIMNEY INSPECTED BY A QUALIFIED EXPERT BEFORE USING AGAIN.

ASH REMOVAL & DISPOSAL

Never let your ashes get any higher than the pilot air hole. Remove ashes as needed leaving at least 2 inches of ash in the bottom of the firebox. Ashes should be placed in a metal container with a tight-fitting lid. The closed container of ashes should be placed on a noncombustible floor or on the ground, away from all combustible materials, pending final disposal. The ashes should be retained in the closed container until all cinders have thoroughly cooled.

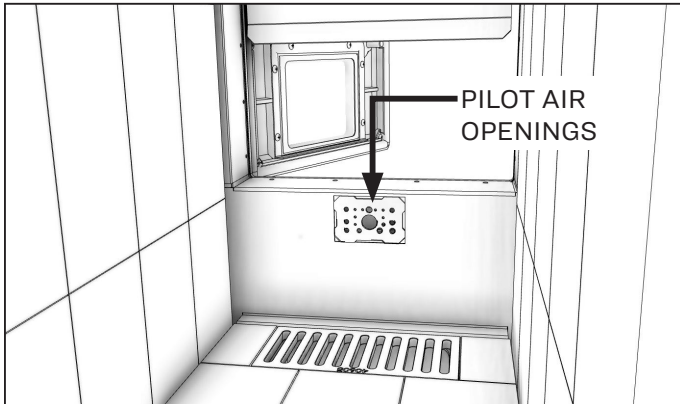

CAUTIONS:

- **ASHES COULD CONTAIN HOT EMBERS EVEN AFTER TWO DAYS WITHOUT OPERATING THE STOVE.**
- **THE ASH PAN CAN BECOME VERY HOT. WEAR GLOVES TO PREVENT INJURY.**
- **NEVER BURN THE STOVE WITH THE ASH TRAP OPEN. THIS WOULD RESULT IN OVER FIRING THE STOVE. DAMAGE TO THE STOVE AND EVEN HOUSE FIRE MAY RESULT.**

SMOKE & CO MONITORS

Burning wood naturally produces smoke and carbon monoxide(CO) emissions. CO is a poisonous gas when exposed to elevated concentrations for extended periods of time. While the modern combustion systems in furnaces drastically reduce the amount of CO emitted out the chimney, exposure to the gases in closed or confined areas can be dangerous. Make sure you stove gaskets and chimney joints are in good working order and sealing properly to ensure unintended exposure. It is recommended that you use both smoke and CO monitors in areas having the potential to generate CO.

GASKET CARE

WARNING:

NEVER OPERATE THE STOVE WITHOUT GASKETS OR WITH BROKEN GASKETS. DAMAGE TO THE STOVE OR EVEN HOUSE FIRE MAY RESULT.

It is recommended that you change the door gasket (which makes your furnace door air tight) once a year, in order to ensure good control over the combustion, maximum efficiency and security. To change the door gasket, simply remove the damaged one. Carefully clean the available gasket groove, apply a high temperature silicone sold for this purpose and install the new gasket. You may light up your furnace again approximately 24 hours after having completed this operation. This unit's feed door uses a 5/8" diameter rope gasket. The door glass on this unit uses a 1 x 1/8 gasket.

ATTENTION:

THIS WOOD FURNACE NEEDS PERIODIC INSPECTION AND REPAIR FOR PROPER OPERATION. IT IS AGAINST FEDERAL REGULATIONS TO OPERATE THIS WOOD FURNACE IN A MANNER INCONSISTENT WITH OPERATING INSTRUCTIONS IN THIS MANUAL.

SERVICE HINTS

Do not expect a furnace to draw. It is the chimney that creates the draft. Smoke spillage into the house or excessive build-up of water or creosote in the chimney are warnings that the chimney is not functioning properly. Correct the problem before using furnace. Possible causes are:

1. The connector pipe may be pushed into the chimney too far, stopping the draft.
2. Do not connect two furnaces or a stove and furnace into the same chimney flue.
3. The chimney used for a furnace must not be used to ventilate the cellar or basement. If there is a cleanout opening at the base of the chimney, it must be closed tightly.
4. If the chimney is operating too cool, water will condense in the chimney and run back into the furnace. Creosote formation will be rapid and may block the chimney. Operate the furnace at a high enough fire to keep the chimney warm, preventing this condensation.

5. If the fire burns well, but sometimes smokes or burns slowly, it may be caused by the chimney top being lower than another part of the house or a nearby tree. The wind blowing over a house or a tree, falls on top of the chimney like water over a dam, beating down the smoke. The top of the chimney should be at least 3 feet above the roof and be at least 2 feet higher than any point of the roof within 10 feet.

CARING FOR PAINTED PARTS

This furnace has a painted outside jacket, which is durable, but it will not stand rough handling or abuse. When installing your furnace, use care in handling. Clean with soap and warm water when furnace is not hot. DO NOT use any acids or scouring soap, as these wear and dull the finish. DISCOLORATION WILL OCCUR IF THE FURNACE IS OVERHEATED. FOLLOW OPERATING INSTRUCTIONS CAREFULLY.

CAUTION:

THE SPECIAL PAINTS USED ON YOUR FURNACE MAY GIVE OFF SOME SMOKE WHILE THEY ARE CURING DURING FIRST FEW FIRES., BUILD SMALL FIRES AT FIRST. THE METAL USED IN CONSTRUCTION OF THE FURNACE AND DUCT WORK HAS A LIGHT COATING OF OIL. THIS COULD GIVE OFF SMOKE AND/OR ODOR FROM REGISTERS WHEN FURNACE IS USED FOR THE FIRST TIME. THIS SHOULD DISAPPEAR AFTER A SHORT PERIOD OF TIME. ONCE THIS BURN-OFF HAS OCCURRED, IT SHOULD NOT REOCCUR.

HOW TO ORDER REPAIR PARTS

For Parts Assistance Call: 800-750-2723 Ext 5051 or Email: parts@usstove.com

The information in this owner's manual is specific to your unit. When ordering replacement parts the information in this manual will help to ensure the correct items are ordered. Before contacting customer service write down the model number and the serial number of this unit. That information can be found on the certification label attached to the back of the unit. Other information that may be needed would be the part number and part description of the item(s) in question. Part numbers and descriptions can be found in the "Repair Parts" section of this manual. Once this information has been gathered you can contact customer service by phone 1-800-750-2723 Ext 5051 or Email parts@usstove.com.

Model Information	
Model Number	
Serial Number	

SETTING LIMIT CONTROL

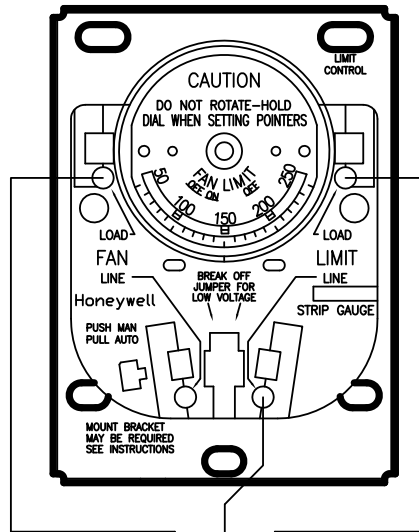
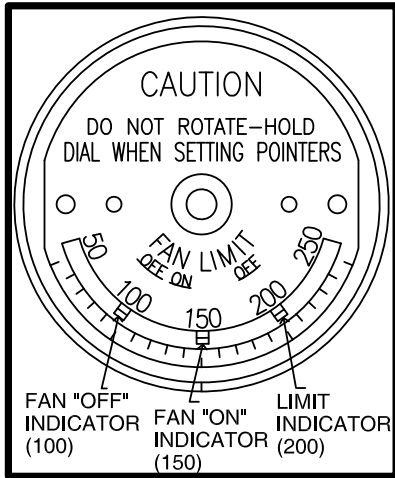

Honeywell
LIMIT SWITCH

WALL THERMOSTAT

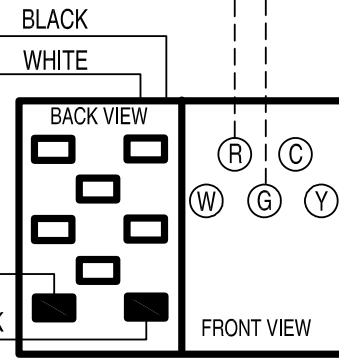
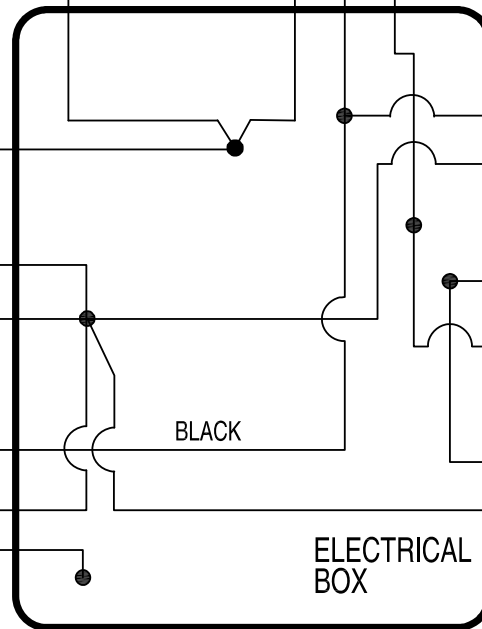
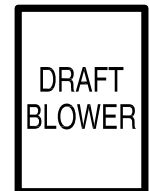
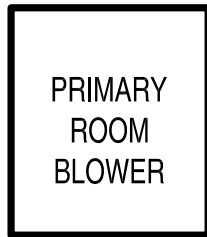
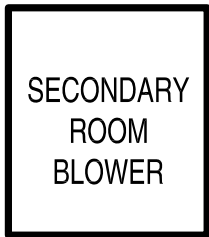
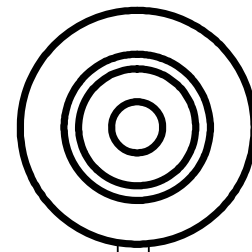

FAN CENTER

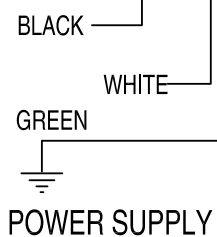

**ALL WIRING MUST BE DONE
BY A QUALIFIED ELECTRICIAN**

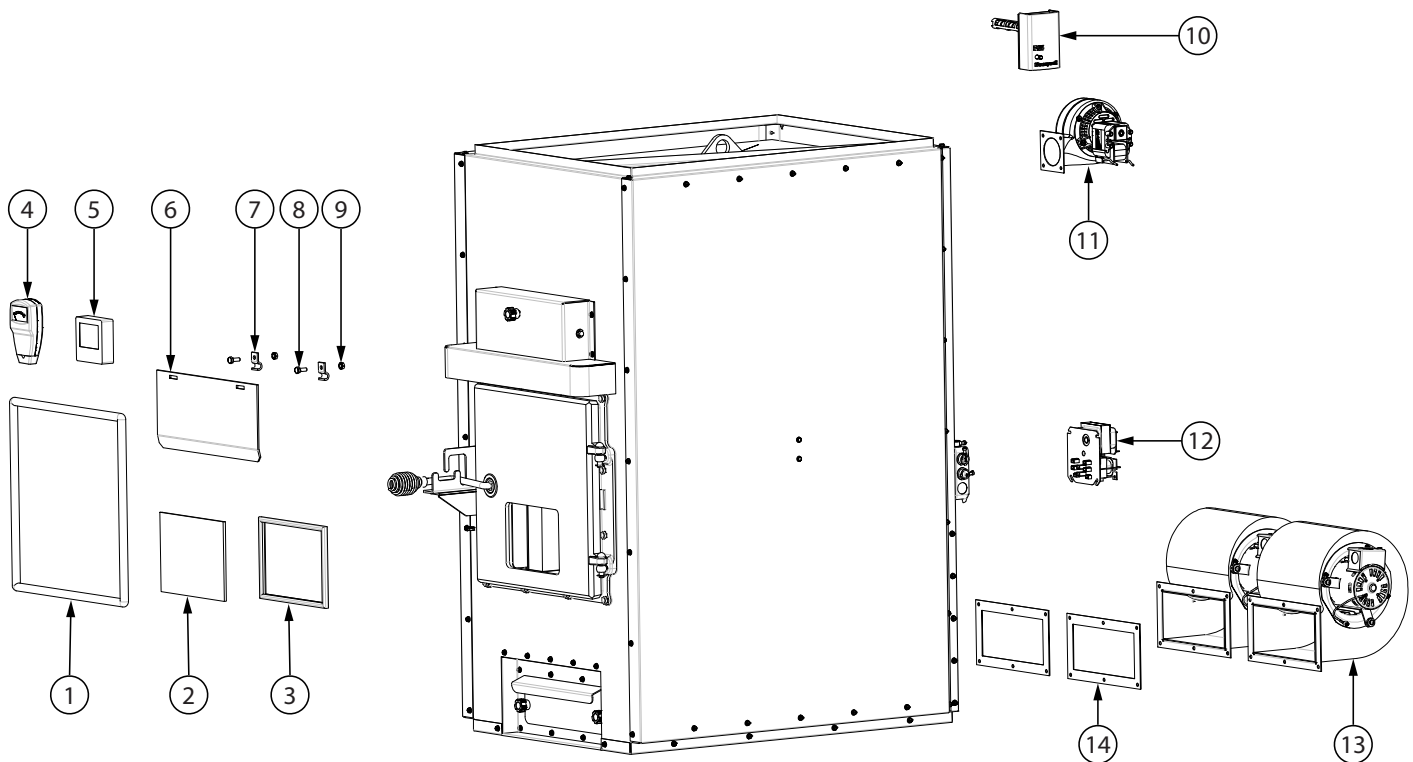

Key	Part #	Description	Qty
1	88126	DOOR GASKET	5ft
2	892686	DOOR GLASS	1
3	88087	GLASS GASKET	30"
4	80697	MOISTURE METER	1
5	80779	DIGITAL WALL THERMOSTAT	1
6	893794	SMOKE CURTAIN	1
7	23787	CLIP, SMOKE DOOR (C000079)	2
8	83339	1/4-20 x 3/4 HEX BOLT	2
9	83250	1/4-20 KEP NUT (BLACK)	2
10	80145	LIMIT CONTROL	1
11	80884	BLOWER, FORCED DRAFT MH	1
12	80130	TRANSFORMER, FAN CENTER	1
13	80594	BLOWER ASSEMBLY	2
14	89319	BLOWER GASKET	2

To order parts:

Call 1-800-750-2723 Ext 5051 or

Email to: parts@usstove.com

IN ORDER TO MAINTAIN WARRANTY, COMPONENTS MUST BE REPLACED USING ORIGINAL MANUFACTURERS PARTS PURCHASED THROUGH YOUR DEALER OR DIRECTLY FROM THE APPLIANCE MANUFACTURER. USE OF THIRD PARTY COMPONENTS WILL VOID THE WARRANTY.

Key	Part #	Description	Qty
1	88353	BAFFLE BLANKET	2
2	893927	TOP BAFFLE (SET OF 2)	1
3	893928	BOTTOM BAFFLE (SET OF 2)	1
4	88360	C-CAST LARGE	10
5	88362	C-CAST SMALL	2
6	88361	C-CAST MEDIUM	2
7	893792	TRUNK ASSEMBLY	1
8	88366	TRUNK GASKET	1
9	893806	RETAINER, BRICK	1
10	89066A	THIN BRICK (4-1/2 x 9) PUMICE	8
11	893807	RETAINER, BRICK	1
12	D2030010	THICK BRICK STRAIGHTS (4-1/2 X 9) PUMICE	26
13	893929	THICK BRICK STRAIGHTS (4-1/2 X 9) PUMICE	2
14	40605	CAST GRATE	1

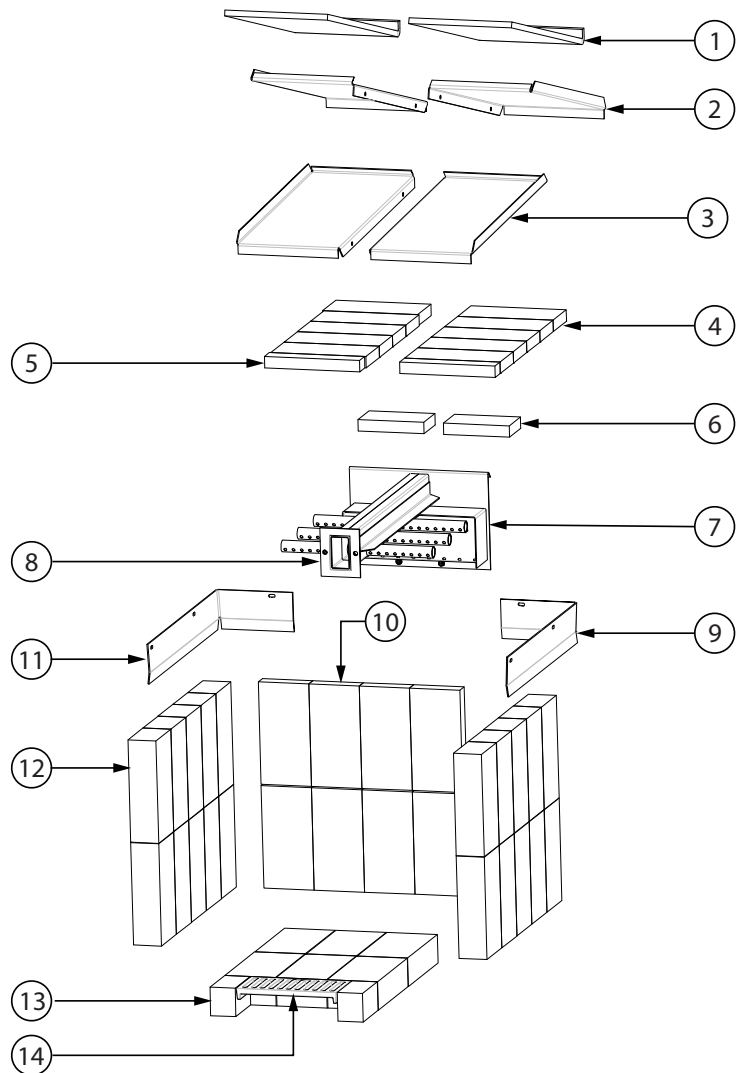

To order parts:

Call 1-800-750-2723 Ext 5051 or

Email to: parts@usstove.com

IN ORDER TO MAINTAIN WARRANTY, COMPONENTS MUST BE REPLACED USING ORIGINAL MANUFACTURERS PARTS PURCHASED THROUGH YOUR DEALER OR DIRECTLY FROM THE APPLIANCE MANUFACTURER. USE OF THIRD PARTY COMPONENTS WILL VOID THE WARRANTY.

SERVICE RECORD



It is recommended that your heating system is serviced regularly and that the appropriate Service Interval Record is completed.

SERVICE PROVIDER

Before completing the appropriate Service Record below, please ensure you have carried out the service as described in the manufacturer's instructions. Always use the manufacturer's specified spare part when replacement is necessary.

Service 01	Date: _____
Engineer Name: _____	
License No.: _____	
Company: _____	
Telephone No.: _____	
Stove Inspected: <input type="checkbox"/>	Chimney Swept: <input type="checkbox"/>
Items Replaced: _____	

Service 02	Date: _____
Engineer Name: _____	
License No.: _____	
Company: _____	
Telephone No.: _____	
Stove Inspected: <input type="checkbox"/>	Chimney Swept: <input type="checkbox"/>
Items Replaced: _____	

Service 03	Date: _____
Engineer Name: _____	
License No.: _____	
Company: _____	
Telephone No.: _____	
Stove Inspected: <input type="checkbox"/>	Chimney Swept: <input type="checkbox"/>
Items Replaced: _____	

Service 04	Date: _____
Engineer Name: _____	
License No.: _____	
Company: _____	
Telephone No.: _____	
Stove Inspected: <input type="checkbox"/>	Chimney Swept: <input type="checkbox"/>
Items Replaced: _____	

Service 05	Date: _____
Engineer Name: _____	
License No.: _____	
Company: _____	
Telephone No.: _____	
Stove Inspected: <input type="checkbox"/>	Chimney Swept: <input type="checkbox"/>
Items Replaced: _____	

Service 06	Date: _____
Engineer Name: _____	
License No.: _____	
Company: _____	
Telephone No.: _____	
Stove Inspected: <input type="checkbox"/>	Chimney Swept: <input type="checkbox"/>
Items Replaced: _____	

Service 07	Date: _____
Engineer Name: _____	
License No.: _____	
Company: _____	
Telephone No.: _____	
Stove Inspected: <input type="checkbox"/>	Chimney Swept: <input type="checkbox"/>
Items Replaced: _____	

Service 08	Date: _____
Engineer Name: _____	
License No.: _____	
Company: _____	
Telephone No.: _____	
Stove Inspected: <input type="checkbox"/>	Chimney Swept: <input type="checkbox"/>
Items Replaced: _____	

