

INSTALLER: LEAVE THIS MANUAL WITH THE APPLIANCE.
CONSUMER: RETAIN THIS MANUAL FOR FUTURE REFERENCE.
NEVER LEAVE CHILDREN OR OTHER AT RISK INDIVIDUALS ALONE WITH THE APPLIANCE.



INSTALLATION AND OPERATING INSTRUCTIONS

CERTIFIED UNDER CANADIAN AND AMERICAN NATIONAL STANDARDS: CR97-003 • CAN-2.21-M85 • IAS US. 4-96

CERTIFIED FOR CANADA AND UNITED STATES USING ANSI/CSA METHODS.

SAFETY INFORMATION

WARNING

If the information in these instructions are not followed exactly, a fire or explosion may result causing property damage, personal injury or loss of life.

- Do not store or use gasoline or other flammable vapors and liquids in the vicinity of this or any other appliance.
- **WHAT TO DO IF YOU SMELL GAS:**
 - Do not try to light any appliance.
 - Do not touch any electrical switch; do not use any phone in your building.
 - Immediately call your gas supplier from a neighbour's phone. Follow the gas supplier's instructions.
 - If you cannot reach your gas supplier, call the fire department.
- Installation and service must be performed by a qualified installer, service agency or the supplier.

This appliance is only for use with the type of gas indicated on the rating plate. This appliance is not convertible for use with other gases, unless a certified kit is used.



GSST8N NATURAL GAS

GSST8P PROPANE

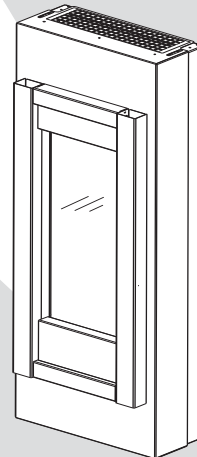

WARNING: FOR OUTDOOR USE ONLY

WARNING

HOT GLASS WILL CAUSE BURNS.

DO NOT TOUCH GLASS UNTIL COOLED.

NEVER ALLOW CHILDREN TO TOUCH GLASS.



Wolf Steel Ltd., 24 Napoleon Rd., Barrie, ON, L4M 0G8 Canada /
103 Miller Drive, Crittenden, Kentucky, USA, 41030
Phone (705)721-1212 • Fax (705)722-6031 • www.napoleonfireplaces.com • ask@napoleonproducts.com

TABLE OF CONTENTS

1.0	INSTALLATION OVERVIEW	3
2.0	INTRODUCTION	4
	2.1 DIMENSIONS	5
	2.2 GENERAL INSTRUCTIONS	5
	2.3 GENERAL INFORMATION	6
	2.4 RATING PLATE INFORMATION	7
3.0	INSTALLATION	8
	3.1 INSTALLATION CLEARANCES	8
	3.2 GAS INSTALLATION	9
	3.3 COMBUSTION AND VENTILATION AIR	9
4.0	FRAMING	10
	4.1 CLEARANCES TO COMBUSTIBLES	10
5.0	FINISHING	11
	5.1 TMCSS MOUNTING CABINET INSTALLATION	11
	5.2 RAIN TABS	12
	5.3 DOOR REMOVAL	13
	5.4 GLASS MEDIA INSTALLATION	14
	5.5 TFSSO FRAME INSTALLATION	15
	5.6 LOGO PLACEMENT	15
	5.7 LK8 LIGHT INSTALLATION (OPTIONAL)	16
6.0	ELECTRICAL INFORMATION	17
7.0	OPERATION	18
8.0	ADJUSTMENTS	19
	8.1 GAS PRESSURE ADJUSTMENT	19
	8.2 VENTURI ADJUSTMENT	19
	8.3 FLAME CHARACTERISTICS	19
9.0	MAINTENANCE	20
	9.1 CARE OF GLASS	20
	9.2 DOOR GLASS REPLACEMENT	21
	9.3 CARE OF STAINLESS STEEL	21
10.0	REPLACEMENTS	22
11.0	TROUBLESHOOTING	24
12.0	WARRANTY	26
13.0	SERVICE HISTORY	27

NOTE: Changes, other than editorial, are denoted by a line in the margin.

1.0 INSTALLATION OVERVIEW

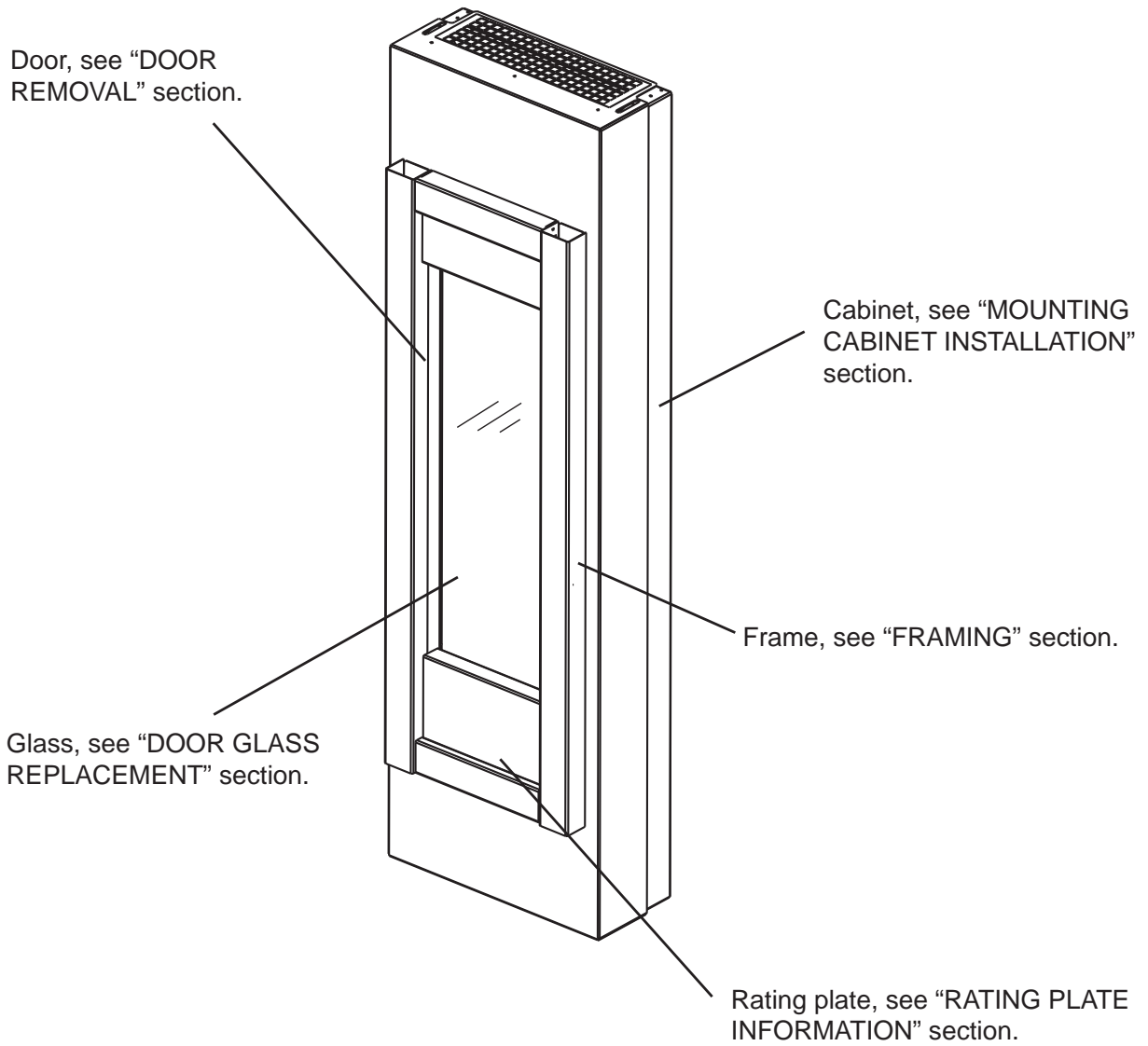

2.0 INTRODUCTION

WARNING

- **THIS APPLIANCE IS HOT WHEN OPERATED AND CAN CAUSE SEVERE BURNS IF CONTACTED.**
- Do not operate appliance before reading and understanding operating instructions. Failure to operate appliance according to operating instructions could cause fire or injury.
- Any changes to this appliance or its controls can be dangerous and is prohibited.
- Risk of burns. The appliance should be turned off and cooled before servicing.
- Do not install damaged, incomplete or substitute components.
- Risk of cuts and abrasions. Wear protective gloves and safety glasses during installation. Sheet metal edges may be sharp.
- Do not burn wood or other materials in this appliance.
- Provide adequate ventilation and combustion air. Provide adequate accessibility clearance for servicing and operating the appliance. Never obstruct the front opening of the appliance.
- If appliance keeps shutting off, have it serviced. Keep burner and control compartment clean.
- Do not allow wind to blow directly into the appliance. Avoid any drafts that alter burner flame patterns.
- Children and adults should be alerted to the hazards of high surface temperature and should stay away to avoid burns or clothing ignition.
- Young children should be carefully supervised when they are in the same area as the appliance. Toddlers, young children and others may be susceptible to accidental contact burns. A physical barrier is recommended if there are at risk individuals in the vicinity of the appliance. To restrict access to an appliance, install an adjustable safety gate to keep toddlers, young children and other at risk individuals away from hot surfaces.
- Clothing or other flammable material should not be placed on or near the appliance.
- Furniture or other objects must be kept a minimum of 4 feet away from the front of the appliance.
- Ensure you have incorporated adequate safety measures to protect infants/toddlers from touching hot surfaces.
- Even after the appliance is off, it will remain hot for an extended period of time.
- Check with your local hearth specialty dealer for safety screens and hearth guards to protect children from hot surfaces. These screens and guards must be fastened to the floor.
- Any safety screen or guard removed for servicing must be replaced prior to operating the appliance.
- It is imperative that the control compartments, burners and circulating blower and its passageway in the appliance and venting system are kept clean. The appliance should be inspected before use and at least annually by a qualified service person. The appliance area must be kept clear and free from combustible materials, gasoline and other flammable vapors and liquids.
- Under no circumstances should this appliance be modified.
- Do not use this appliance if any part has been under water. Immediately call a qualified service technician to inspect the appliance and to replace any part of the control system and any gas control which has been under water.
- Keep the packaging material out of reach of children and dispose of the material in a safe manner. As with all plastic bags, these are not toys and should be kept away from children and infants.
- This appliance must not be installed indoors or within any structure that prevents or inhibits the exhaust gases from dissipating in the outside atmosphere.

3.14A

2.1 DIMENSIONS

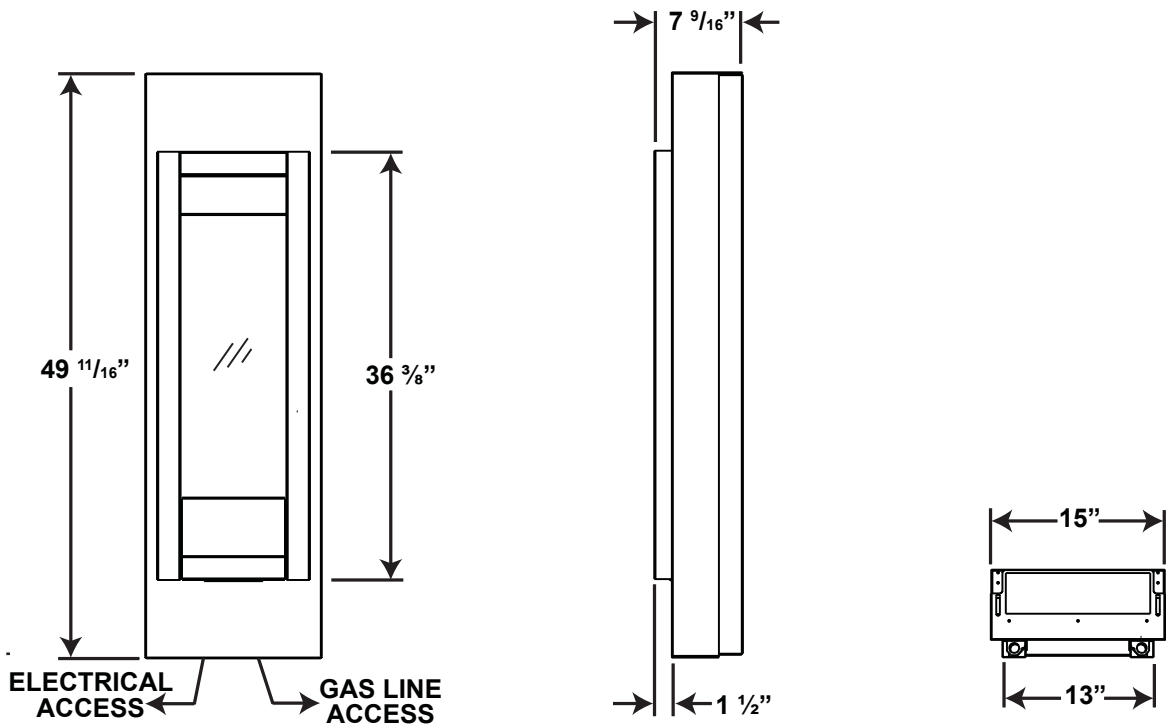

2.2 GENERAL INSTRUCTIONS

! WARNING
ALWAYS LIGHT THE PILOT WHETHER FOR THE FIRST TIME OR IF THE GAS SUPPLY HAS RAN OUT, WITH THE GLASS DOOR OPENED OR REMOVED.
NEVER OBSTRUCT THE FRONT OPENING OF THE APPLIANCE.
OBJECTS PLACED IN FRONT OF THE APPLIANCE MUST BE KEPT A MINIMUM OF 48" FROM THE FRONT FACE OF THE APPLIANCE.
FIRE RISK. EXPLOSION HAZARD.
HIGH PRESSURE WILL DAMAGE VALVE. DISCONNECT GAS SUPPLY PIPING BEFORE PRESSURE TESTING GAS LINE AT TEST PRESSURES ABOVE 1/2 PSIG. CLOSE THE MANUAL SHUT-OFF VALVE BEFORE PRESSURE TESTING GAS LINE AT TEST PRESSURES EQUAL TO OR LESS THAN 1/2 PSIG.
USE ONLY WOLF STEEL APPROVED OPTIONAL ACCESSORIES AND REPLACEMENT PARTS WITH THIS APPLIANCE. USING NON-LISTED ACCESSORIES (BLOWERS, DOORS, LOUVRES, TRIMS, GAS COMPONENTS, VENTING COMPONENTS, ETC.) COULD RESULT IN A SAFETY HAZARD AND WILL VOID THE WARRANTY AND CERTIFICATION.
THE APPLIANCE IS ONLY FOR USE WITH THE TYPE OF GAS INDICATED ON THE RATING PLATE. THIS APPLIANCE IS NOT CONVERTIBLE FOR USE WITH OTHER GASES.

THIS GAS APPLIANCE SHOULD BE INSTALLED AND SERVICED BY A QUALIFIED INSTALLER to conform with local codes. Installation practices vary from region to region and it is important to know the specifics that apply to your area, for example in Massachusetts State:

- The appliance off valve must be a “T” handle gas cock.
- The flexible connector must not be longer than 36 inches.

The installation must conform with local codes or, in absence of local codes, the National Gas and Propane Installation Code CSA B149.1 in Canada, or the National Fuel Gas Code, ANSI Z223.1 / NFPA 54 in the United States.

**NATIONAL
FIREPLACE
INSTITUTE**



CERTIFIED

www.nficerified.org

We suggest that our gas hearth products be installed and serviced by professionals who are certified in the U.S. by the National Fireplace Institute® (NFI) as NFI Gas Specialists

4.3A

2.3 GENERAL INFORMATION

FOR YOUR SATISFACTION, THIS APPLIANCE HAS BEEN TEST-FIRED TO ENSURE ITS OPERATION AND QUALITY!

RATES AND EFFICIENCIES		
	NATURAL GAS	PROPANE GAS
Altitude	0 - 4,500*	0 - 4,500*
Maximum Input	6,000	6,000
Minimum Inlet Gas Supply Pressure	4.5" Water Column	11" Water Column
Maximum Inlet Gas Supply Pressure	7" Water Column	13" Water Column
Manifold Pressure Under Flow Conditions	3.5" Water Column	10" Water Column

When the appliance is installed at elevations above 4,500ft, and in the absence of specific recommendations from the local authority having jurisdiction, the certified high altitude input rating shall be reduced at the rate of 4% for each additional 1,000ft.

This appliance is only for use with the type of gas indicated on the rating plate. This appliance is not convertible for use with other gases, unless a certified kit is used.

Expansion / contraction noises during heating up and cooling down cycles are normal and are to be expected.



Purge all gas lines with the glass door of the appliance removed. Ensure that a continuous gas flow is at the burner before replacing the door.

Objects placed in front of the appliance must be kept a minimum of 48" from the front face of the unit.

Use only authorized accessories designed for and listed with the model.

2.4 RATING PLATE INFORMATION

RATING LABEL LOCATION: THE RATING LABEL IS LOCATED UNDER THE CONTROL PANEL AND IS CHAINED TO THE APPLIANCE. DO NOT REMOVE.

 Intertek <input type="checkbox"/> 9700539 (WSL) <input type="checkbox"/> 4001657 (NGZ) <input type="checkbox"/> 4001658 (NAC) <input type="checkbox"/> 4001659 (WUSA)	CERTIFIED UNDER : CGA CR97-003 (July, 1997) CSA US Req. 4-96, 3rd Ed. OUTDOOR GAS FIREPLACE IF APPLIANCE HAS BEEN SUPPLIED WITH A GAS PRESSURE REGULATOR, IT MUST BE USED. THE GAS SUPPLY MUST BE TURNED OFF AT THE LP-GAS SUPPLY CYLINDER WHEN THIS APPLIANCE IS NOT IN USE. DO NOT STORE OR USE GASOLINE OR OTHER FLAMMABLE VAPORS AND LIQUIDS IN THE VICINITY OF THIS OR ANY OTHER APPLIANCE. IMPROPER INSTALLATION, ADJUSTMENT, ALTERATION, SERVICE OR MAINTENANCE CAN CAUSE INJURY OR PROPERTY DAMAGE. REFER TO THE OWNER'S MANUAL PROVIDED WITH THIS APPLIANCE. FOR ASSISTANCE OR ADDITIONAL INFORMATION, CONSULT A QUALIFIED INSTALLER, SERVICE AGENCY OR GAS SUPPLIER. MUST NOT BE USED FOR COOKING. FOR OUTDOOR USE ONLY. IF STORED INDOORS, DETACH AND LEAVE CYLINDER OUTDOORS.	
	MODEL GSST8N <input type="checkbox"/> (NATURAL GAS) 0-4500FT (0-1370m) 6,000 BTU/h	ALTITUDE INPUT
MANIFOLD PRESSURE: 3.5" WATER COLUMN MINIMUM SUPPLY PRESSURE: 4.5" WATER COLUMN MAXIMUM SUPPLY PRESSURE: 7.0" WATER COLUMN	MANIFOLD PRESSURE: 10" WATER COLUMN MINIMUM SUPPLY PRESSURE: 11" WATER COLUMN MAXIMUM SUPPLY PRESSURE: 13" WATER COLUMN	
WARNING: DO NOT ADD ANY MATERIAL TO THE APPLIANCE, WHICH WILL COME IN CONTACT WITH THE FLAMES, OTHER THAN THAT SUPPLIED BY THE MANUFACTURER WITH THE APPLIANCE.		NOT FOR USE WITH SOLID FUEL. FOR USE WITH GLASS DOOR. CERTIFIED WITH THIS UNIT ONLY.
MINIMUM CLEARANCES TO COMBUSTIBLE MATERIALS TOP 18" BACK 0" SIDES 1" FLOOR 8" TOP, SIDES & BACK AS PER ABOVE. FOR FINISHING MATERIAL, SEE OWNERS MANUAL.		THIS APPLIANCE IS ONLY FOR USE WITH THE TYPE OF GAS INDICATED ON THE RATING PLATE. THIS APPLIANCE IS NOT CONVERTIBLE FOR USE WITH OTHER GASES, UNLESS A CERTIFIED KIT IS USED.
ELECTRICAL RATING: 115v 0.82AMP, 60HZ	WOLF STEEL LTD. 24 NAPOLEON ROAD. BARRIE, ONTARIO L4M 0G8 CANADA	
	SERIAL NUMBER: GSST8	W385-0420 / E

This illustration is for reference only. Refer to the rating plate on the appliance for accurate information.

NOTE: The rating plate must remain with the appliance at all time. It must not be removed.

3.0 INSTALLATION

3.1 INSTALLATION CLEARANCES

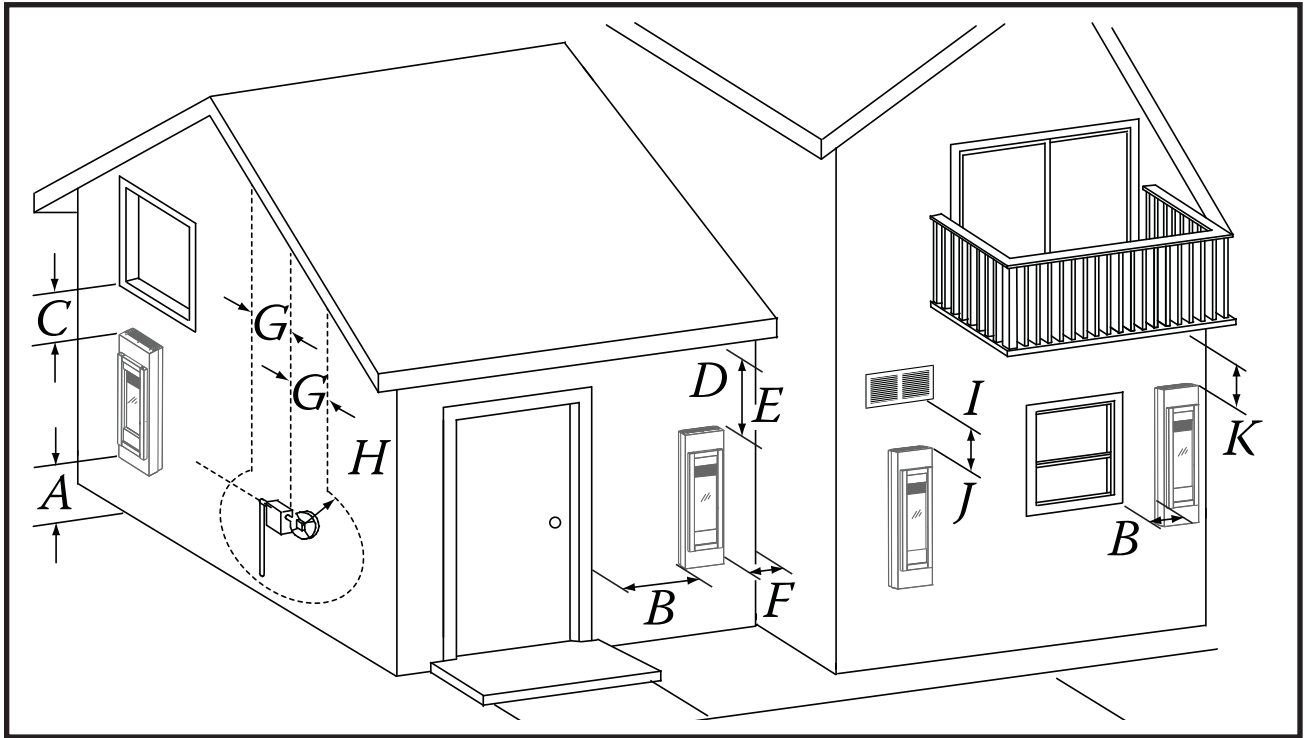

INSTALLATIONS			
	CANADA	U.S.A.	
A	8 INCHES	8 INCHES	Clearance above grade, veranda porch, deck or balcony.
B	12 INCHES	9 INCHES	Clearance to windows or doors that open.
C	12 INCHES*	12 INCHES*	Clearance to permanently closed windows.
D	18 INCHES**	18 INCHES**	Vertical clearance to ventilated soffit.
E	12 INCHES**	12 INCHES**	Vertical clearance to an unventilated soffit.
F	1 INCH	1 INCH	Clearance to an inside combustible corner wall or protruding combustible obstructions. (vent chase, etc.)
G	3 FEET	3 FEET***	Clearance to each side of the centre line extended above the metre/regulator assembly to a maximum vertical distance of 15 ft.
H	3 FEET	3 FEET***	Clearance to a service regulator vent outlet.
I	12 INCHES	9 INCHES	Clearance to a non-mechanical air supply inlet to the building or a combustion air inlet to any other appliance.
J	6 FEET	3 FEET****	Clearance to a mechanical air supply inlet.
K	12 INCHES	12 INCHES***	Clearance under a veranda, porch, deck or balcony.

* Recommended to prevent condensation on windows and thermal breakage.
 ** It is recommended to use a heat shield and to maximize the distance to vinyl clad soffits.
 *** This is a recommended distance. For additional requirements check local codes.
 **** Three feet above if within 10 feet horizontally.

3.2 GAS INSTALLATION

! WARNING

ALL GAS CONNECTIONS MUST BE CONTAINED WITHIN THE APPLIANCE WHEN COMPLETE.

DO NOT USE OPEN FLAME.

- A. The appliance is designed to accept a 1/2" gas supply line. The appliance is equipped with a 1/2" manual shut-off valve.
- B. The access to the gas inlet is located in the bottom of the cabinet.
- C. The shut off valve / flex connector assembly must always be contained within the cabinet.
- D. When flexing any gas line, support the gas valve so that the lines are not kinked.
- E. Check for gas leaks by brushing on a soap and water solution.

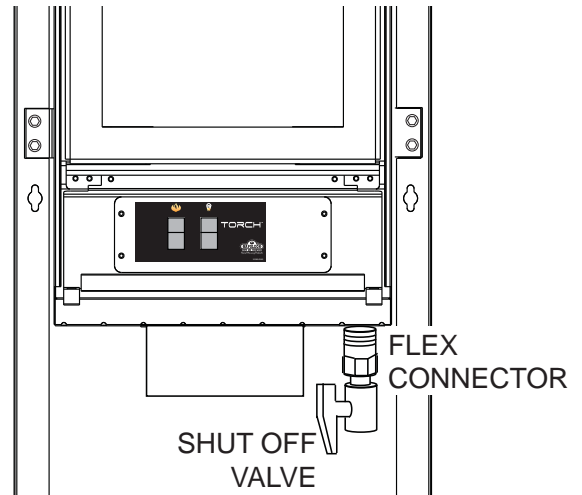

3.3 COMBUSTION AND VENTILATION AIR

! WARNING

ENSURE THE AREA HAS ADEQUATE VENTILATION.

This appliance is intended for installation on an outdoor patio or in your yard. It must never be installed inside the warm air envelope of your structure.

It is highly recommended that this appliance be installed in a "sheltered" area. Direct wind will cause an erratic flame and possible pilot or main burner outage. An erratic flame could also lead to excessive carboning (black soot), this condition is not a safety issue but is visually undesirable.

Typical installation may include covered patio, screened porch, gazebo, or on an outside wall of a house.

4.0 FRAMING

! WARNING

YOUR APPLIANCE IS DESIGNED FOR OUTDOOR APPLICATION ONLY. THE APPLIANCE MUST BE INSTALLED IN THE CABINET PROVIDED. THE CABINET IS DESIGNED TO BE INSTALLED ON FINISHED SURFACES.

THE CABINET MAY BE INSTALLED DIRECTLY ONTO A COMBUSTIBLE SURFACE.

4.1 CLEARANCES TO COMBUSTIBLES

MINIMUM CLEARANCES TO COMBUSTIBLES:

- 18" to top
- 1" to sides
- 8" to bottom
- 0" to rear

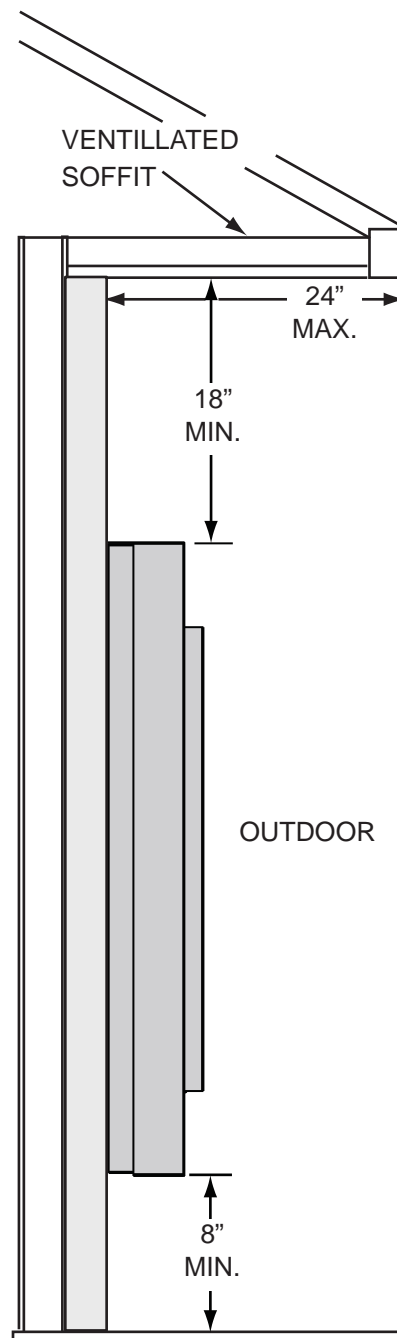

5.0 FINISHING

5.1 TMCSS MOUNTING CABINET INSTALLATION

! WARNING

BEFORE STARTING THE INSTALLATION, REMOVE THE PROTECTIVE LAYER FROM ALL THREE COMPONENTS THAT MAKE UP THE GSST8 (CABINET, FRAME AND TORCH).

NOTE: It is recommended that all fasteners be stainless steel.

- A. Using the installation template (W122-0401) supplied, determine the best mounting location for your new Torch. (Refer to your manual for clearances) Mark all 14 hole centres on the wall (surface) using the template.
- B. Remove the template. Depending on the surface and fasteners, drill the appropriate holes. Hold the Torch up, aligning the mounting brackets to the mounting holes. Secure the Torch to the wall using the appropriate fasteners. **NOTE: The Torch has been designed to have a 1/2" clearance between the rear outer panel and the mounting surface.**

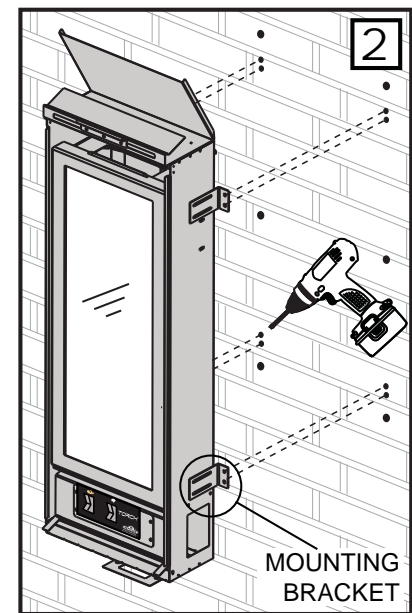
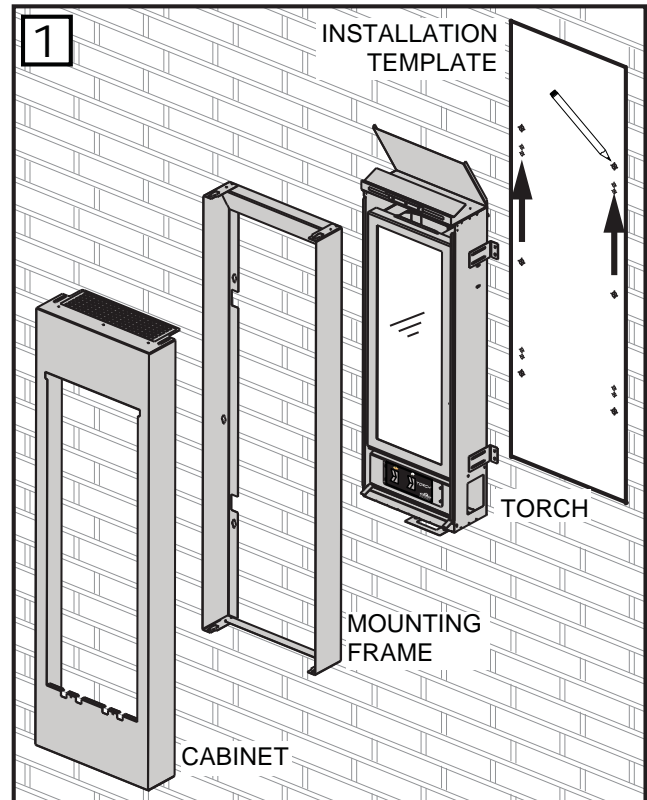

- C. Start the fasteners into each of the six remaining mounting holes. Align the keyholes of the frame to the heads of the fasteners and slide the frame down onto the fasteners. Ensure the frame is plumb and level before tightening the fasteners. **NOTE: It is recommended that the gas and electrical be connected to the appliance at this stage. Both must enter the appliance at the opening created between the bottom of the Torch and the bottom of the mounting frame.**

- D. Slide the front of the cabinet over the mounting frame, ensuring the “mesh” is to the top. Start each of the four screws (supplied) through the slots. Once the cabinet has been adjusted for depth the four screws can be tightened.

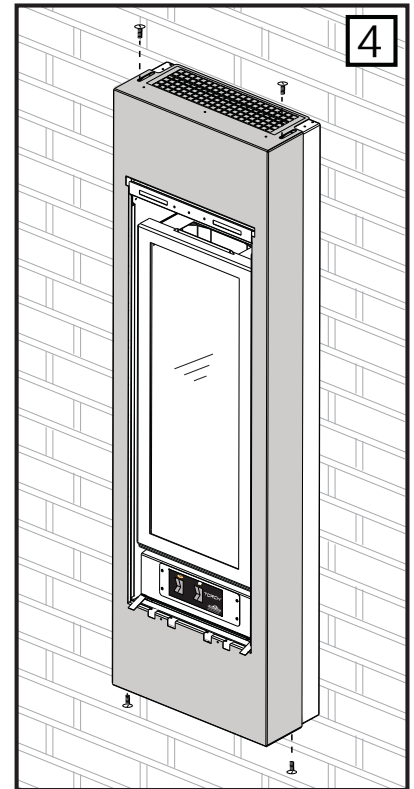
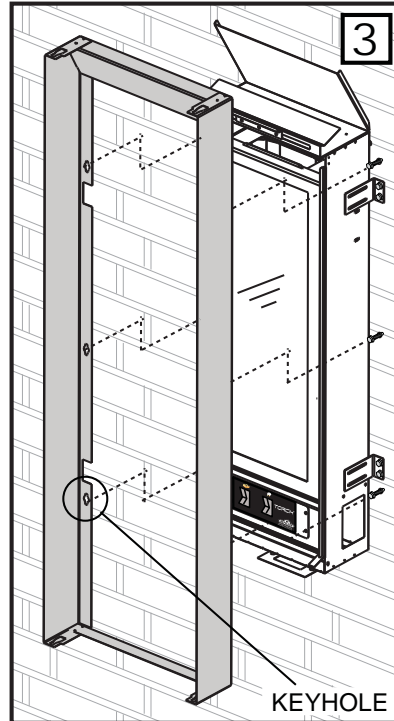

5.2 RAIN TABS

When shipped, the rain tabs should be at a 90° angle. Push the rain tabs down until they are at an approximate 60° angle to assist rain in running off and out of the unit.

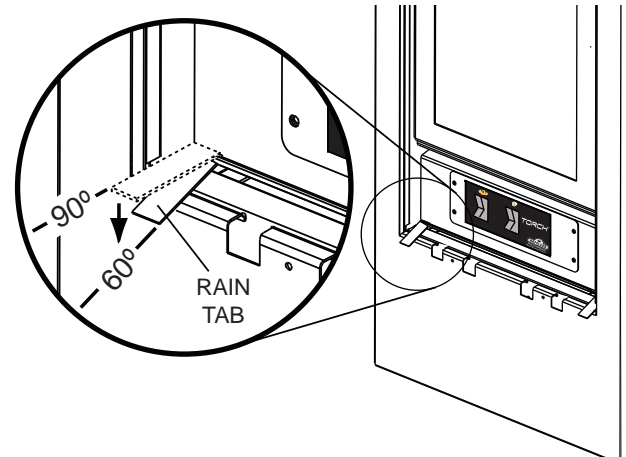

5.3 DOOR REMOVAL

! WARNING

GLASS MAY BE HOT, DO NOT TOUCH GLASS UNTIL COOLED.

THE DOOR LATCHES ARE PART OF A SAFETY SYSTEM AND MUST BE PROPERLY ENGAGED. DO NOT OPERATE THE APPLIANCE WITH LATCHES DISENGAGED.

FACING AND/OR FINISHING MATERIALS MUST NOT INTERFERE WITH AIR FLOW THROUGH AIR OPENINGS, LOUVRES OPENINGS, OPERATION OF LOUVRES OR DOORS OR ACCESS FOR SERVICE. OBSERVE ALL CLEARANCES WHEN APPLYING COMBUSTIBLE MATERIALS.

BEFORE DOOR IS REMOVED TURN THE APPLIANCE OFF AND WAIT UNTIL APPLIANCE IS COOL TO THE TOUCH. DOORS ARE HEAVY AND FRAGILE SO HANDLE WITH CARE.

75.1

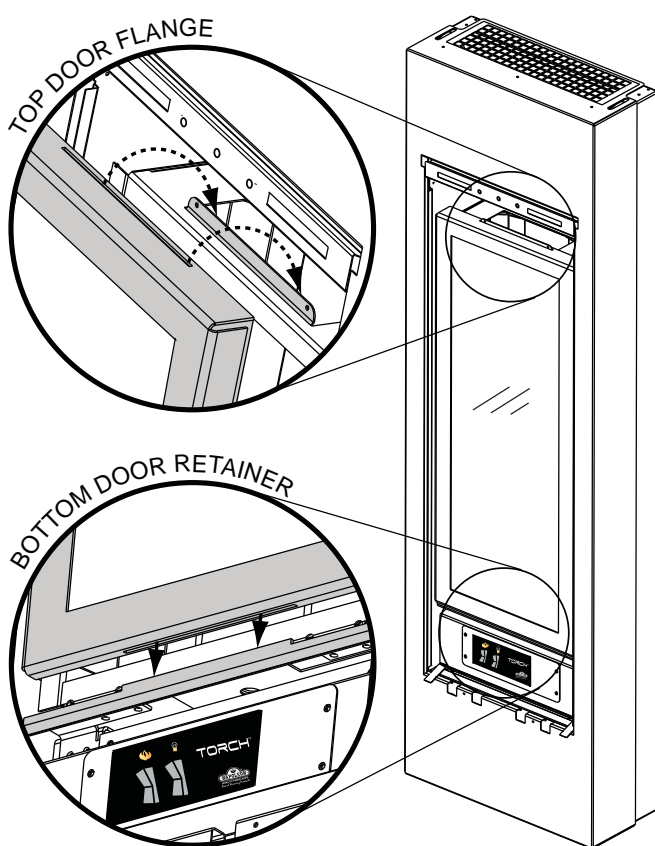

The door is held in place at the bottom by a retainer tab that inserts into a slot in the bottom edge of the door, and at the top with a tab that secures in the same fashion. The door is removed by lifting it off the tabs. When replacing, guide the door over the upper tab first, then over the lower tab.

SECURING THE DOOR IN PLACE

When shipped, the door is secured with two hitch pins along the top edge, replacing them is optional. To secure the door in place use the supplied hitch pins as illustrated.

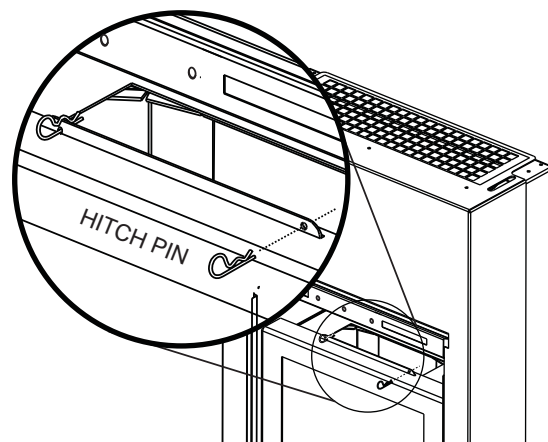

5.4 GLASS MEDIA INSTALLATION

! WARNING

CLEAN THE GLASS MEDIA PRIOR TO INSTALLATION. BEFORE APPLYING THE CLEANED GLASS, ENSURE THAT IT IS DRY.

DO NOT CHANGE OR SUBSTITUTE THE GLASS MEDIA MATERIAL PROVIDED WITH THIS APPLIANCE. IF REPLACING, USE ONLY THE REPLACEMENT GLASS MEDIA AVAILABLE FROM YOUR AUTHORIZED DEALER / DISTRIBUTOR.

Evenly spread the glass media onto the media tray, ensuring no glass media falls into the pilot opening. If this happens, insert a clean bag into your vacuum cleaner and vacuum out the glass media. Replacement glass can be purchased from your local authorized dealer / distributor.

CLEANING GLASS MEDIA

Glass media may have a fine oil residue that needs to be cleaned prior to installation. Clean the glass with mild dish soap, drain, rinse thoroughly and dry before placing around the burner.

74.2A

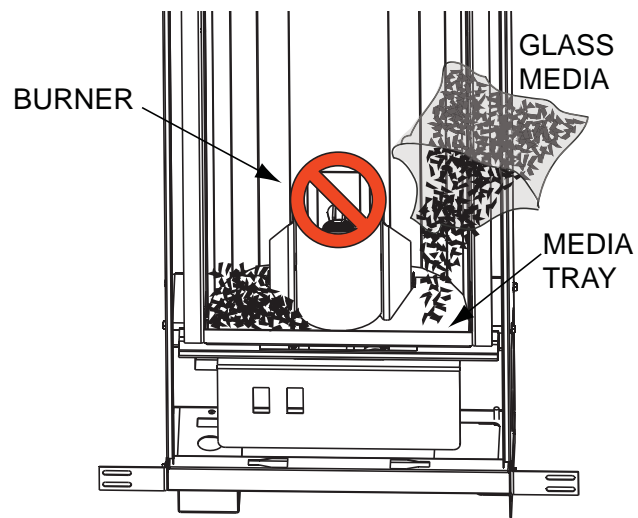

5.5 TFSSO FRAME INSTALLATION

- A. Hang the frame onto the firebox by engaging the top trim bracket into the slot in the top of the frame and the bottom hooks of the frame into the slot in the mounting cabinet.

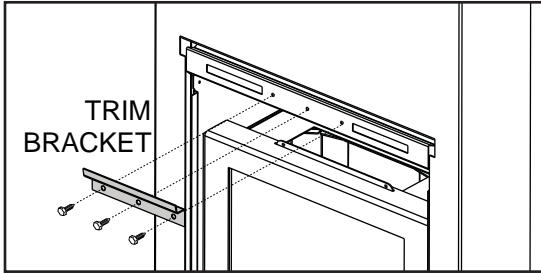

- B. Install the trim bracket supplied in your manual baggie to the firebox using 3 screws.

NOTE: If the frame needs to be secured, use two screws in the holes provided behind the control door.

Insert the door stop chain into the receiving slot in the control door. Then insert the door chain into the receiving slot in the frame so that when fully opened the control door has a clearance of 1/8" to the mounting cabinet.

NOTE: In most cases a count of 15 balls on the chain between receiving slots will be sufficient.

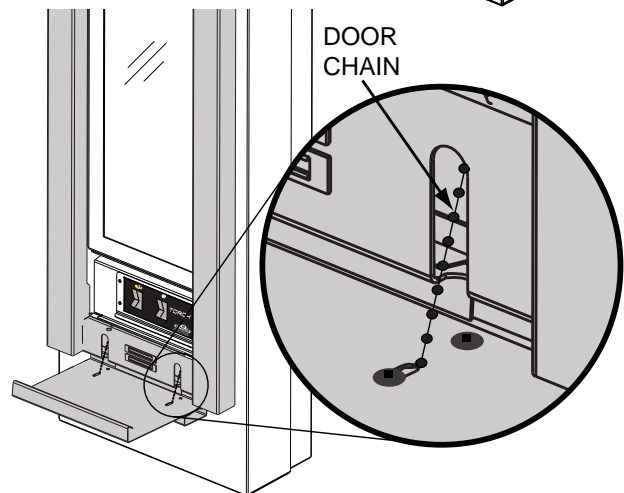
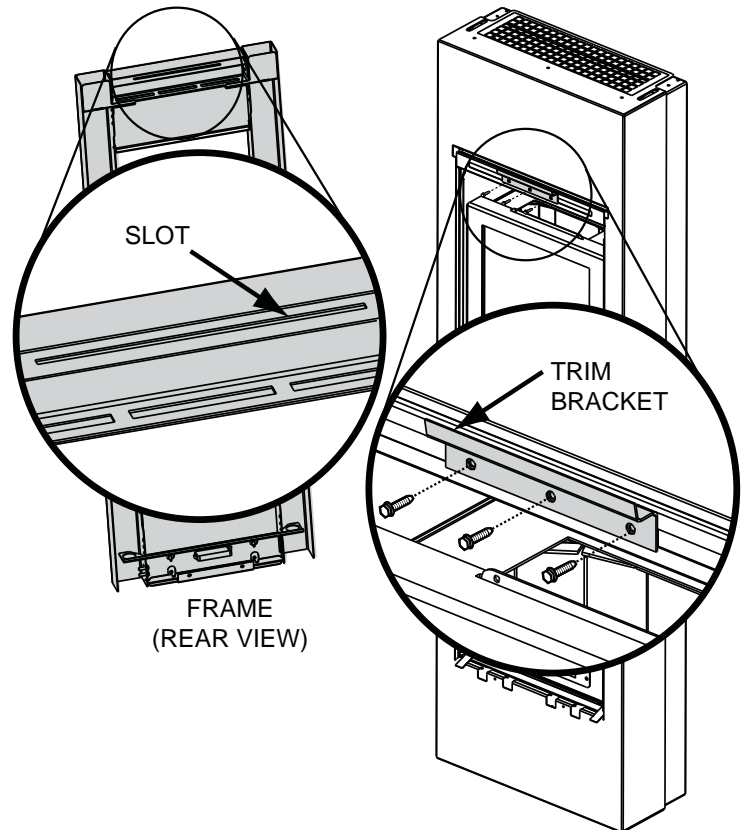

5.6 LOGO PLACEMENT

With the control door closed, affix the logo to the front face of the control door at the bottom left corner.

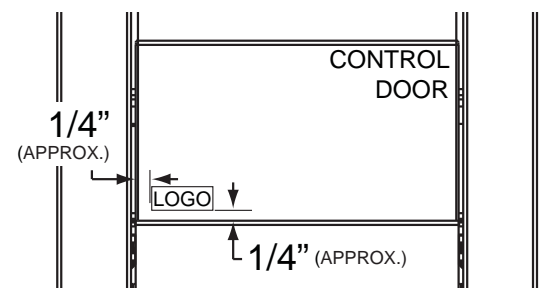

5.7 LK8 LIGHT INSTALLATION (OPTIONAL)

- A. Turn off the electrical and gas supply to the appliance.
- B. Remove the frame from the unit by removing the 2 stainless steel hex head securing screws from the bottom and lifting the frame off of the top trim bracket.
- C. Lay the frame down on its front, being careful not to scratch the finish.
- D. Starting at the top of the frame, take one light assembly and carefully snap it into place in the hole provided. Repeat for each of the light assemblies. The wires on the top 2 light assemblies will need to be fed in behind the heat shields.

NOTE: When installing the light kit be careful not to scratch your fingers on any of the exposed screws in the frame.

- E. Connect the light assemblies to the appropriate flags on the wire harness. The wire harness is labeled (TR) top right, (BR) bottom right (TL) Top left and (BL) bottom left.
- F. Secure the wires into the clips at both sides and the bottom of the frame. Use the extra clips provided to retain any loose wires.
- G. Re-attach frame onto unit.
- H. Open the control panel door, leave the wires connected to the ON/OFF switch and place the transformer into the bottom of the unit. Plug the transformer into the receptacle.
- I. Attach one of the wire leads from the transformer to the lead on the wire harness labeled "TRANS", and the other to the ON/OFF switch. Attach the last lead on the wire harness labeled "SWI" to the ON/OFF switch.
- J. Close the control panel door.
- K. Turn on the gas supply and electrical power.

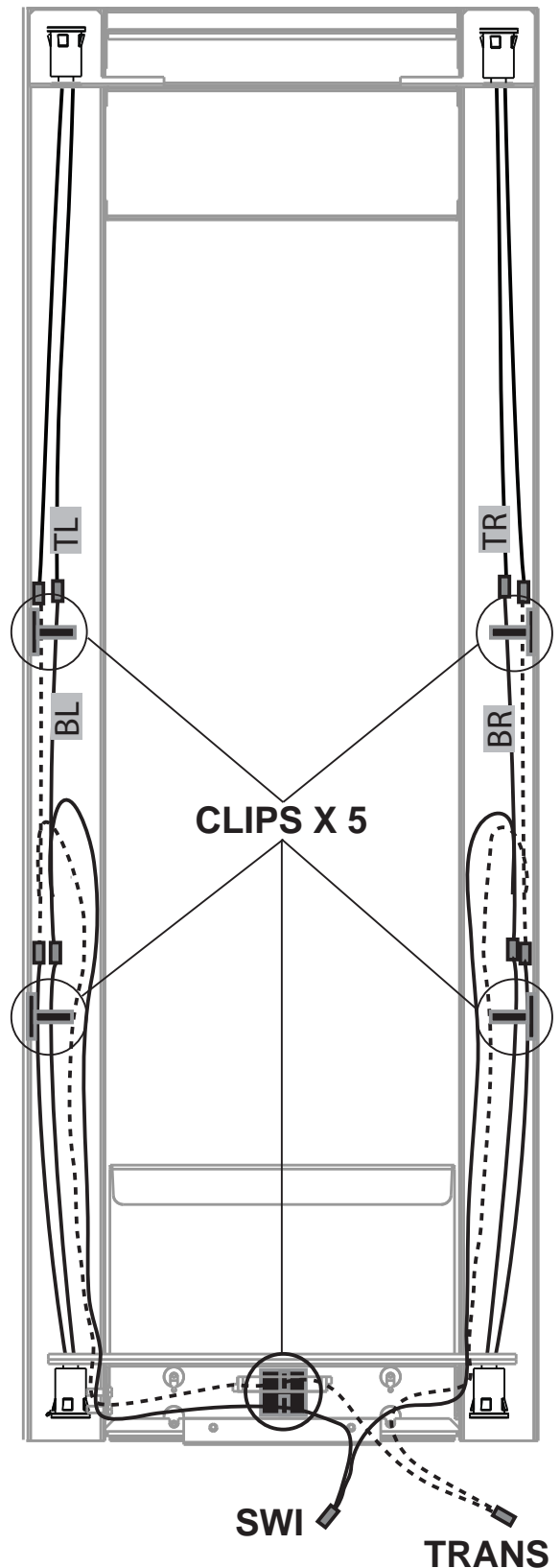

6.0 ELECTRICAL INFORMATION

⚠ WARNING
RISK OF ELECTRIC SHOCK!
CONTROL AND VALVE OPERATE WITH 110V.
DO NOT USE THIS APPLIANCE IF ANY PART HAS BEEN UNDER WATER. CALL A QUALIFIED SERVICE TECHNICIAN IMMEDIATELY TO HAVE THE APPLIANCE INSPECTED FOR DAMAGE TO THE ELECTRICAL CIRCUIT.

It is necessary to hard wire this appliance.

This appliance must be electrically connected and grounded in accordance with local codes. In the absence of local codes, use the current CSA C22.1 Canadian Electrical Code in Canada or the ANSI/NFPA 70-1996 national electrical code in the United States.

NOTE: During assembly, anti-oxidant compound was applied to all electrical connections. If replacing the existing wire harness or disconnecting any connectors, it is highly recommended to re-apply anti-oxidant compound to the relative connections.

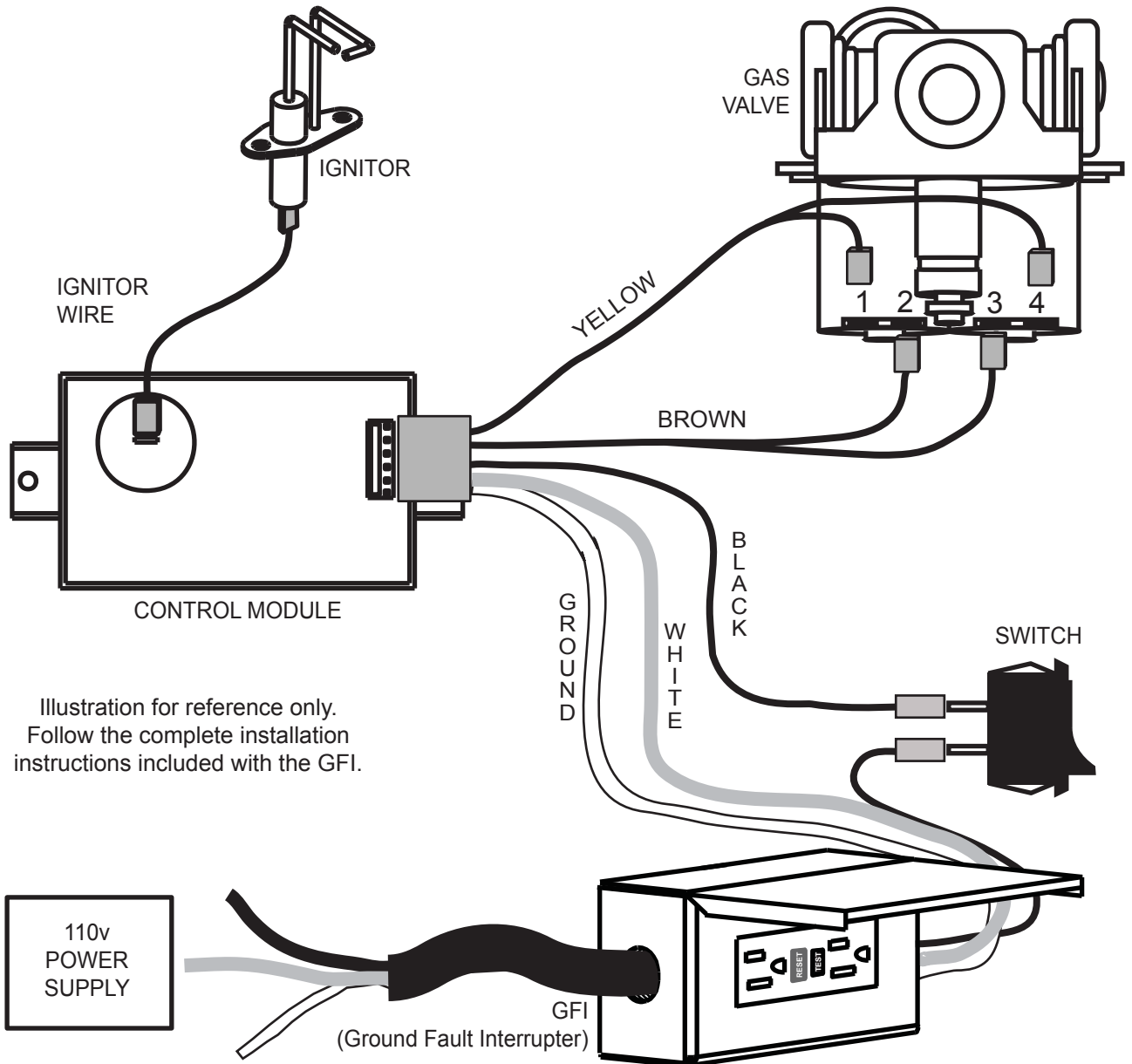

7.0 OPERATION

! WARNING

IF YOU DO NOT FOLLOW THESE INSTRUCTIONS EXACTLY, A FIRE OR EXPLOSION MAY RESULT CAUSING PROPERTY DAMAGE, PERSONAL INJURY OR LOSS OF LIFE.

Ensure that a continuous gas flow is at the burner before installing the door. When lit for the first time, the fireplace will emit an odor for a few hours. This is a normal temporary condition caused by the “burn-in” of paints and lubricants used in the manufacturing process and will not occur again. After extended periods of non-operation such as following a vacation or a warm weather season, the fireplace may emit a slight odor for a few hours. This is caused by dust particles in the heat exchanger burning off. In both cases, open a window to sufficiently ventilate the room.

FOR YOUR SAFETY READ BEFORE LIGHTING:

- A. This fireplace is equipped with an ignition device which automatically lights the pilot. Do not try to light by hand.
- B. Before operating smell all around the fireplace area for gas and next to the floor because some gas is heavier than air and will settle on the floor.
- C. Do not use this fireplace if any part has been under water. Immediately call a qualified service technician to inspect the fireplace and replace any part of the control system and any gas control which has been under water.

WHAT TO DO IF YOU SMELL GAS:

- Turn off all gas to the fireplace.
- Open windows.
- Do not try to light any appliance.
- Do not touch any electric switch; do not use any phone in your building.
- Immediately call your gas supplier from a neighbour’s phone. Follow the gas supplier’s instructions.
- If you cannot reach your gas supplier, call the fire department.

LIGHTING INSTRUCTIONS:

1. Stop! Read the above safety information on this label.
2. Turn off all electrical power to the fireplace.
3. This fireplace is equipped with an ignition device which automatically lights the pilot. Do not try to light the pilot by hand.
4. Open the glass door.
5. Wait five (5) minutes to clear out any gas. If you smell gas including near the floor, STOP! Follow “B” in the above safety information on this label. If you don’t smell gas go to the next step.
6. Close the glass door.
7. Turn on all electric power to the fireplace and re-install batteries into the transmitter.
8. Turn the fireplace switch to the ON position.
9. If fireplace will not operate, follow instructions “To Turn Off Gas” and call your service technician or gas supplier.

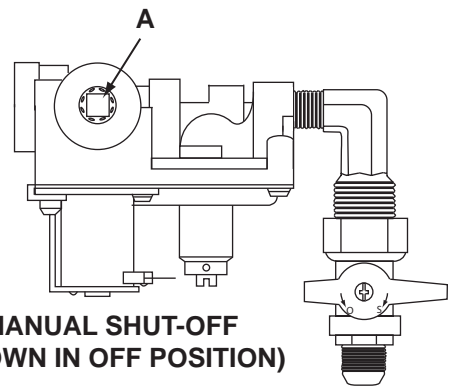

TO TURN OFF GAS:

1. Turn the fireplace switch to the OFF position.
2. Turn off all electrical power to the fireplace if service is to be performed.
3. Turn manual shut-off valve clockwise to off. Do not force.

8.0 ADJUSTMENTS

8.1 GAS PRESSURE ADJUSTMENT

Outlet pressure can be adjusted if not measuring 3.5" W.C. (NG) or 10.0" W.C. (LP).

- A. Pressure can be checked by removing cap (A) using a 3/16 Allen key and replacing it with a 1/8 NPT barb fitting.
- B. Place pressure gauge tube over the fitting.
- C. Pressure can be adjusted by removing cap (B) using a flat screwdriver, and adjusting the nylon plug with the same screw driver. Turning the plug in (clockwise) will increase the pressure.

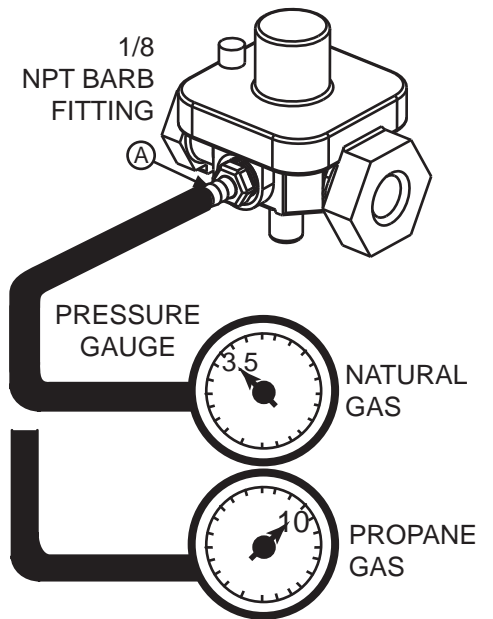
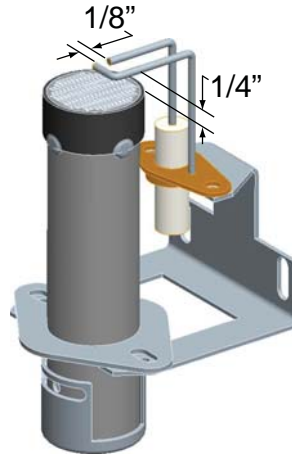

8.2 VENTURI ADJUSTMENT

This model has an air shutter that has been factory set open according to the chart below:

Closing the air shutter will cause a more yellow flame, but can lead to carboning. Opening the air shutter will cause a more blue flame, but can cause flame lifting from the burner ports. The flame may not appear yellow immediately; allow 15 to 30 minutes for the final flame color to be established.

AIR SHUTTER ADJUSTMENT MUST ONLY BE DONE BY A QUALIFIED INSTALLER!

NOTE: It is important that the venturi sits down tight on the orifice.

AIR SHUTTER OPENINGS	
LP	3/16" DIA
NG	1/16" DIA

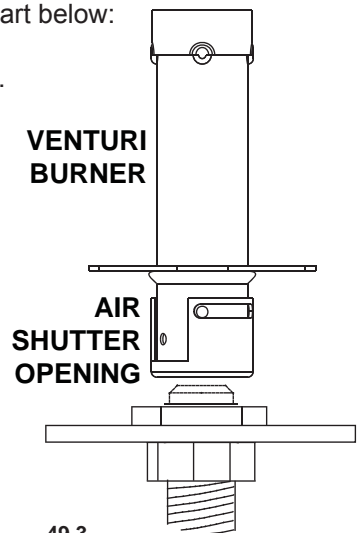

49.3

8.3 FLAME CHARACTERISTICS

It is important to periodically perform a visual check of the burner flame. Compare them to the illustration provided.

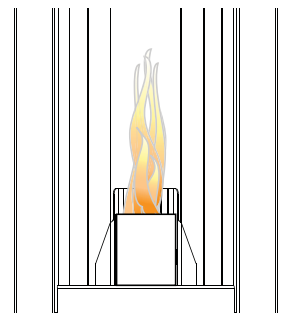

9.0 MAINTENANCE

! WARNING
TURN OFF THE GAS AND ELECTRICAL POWER BEFORE SERVICING THE APPLIANCE.
APPLIANCE MAY BE HOT, DO NOT SERVICE UNTIL APPLIANCE HAS COOLED.
DO NOT USE ABRASIVE CLEANERS.

CAUTION: Label all wires prior to disconnection when servicing controls. Wiring errors can cause improper and dangerous operation. Verify proper operation after servicing. This appliance and its venting system should be inspected before use and at least annually by a qualified service person. The appliance area must be kept clear and free of combustible materials, gasoline or other flammable vapors and liquids. The flow of combustion and ventilation air must not be obstructed.

- A. In order to properly clean the burner and pilot assembly, remove the logs, rocks and/or glass to expose both assemblies.
- B. Keep the control compartment, media, burner, air shutter opening and the area surrounding the logs clean by vacuuming or brushing, at least once a year.
- C. Check to see that all burner ports are burning. Clean out any of the ports which may not be burning or are not burning properly.
- D. Check to see that the pilot flame is large enough to engulf the flame sensor and/or thermocouple / thermopile as well as reaches the burner.
- E. Replace the cleaned logs, rocks or glass. Failure to properly position the media may cause carboning which can be distributed in the surrounding living area.
- F. Check to see that the main burner ignites completely on all openings when turned on. A 5 to 10 second total light-up period is satisfactory. If ignition takes longer, consult your local authorized dealer / distributor.
- G. Check that the gasketing on the sides, top and bottom of the door is not broken or missing. Replace if necessary.
- H. If for any reason the vent air intake system is disassembled, re-install and re-seal per the instructions provided for the initial installation.

 40.1

- Visually inspect the appliance for carbon buildup.
- Using a small whisk or brush, brush off the excess carbon and vacuum up or sweep into the garbage.
- Check the fireplace for corrosion of the main burner base.

9.1 CARE OF GLASS

DO NOT CLEAN GLASS WHEN HOT! DO NOT USE ABRASIVE CLEANERS TO CLEAN GLASS.

Buff lightly with a clean dry soft cloth. Clean both sides of the glass after the first 10 hours of operation with a recommended fireplace glass cleaner. Thereafter clean as required. If the glass is not kept clean permanent discoloration and / or blemishes may result.

! WARNING	
	<p>HOT GLASS WILL CAUSE BURNS.</p> <p>DO NOT TOUCH GLASS UNTIL COOLED.</p> <p>NEVER ALLOW CHILDREN TO TOUCH GLASS.</p>

 5.1

9.2 DOOR GLASS REPLACEMENT

! WARNING
DO NOT USE SUBSTITUTE MATERIALS.
GLASS MAY BE HOT, DO NOT TOUCH GLASS UNTIL COOLED.
CARE MUST BE TAKEN WHEN REMOVING AND DISPOSING OF ANY BROKEN DOOR GLASS OR DAMAGED COMPONENTS. BE SURE TO VACUUM UP ANY BROKEN GLASS FROM INSIDE THE APPLIANCE BEFORE OPERATION.
DO NOT STRIKE, SLAM OR SCRATCH GLASS. DO NOT OPERATE APPLIANCE WITH GLASS REMOVED, CRACKED, BROKEN OR SCRATCHED.

56.2

Having removed the door, lay on a smooth flat surface, face down. There are 4 glass retainers that need to be bent away from the glass to release it from the frame. Do not pry on the glass.

When replacing **DO NOT SUBSTITUTE MATERIAL**, replace the gasket (W562-0008) and the glass (W300-0110). Set new glass into the frame and gently bend tabs into the gasket to secure.

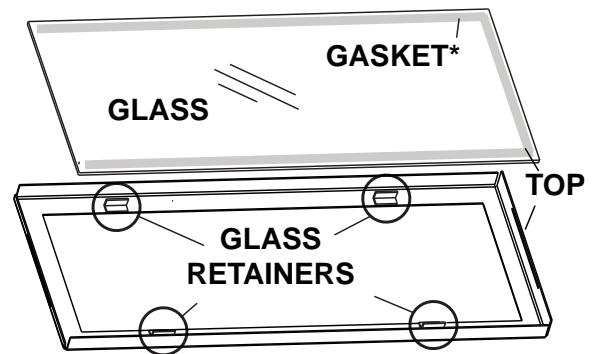

*** When installing the door glass ensure that the gasketed end is placed into the top of the door frame.**

9.3 CARE OF STAINLESS STEEL

Stainless steel tends to oxidize or stain in the presence of chlorides and sulfides, particularly in coastal areas and other harsh environments, such as the warm, highly humid atmosphere around pools and hot tubs. These stains could be perceived as rust, but can be easily removed or prevented. To provide stain prevention and removal, wash all stainless steel surfaces every 3-4 weeks or as often as required with fresh water and/or stainless steel cleaner.

CLEANING THE STAINLESS STEEL SURFACE:

Do not use abrasive cleaners or steel wool on the stainless steel parts. Doing so will scratch the finish. Surfaces should be cleaned with warm soapy water while the metal is still warm to the touch. To clean stainless surfaces, use a stainless steel or non-abrasive cleaner. Always wipe in the direction of the grain. Over time, stainless steel parts discolour when heated, usually to a golden or brown hue. This discolouration is normal and does not affect the performance of the appliance.

81.1

10.0 REPLACEMENTS

Contact your dealer or the factory for questions concerning prices and policies on replacement parts. Normally all parts can be ordered through your Authorized dealer / distributor.

FOR WARRANTY REPLACEMENT PARTS, A PHOTOCOPY OF THE ORIGINAL INVOICE WILL BE REQUIRED TO HONOUR THE CLAIM.

When ordering replacement parts always give the following information:

- Model & Serial Number of appliance
- Installation date of appliance
- Part number
- Description of part
- Finish

*** IDENTIFIES ITEMS WHICH ARE NOT ILLUSTRATED. FOR FURTHER INFORMATION, CONTACT YOUR AUTHORIZED DEALER.**



WARNING

FAILURE TO POSITION THE PARTS IN ACCORDANCE WITH THIS MANUAL OR FAILURE TO USE ONLY PARTS SPECIFICALLY APPROVED WITH THIS APPLIANCE MAY RESULT IN PROPERTY DAMAGE OR PERSONAL INJURY.

41.1

COMPONENTS		
REF NO.	PART NO.	DESCRIPTION
1	W225-0223	DOOR FRAME
2*	W562-0008	DOOR GASKET
3	W010-1959	GLASS C/W GASKET
4*	W300-0110	GLASS
5	W100-0111	BURNER
6	W357-0006	IGNITOR
7	W190-0026	CONTROL, MODULE
8*	W750-0202	WIRE HARNESS
9*	W750-0184	IGNITION CABLE
10	W200-0263	IGNITOR COVER
11	W200-0262	BURNER COVER
12	W725-0052	NATURAL GAS VALVE - 3.5" W.C.
12	W725-0053	PROPANE GAS VALVE - 10.0" W.C.
13*	W455-0085	NATURAL GAS ORIFICE
13*	W455-0086	PROPANE GAS ORIFICE
14	W475-0590	BACK PANEL
15*	W300-0108	ACCENT GLASS (BLACK)
16*	W562-0046	ROPE GASKET, BACK PANEL
17*	W385-0334	NAPOLEON® LOGO
18	W475-0595	CONTROL PANEL
19*	W385-0380	CONTROL PANEL LABEL
20*	W660-0082	OUTDOOR ON/OFF SWITCH
ACCESSORIES		
REF NO.	PART NO.	DESCRIPTION
21	TMCSS	MOUNTING CABINET
22	TFSSO	FRAME KIT
23*	LK8	LIGHT KIT
24*	W573-0002	HIGH TEMPERATURE SEALANT
25*	W573-0007	HIGH TEMPERATURE SEALANT
26*	W175-0270	CONVERSION KIT - NG TO LP
27*	W175-0274	CONVERSION KIT - LP TO NG

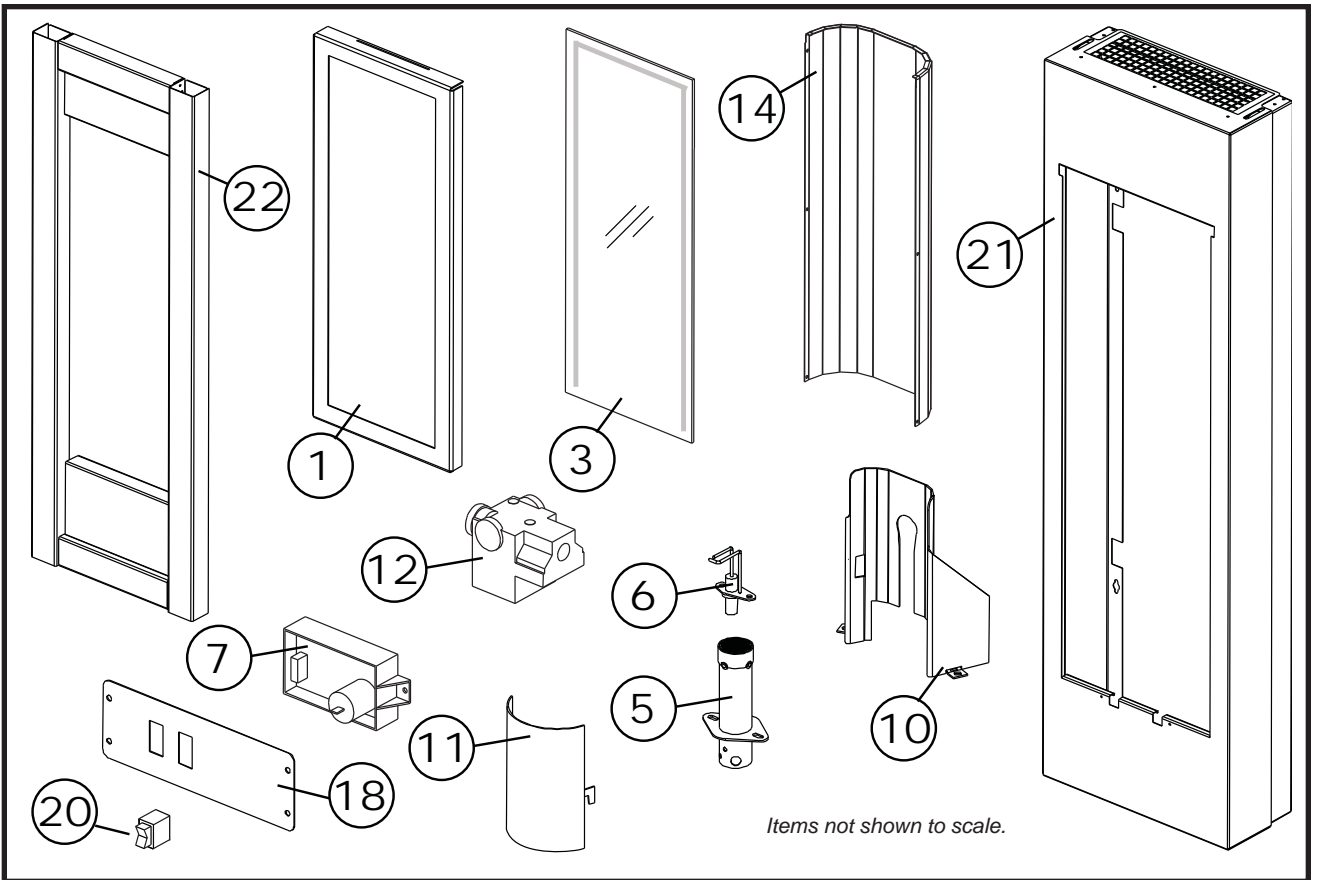

11.0 TROUBLESHOOTING

! WARNING

ALWAYS LIGHT THE PILOT WHETHER FOR THE FIRST TIME OR IF THE GAS SUPPLY HAS RAN OUT, WITH THE GLASS DOOR OPEN OR REMOVED.

TURN OFF THE GAS AND ELECTRICAL POWER BEFORE SERVICING THE APPLIANCE.

APPLIANCE MAY BE HOT, DO NOT SERVICE UNTIL APPLIANCE HAS COOLED.

DO NOT USE ABRASIVE CLEANERS.

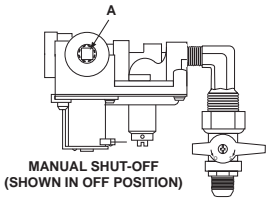
SYMPTOM	PROBLEM	TEST SOLUTION
Electrode sparks, burner ignites, electrode continues to spark for complete 7 seconds, burner shuts down.	Hot and neutral wires are reversed at control module.	- Connect the hot wire to the black wire. Connect the neutral wire to the white wire.
	Sensor / flame not connecting	- Raise electrode / sensor up into flame.
Flame length consistently too large or too small. Carboning occurs.	Unit is over-fired or under-fired.  MANUAL SHUT-OFF (SHOWN IN OFF POSITION)	- Check pressure readings
		- Outlet pressure can be checked by removing cap (A) and replacing it with a 1/8" NPT barb fitting. Next, place pressure gauge tubing over the fitting. Gauge should read 3.5" W.C. for natural gas or 10.0" W.C. for propane. AFTER TAKING PRESSURE READINGS, BE SURE TO REPLACE CAP TO RESEAL. DO NOT OVER-TORQUE.
Carbon is being deposited on glass, logs or combustion chamber surfaces.	Air shutter has become blocked.	- Ensure air shutter opening is free of lint or other obstructions.
	Flame is impinging on the combustion chamber.	- Open air shutter to increase the primary air. - Check the input rate: check the manifold pressure and orifice size as specified by the rating plate values. - Check that the door gasketing is not broken or missing and that the seal is tight.
White / grey film forms.	Sulphur from fuel is being deposited on glass, logs or combustion chamber surfaces.	- Clean the glass with a gas fireplace glass cleaner. DO NOT CLEAN GLASS WHEN HOT. If deposits are not cleaned off regularly, the glass may become permanently marked.
No gas to the main burner; switch is on.	Switch is defective.	- Connect a jumper wire across the wall switch terminals; if main burner lights, replace switch / thermostat.
	Burner orifice is blocked.	- Remove stoppage in orifice.
	Control valve faulty.	- Replace.
	Faulty valve.	- Replace.

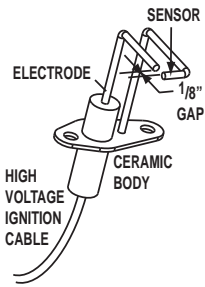
SYMPTOM	PROBLEM	TEST SOLUTION
Burner will not light, ignitor sparks.	No gas at the burner.	- Check that the manual valve is turned on. - Replace the valve.
	Out of propane gas.	- Fill the tank.
Ignitor will not spark.	No spark at ignitor.	- Check the power source. (ie. fuse, circuit breaker)
		- Check that the wire is connected to both the ignitor and the control module.
		- Check that the spark is not jumping to ignitor cover. - Replace the wire if the wire insulation is broken or frayed. - Replace the electrode if the ceramic insulator is cracked or broken.
	Spark gap is incorrect.	- Spark gap should be 0.125" (1/8" approx.) from the electrode tip to the sensor tip.
	Remote wall switch is in "OFF" position; burner comes on.	Wall switch is mounted upside down.
	Remote wall switch is grounding.	- Replace.
	Remote wall switch wire is grounding.	- Check for ground (short); repair ground or replace wire.
	Faulty wire.	- Replace.

42.22_2

12.0 WARRANTY

NAPOLEON® gas appliances are manufactured under the strict Standard of the world recognized ISO 9001 : 2008 Quality Assurance Certificate.

NAPOLEON® products are designed with superior components and materials, assembled by trained craftsmen who take great pride in their work. The burner and valve assembly are leak and test-fired at a quality test station. Once assembled the complete appliance is thoroughly inspected by a qualified technician before packaging to ensure that you, the customer, receives the quality product that you expect from NAPOLEON®.

NAPOLEON® GAS APPLIANCE 5 YEAR LIMITED WARRANTY

All stainless steel components of your new NAPOLEON® gas appliance are warranted against defects for five years.

All parts such as gas valves, logs, gasketing are covered and NAPOLEON® will provide replacement parts free of charge during the first year of the limited warranty.*

Labour related to warranty repair is covered free of charge during the first year. Repair work, however, requires the prior approval of an authorized company official. Labour costs to the account of NAPOLEON® are based on a predetermined rate schedule and any repair work must be done through an authorized NAPOLEON® dealer.

* Construction of models vary. Warranty applies only to components included with your specific appliance.

CONDITIONS AND LIMITATIONS

NAPOLEON® warrants its products against manufacturing defects to the original purchaser only. Registering your warranty is not necessary. Simply provide your proof of purchase along with the model and serial number to make a warranty claim. NAPOLEON® reserves the right to have its representative inspect any product or part thereof prior to honouring any warranty claim. Provided that the purchase was made through an authorized NAPOLEON® dealer your appliance is subject to the following conditions and limitations:

Warranty coverage begins on the date of original installation.

This limited warranty applies only while the unit remains at the site of original installation, and only if the unit is installed in Canada or the United States.

This factory warranty is nontransferable and may not be extended whatsoever by any of our representatives.

Installation must be done in accordance with the installation instructions included with the product and all local and national building and fire codes.

This limited warranty does not cover damages caused by misuse, lack of maintenance, accident, alterations, abuse or neglect and parts installed from other manufacturers will nullify this warranty.

This limited warranty further does not cover any scratches, dents, corrosion or discolouring caused by excessive heat, abrasive and chemical cleaners, mechanical breakage of logs and embers.

In the first year only, this warranty extends to the repair or replacement of warranted parts which are defective in material or workmanship provided that the product has been operated in accordance with the operation instructions and under normal conditions.

After the first year, with respect to this Limited Warranty, NAPOLEON® may, at its discretion, fully discharge all obligations with respect to this warranty by refunding to the original warranted purchaser the wholesale price of any warranted but defective part(s).

After the first year, NAPOLEON® will not be responsible for installation, labour or any other costs or expenses related to the reinstallation of a warranted part, and such expenses are not covered by this warranty.

Notwithstanding any provisions contained in this Limited Warranty, NAPOLEON'S responsibility under this warranty is defined as above and it shall not in any event extend to any incidental, consequential or indirect damages.

This warranty defines the obligations and liability of NAPOLEON® with respect to the NAPOLEON® gas appliance and any other warranties expressed or implied with respect to this product, its components or accessories are excluded.

This limited warranty does not cover damages resulting from the use of components not supplied with the appliance, or the use of fuel other than those specified.

Any damages to appliance due to weather, long periods of dampness, condensation, damaging chemicals or cleaners will not be the responsibility of NAPOLEON®.

The bill of sale or copy will be required together with a serial number and a model number when making any warranty claims from your authorized dealer. The warranty registration card must be returned within fourteen days to register the warranty.

NAPOLEON® reserves the right to have its representative inspect any product or part thereof prior to honouring any warranty claim.

All parts replaced under the Limited warranty policy are subject to a single claim.

All parts replaced under the warranty will be covered for a period of 90 days from the date of their installation.

The manufacturer may require that defective parts or products be returned or that digital pictures be provided to support the claim. Returned products are to be shipped prepaid to the manufacturer for investigation. If a product is found to be defective, the manufacturer will repair or replace such defect.

Before shipping your appliance or defective components, your dealer must obtain an authorization number. Any merchandise shipped without authorization will be refused and returned to sender.

Shipping costs are not covered under this warranty.

Additional service fees may apply if you are seeking warranty service from a dealer.

Labour, travel, diagnostic tests, shipping and other related charges are not covered by this warranty.

ALL SPECIFICATIONS AND DESIGNS ARE SUBJECT TO CHANGE WITHOUT PRIOR NOTICE DUE TO ON-GOING PRODUCT IMPROVEMENTS.
NAPOLEON® IS A REGISTERED TRADEMARK OF WOLF STEEL LTD.

2.9B

13.0 SERVICE HISTORY

Appliance Service History This heater must be serviced annually depending on usage.				
Date	Dealer Name	Service Technician Name	Service Performed	Special Concerns



Other products available from your
Authorized Napoleon® Fireplace Dealer...



Patio Heaters



Fireplace Mantels



HVAC Products



Electric Fireplaces



Outdoor Living Products



Fireplace Accessories

Contact your Authorized Napoleon® dealer or visit napoleonfireplaces.com for more information.