

INSTALLER: LEAVE THIS MANUAL WITH THE APPLIANCE
CONSUMER: RETAIN THIS MANUAL FOR FUTURE REFERENCE



INSTALLATION AND OPERATION INSTRUCTIONS

CERTIFIED UNDER CANADIAN AND AMERICAN NATIONAL STANDARDS: CSA 2.22, ANSI Z21.50 FOR VENTED GAS FIREPLACES.

The
*Dream*TM

BGD90NT
NATURAL GAS

BGD90PT
PROPANE

CERTIFIED FOR CANADA AND UNITED STATES USING ANSI/CSA METHODS.

SAFETY INFORMATION

! WARNING

If the information in these instructions are not followed exactly, a fire or explosion may result causing property damage, personal injury or loss of life.

- Do not store or use gasoline or other flammable vapors and liquids in the vicinity of this or any other appliance.
- **WHAT TO DO IF YOU SMELL GAS:**
 - Do not try to light any appliance.
 - Do not touch any electrical switch; do not use any phone in your building.
 - Immediately call your gas supplier from a neighbour's phone. Follow the gas supplier's instructions.
 - If you cannot reach your gas supplier, call the fire department.
- Installation and service must be performed by a qualified installer, service agency or the supplier.

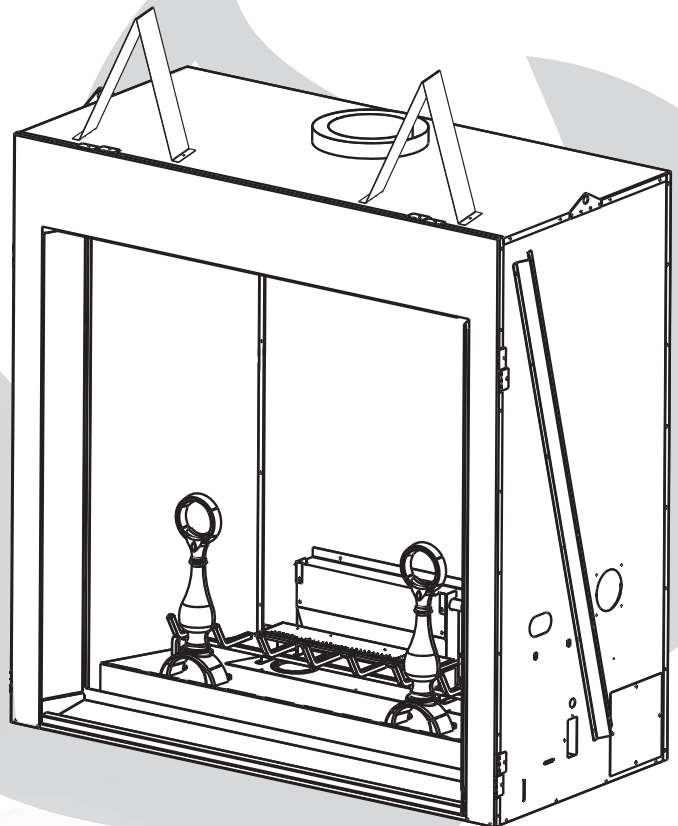

Wolf Steel Ltd., 24 Napoleon Rd., Barrie, ON L4M 4Y8 Canada • (705)721-1212 • fax(705)722-6031
www.napoleonfireplaces.com • ask@napoleon.on.ca

TABLE of CONTENTS

PG2-5	INTRODUCTION				
	Warning				Glowing Embers
	Warranty				Night Light™ Replacement
	Fireplace Dimensions	21		REMOTE AND VALVE ACCESS	
	Installation Overview			Inner Access Panel	
	General Instructions			Remote Receiver Removal	
	General Information			Control Module Removal	
	Care of Glass			Valve Removal	
				"Auto Spark" Battery Removal	
6-10	VENTING		22-25	OPERATION / MAINTENANCE	
	Venting lengths and Air Terminal Locations			General Transmitter Layout	
	Definitions			Fireplace Operation	
	Elbow Vent Length Values			Hand Held Remote Operation	
	Horizontal Termination			Temperature Display	
	Vertical Termination			Room Thermostat	
	Minimum Air Terminal Locations			SMART Thermostat	
11-16	INSTALLATION/FRAMING			Flame Height	
	Wall & Ceiling Protection			Fan Speed	
	Horizontal Installation			Child Proof Function	
	Vertical Installation			Remote Auxiliary Outlet	
	Using Flexible Vent Components			Low Battery / Manual Bypass	
	Horizontal Air Terminal Locations			Power Failure	
	Vertical Air Terminal Locations			Fan Control Module	
	Fireplace Vent Connection			Operating Instructions	
	Gas Installation			Lighting Instructions	
	Mobile Home			Turn off Gas	
	Restricting Vertical Vents				
	Framing		26	ADJUSTMENTS	
	Minimum Clearance to Combustibles			Pilot Burner Adjustment	
	Minimum Mantel and Enclosures Clearances			Flame Characteristics	
16	ELECTRICAL CONNECTION			Venturi Adjustment	
	Hard Wiring Diagram			Maintenance	
	Schematic		27-28	REPLACEMENTS	
17-20	FINISHING			Ordering Replacement Parts	
	Door Removal			Replacement Parts	
	Log Shipping Bracket Removal			Terminal Kits	
	Glass/Door Replacement			Vent Kits	
	Brick Panel Installation			Accessories	
	Andiron Placement		29-30	TROUBLE SHOOTING GUIDE	
	Log Placement		31	SERVICE HISTORY	
	Charcoal Embers		32	NOTES	
	Vermiculite				

INTRODUCTION

! WARNING

- Do not burn wood or other materials in this fireplace.
- Adults and especially children should be alerted to the hazards of high surface temperatures and should stay away to avoid burns or clothing ignition. Supervise young children when they are in the same room as the fireplace.
- Clothing or other flammable material should not be placed on or near the fireplace.
- Due to high temperatures, the fireplace should be located out of traffic and away from furniture and draperies.
- Ensure you have incorporated adequate safety measure to protect infants/toddlers from touching hot surfaces.
- Even after the fireplace is out, the glass and/or screen will remain hot for an extended period of time.
- Check with your local hearth specialty dealer for safety screens and hearth guards to protect children from hot surfaces. These screens and guards must be fastened to the floor.
- Any safety screen or guard removed for servicing must be replaced prior to operating the fireplace.
- It is imperative that the control compartments, burners and circulating blower and its passageway in the fireplace and venting system are kept clean. The fireplace and its venting system should be inspected before use and at least annually by a qualified service person. More frequent cleaning may be required due to excessive lint from carpeting, bedding material, etc. The fireplace area must be kept clear and free from combustible materials, gasoline and other flammable vapours and liquids.
- Under no circumstances should this fireplace be modified.
- This fireplace must not be connected to a chimney flue pipe serving a separate solid fuel burning appliance.
- Do not use this fireplace if any part has been under water. Immediately call a qualified service technician to inspect the fireplace and to replace any part of the control system and any gas control which has been under water.
- Do not operate the fireplace with the glass door removed, cracked or broken. Replacement of the glass should be done by a licensed or qualified service person.
- Do not strike or slam shut the fireplace glass door.
- This fireplace uses and requires a fast acting thermocouple. Replace only with a fast acting thermocouple supplied by Wolf Steel Ltd.
- Pressure relief doors must be kept closed while the fireplace is operating to prevent exhaust fumes containing carbon monoxide, from entering into the home. Temperatures of the exhaust escaping through these openings can also cause the surrounding combustible materials to overheat and catch fire.
- Only doors / optional fronts certified with the unit are to be installed on the appliance.

NAPOLEON® products are manufactured under the strict Standard of the world recognized ISO 9001 : 2000 Quality Assurance Certificate.

NAPOLEON® products are designed with superior components and materials, assembled by trained craftsmen who take great pride in their work. The burner and valve assembly are leak and test-fired at a quality test station. The complete fireplace is thoroughly inspected by a qualified technician before packaging to ensure that you, the customer, receives the quality product that you expect from NAPOLEON®.

NAPOLEON® GAS FIREPLACE PRESIDENT'S LIFETIME LIMITED WARRANTY

The following materials and workmanship in your new NAPOLEON® gas fireplace are warranted against defects for as long as you own the fireplace. This covers: combustion chamber, heat exchanger, stainless steel burner, PHAZER™ logs and embers, ceramic glass (thermal breakage only), gold plated parts against tarnishing, porcelainized enamelled components and aluminum extrusion trims.

Electrical (110V and millivolt) components and wearable parts such as the blower, gas valve, thermal switch, switches, wiring, remote control, ignitor, gasket, and pilot assembly are covered and NAPOLEON® will provide replacement parts free of charge during the first year of the limited warranty. Light bulbs are not covered by this warranty.

Labour related to warranty repair is covered free of charge during the first year. Repair work, however, requires the prior approval of an authorized company official. Labour costs to the account of NAPOLEON® are based on a predetermined rate schedule and any repair work must be done through an authorized NAPOLEON® dealer.

CONDITIONS AND LIMITATIONS

NAPOLEON® warrants its products against manufacturing defects to the original purchaser only -- i.e., the individual or legal entity (registered customer) whose name appears on the warranty registration card filed with NAPOLEON® -- provided that the purchase was made through an authorized NAPOLEON® dealer and is subject to the following conditions and limitations:

This factory warranty is nontransferable and may not be extended whatsoever by any of our representatives.

The gas fireplace must be installed by a licensed, authorized service technician or contractor. Installation must be done in accordance with the installation instructions included with the product and all local and national building and fire codes.

This limited warranty does not cover damages caused by misuse, lack of maintenance, accident, alterations, abuse or neglect and parts installed from other manufacturers will nullify this warranty.

This limited warranty further does not cover any scratches, dents, corrosion or discoloring caused by excessive heat, abrasive and chemical cleaners nor chipping on porcelain enamel parts, mechanical breakage of PHAZER™ logs and embers, nor any venting components used in the installation of the fireplace.

NAPOLEON® warrants its stainless steel burners against defects in workmanship and material for life, subject to the following conditions: During the first 10 years NAPOLEON® will replace or repair the defective parts at our option free of charge. From 10 years to life, NAPOLEON® will provide replacement burners at 50% of the current retail price.

In the first year only, this warranty extends to the repair or replacement of warranted parts which are defective in material or workmanship provided that the product has been operated in accordance with the operation instructions and under normal conditions.

After the first year, with respect to this President's Limited Lifetime Warranty, NAPOLEON® may, at its discretion, fully discharge all obligations with respect to this warranty by refunding to the original warranted purchaser the wholesale price of any warranted but defective part(s).

After the first year, NAPOLEON® will not be responsible for installation, labour or any other costs or expenses related to the reinstallation of a warranted part, and such expenses are not covered by this warranty.

Notwithstanding any provisions contained in this President's Limited Lifetime Warranty, NAPOLEON'S responsibility under this warranty is defined as above and it shall not in any event extend to any incidental, consequential or indirect damages.

This warranty defines the obligations and liability of NAPOLEON® with respect to the NAPOLEON® gas fireplace and any other warranties expressed or implied with respect to this product, its components or accessories are excluded.

NAPOLEON® neither assumes, nor authorizes any third party to assume, on its behalf, any other liabilities with respect to the sale of this product. NAPOLEON® will not be responsible for: over-firing, downdrafts, spillage caused by environmental conditions such as rooftops, buildings, nearby trees, hills, mountains, inadequate vents or ventilation, excessive venting configurations, insufficient makeup air, or negative air pressures which may or may not be caused by mechanical systems such as exhaust fans, furnaces, clothes dryers, etc.

Any damages to fireplace, combustion chamber, heat exchanger, brass trim or other component due to water, weather damage, long periods of dampness, condensation, damaging chemicals or cleaners will not be the responsibility of NAPOLEON®.

The bill of sale or copy will be required together with a serial number and a model number when making any warranty claims from your authorized dealer. The warranty registration card must be returned within fourteen days to register the warranty.

NAPOLEON® reserves the right to have its representative inspect any product or part thereof prior to honouring any warranty claim.

FIREPLACE DIMENSIONS

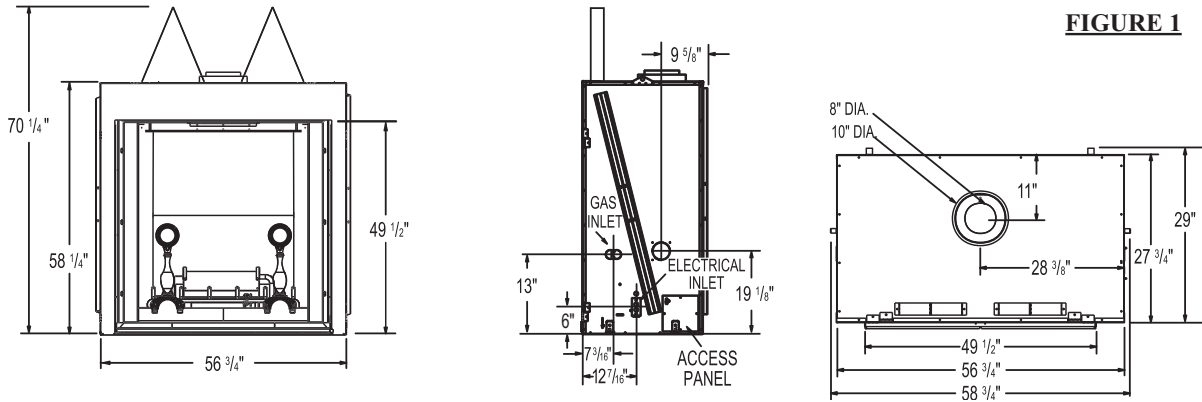
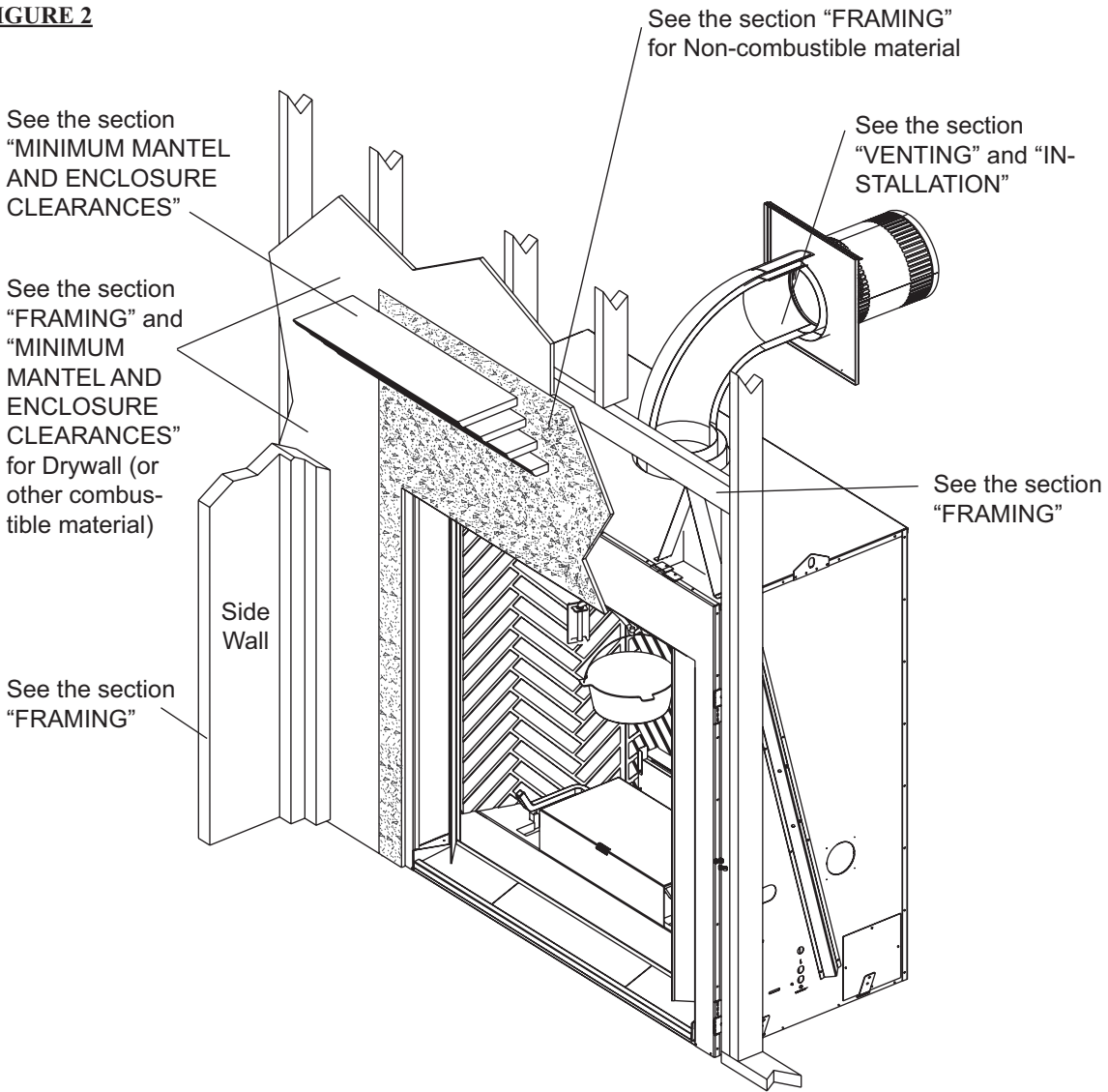

FIGURE 1

INSTALLATION OVERVIEW

FIGURE 2



GENERAL INSTRUCTIONS

This gas fireplace should be installed and serviced by a qualified installer to conform with local codes. Installation practices vary from region to region and it is important to know the specifics that apply to your area, for example: in Massachusetts State:

- The fireplace damper must be removed or welded in the open position prior to installation of a fireplace insert or gas log.
- The appliance off valve must be a "T" handle gas cock.
- The flexible connector must not be longer than 36 inches.
- A Carbon Monoxide detector is required in all rooms containing gas fired appliances.
- The appliance is not approved for installation in a bedroom or bathroom unless the unit is a direct vent sealed combustion product.
- **WARNING:** This product must be installed by a licensed plumber or gas fitter when installed within the commonwealth of Massachusetts.

In absence of local codes, install to the current CAN/CGA -B149 Installation Code in Canada or to the National Fuel Gas Code, ANSI Z223.1, and NFPA 54 in the United States. Suitable for mobile home installation if installed in accordance with the current standard CAN/CSA Z240MH Series, for gas equipped mobile homes, in Canada or ANSI Z223.1 and NFPA 54 in the United States.

The fireplace and its individual shutoff valve must be disconnected from the gas supply piping system during any pressure testing of that system at test pressures in excess of 1/2 psig (3.5 kPa). The fireplace must be isolated from the gas supply piping system by closing its individual manual shutoff valve during any pressure testing of the gas supply piping system at test pressures equal to or less than 1/2 psig (3.5 kPa).

When the fireplace is installed directly on carpeting, vinyl tile or other combustible material other than wood flooring, the fireplace shall be installed on a metal or wood panel extending the full width and depth.

The optional heat circulating blower is supplied with a cord. If installed, the junction box must be electrically connected and grounded in accordance with local codes. In the absence of local codes, use the current CSA C22.1 Canadian electrical code in Canada or the ANSI/NFPA 70 national electrical code in the United States.

Purge all gas lines with the glass door of the fireplace open. Assure that a continuous gas flow is at the burner before closing the door. Under extreme vent configurations, allow several minutes (5-15) for the flame to stabilize after ignition.

Provide adequate ventilation and combustion air. Provide adequate accessibility clearance for servicing and operating the fireplace. Never obstruct the front opening of the fireplace.

Objects placed in front of the fireplace must be kept a minimum of 48" from the front face of the unit.

It is recommended that the walls of the fireplace enclosure be finished. This would ensure that clearance to combustibles is maintained with the cavity.

Non-combustible finishing material (i.e. cement board, brick, stone, tile) must be used to finish the front of the unit.

GENERAL INFORMATION

FOR YOUR SATISFACTION, THIS FIREPLACE HAS BEEN TEST-FIRED TO ASSURE ITS OPERATION AND QUALITY! Maximum input is 50,000 BTU/hr for both natural gas and propane. When the fireplace is installed at elevations above 4,500ft, and in the absence of specific recommendations from the local authority having jurisdiction, the certified high altitude input rating shall be reduced at the rate of 4% for each additional 1,000ft. Maximum output for natural gas is 33,540 BTU/hr at an efficiency of 63%; and 34,000 BTU/hr for propane at an efficiency of 61%. Minimum inlet gas supply pressure is 4.5" water column for natural gas and 11" water column for propane. Maximum inlet gas pressure is 7" water column for natural gas and 13" water column for propane. Manifold pressure under flow conditions is 3.5 inches water column for natural gas and 10 inches water column for propane.

This fireplace is approved for bathroom, bedroom and bed-sitting room installations and is certified for mobile home installation. The natural gas model can only be installed in a mobile home that is permanently positioned on its site and fueled with natural gas.

This fireplace is only for use with the type of gas indicated on the rating plate. This fireplace is not convertible for use with other gases, unless a certified kit is used. No external electricity (110 volts or 24 volts) is required for the gas system operation. Expansion / contraction noises during heating up and cooling down cycles are normal and are to be expected. Change in flame appearance from "HI" to "LO" is more evident in natural gas than in propane.



We suggest that our gas hearth products be installed and serviced by professionals who are certified in the U.S. by the National Fireplace Institute® (NFI) as NFI Gas Specialists.

CARE OF GLASS

Do not use abrasive cleaners to clean plated parts. Buff lightly with a clean dry cloth. Refer to "REPLACEMENT PARTS" to find out what this product is equipped with and the thickness of the glass.

Use only replacement glass available from your Authorized dealer. **DO NOT SUBSTITUTE MATERIALS.** Clean the glass after the first 10 hours of operation with a recommended gas fireplace glass cleaner. Thereafter clean as required.

DO NOT CLEAN GLASS WHEN HOT! If the glass is not kept clean permanent discoloration and / or blemishes may result.

⚠ WARNING



HOT GLASS WILL CAUSE BURNS.
DO NOT TOUCH GLASS UNTIL COOLED.
NEVER ALLOW CHILDREN TO TOUCH GLASS.

VENTING

VENTING LENGTHS AND AIR TERMINAL LOCATIONS

For safe and proper operation of the fireplace follow the venting instructions exactly.

Deviation from the minimum vertical vent length can create difficulty in burner start-up and/or carboning.

Provide a means for visually checking the vent connection to the fireplace after the fireplace is installed.

Vent lengths that pass through unheated spaces (attics, garages, crawl spaces) should be insulated with the insulation wrapped in a protective sleeve to minimize condensation.

When using Wolf Steel Ltd. venting components, use only approved Wolf Steel Ltd. flexible vent components with the following termination kits: WALL TERMINAL KIT **GD622**, or 1/12 TO 7/12 PITCH ROOF TERMINAL KIT **GD610**, 8/12 TO 12/12 ROOF TERMINAL KIT **GD611**, FLAT ROOF TERMINAL KIT **GD612**. With flexible venting, in conjunction with the various terminations, use either the 5 foot vent kit **GD620** or the 10 foot vent kit **GD630**. These vent kits allow for either horizontal or vertical venting of the fireplace.

The maximum allowable vertical vent length is 40 feet. The maximum number of allowable 8" vent connections is **three horizontally or vertically** (excluding the fireplace and the air terminal connections).

For optimum flame appearance and fireplace performance, keep the vent length and number of elbows to a minimum. The air terminal must remain unobstructed at all times. Examine the air terminal at least once a year to verify that it is unobstructed and undamaged.

When venting, the horizontal run must be kept to a **maximum of 20 feet**. If a 20 foot horizontal run is required, the fireplace must have a **minimum vertical rise immediately off the fireplace of 57"**. When terminating vertically, the vertical rise is a minimum 3 feet and a maximum 40 feet above the fireplace. FIGURES 3a-b.

FIGURE 3a

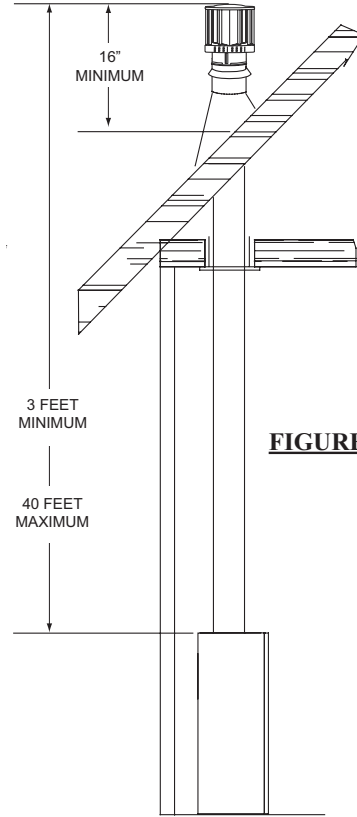
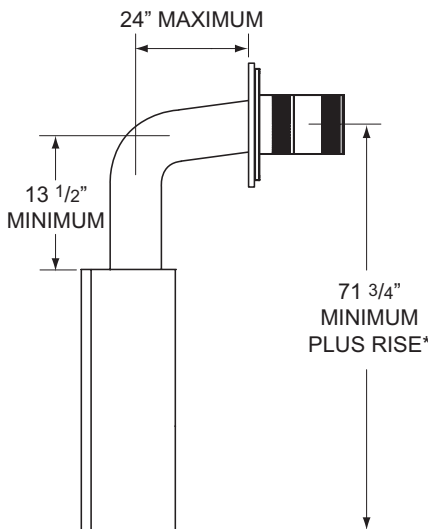

FIGURE 3b

* For optimum performance, it is recommended that all horizontal runs have a minimum 1/4" rise per foot.

Provide a means for visually checking the vent connection to the fireplace after the fireplace is installed.

Do not allow the inside liner to bunch up on horizontal or vertical runs and elbows. Keep it pulled tight. A 3/4" air gap between the inner and outer liner all around is required for safe operation. Use a firestop when penetrating interior walls, floor or ceiling.

For safe and proper operation of the fireplace follow the venting instruction exactly.

If vertical rises greater than 57" are necessary, the increased rise must be deducted from the horizontal run.

HORIZONTAL VENT SECTIONS: A minimum clearance of 2" all around the vent pipe on all horizontal runs to combustibles is required except for clearances in fireplace enclosures**. Use firestop spacer assembly W010-1797 (supplied).

VERTICAL VENT SECTIONS: A minimum of 1" all around the vent pipe on all vertical runs to combustibles is required except for clearances in fireplace enclosures**. Use firestop spacer W615-0075 (not supplied).

** Horizontal and vertical sections require 5" and 9" clearance from combustibles, respectively. See minimum enclosure clearances section.

DEFINITIONS

for the following symbols used in the venting calculations and examples are:

- > - greater than
- ≥ - equal to or greater than
- < - less than
- ≤ - equal to or less than
- H_T** - total of both horizontal vent lengths (**H_R**) and offsets (**H_O**) in feet
- H_R** - combined horizontal vent lengths in feet
- H_O** - offset factor: .03(total degrees of offset - 90°*) in feet
- V_T** - combined vertical vent lengths in feet

ELBOW VENT LENGTH VALUES

	feet	inches
1°	0.03	0.5
15°	0.45	6.0
30°	0.9	11.0
45°	1.35	16.0
90°*	2.7	32.0

* the first 90° offset has a zero value and is shown in the formula as -90°

HORIZONTAL TERMINATION

When (**H_T**) < (**V_T**)
Simple venting configuration (only one 90° elbow)

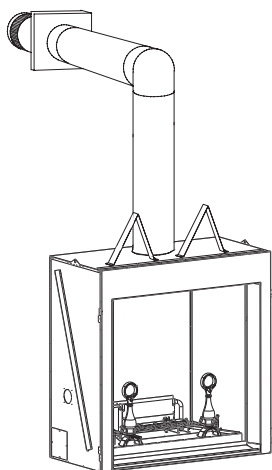

FIGURE 4

See graph to determine the required vertical rise **V_T** for the required horizontal run **H_T**.

For vent configurations requiring more than one 90° elbow, the following formulas apply:

- Formula 1: H_T ≤ V_T**
- Formula 2: H_T + V_T ≤ 40 feet**

Example 1:

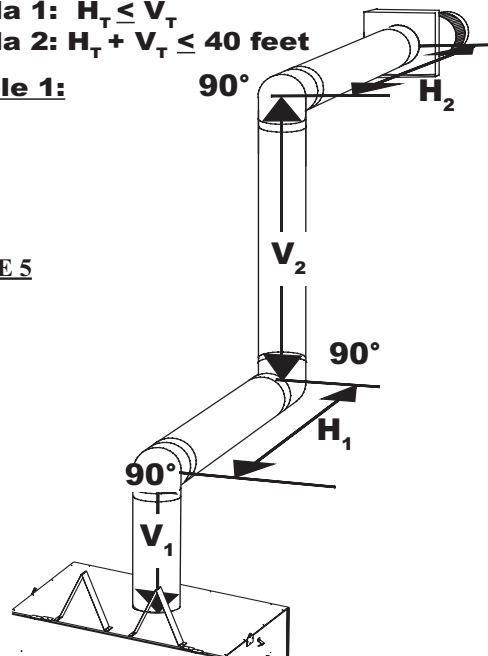
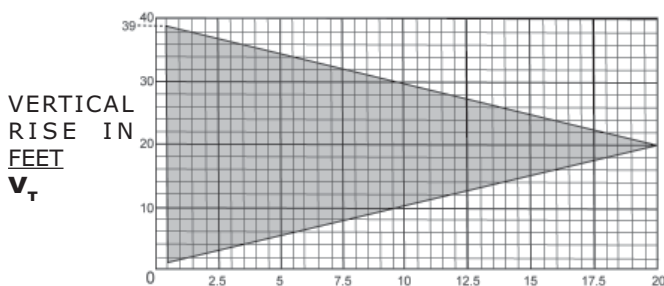

FIGURE 5



HORIZONTAL VENT RUN PLUS OFFSET IN FEET **H_T**
The shaded area within the lines represents acceptable values for H_T and V_T.

$$\begin{aligned}
 V_1 &= 3 \text{ ft} \\
 V_2 &= 8 \text{ ft} \\
 V_T &= V_1 + V_2 = 3 + 8 = 11 \text{ ft} \\
 H_1 &= 2.5 \text{ ft} \\
 H_2 &= 2 \text{ ft} \\
 H_R &= H_1 + H_2 = 2.5 + 2 = 4.5 \text{ ft} \\
 H_O &= .03(\text{three } 90^\circ \text{ elbows} - 90^\circ) = .03(270^\circ - 90^\circ) = 5.4 \text{ ft} \\
 H_T &= H_R + H_O = 4.5 + 5.4 = 9.9 \text{ ft}
 \end{aligned}$$

$$H_T + V_T = 9.9 + 11 = 20.9 \text{ ft}$$

Formula 1: **H_T ≤ V_T**
9.9 ≤ 11

Formula 2: **H_T + V_T ≤ 40 feet**
20.9 ≤ 40

Since both formulas are met, this vent configuration is acceptable.

HORIZONTAL TERMINATION

when $(H_T) > (V_T)$
 Simple venting configuration (only one 90° elbow)

FIGURE 6

See graph to determine the required vertical rise V_T for the required horizontal run H_T .

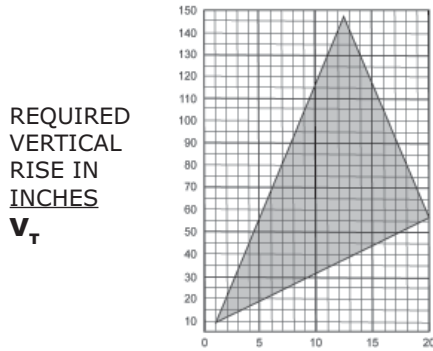
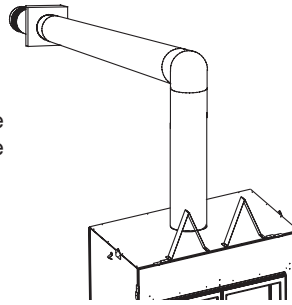

HORIZONTAL VENT RUN PLUS OFFSET IN FEET H_T
 The shaded area within the lines represents acceptable values for H_T and V_T .

For vent configurations requiring more than one 90° elbow the following formulas apply:

Formula 1: $H_T \leq 4.2 V_T$

Formula 2: $H_T + V_T \leq 24.75$ feet

Example 3:

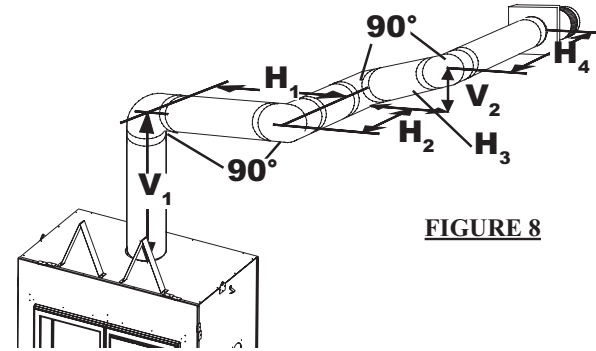

FIGURE 8

$$\begin{aligned}
 V_1 &= 4 \text{ ft} \\
 V_2 &= 1.5 \text{ ft} \\
 V_T &= V_1 + V_2 = 4 + 1.5 = 5.5 \text{ ft} \\
 H_1 &= 2 \text{ ft} \\
 H_2 &= 1 \text{ ft} \\
 H_3 &= 1 \text{ ft} \\
 H_4 &= 1.5 \text{ ft} \\
 H_R &= H_1 + H_2 + H_3 + H_4 = 2 + 1 + 1 + 1.5 = 5.5 \text{ ft} \\
 H_O &= .03(\text{four } 90^\circ \text{ elbows} - 90^\circ) = .03(360^\circ - 90^\circ) = 8.1 \text{ ft} \\
 H_T + H_O &= 5.5 + 8.1 = 13.6 \text{ ft} \\
 H_T + V_T &= 13.6 + 5.5 = 19.1 \text{ ft}
 \end{aligned}$$

Formula 1: $H_T \leq 4.2 V_T$
 $4.2 V_T = 4.2 \times 5.5 = 23.1$

$$13.6 \leq 23.1$$

Formula 2: $H_T + V_T \leq 24.75$ feet
 $19.1 \leq 24.75$

Since both formulas are met, this vent configuration is acceptable.

Example 2:

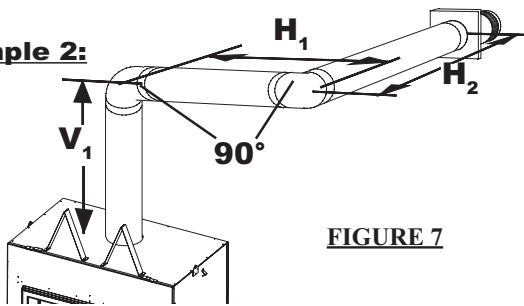

FIGURE 7

$$\begin{aligned}
 V_1 &= V_T = 6 \text{ ft} \\
 H_1 &= 3 \text{ ft} \\
 H_2 &= 5 \text{ ft} \\
 H_R &= H_1 + H_2 = 3 + 5 = 8 \text{ ft} \\
 H_O &= .03(\text{two } 90^\circ \text{ elbows} - 90^\circ) = .03(180^\circ - 90^\circ) = 2.7 \text{ ft} \\
 H_T &= H_R + H_O = 8 + 2.7 = 10.7 \text{ ft} \\
 H_T + V_T &= 10.7 + 6 = 16.7
 \end{aligned}$$

Formula 1: $H_T \leq 4.2 V_T$
 $4.2 V_T = 4.2 \times 6 = 25.2$

$$10.7 \leq 25.2$$

Formula 2: $H_T + V_T \leq 24.75$ feet
 $16.7 \leq 24.75$

Since both formulas are met, this vent configuration is acceptable.

VERTICAL TERMINATION

when $(H_T) \leq (V_T)$

FIGURE 9

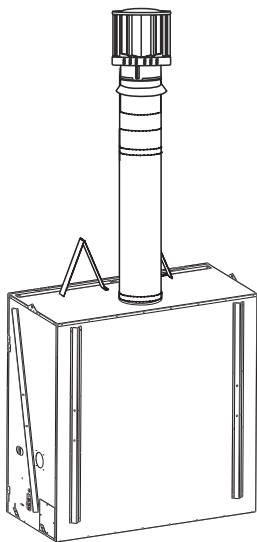

See graph to determine the required vertical rise V_T for the required horizontal run H_T .

REQUIRED VERTICAL RISE IN FEET V_T

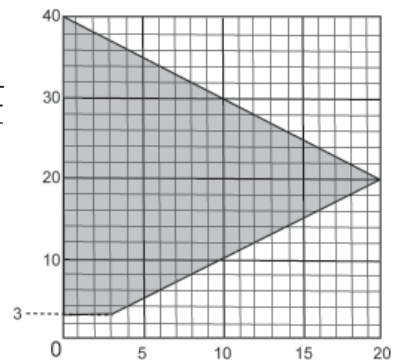

HORIZONTAL VENT RUN PLUS OFFSET IN FEET H_T
The shaded area within the lines represents acceptable values for H_T and V_T .

For vent configurations requiring more than zero 90° elbow (top exit) or one 90° elbow (rear exit), the following formulas apply:

- Formula 1:** $H_T \leq V_T$
- Formula 2:** $H_T + V_T \leq 40$ feet

VERTICAL TERMINATION

when $(H_T) > (V_T)$
 Simple venting configurations

FIGURE 10

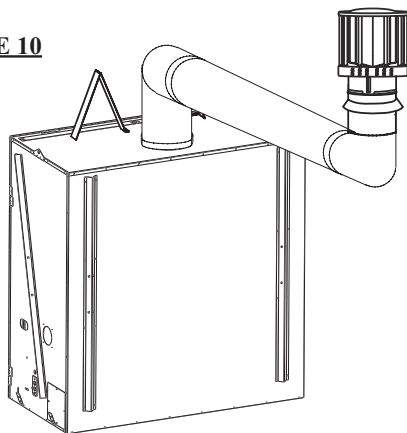

See graph to determine the required vertical rise V_T for the required horizontal run H_T .
 For vent configurations requiring more than two 90° elbow (top exit) or one 90° elbow (rear exit), the following formulas apply:

- Formula 1:** $H_T \leq 3V_T$
- Formula 2:** $H_T + V_T \leq 40$ feet

Example 7:

- $V_1 = 2$ ft
- $V_2 = 1$ ft
- $V_3 = 1.5$ ft

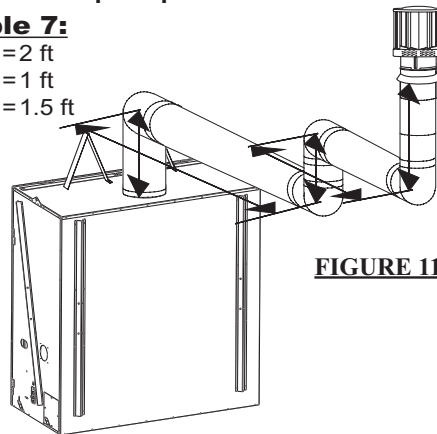

FIGURE 11

- $V_T = V_1 + V_2 + V_3 = 2 + 1 + 1.5 = 4.5$ ft
- $H_1 = 6$ ft
- $H_2 = 2$ ft
- $H_R = H_1 + H_2 = 6 + 2 = 8$ ft
- $H_O = .03(\text{four } 90^\circ \text{ elbows} - 90^\circ) = .03(90 + 90 + 90 + 90 - 90) = 8.1$ ft
- $H_T = H_R + H_O = 8 + 8.1 = 16.1$ ft
- $H_T + V_T = 16.1 + 4.5 = 20.6$ ft

Formula 1: $H_T \leq 3V_T$
 $3V_T = 3 \times 4.5 = 13.5$ ft
 $16.1 > 13.5$

Since this formula is not met, this vent configuration is **unacceptable**.

Formula 2: $H_T + V_T \leq 40$ feet
 $20.6 \leq 40$

Since only formula 2 is met, this vent configuration is unacceptable and a new fireplace location or vent configuration will need to be established to satisfy both formulas.

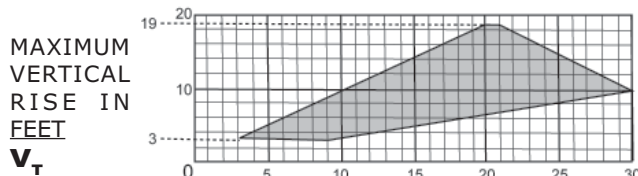

HORIZONTAL VENT RUN PLUS OFFSET IN FEET H_T

The shaded area within the lines represents acceptable values for H_T and V_T .

MINIMUM AIR TERMINAL LOCATION CLEARANCES

FIGURE 12

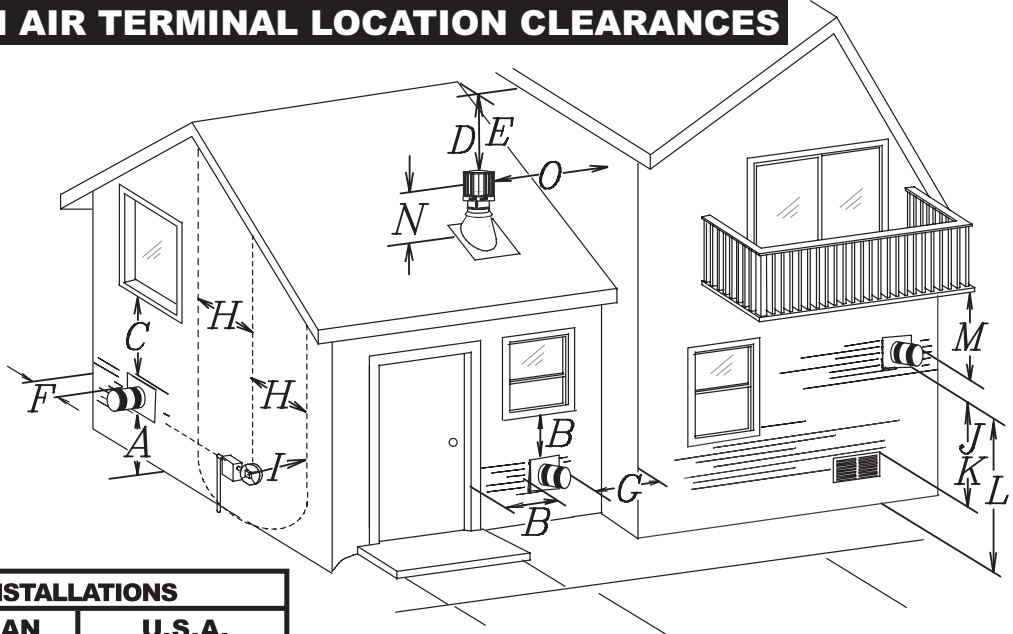

INSTALLATIONS			
	CANADIAN	U.S.A.	
A	12 INCHES	12 INCHES	Clearance above grade, veranda porch, deck or balcony.
B	12 INCHES	9 INCHES	Clearance to windows or doors that open.
C	12 INCHES*	12 INCHES*	Clearance to permanently closed windows.
D	18 INCHES**	18 INCHES**	Vertical clearance to ventilated soffit located above the terminal within a horizontal distance of 2 feet from the centerline of the terminal.
E	12 INCHES**	12 INCHES**	Clearance to unventilated soffit.
F	0 INCHES	0 INCHES	Clearance to an outside corner wall.
G	0 INCHES	0 INCHES	Clearance to an inside <i>non</i> -combustible corner wall or protruding <i>non</i> -combustible obstructions (chimney, etc.).
	2 INCHES	2 INCHES	Clearance to an inside combustible corner wall or protruding combustible obstructions (vent chase, etc.).
H	3 FEET	3 FEET****	Clearance to each side of the centerline extended above the meter / regulator assembly to a maximum vertical distance of 15ft.
I	3 FEET	3 FEET****	Clearance to a service regulator vent outlet.
J	12 INCHES	9 INCHES	Clearance to a non-mechanical air supply inlet to the building or a combustion air inlet to any other appliance.
K	6 FEET	3 FEET†	Clearance to a mechanical air supply inlet.
L	7 FEET‡	7 FEET****	Clearance above a paved sidewalk or paved driveway located on public property.
M	12 INCHES††	12 INCHES****	Clearance under a veranda, porch, deck or balcony.
N	16 INCHES	16 INCHES	Clearance above the roof.
O	2 FEET†*	2 FEET†*	Clearance from an adjacent wall including neighbouring buildings.

* Recommended to prevent condensation on windows and thermal breakage
 ** It is recommended to use a heat shield and to maximize the distance to vinyl clad soffits.
 **** This is a recommended distance. For additional requirements check local codes.
 † 3 feet above if within 10 feet horizontally.
 ‡ A vent shall not terminate directly above a sidewalk or paved driveway that is located between two single family dwellings and serves both dwellings.
 †† Permitted only if the veranda, porch, or deck is fully open on a minimum of two sides beneath the floor.
 †* Recommended to prevent recirculation of exhaust products. For additional requirements check local codes.

INSTALLATION / FRAMING

WALL AND CEILING PROTECTION

HORIZONTAL VENT SECTIONS: A minimum clearance of 2" all around the vent pipe on all horizontal runs to combustibles is required except for clearances in fireplace enclosures**. Use firestop spacer assembly W010-1797 (supplied).

VERTICAL VENT SECTIONS: A minimum of 1" all around the vent pipe on all vertical runs to combustibles is required except for clearances in fireplace enclosures**. Use firestop spacer W615-0075 (not supplied).

** Horizontal and vertical sections require 5" and 9" clearance from combustibles, respectively. See minimum enclosure clearances section.

HORIZONTAL INSTALLATION

This application occurs when venting through an exterior wall. Having determined the correct height for the air terminal location, cut and frame a hole in the exterior wall 14 7/8" wide by 14 7/8" high to accommodate the firestop assembly. Dry fit the firestop assembly before proceeding to ensure the brackets on the rear surface fit to the inside surface of the horizontal framing.

NOTE: The firestop assembly must be installed with the vent shield to the top.

The length of the vent shield may be cut shorter for combustible walls that are less than 8 1/2" thick but the vent shield must extend the full depth of the combustible wall.

1. Apply a bead of caulking (not supplied) around the corner edge of the inside surface of the firestop assembly, fit the firestop assembly to the hole and secure using the 4 screws W415-0026 (supplied in your manual baggy).
2. Once the vent pipe is installed in its final position, apply high temperature sealant W573-0007 (not supplied) between the pipe and the firestop.

NOTE: Do not fill the cavity between the pipe and the framing with any type of material.

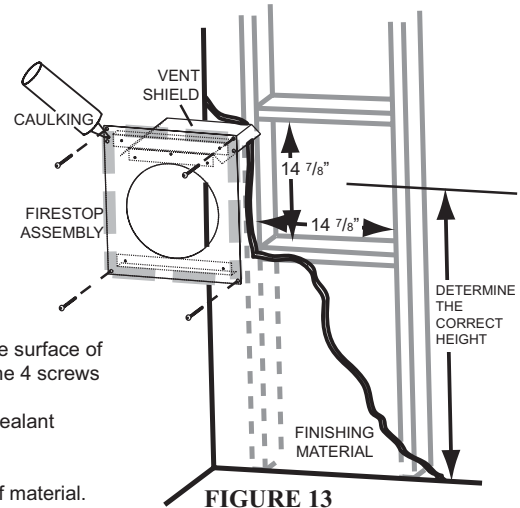

FIGURE 13

VERTICAL INSTALLATION

This application occurs when venting through a roof. Installation kits for various roof pitches are available from your Authorized dealer. See Accessories to order the specific kit required.

1. Determine the air terminal location, cut and frame 14 1/2" x 14 1/2" openings in the ceiling and the roof to provide the minimum 2" clearance between the fireplace pipe / liner and any combustible material. Try to centre the exhaust pipe location midway between two joist to prevent having to cut them. Use a plumb bob to line up the centre of the openings. Do not fill this space with any type of material.

A vent pipe shield will prevent any materials such as insulation, from filling up the 1" air space around the pipe. Nail headers between the joist for extra support.

2. Apply a bead of caulking (not supplied) to the framework or to the Wolf Steel vent pipe shield plate or equivalent (in the case of a finished ceiling), and secure over the opening in the ceiling. A firestop must be placed on the bottom of each framed opening in a roof or ceiling that the venting system passes through. Apply a bead of caulking all around and place a firestop spacer over the vent shield to restrict cold air from being drawn into the room or around the fireplace. Ensure that both spacer and shield maintain the required clearance to combustibles. Once the vent pipe is installed in its final position, apply sealant W573-0002 (not supplied) between the pipe and the firestop spacer.

3. In the attic, after the pipe has been installed, slide the vent pipe collar down to cover up the open end of the shield and tighten. This will prevent any materials, such as insulation, from filling up the 1" air space around the pipe.

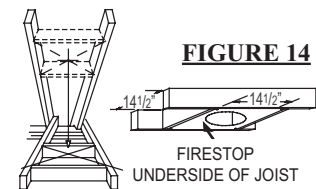

FIGURE 14

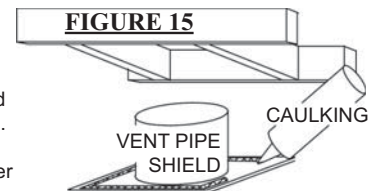

FIGURE 15

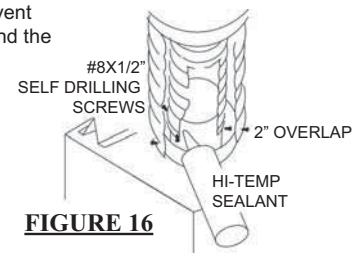
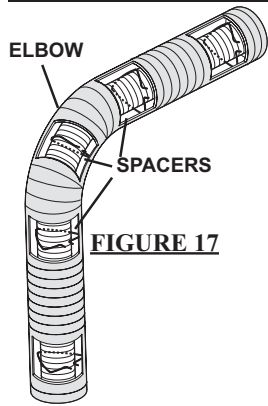

FIGURE 16

USING FLEXIBLE VENT COMPONENTS



! WARNING

Do not allow the inside vent pipe to bunch up on horizontal or vertical runs and elbows. Keep it pulled tight. A 3/4" air gap between the liner and the outer liner all around is required for safe operation. A spacer is required at the start, middle and end of each elbow to ensure this gap is maintained. Spacers are attached to the inner flexible vent pipe at pre-determined intervals to maintain a 3/4" air gap to the outer flexible vent pipe. These spacers must not be removed.

For safe and proper operation of the fireplace, follow the venting instructions exactly.

All inner exhaust and outer intake vent pipe joists may be sealed using either red RTV high temperature silicone sealant or black high temperature Mill Pac with the exception of the fireplace exhaust flue collar which must be sealed using Mill Pac (not supplied).

Use only approved flexible liner kits marked:



"Wolf Steel Approved Venting" as identified by the stamp only on the 10" outer liner.

Eight inches (8") is the minimum bend radius allowed for the ten inch (10") diameter flexible liner.

For optimum performance it is recommended that all horizontal runs have a minimum 1/4" rise per foot using flexible venting.

HORIZONTAL AIR TERMINAL INSTALLATION

NOTE: Direct vent terminals shall not be recessed into a wall or siding.

1. Stretch the 8" diameter flex vent pipe to the required length taking into account the additional length needed for the finished wall surface. Slip the vent pipe a minimum of 2" over the inner sleeve of the air terminal and secure with 6 #8 screws. Apply a heavy bead of the high temperature sealant W573-0002 (not supplied).
2. Using the 10" diameter flex vent pipe, slide over the outer combustion air sleeve of the air terminal and secure with 6 #8 screws. Seal as before.
3. Insert the flex vent pipe through the firestop maintaining the required clearance to combustibles. Secure to the exterior wall and make weather tight by sealing with caulking (not supplied).
4. Apply a heavy bead of the high temperature sealant W573-0007 (not supplied) with the unit, to the inside of the 8" liner approximately 1" from the end. Slip the liner a minimum of 2" over the fireplace vent collar and secure with 6 #8 screws.
5. If more than one liner is run we recommend supporting every 3ft.
6. Using the 10" diameter flex vent pipe, apply sealant, slide a minimum of 2" over the fireplace combustion air collar and secure with 6 #8 screws.

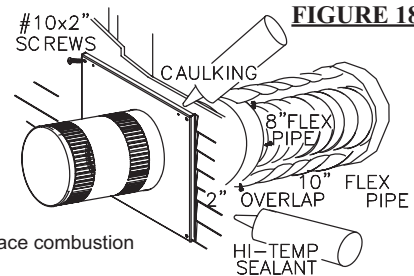

VERTICAL AIR TERMINAL INSTALLATION

1. Move the fireplace into position.
2. Fasten the roof support to the roof using the screws provided. The roof support is optional. In this case the venting is to be adequately supported using either an alternate method suitable to the authority having jurisdiction or the optional roof support. (Figure 18).
3. Stretch the inner exhaust vent pipe to the required length. Slip it a minimum of 2" over the inner pipe of the air terminal connector and secure with 6 #8 screws. Seal using a heavy bead of the high temperature sealant W573-0002 (not supplied). (Figure 19).
4. Repeat using the air intake vent pipe. (Figure 19).
5. Thread the air terminal connector pipe assembly down through the roof. The air terminal must be located vertically and plumb. Attach the air terminal connector assembly to the roof support, ensuring that the top of the air terminal is 16" above the highest point that it penetrates the roof. (Figure 22) **DO NOT CLAMP THE FLEXIBLE VENT PIPE. If the attic space is tight, we recommend threading the Wolf Steel vent pipe collar or equivalent loosely onto the air terminal assembly as it is passed through the attic.**
6. Remove nails from the shingles, above and to the sides of the chimney. Place the flashing over the air terminal leaving a min. 3/4" of the air terminal connector showing above the top of the flashing. Slide the flashing underneath the sides and upper edge of the shingles. Ensure that the air terminal connector is properly centred within the flashing, giving a 3/4" margin all around. Fasten to the roof. Do not nail through the lower portion of the flashing. Make weather-tight by sealing with caulking. Where possible, cover the sides and top edges of the flashing with roofing material. (Figure 20)
7. Aligning the seams of the terminal and air terminal connector, place the terminal over the air terminal connector making sure the liner goes into the terminal. Secure with the three screws provided. (Figure 20)
8. Apply a heavy bead of weatherproof caulking 2 inches above the flashing. Note: Maintain a minimum 2" space between the air inlet base and the storm collar. Install the storm collar around the air terminal connector and slide down to the caulking. Tighten to ensure that a weather-tight seal between the air terminal connector and the collar is achieved. (Figure 21)
9. If more vent pipe needs to be used to reach the fireplace, couple them together. The vent system must be supported approximately every 3 feet for both vertical and horizontal runs. Use noncombustible strapping to maintain a clearance to combustibles.

FIGURE 19

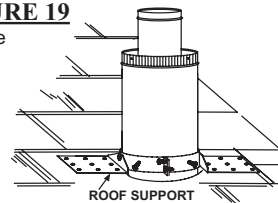

FIGURE 20

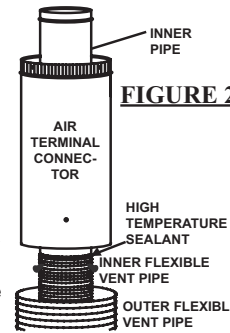
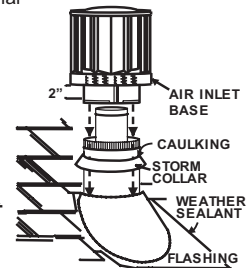

FIGURE 21



FIREPLACE VENT CONNECTION

1. Install the 8" diameter flexible vent pipe to the fireplace. Secure with 6 screws. Seal the joint and screw holes using the high temperature sealant W573-0007 (not supplied).
2. Install the 10" diameter flexible vent pipe to the fireplace. Attach and seal the joints.

FIGURE 22

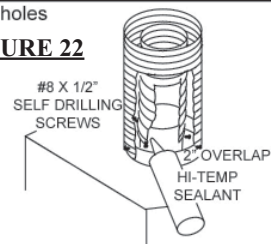

GAS INSTALLATION

Proceed once the vent installation is complete.

NOTE: All gas connections must be contained within the fireplace when complete.

1. Move the fireplace into position and secure to the floor through the 1/4" holes located at either side of the base.
 2. The fireplace is designed to accept 3/8" gas supply line. The fireplace is equipped with a 3/8" manual shut-off valve.
 3. Connect the gas supply in accordance to local codes. In the absence thereof, install according to the National Installation Code.
 4. When flexing any gas line, support the gas valve so that the lines are not bent or kinked.
 5. Check for gas leaks by brushing on a soap and water solution.
- Do not use open flame.

Purge all gas lines with the glass door of the fireplace removed. Assure that a continuous gas flow is at the burners before re-installing the door.

MOBILE HOME

This appliance is certified to be installed as an OEM (Original Equipment Manufacturer) installation in a manufactured home or mobile home and must be installed in accordance with the manufacturer's instructions and the Manufactured Home Construction and Safety Standard, Title 24 CFR, Part 3280, in the United States or the Mobile Home Standard, CAN/CSA Z240 MH Series, in Canada. This appliance is only for use with the type(s) of gas indicated on the rating plate. A conversion kit is supplied with the mobile home appliance.

This Mobile/Manufactured Home Listed appliance comes factory equipped with a means to secure the unit. The fireplace is equipped with two 1/4" diameter holes located in the front left and right corners of the base. For mobile home installations, the fireplace must be fastened in place. Use #10 hex head screws, inserted through the holes in the base to secure. Always turn off the pilot and the fuel supply at the source, prior to moving the mobile home. After moving the mobile home and prior to lighting the fireplace, ensure that the logs are positioned correctly.

This appliance is certified to be installed in an aftermarket permanently located, manufactured (mobile) home, where not prohibited by local codes. This fireplace is only for use with the type of gas indicated on the rating plate. This fireplace is not convertible for use with other gases, unless a certified kit is used.

Conversion Kits

The mobile home appliance is field convertible between Natural Gas (NG) and Propane (LP). To convert from one gas to another consult your Authorized dealer/distributor.

RESTRICTING VERTICAL VENTS

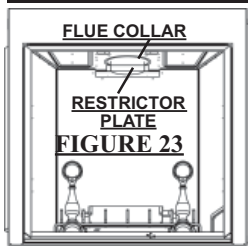

Vertical terminations may display a very active flame. If this appearance is not desirable, the vent exit must be restricted using restrictor plate, W500-0321. This reduces the velocity of the exhaust gases, slowing down the flame pattern and creating a more traditional appearance.

The plate has a series of holes to allow for adjustment.

Remove the two screws on either side of the exhaust collar inside the firebox. Install the plate in the desired set of holes, then replace the screws.

It is recommended to secure in the third set of holes which causes the greatest amount of restriction for vent lengths between 15 and 30 feet.

FRAMING

WARNING	ATTENTION	ATENCIÓN
THE STANDOFFS HAVE BEEN SHIPPED FLAT. BEFORE FRAMING, ENSURE THE STANDOFFS ARE BENT UP AND SCREWED INTO PLACE.	LES ESPACEURS SONT ENBAÏLLÉS À PLAT AVANT DE CONSTRUIRE L'OSATURE. ASSUREZ-VOUS QUE LES ESPACEURS SONT PLIÉS ET FIXÉS EN PLACE À L'AIDE DE VIS.	LAS TRABAS PERMANECEN PLANAS DURANTE EL ENVÍO. ANTES DE LA INSTALACIÓN, VERIFIQUE QUE LAS TRABAS SE PLEGUEN HACIA ARRIBA Y SE ATORNILLEN CORRECTAMENTE.

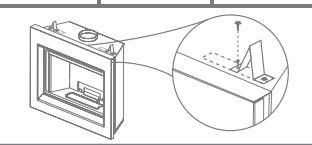

The *Dream*™ can be installed with a rectangular opening.

It is best to frame your fireplace after it is positioned and the vent system is installed. Use 2x4's and frame to local building codes.

NOTE: In order to avoid the possibility of exposed insulation or vapor barrier coming in contact with the fireplace body, it is recommended that the walls of the fireplace enclosure be "finished" (i.e.: drywall/sheetrock), as you would finish any other outside wall of a home. This will ensure that clearance to combustibles is maintained within the cavity.

For convenience, the stand-offs have been shipped flat. Before framing, ensure the stand-offs are opened and screwed in place.

FIGURE 24 either the hearth or the finished floor. It is not necessary to install a hearth extension, but the fireplace should be raised to be flush with

When roughing in the fireplace, raise the fireplace to accommodate for the thickness of the finished floor materials, i.e. tile, carpeting, hard wood, which if not planned for will interfere with the removal of the hearth strip, which must be removed to access the firebox. Objects placed in front of the fireplace should be kept a minimum of 48" away from the front face.

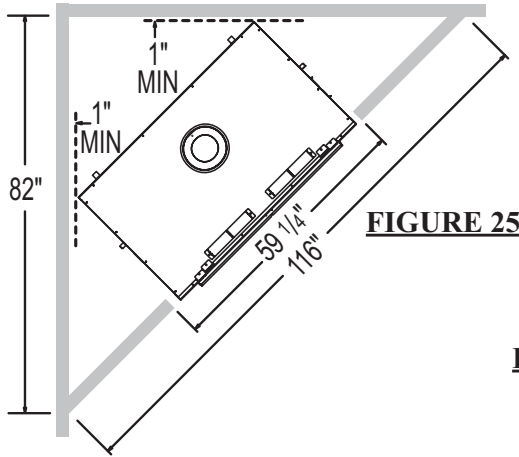

FIGURE 25

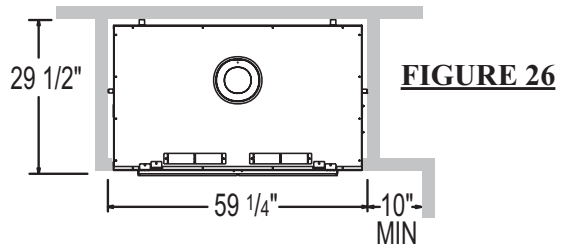

FIGURE 26

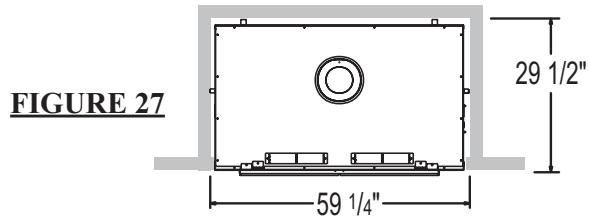
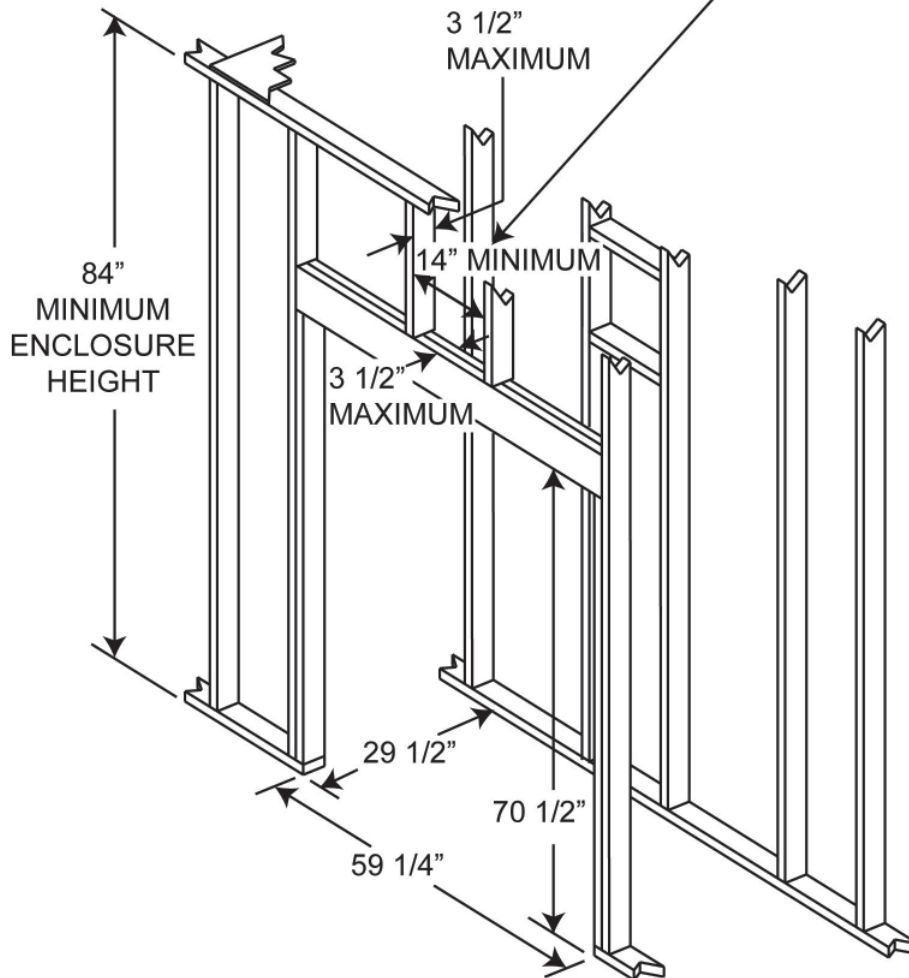

FIGURE 27

FIGURE 28

! WARNING

Do not build into this area - it must be left clear to provide adequate clearance for the vent in this 14" wide area centered along the front of the fireplace. No combustibles are allowed.



MINIMUM CLEARANCE TO COMBUSTIBLES

Maintain these minimum clearances to combustibles from fireplace and vent surfaces:

Fireplace framing:

- 0" to stand-offs

Combustible Fireplace finishing:

- 0" to rear
- 29 1/2" recessed depth
- 84" from bottom of unit to enclosure top
- 2" to top, sides, and bottom of vent pipe*
- 84" from bottom of unit to ceiling

Non-Combustible Fireplace finishing:

- Front - 5 1/2" to sides of fireplace opening
- 23 3/4" to top of fireplace opening

* See Venting Section

It is recommended that the walls of the fireplace enclosure be finished. This would ensure that clearance to combustibles is maintained within the cavity.

Non-combustible finishing material (i.e. cement board, brick, stone, tile) must be used to finish the front of the unit.

FIGURE 29

! WARNING
 Use only non-combustible material such as cement board, ceramic tile, marble, etc. when finishing to the fireplace. **DO NOT USE WOOD OR DRYWALL.**

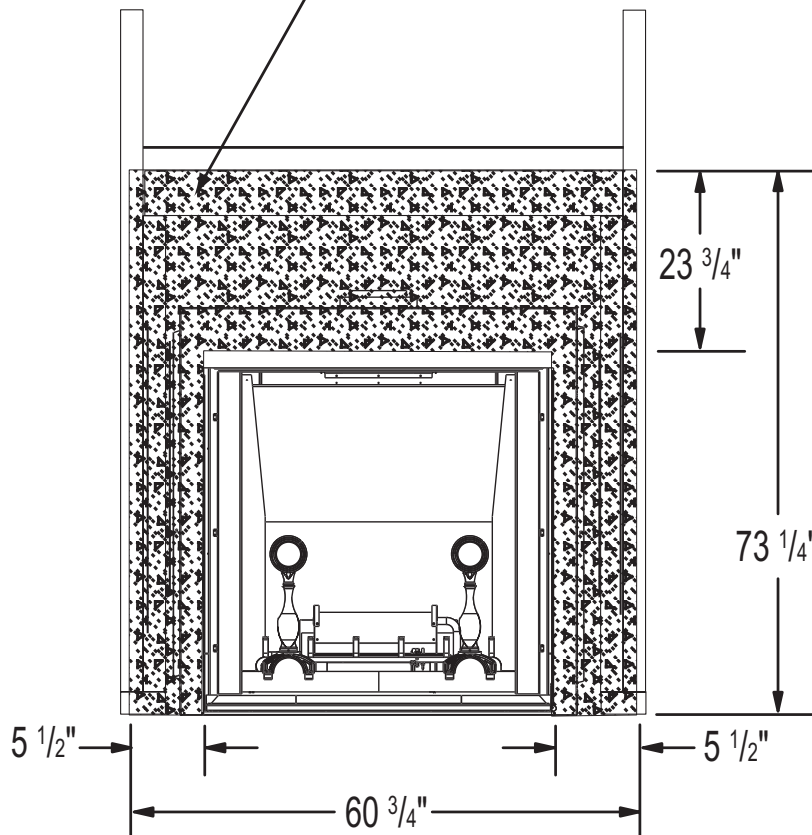

! WARNING
Facing and/or finishing material must never overhang into the fireplace opening.

MINIMUM MANTEL AND ENCLOSURE CLEARANCES

IMPORTANT:

The *Dream*™ requires a minimum inside enclosure height of 84" measured from the bottom of the fireplace. For temperature requirements, this area must be left unobstructed.

Combustible mantel clearance can vary according to the mantel depth. Use the graph to help evaluate the clearance needed.

It is recommended that the enclosure be ventilated at the top and bottom to circulate the hot air with 2, 40" square openings.

FIGURE 30

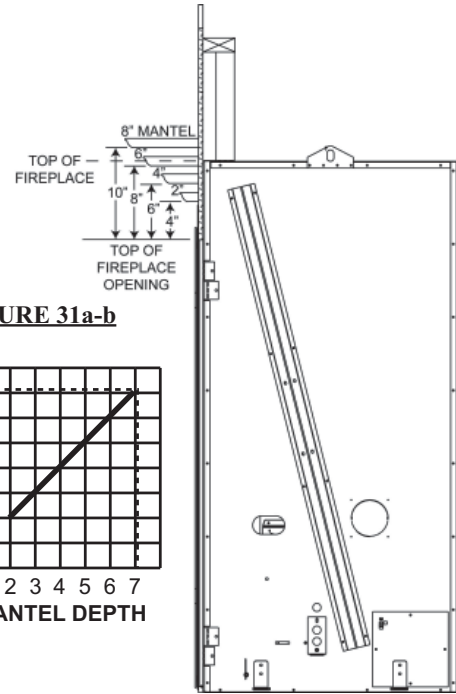
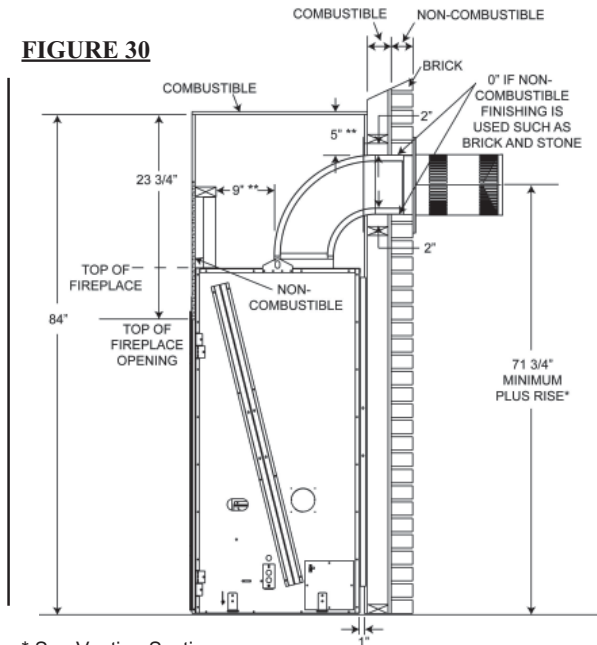

FIGURE 31a-b

* See Venting Section

** Within the fireplace enclosure a 9" clearance between the vertical vent run and the combustible materials on the front facing of the enclosure is required. Similarly, a 5" clearance to combustible materials from the top of the horizontal vent run is required. All other clearances within the enclosure, including where the vent pipe exits the enclosure are subject to 2" for horizontal and 1" for vertical.

ELECTRICAL CONNECTION

Do NOT use the fireplace if any part has been under water. Call a qualified service technician IMMEDIATELY to have the fireplace inspected for damage to the electrical circuit.
If access to the control area is necessary BEFORE INSTALLATION, remove the access panel. Located along the right side of firebox. The access panel must be re-installed before operating the unit.

HARD WIRING CONNECTION

It is necessary to hard wire this fireplace. Permanently framing the fireplace with an enclosure, requires the fireplace junction box to be hard wired. This fireplace must be electrically connected and grounded in accordance with local codes. In the absence of local codes, use the current CSA C22.1 CANADIAN ELECTRICAL CODE in Canada or the ANSI/NFPA 70-1996 NATIONAL ELECTRICAL CODE in the United States.

SCHEMATIC

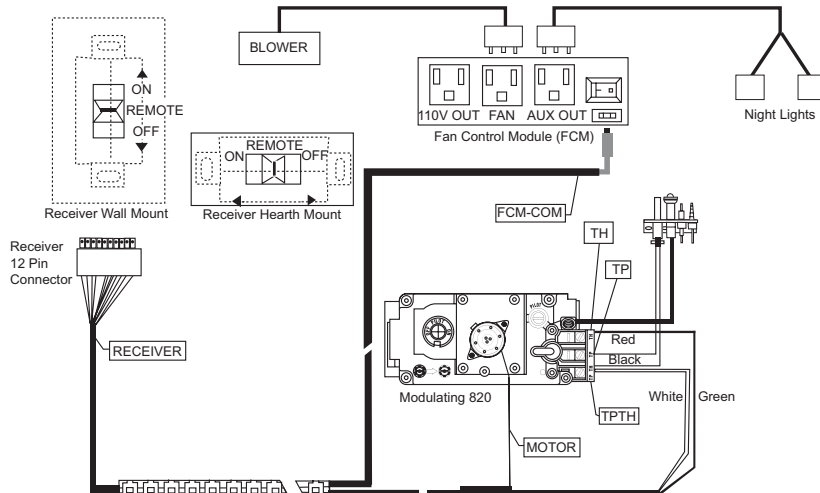
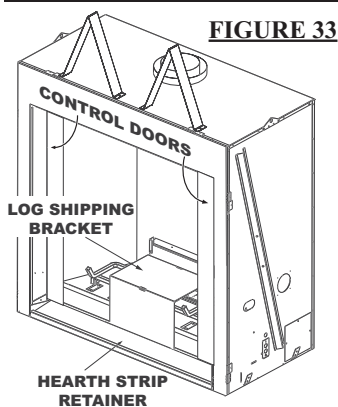

FIGURE 32

FINISHING

DOOR REMOVAL



Before the glass door can be removed, the control doors must be opened and the hearth strip and screen assembly must be removed.

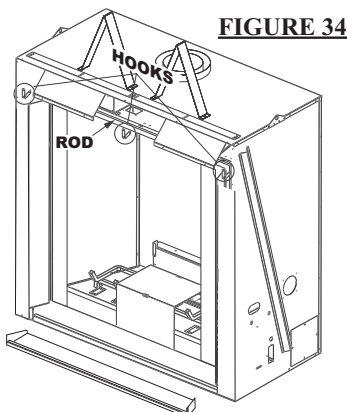

With the control doors pulled open, you can now lift the hearth strip up and away from the front of the fireplace. The curtain assembly can be removed by lifting the rod out from the three hooks at the top inside edge of the door opening.

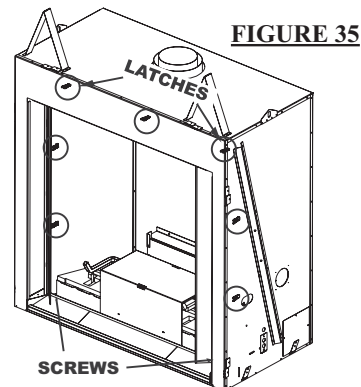

The glass door is secured to the firebox with 7 latches. 2 on each side, and 3 across the top plus 2 screws. Pull the handle of the latch forward, then lift the hooks out from the slot in the door frame to release the top and sides of the door. Using a Screw Driver remove the 2 screws in the bottom corners of the door. Lift the door out from the retainer along the bottom of the door. We recommend 2 people remove door due to size and weight. Pull the bottom edge of the door out from the fireplace until the top will pivot forward. **Handle carefully as the door is extremely heavy.**

LOG SHIPPING BRACKET

FIGURE 36

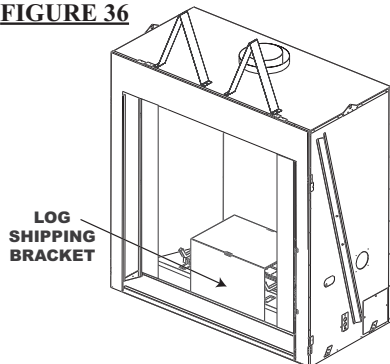

Before installing the logs, you must first remove the log shipping bracket. Lift up to remove. Discard once removed.

GLASS/DOOR REPLACEMENT

1. Place the door frame face down careful not to scratch the paint.
2. Center the gasketed glass inside the door frame with the thick side of the gasket facing up.
3. Bend the glass retainers located along the edge of the door frame over the gasket holding the glass in place. Careful not to break the glass.

NOTE: Care must be taken when removing and disposing of any broken glass or damaged components. Be sure to vacuum up any broken glass from inside the fireplace before operation.

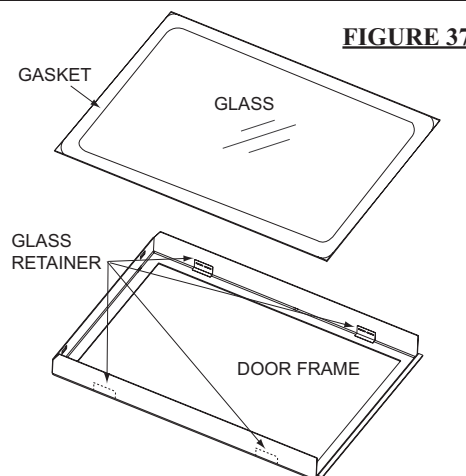

BRICK PANEL INSTALLATION

Brick panels are shipped separate from unit due to the brittle material of the bricks, care must be taken not to bend or force them into place.

When shipped, the brick panels range in varying shades of Sandstone. During initial use, the panels will darken temporarily. The appearance of the panels will permanently lighten in color with use.

INSTALL PANELS IN THE FOLLOWING ORDER:

FIGURE 38

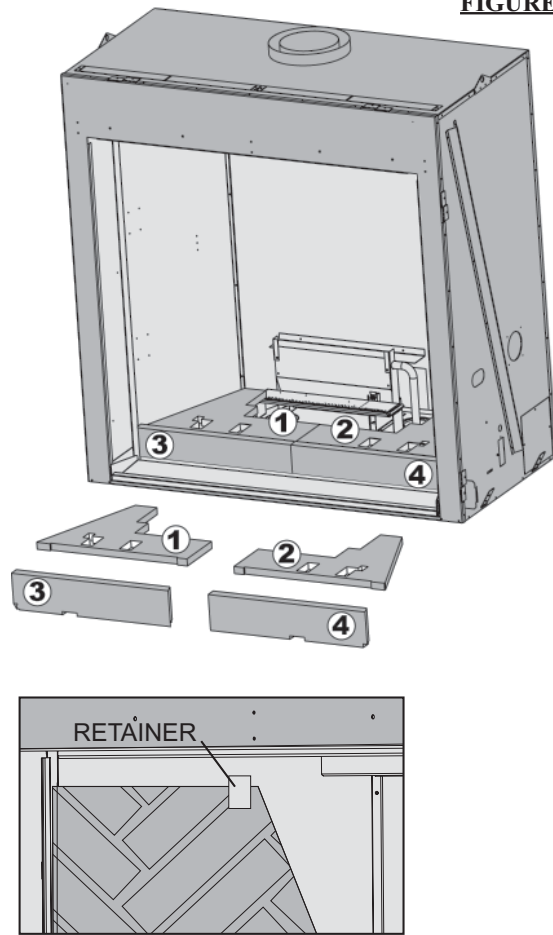

Secure the Left Panel **6** and Right Panel **8** using the retainers located in the top left and right corners of the firebox.

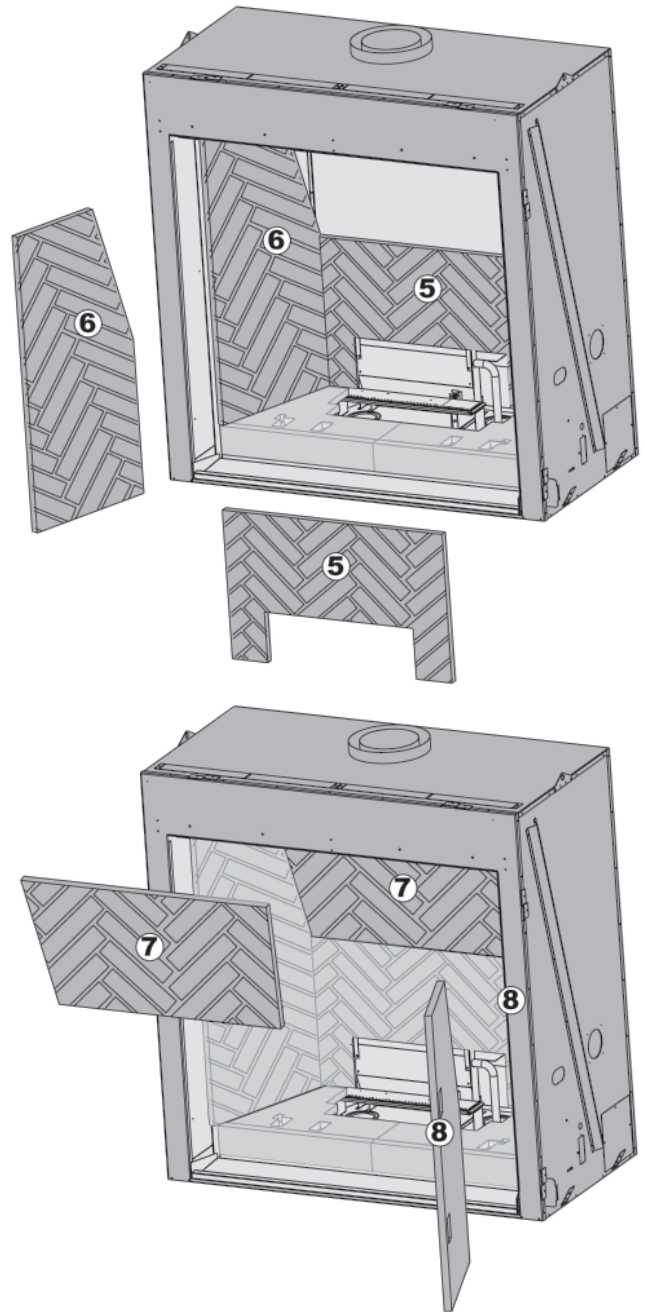

To install the Front Left **9**, Centre **10**, and Right **11** Hearth Panels you must first remove one of the Right or Left End Hearth Retainers.

END HEARTH RETAINERS

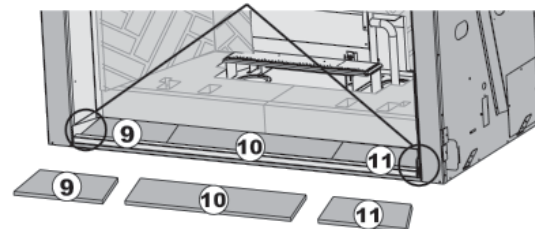

ANDIRON PLACEMENT

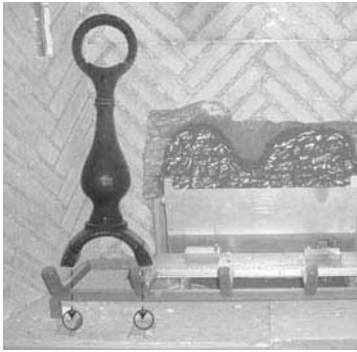

Andirons are packaged separately inside the unit and must be installed prior to the log installation. Place the Andiron on the Andiron brackets located at the front of the unit lining up the holes. Secure using the screws provided. Repeat on other side.

FIGURE 39

LOG PLACEMENT

PHAZER™ logs and glowing embers, exclusive to Wolf Steel Ltd. Fireplaces, provide a unique and realistic glowing effect that is different in every installation. Take the time to carefully position the glowing embers for a maximum glowing effect. Log colors may vary. During the initial use of the fireplace, the colors will become more uniform as color pigments burn in during the heat activated curing process.

FIGURE 40a-h

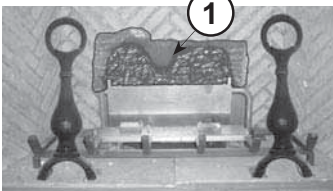

1. Center the rear log (#1) behind the rear burner and onto the log support.

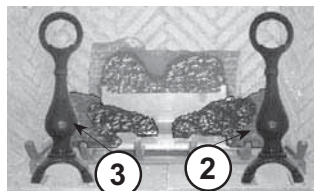

2. Place log#2 and log#3 onto the locating pins. The logs should sit flat on the burner.

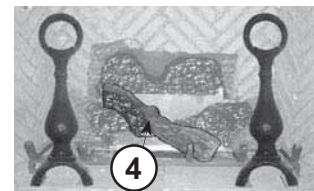

3. Place the locating hole on the underside of log#4 onto the locating pin on top of log#3. The notch at the opposite end of log#4 sits on the third grate post in from the right side.

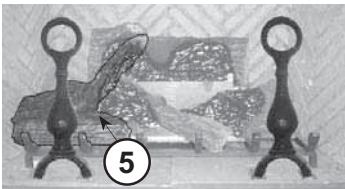

4. Place the small branch of log#5 into the notch on log#3. The notches on the bottom edge of log #5 should sit on the first and second grate posts from the left.

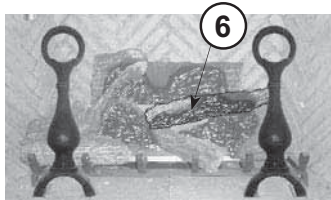

5. Place the small end of log#6 into the front notch of log#4. Place the locating hole in the large end of log#6 onto the locating pin on top of log#2.



6. Place the pin in log #7 in the hole in log #6. The log should sit in the notch on log #2 and the bottom should rest along the right side of the Andiron.

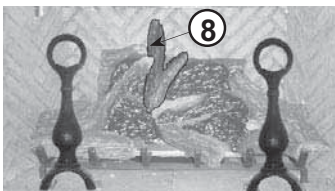

7. Place the large end of log#8 into the rear notch of log#4. The small branch of log#8 sits in the notch located on top of log#1.

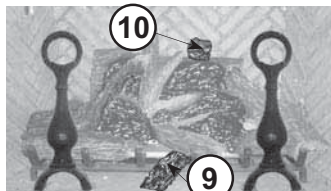

8. Place log#9 onto the grate as though it had burnt off log#5. Place log#10 onto the locating pin on log#1. Again, log#10 should be aligned as though it has burnt off of log#7.

CHARCOAL EMBERS

Randomly place the charcoal embers along the front and sides of the Hearth Panels in a realistic manner. Fine dust found in the bottom of the bag should not be used.

VERMICULITE

Sprinkle vermiculite around the charcoal embers.

NOTE: Both charcoal embers and vermiculite are not to be placed on the burner.

GLOWING EMBERS

Tear the embers into pieces and place along the front row of ports covering all of the burner area in front of the small logs (#2 & #3). Care should be taken to shred the embers into thin, small irregular pieces as only the exposed edges of the fibre hairs will glow. The ember material will only glow when exposed to direct flame; however, care should be taken to not block the burner ports.

Blocked burner ports can cause an incorrect flame pattern, carbon deposits and delayed ignition. phazer™ logs glow when exposed to direct flame. Use only certified “glowing embers” and phazer™ logs available from your Authorized dealer.

NIGHT LIGHT™ REPLACEMENT

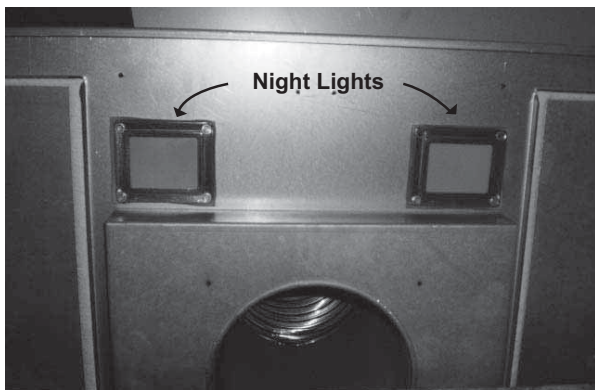

Your *Dream*™ comes equipped with 2 “Night Lights™”. The lights have been pre-wired and is controlled from the remote control.

If in the event the lamps or lens need replacing, follow these instructions.

Shut off breaker at main power supply.

Remove the four screws that secure the lens frame to the Firebox top. This frame retains the glass lens. The lamp can now be accessed.

FIGURE 41 FIREBOX TOP

FIGURE 42

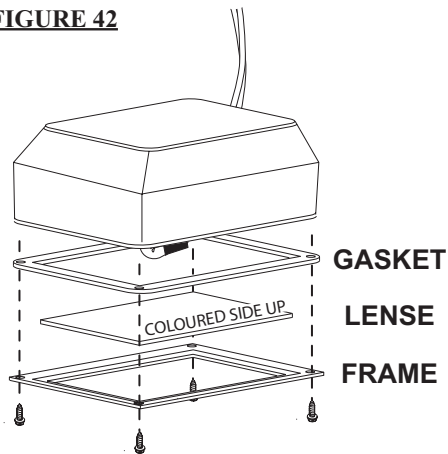

NOTE: Do not handle the lamp (bulb) with bare fingers, protect with a clean dry cloth.

The lamp will pull straight out of the socket. Replace with Wolf Steel parts only, as lamp and lens are special “high temperature” products. When re-installing, ensure integrity of gasket seal.

THE FIREBOX MUST BE SEALED.

Over tightening the screws could break the lens.

“Light Leakage” from the holes in the housing lamp may be observed. The holes in the lamp housing are necessary for ventilation and must not be covered.

REMOTE AND VALVE ACCESS

The control area can be accessed either through the control door or through the access panel inside the firebox.

INNER ACCESS PANEL

Follow the door removal instructions. Remove the right side brick panel. Remove the four screws from the access panel.

NOTE: A new gasket will be required, when re-installing the access panel (see replacement parts).

REMOTE RECEIVER REMOVAL

1. Open the right control door by pulling bottom portion away from magnet catch.
2. Remove the hearth strip by lifting up and away from unit.
3. Remove the receiver by pulling the left side of the plate away from the bracket.
4. Once disengaged pull the wiring harness out from the back of receiver.

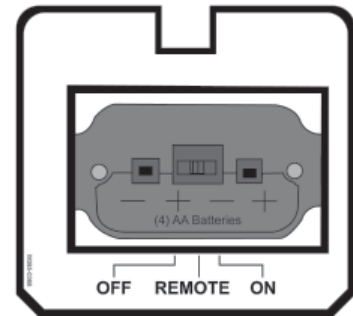

FIGURE 43

CONTROL MODULE REMOVAL

1. Remove access panel from inside the firebox.
2. Unplug the control module from the junction box
3. Pull up on the control module being held down with velcro and disconnect the plugs (fan, aux). Remove wiring harness from the front of the casing.
4. Install the new control module (*see schematic Pg.16*).

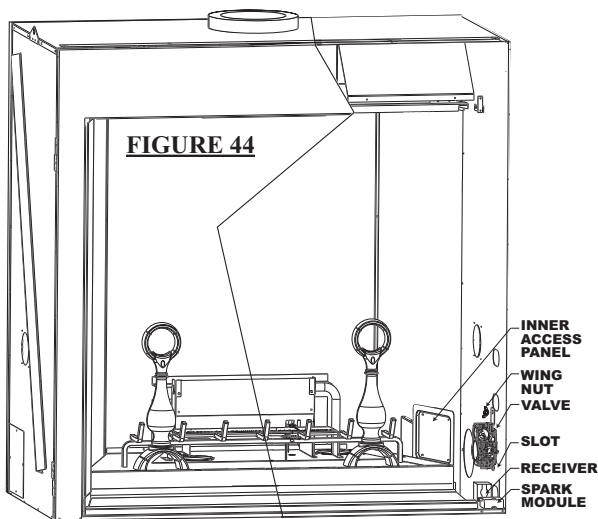

FIGURE 44

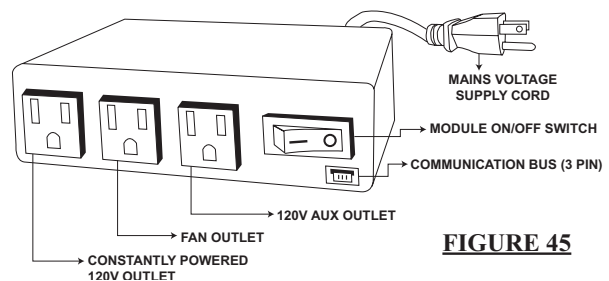

FIGURE 45

VALVE REMOVAL

The valve on The *Dream*™ is piped with two flex connectors (one inlet, one outlet). It can be removed or pulled forward for service.

1. Turn gas off.
2. Open right control door.
3. Remove the wing nut and pivot the valve out from the slot at the bottom of the valve.
4. Slowly pull the valve through the control door being careful not to kink the gas lines or wires.
5. Disconnect inlet/outlet flex connectors, wires and thermocouple.
6. Remove screws securing gas valve to the mounting bracket.

“AUTO SPARK” BATTERY REMOVAL

1. Open the right control door by pulling bottom portion away from magnet catch.
2. Remove the hearth strip by lifting up and away from unit.
3. The spark module is located in the front right corner of the unit (see photo below).
4. Disengage the battery compartment door from the top of module.
5. Replace battery and re-install compartment door.

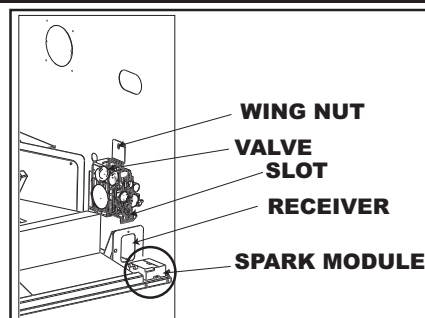

FIGURE 46

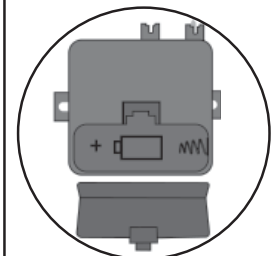
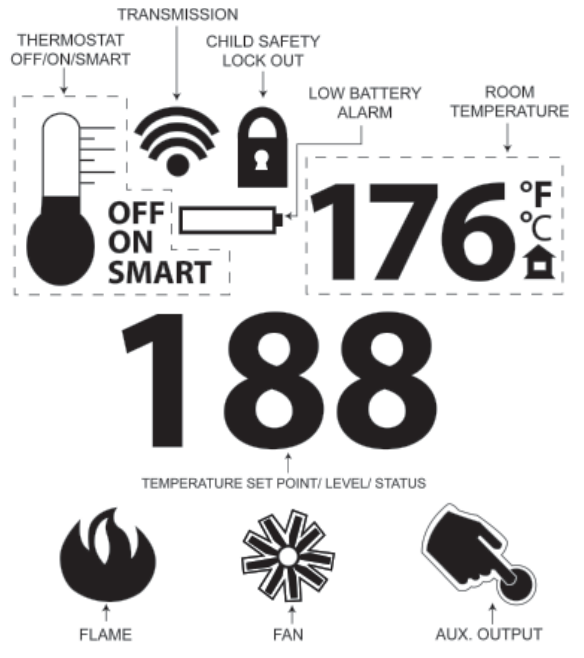

FIGURE 47

OPERATION / MAINTENANCE

GENERAL TRANSMITTER LAYOUT

FIGURE 48



FIREPLACE OPERATION

1. Install 4 AA batteries into the receiver battery bay as indicated on the battery cover (+/-).
2. Place the 3 position slider switch in the "Remote" position.
3. Using the end of a paper clip, or other similar object, insert the end of the paper clip into the hole marked "PRG" on the receiver front cover. The receiver will "beep" three (3) times to indicate that it is ready to synchronize with the transmitter.
4. Install the 3 AAA batteries in the transmitter battery bay, located on the base of the transmitter. With the batteries already installed in the transmitter, push the "ON" button. The receiver will "beep" four times to indicate the transmitter's command is accepted and set to the particular code of that transmitter. The system is now initialized.

HAND HELD REMOTE OPERATIONS

1. Press the ON/OFF key on the transmitter. The transmitter display will show all active icons on the screen. At the same time the receiver connects the thermopile to the gas valve millivolt coil and the appliance main burner turns on. A single "beep" from the receiver will confirm reception of the command.
2. Press the ON/OFF key on the transmitter. The transmitter LCD display will only show the room temperature and icon. At the same time the receiver disconnects the thermopile from the gas valve millivolt coil and the appliance burner turns off. A single "beep" from the receiver confirms reception of the command.

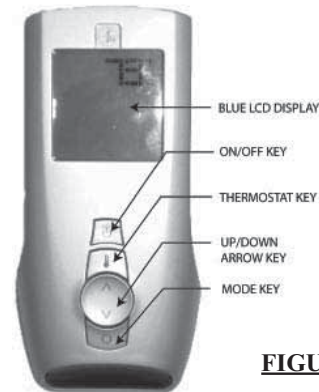

FIGURE 49

TEMPERATURE DISPLAY

1. With the system in the "OFF" position, press the Thermostat Key and the Mode Key at the same time to change from degrees F to C.
2. Look at the LCD screen on the Transmitter to verify that a C or F is visible to the right of the Room Temperature display.

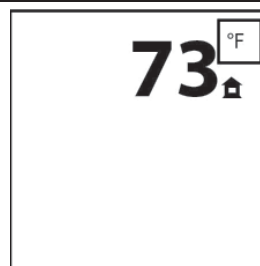

FIGURE 50

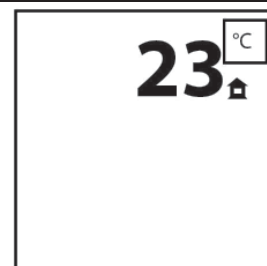
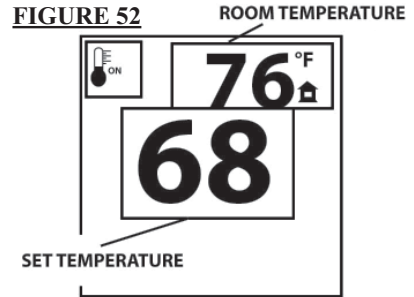

FIGURE 51

ROOM THERMOSTAT

The remote transmitter can operate as a room thermostat. The thermostat can be set to a desired temperature to control the comfort level in the room.

1. Press the Thermostat Key. The LCD display on the Transmitter will show that the room is "ON" and the set temperature is now displayed.
2. To adjust the set temperature, press the Up/Down Arrow Keys until the desired set temperature is displayed on the LCD screen of the Transmitter.



SMART THERMOSTAT

The Smart Thermostat function adjusts the flame height according to the difference between the set temperature and the actual room temperatures. As the room temperature gets closer to the set point the Smart Function will automatically adjust the flame down.

1. Press the thermostat key until the word "SMART" appears to the right of the temperature bulb graphic.
2. To adjust the set temperature, press the Up/Down arrow keys until the desired set temperature is displayed on the LCD screen at the Transmitter.

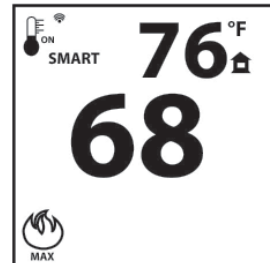

FIGURE 53

FLAME HEIGHT

The remote control has six (6) flame levels. With the system on and the flame level at the maximum, press the Down Arrow Key once and it will reduce the flame height by one step until the flame is turned off.

The Up Arrow Key will increase the flame height each time it is pressed. If the Up Arrow Key is pressed while the system is on but the flame is off, the flame will come on the high position. A single "beep" will confirm reception of the command.



FIGURE 54
Flame OFF

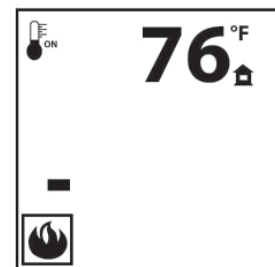

FIGURE 55
Flame at level 1

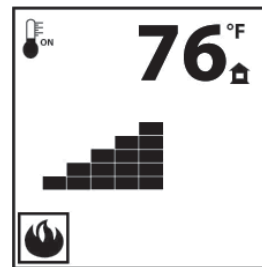

FIGURE 56
Flame at level five



FIGURE 57
Flame at "HI" level six

FAN SPEED

If the appliance is equipped with a hot air circulating fan, the speed of the fan can be controlled by the remote system. The fan speed can be adjusted through six (6) speeds.

1. Use the Mode key to guide you to the fan control icon.
2. Use the Up/Down Arrow keys to turn ON/OFF or adjust the fan speed.

A single "beep" will confirm reception of the command.

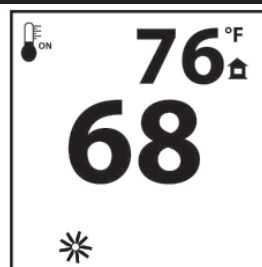

FIGURE 58
Blower Off



FIGURE 59
Blower at HI

CHILD PROOF FUNCTION

This function will lock the keys to avoid unsupervised operation.

1. Press the MODE and UP keys at the same time.
2. To de-activate this function, press the MODE and UP keys at the same time.

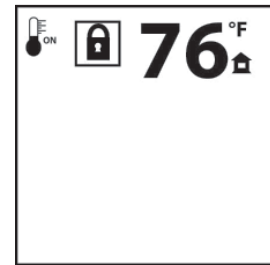

FIGURE 60

NIGHT LIGHT™

The auxiliary function controls the AUX power outlet on the Control Module which controls the NIGHT LIGHT™.

1. Use the Mode Key to guide you to the AUX icon.
 2. Pressing the Up Arrow Key will activate the NIGHT LIGHT™.
 3. Pressing the Down Arrow Key will turn the NIGHT LIGHT™ off.
- A single “beep” will confirm the reception of the command.

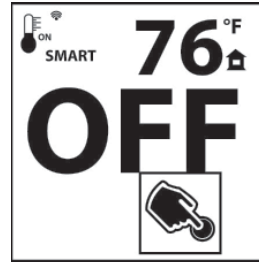

FIGURE 61



FIGURE 62

LOW BATTERY / MANUAL BYPASS

The life span of the remote batteries depends on various factors: quality of the batteries, the number of ignitions, the number of changes to the room thermostat set point, etc.

When the transmitter batteries are low, a Battery Icon will appear on the LCD display before all battery power is lost. When the batteries are replaced this icon will disappear.

When the receiver batteries are low, no “beep” will be emitted from the receiver when it receives an ON/OFF command. This is an alert for the receiver that there’s low battery. When the batteries are replaced the “beep” will be emitted from the receiver when the ON/OFF Key is pressed.

If the batteries of the receiver or transmitter are low, the appliance can be turned on manually by sliding the three position slider switch on the receiver to the “ON” position. This will bypass the remote control feature and the appliance main burner will come on if the gas valve is in the “ON” position.

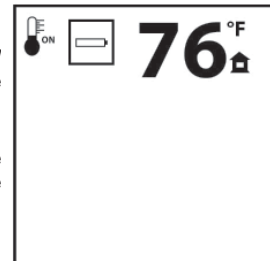

FIGURE 63

IN THE EVENT OF A POWER FAILURE

Refer to fireplace operation when communications between receiver and transmitter have been lost.

The receiver is equipped with batteries which enable the on/off or thermostat function to control the fireplace during a power failure. The blower and night light™ features will not operate during a power failure.

The receiver will emit a “beep” sound to confirm programming has been successful once power is restored.

CONTROL MODULE

Control Module (CM) offers the added ability to control the fan speed through six (6) speeds, a remotely actuated 120V AUX outlet for the night light™ and a constantly powered 120V outlet.

NOTE: Control module ON/OFF switch should always be in the “ON” position. If for any reason the module is turned OFF the components plugged into the module won’t have power.

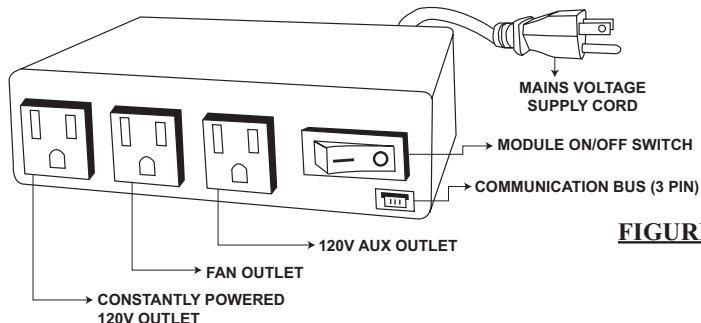

FIGURE 64

OPERATING INSTRUCTIONS

When lit for the first time, the fireplace will emit a slight odor for a few hours. This is a normal temporary condition caused by the curing of the paints and lubricants used in the manufacturing process and will not occur again. Simply open a window to sufficiently ventilate the room.

After extended periods of non-operation such as following a vacation or a warm weather season, the fireplace may emit a slight odor for a few hours. This is caused by dust particles in the heat exchanger burning off. Open a window to sufficiently ventilate the room.

Purge all gas lines with the glass door of the fireplace removed. Assure that a continuous gas flow is at the burner before installing the door.

FOR YOUR SAFETY READ BEFORE LIGHTING:

- This fireplace is equipped with a pilot which must be lit by hand while following these instructions exactly.
- Before operating smell all around the fireplace area for gas and next to the floor because some gas is heavier than air and will settle on the floor.
- Use only your hand to turn the gas control knob / manual shut-off knob. Never use tools. If the knob will not turn by hand, do not try to repair it. Call a qualified service technician. Force or attempted repair may result in a fire or explosion.
- Do not use this fireplace if any part has been under water. Immediately call a qualified service technician to inspect the fireplace and replace any part of the control system and any gas control which has been under water.

WHAT TO DO IF YOU SMELL GAS

- Do not touch any electric switch.
- Do not use any phone in your building.
- If you cannot reach your gas supplier, call the fire department.
- Turn off all gas to the fireplace.
- Do not try to light any appliance.
- Immediately call your gas supplier from a neighbor's phone. Follow the gas supplier's instructions.

WARNING: if you do not follow these instructions exactly, a fire or explosion may result causing property damage, personal injury or loss of life. Initial lighting of the pilot and main burners must be done with the glass door off.



FIGURE 65



LIGHTING INSTRUCTIONS

Do not connect valve or wall switch to electricity. See installation instructions.

When lighting and re-lighting, the gas knob cannot be turned from pilot to off unless the knob is depressed slightly.

- STOP! Read the safety information on the operating label.
- Turn off all electric power to the fireplace.
- Turn the gas knob clockwise  to off.
- Wait 5 minutes to clear out any gas. If you smell gas, including near the floor, STOP! Follow "B" on the operating label. If you don't smell gas, go to the next step.
- If the fireplace is equipped with a flame adjustment valve, turn clockwise to off.
- Find pilot located in front of the back log on the right.
- Turn gas knob counter-clockwise  to pilot.
- This unit is equipped with an auto-spark. Depress and hold gas knob. Keep knob fully depressed for one minute, then release. If pilot does not continue to burn repeat steps 3 through 7.
- With pilot lit, push and turn gas knob counter-clockwise  to on.
- If equipped with flame adjustment valve, turn knob to high.
- If equipped with remote on-off switch, main burner may not come on when you turn the valve to on or high. Remote switch must be in the on position to ignite burner.
- Turn on all electric power to the fireplace.

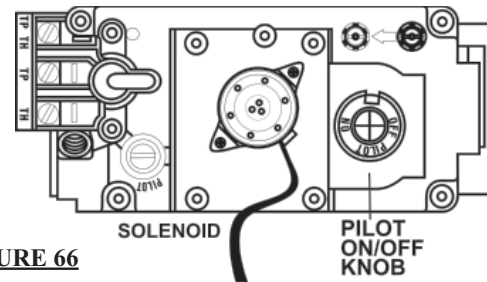



FIGURE 66

TO TURN OFF GAS

- Turn off all electric power to the fireplace if service is to be performed.
- For a complete shut-down procedure: push in gas control knob slightly and turn clockwise  to off. Do not force.
- For a temporary shut-down procedure: set the switch to off. Press and turn the gas knob clockwise  to pilot.

TURN OFF THE GAS AND ELECTRICAL POWER BEFORE SERVICING THE FIREPLACE.

ADJUSTMENTS

PILOT BURNER ADJUSTMENT

Adjust the pilot screw to provide properly sized flame. Turn in a clockwise direction to reduce the gas flow.

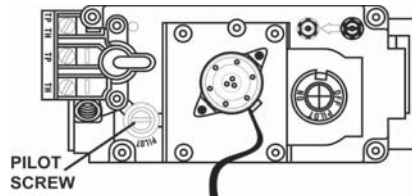

FIGURE 67

FLAME CHARACTERISTICS

It's important to periodically perform a visual check of the pilot and burner flames. Compare them to the illustrations provided.

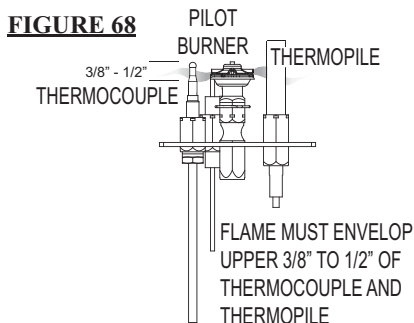

FIGURE 68



FIGURE 69

VENTURI ADJUSTMENT

Air Shutter Openings		
	Front	Rear
LP	3/8"	7/16"
NG	5/32"	3/16"

Closing the air shutter will cause a more yellow flame, but can lead to carboning. Opening the air shutter will cause a more blue flame, but can cause flame lifting from the burner ports. The flame may not appear yellow immediately; allow 15 to 30 minutes for the final flame color to be established.

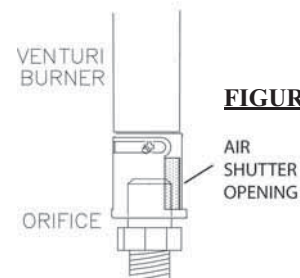

FIGURE 70

MAINTENANCE

Purge all gas lines with the glass door of the fireplace removed. Assure that a continuous gas flow is at the burner before installing the door.

TURN OFF THE GAS AND ELECTRICAL POWER BEFORE SERVICING THE FIREPLACE.

CAUTION: Label all wires prior to disconnection when servicing controls. Wiring errors can cause improper and dangerous operation. Verify proper operation after servicing. This fireplace and its venting system should be inspected before use and at least annually by a qualified service person. The fireplace area must be kept clear and free of combustible materials, gasoline or other flammable vapors and liquids. The flow of combustion and ventilation air must not be obstructed.

1. In order to properly clean the burner and pilot assembly, remove the logs to expose both assemblies.
2. Keep the control compartment, logs, burner, air shutter opening and the area surrounding the logs clean by vacuuming or brushing, *at least once a year.*

3. Check to see that all burner ports are burning. Clean out any of the ports which may not be burning or are not burning properly.
4. Check to see that the pilot flame is large enough to engulf the thermocouple and thermopile and reaches toward the burner with the third jet.
5. Replace the cleaned logs.
6. Check to see that the main burner ignites completely on all openings when the gas knob for the burner is turned on. A 5 to 10 second total light-up period is satisfactory. If ignition takes longer, consult your Authorized dealer / distributor.
7. Check that the gasket on the sides, top and bottom of the door is not broken or missing. Replace if necessary.
8. If for any reason the vent air intake system is disassembled, re-install and re-seal per the instructions provided for the initial installation.

REPLACEMENTS

Contact your dealer for questions concerning prices and availability of replacement parts. Normally all parts can be ordered through your Authorized dealer or distributor.

When ordering replacement parts always give the following information:

1. MODEL & SERIAL NUMBER OF FIREPLACE
2. INSTALLATION DATE OF FIREPLACE
3. PART NUMBER
4. DESCRIPTION OF PART
5. FINISH

REPLACEMENT PARTS

#	PART NO.	DESCRIPTION
1*	W390-0002	DOOR LATCH (EA)
2	W725-0047	NATURAL GAS VALVE - MODULATING
2	W725-0048	PROPANE GAS VALVE - MODULATING
3	W455-0040	#41 NATURAL GAS ORIFICE
3	W455-0058	#35 NATURAL GAS ORIFICE
3	W455-0059	#53 PROPANE GAS ORIFICE
4	W680-0014	THERMOCOUPLE **
5	W240-0008	ELECTRODE c/w LEAD
6	W680-0015	THERMOPILE
7	W010-1478	NATURAL GAS PILOT ASSEMBLY
7	W010-1479	PROPANE GAS PILOT ASSEMBLY
8	W455-0070	NG PILOT INJECTOR
8	W455-0068	LP PILOT INJECTOR
9*	W385-0334	NAPOLEON® LOGO
10*	W290-0116	DOOR GASKET
11	W010-1797	FIRESTOP ASSEMBLY
12	W660-0041	SPARK SWITCH
13	W660-0069	REMOTE CONTROL MODULE
14	W660-0071	REMOTE TRANSMITTER
15	W660-0070	REMOTE RECEIVER
16	W190-0017	DC SPARK UNIT CONTROL
17	W010-1480	DOOR FRAME
18*	W010-1516	GLASS c/w GASKET
19	W565-0089	SCREEN
20*	W120-0054	CURTAIN ROD CAP
21	W010-0978	PAN BURNER
22	W100-0078	TUBE BURNER
23	GL-659	LOG SET
24*	W361-0016	GLOWING EMBERS
25*	W550-0001	CHARCOAL EMBERS
26	W135-0316	REAR LOG #1
27	W135-0307	RIGHT MIDDLE LOG #2
28	W135-0308	LEFT MIDDLE LOG #3
29	W135-0311	FRONT CROSSOVER LOG #4
30	W135-0318	LEFT FRONT LOG #5
31	W135-0312	MIDDLE CROSSOVER LOG #6
32	W135-0317	RIGHT FRONT LOG #7
33	W135-0313	REAR CROSSOVER LOG #8
34	W135-0314	FRONT CHUNK #9
35	W135-0315	REAR CHUNK #10
36*	W720-0098	PILOT TUBE
37*	W361-0014	VERMICULITE
38*	W300-0067	ACCENT LIGHT GLASS
39*	W387-0006	ACCENT LIGHT
40*	W750-0107	ACCENT LIGHT WIRE
41	W290-0080	ACCENT LENSE GASKET
42*	W475-0499	PANEL REAR FIBRE
43*	W475-0493	PANEL, RIGHT FIBRE
44*	W475-0494	PANEL, LEFT FIBRE
45*	W475-0492	PANEL, BAFFLE
46*	W475-0496	HEARTH, LEFT FIBRE
47*	W475-0495	HEARTH, RIGHT FIBRE
48*	W475-0497	HEARTH, RIGHT MIDDLE
49*	W475-0498	HEARTH, LEFT MIDDLE
50*	W333-0011	HEARTH, FRONT CENTRE CONCRETE
51*	W333-0010	HEARTH, FRONT LEFT CONCRETE
52*	W333-0012	HEARTH, FRONT RIGHT CONCRETE
53*	W660-0069	CONTROL MODULE
54*	W750-0171	WIRE HARNESS
55	W135-0305	ANDIRON

! WARNING

** This is a fast acting thermocouple. It is an integral safety component. Replace only with a fast acting thermocouple supplied by Wolf Steel Ltd.

! WARNING

Failure to position the parts in accordance with these diagrams or failure to use only parts specifically approved with this appliance may result in property damage or personal injury.

* IDENTIFIES ITEMS WHICH ARE NOT ILLUSTRATED. FOR FURTHER INFORMATION, CONTACT YOUR AUTHORIZED DEALER.

FOR WARRANTY REPLACEMENT PARTS, A PHOTOCOPY OF THE ORIGINAL INVOICE WILL BE REQUIRED TO HONOUR THE CLAIM.

FLEXIBLE VENT KITS

GD620 (5 FT)

56*	W010-0772	8" FLEXIBLE ALUMINIUM LINER - (5 FT) c/w SPACERS
56*	W730-0026	10" FLEXIBLE ALUMINIUM LINER - (5 FT)

GD630 (10 FT)

56*	W730-0027	10" FLEXIBLE ALUMINIUM LINER - (10 FT)
56*	W010-0773	8" FLEXIBLE ALUMINIUM LINER - (10 FT) c/w SPACERS
57*	W010-0810	WALL SUPPORT ASSEMBLY

HORIZONTAL TERMINAL KIT

58	GD622R	WALL TERMINAL KIT
----	--------	-------------------

ROOF TERMINAL KITS

59*	GD610	1/12 TO 7/12 PITCH
60*	GD611	8/12 TO 12/12 PITCH
61*	GD612	FLAT ROOF
62	W490-0075	8/10 INNER OUTER SLEEVE
63	W670-0008	8/10 TERMINAL
64	W170-0016	STORM COLLAR
65	W010-0453	ROOF SUPPORT
66	W263-0083	ROOF FLASHING 1/12 - 7/12 PITCH
	W263-0084	ROOF FLASHING 8/12 - 12/12 PITCH

ACCESSORIES

67*	W573-0007	HI-TEMP SEALANT
68*	GD501	HEAT GUARD
69	GA-566	HOT AIR DISTRIBUTION KIT
70	GA-72	HOT AIR EXHAUST KIT
71	GA-70	EXTENSION KIT, 5FT FLEX VENT
72*	W010-0370	WALL SUPPORT ASSEMBLY
73*	W175-0249	10" COUPLER
74*	W175-0002	8" COUPLER
75*	W175-0260	CONVERSION KIT - NG TO LP
75*	W175-0261	CONVERSION KIT - LP TO NG
76*	CP90	CRANE AND POT
77*	F90SA	DECORATIVE FRAME-SQUARE "ARTSAN"
78*	DK90RA	RECTANGULAR DOUBLE DOORS "ARTISAN"
79	W585-0222	VENT PIPE SHIELD
80*	W170-0116	10" STORM COLLAR
81*	NZ64	BLOWER KIT
82*	GA65	10' FLEX WITH 6" COLLAR (FOR USE WITH NZ64)

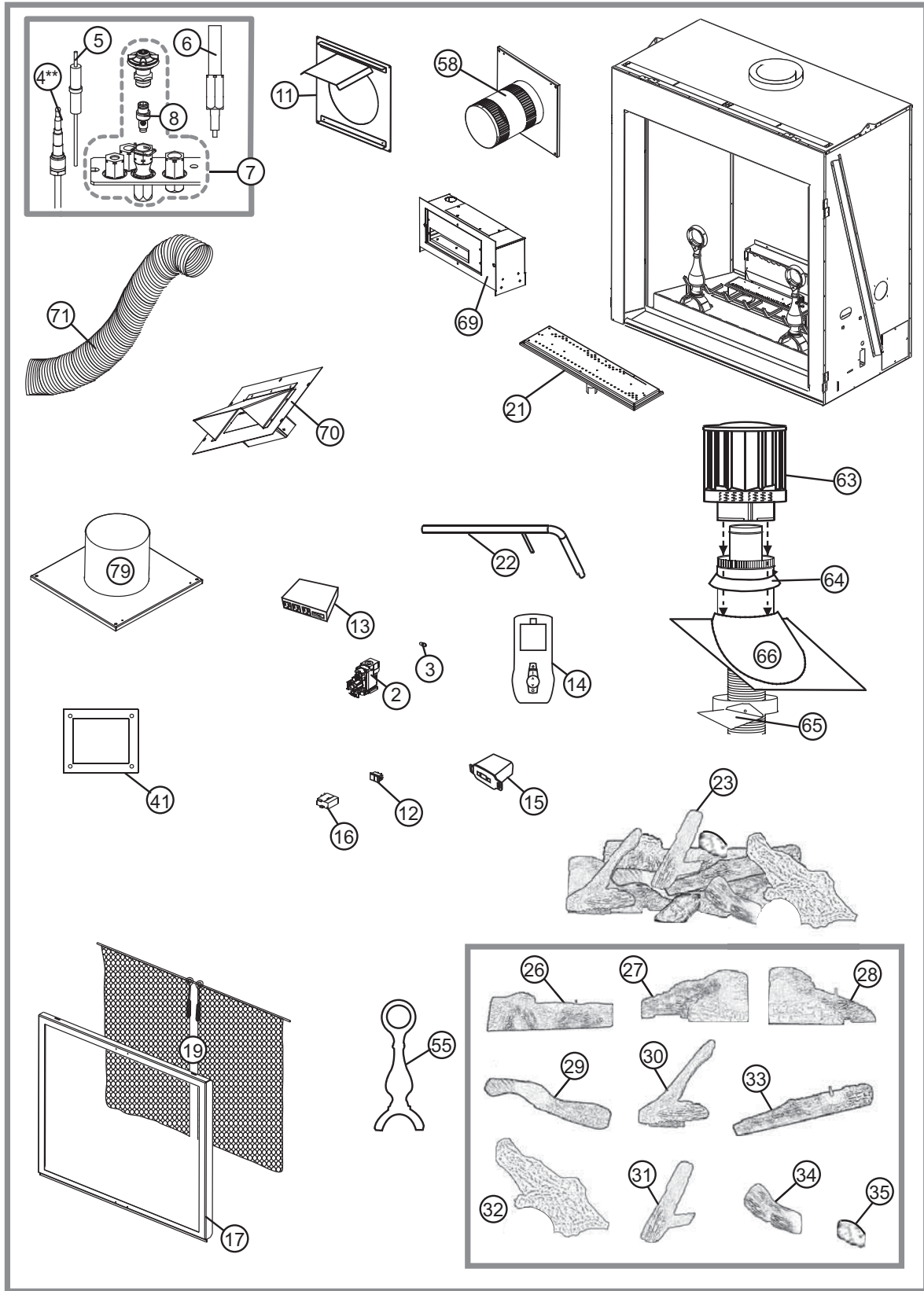

TROUBLE SHOOTING GUIDE

BEFORE ATTEMPTING TO TROUBLESHOOT, PURGE YOUR UNIT AND INITIALLY LIGHT THE PILOT AND THE MAIN BURNER WITH THE GLASS DOOR OPEN.

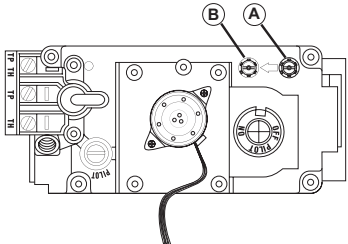
SYMPTOM	PROBLEM	TEST SOLUTION
Main burner flame is a blue, lazy, transparent flame.	Blockage in vent. <hr/> Incorrect installation.	- remove blockage. In really cold conditions, ice buildup may occur on the terminal and should be removed as required. <hr/> - refer to Figure 13 to ensure correct location of storm collars.
Flames are consistently too large or too small. Carboning occurs.	Unit is over-fired or under-fired.	- check pressure readings: Inlet pressure can be checked by turning screw (A) counter-clockwise 2 or 3 turns and then placing pressure gauge tubing over the test point. Gauge should read 7" (minimum 4.5") water column for natural gas or 13" (11" minimum) water column for propane. Check that main burner is operating on "HI". Outlet pressure can be checked the same as above using screw (B). Gauge should read 3.5" water column for natural gas or 10" water column for propane. Check that main burner is operating on "HI". AFTER TAKING PRESSURE READINGS, BE SURE TO TURN SCREWS CLOCKWISE FIRMLY TO RESEAL. DO NOT OVERTORQUE. Leak test with a soap and water solution.
		
Carbon is being deposited on glass, logs or combustion chamber surfaces.	Air shutter has become blocked <hr/> Flame is impinging on the logs or combustion chamber.	- ensure air shutter opening is free of lint or other obstructions. <hr/> - check that the logs are correctly positioned. - open air shutter to increase the primary air. - check the input rate: check the manifold pressure and orifice size as specified by the rating plate values. - check that the door gasket is not broken or missing and that the seal is tight. - check that both 8" and 10" vent liners are free of holes and well sealed at all joints. - check that minimum rise per foot has been adhered to for any horizontal venting.
White / grey film forms.	Sulphur from fuel is being deposited on glass, logs or combustion chamber surfaces.	- clean the glass with a gas fireplace glass cleaner. DO NOT CLEAN GLASS WHEN HOT. If deposits are not cleaned off regularly, the glass may become permanently marked.
Exhaust fumes smelled in room, headaches.	Fireplace is spilling.	- check door seal and relief flap seal. - check for chimney blockage - check that the paint curing process is complete
Pilot goes out when the gas knob is released.	System is not correctly purged.	- purge the gas line with the glass door open.
The gas valve has an interlock device which will not allow the pilot burner to be lit until the thermocouple has cooled. Allow approximately 60 seconds for the thermocouple to cool.	Out of propane gas.	- fill the tank.
	Pilot flame is not large enough	- turn up the pilot flame.
	Pilot flame is not engulfing the thermocouple.	- gently twist the pilot head to improve the flame pattern around the thermocouple.
	Thermocouple shorting / faulty.	- loosen and tighten thermocouple. - clean thermocouple and valve connection. - replace thermocouple. - replace valve.
	Faulty valve.	- replace.

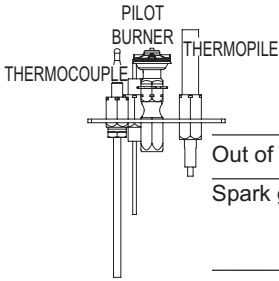
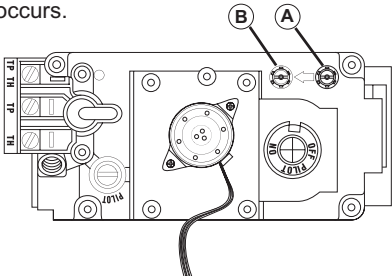
SYMPTOM	PROBLEM	TEST SOLUTION
Pilot burning; no gas to main burner; Flame height is on 'HI'; Remote and transmitter ON	Remote receiver	- disconnect switch wires & connect a jumper wire across terminals 1 & 3; if the main burner lights, check the wires for defects and / or replace wires.
	Main burner orifice is plugged.	- remove stoppage in orifice.
	Faulty thermopile.	- test and replace if required.
Pilot goes out while standing; Main burner is in 'OFF' position.	Gas piping is undersized.	- turn on all gas appliances and see if pilot flame flutters, diminishes or extinguishes, especially when main burner ignites. Monitor appliance supply working pressure. - check if supply piping size is to code. Correct all undersized piping.
Pilot will not light. 	No spark at pilot burner	- check if pilot can be lit by a match - check that the wire is connected to the spark module. - check batteries. - replace the wire if the wire insulation is broken or frayed. - replace the electrode if the ceramic insulator is cracked or broken. - replace spark module.
	Out of propane gas	- fill the tank.
	Spark gap is incorrect	- spark gap should be 0.150" to 0.175" (5/32" to 11/64" approx.) from the electrode tip and the pilot burner. To ensure proper electrode location, tighten securing nut (finger tight plus 1/4 turn).
	No gas at the pilot burner	- check that the manual valve is turned on. - check the pilot orifice for blockage. - call the gas distributor.
	Main burner goes out; pilot stays on.	Pilot flame is not large enough or not engulfing the thermopile - turn up pilot flame. - replace pilot assembly.
	Thermopile shorting	- clean thermopile connection to the valve. Reconnect. - test and replace thermopile if required.
	Temperature setting on transmitter is satisfied	- turn up temperature setting.
Main burner goes out; pilot goes out.	Refer to "MAIN BURNER GOES OUT; PILOT STAYS ON"	
	Vent is blocked	- check for vent blockage.
	Vent is re-circulating	- check joint seals and installation.
Flames are consistently too large or too small. Carboning occurs.	8" flexible vent has become disconnected from fireplace.	- re-attach to fireplace.
	Unit is over-fired or under-fired.	- check pressure readings: Inlet pressure can be checked by turning screw (A) counter-clockwise 2 or 3 turns and then placing pressure gauge tubing over the test point. Gauge should read 7" (minimum 4.5") water column for natural gas or 13" (11" minimum) water column for propane. Check that main burner is operating on "HI". Outlet pressure can be checked the same as above using screw (B). Gauge should read 3.5" water column for natural gas or 10" water column for propane. Check that main burner is operating on "HI". AFTER TAKING PRESSURE READINGS, BE SURE TO TURN SCREWS CLOCKWISE FIRMLY TO RESEAL. DO NOT OVERTORQUE. Leak test with a soap and water solution.
		

WOLF STEEL Fireplace Service History

This fireplace must be serviced annually depending on usage

DATE	DEALER NAME	SERVICE TECHNICIAN NAME	SERVICE PERFORMANCE	SPECIAL CONCERNS

