

INSTALLER: THESE INSTRUCTIONS MUST BE CONVEYED TO AND REMAIN WITH THE HOMEOWNER.



INSTALLATION AND OPERATION INSTRUCTIONS

CERTIFIED UNDER CANADIAN AND AMERICAN NATIONAL STANDARDS: CSA 2.33, ANSI Z21.88 FOR VENTED GAS FIREPLACES HEATERS.

BGD42N
NATURAL GAS

BGD42P
PROPANE

CERTIFIED FOR CANADA AND UNITED STATES USING ANSI/CSA METHODS.

SAFETY INFORMATION

WARNING: If the information in these instructions are not followed exactly, a fire or explosion may result causing property damage, personal injury or loss of life.

- Do not store or use gasoline or other flammable vapors and liquids in the vicinity of this or any other appliance.
- **WHAT TO DO IF YOU SMELL GAS:**
 - Do not try to light any appliance.
 - Do not touch any electrical switch; do not use any phone in your building.
 - Immediately call your gas supplier from a neighbour's phone. Follow the gas supplier's instructions.
 - If you cannot reach your gas supplier, call the fire department.
- Installation and service must be performed by a qualified installer, service agency or the supplier.



APPLY SERIAL NUMBER LABEL FROM CARTON



Serial No. X X X X X 0 0 0 0 0 0
MODEL NO.

Wolf Steel Ltd., 24 Napoleon Rd., Barrie, ON L4M 4Y8 Canada • (705)721-1212 • fax(705)722-6031
www.napoleonfireplaces.com • ask@napoleon.on.ca

BGD42 TABLE of CONTENTS

<p>PG 2-4 INTRODUCTION Warranty General Instructions General Information Care of Glass & Plated Parts Installation Overview</p> <p>6 - 13 VENTING Venting Lengths Air Terminal Locations Typical Vent Installations Special Vent Installations</p> <p>14 - 20 INSTALLATION Wall and ceiling protection Horizontal Installation Adjustable Firestop Vertical Installation Wall and Ceiling Protection Using Flexible Vent Components Fireplace Vent Connection Using Rigid Vent Components Restricting Vertical Vents Gas Installation Optional Wall Switch Installation Mobile Home Installation Framing Nailing Tab Installation Minimum Mantel and Enclosure Clearances</p>	<p>20-22 FINISHING Door, Louvre & Panel Removal & Installation Grate Installation Log Placement / Glowing Embers Vermiculite Charcoal Embers Charcoal Lumps</p> <p>22 OPTIONAL BLOWER INSTALLATION</p> <p>22-23 OPTIONAL FAN INSTALLATION / GD36 THERMOSTATIC SENSOR CONTROL</p> <p>23 OPERATION / MAINTENANCE Operating Instructions Maintenance</p> <p>24 ADJUSTMENTS Pilot Burner Adjustment Venturi Adjustment</p> <p>25-26 REPLACEMENTS Ordering Replacement Parts Replacement Parts Vent Kits Terminal Kits Accessories</p> <p>27-28 TROUBLE SHOOTING GUIDE</p>
--	--

PLEASE RETAIN THIS MANUAL FOR FUTURE REFERENCE

WARNING

- Do not burn wood or other materials in this fireplace.
- Adults and especially children should be alerted to the hazards of high surface temperatures and should stay away to avoid burns or clothing ignition. Supervise young children when they are in the same room as the fireplace.
- Clothing or other flammable material should not be placed on or near the fireplace.
- Due to high temperatures, the fireplace should be located out of traffic and away from furniture and draperies.
- Ensure you have incorporated adequate safety measure to protect infants/toddlers from touching hot surfaces.
- Even after the fireplace is out, the glass and/or screen will remain hot for an extended period of time.
- Check with your local hearth specialty dealer for safety screens and hearth guards to protect children from hot surfaces. These screens and guards must be fastened to the floor.
- Any safety screen or guard removed for servicing must be replaced prior to operating the fireplace.
- It is imperative that the control compartments, burners and circulating blower and its passageway in the fireplace and venting system are kept clean. The fireplace and its venting system should be inspected before use and at least annually by a qualified service person. More frequent cleaning may be required due to excessive lint from carpeting, bedding material, etc. The fireplace area must be kept clear and free from combustible materials, gasoline and other flammable vapours and liquids.
- Under no circumstances should this fireplace be modified.
- This fireplace must not be connected to a chimney flue pipe serving a separate solid fuel burning appliance.
- Do not use this fireplace if any part has been under water. Immediately call a qualified service technician to inspect the fireplace and to replace any part of the control system and any gas control which has been under water.
- Do not operate the fireplace with the glass door removed, cracked or broken. Replacement of the glass should be done by a licensed or qualified service person.
- Do not strike or slam shut the fireplace glass door.
- This fireplace uses and requires a fast acting thermocouple. Replace only with a fast acting thermocouple supplied by Wolf Steel Ltd.
- Pressure relief doors must be kept closed while the fireplace is operating to prevent exhaust fumes containing carbon monoxide, from entering into the home. Temperatures of the exhaust escaping through these openings can also cause the surrounding combustible materials to overheat and catch fire.
- Only doors / optional fronts certified with the unit are to be installed on the appliance.

NOTE: changes, other than editorial, are denoted by a vertical line in the margin.

W415-0381 / H / 12.07.07

NAPOLEON® products are manufactured under the strict Standard of the world recognized ISO 9001 : 2000 Quality Assurance Certificate.

NAPOLEON® products are designed with superior components and materials, assembled by trained craftsmen who take great pride in their work. The burner and valve assembly are leak and test-fired at a quality test station. Once assembled the complete fireplace is thoroughly inspected by a qualified technician before packaging to ensure that you, the customer, receives the quality product that you expect from NAPOLEON®.

NAPOLEON® GAS FIREPLACE PRESIDENT'S LIFETIME LIMITED WARRANTY

The following materials and workmanship in your new NAPOLEON® gas fireplace are warranted against defects for as long as you own the fireplace. This covers: combustion chamber, heat exchanger, stainless steel burner, phazer™ logs and embers, ceramic glass (thermal breakage only), gold plated parts against tarnishing, porcelainized enamelled components and aluminum extrusion trims.

Electrical (110V and millivolt) components and wearable parts such as blowers, gas valves, thermal switch, switches, wiring, remote controls, ignitor, gasketing, and pilot assembly are covered and NAPOLEON® will provide replacement parts free of charge during the first year of the limited warranty.

Labour related to warranty repair is covered free of charge during the first year. Repair work, however, requires the prior approval of an authorized company official. Labour costs to the account of NAPOLEON® are based on a predetermined rate schedule and any repair work must be done through an authorized NAPOLEON® dealer.

CONDITIONS AND LIMITATIONS

NAPOLEON® warrants its products against manufacturing defects to the original purchaser only -- i.e., the individual or legal entity (registered customer) whose name appears on the warranty registration card filed with NAPOLEON® -- provided that the purchase was made through an authorized NAPOLEON® dealer and is subject to the following conditions and limitations:

This factory warranty is nontransferable and may not be extended whatsoever by any of our representatives.

The gas fireplace must be installed by a licensed, authorized service technician or contractor. Installation must be done in accordance with the installation instructions included with the product and all local and national building and fire codes.

This limited warranty does not cover damages caused by misuse, lack of maintenance, accident, alterations, abuse or neglect and parts installed from other manufacturers will nullify this warranty.

This limited warranty further does not cover any scratches, dents, corrosion or discolouring caused by excessive heat, abrasive and chemical cleaners nor chipping on porcelain enamel parts, mechanical breakage of PHAZER™ logs and embers, nor any venting components used in the installation of the fireplace.

NAPOLEON® warrants its stainless steel burners against defects in workmanship and material for life, subject to the following conditions: During the first 10 years NAPOLEON® will replace or repair the defective parts at our option free of charge. From 10 years to life, NAPOLEON® will provide replacement burners at 50% of the current retail price.

In the first year only, this warranty extends to the repair or replacement of warranted parts which are defective in material or workmanship provided that the product has been operated in accordance with the operation instructions and under normal conditions.

After the first year, with respect to this President's Limited Lifetime Warranty, NAPOLEON® may, at its discretion, fully discharge all obligations with respect to this warranty by refunding to the original warranted purchaser the wholesale price of any warranted but defective part(s).

After the first year, NAPOLEON® will not be responsible for installation, labour or any other costs or expenses related to the reinstallation of a warranted part, and such expenses are not covered by this warranty.

Notwithstanding any provisions contained in this President's Limited Lifetime Warranty, NAPOLEON'S responsibility under this warranty is defined as above and it shall not in any event extend to any incidental, consequential or indirect damages.

This warranty defines the obligations and liability of NAPOLEON® with respect to the NAPOLEON® gas fireplace and any other warranties expressed or implied with respect to this product, its components or accessories are excluded.

NAPOLEON® neither assumes, nor authorizes any third party to assume, on its behalf, any other liabilities with respect to the sale of this product. NAPOLEON® will not be responsible for: over-firing, downdrafts, spillage caused by environmental conditions such as rooftops, buildings, nearby trees, hills, mountains, inadequate vents or ventilation, excessive venting configurations, insufficient makeup air, or negative air pressures which may or may not be caused by mechanical systems such as exhaust fans, furnaces, clothes dryers, etc.

Any damages to fireplace, combustion chamber, heat exchanger, brass trim or other component due to water, weather damage, long periods of dampness, condensation, damaging chemicals or cleaners will not be the responsibility of NAPOLEON®.

The bill of sale or copy will be required together with a serial number and a model number when making any warranty claims from your authorized dealer. The warranty registration card must be returned within fourteen days to register the warranty.

NAPOLEON® reserves the right to have its representative inspect any product or part thereof prior to honouring any warranty claim.

GENERAL INSTRUCTIONS

THIS GAS FIREPLACE SHOULD BE INSTALLED AND SERVICED BY A QUALIFIED INSTALLER to conform with local codes. In absence of local codes, install the **BGD42** to the current National Fuel Gas Code, ANSI Z223.1, or the current CAN/CGA B149, Installation Codes.

Installation practices vary from region to region and it is important to know the specifics that apply to your area,

for example: in Massachusetts State:

- The fireplace damper must be removed or welded in the open position prior to installation of a fireplace insert or gas log.
- The appliance off valve must be a "T" handle gas cock.
- The flexible connector must not be longer than 36".
- The appliance is not approved for installation in a bedroom or bathroom unless the unit is a direct vent sealed combustion product.
- **WARNING:** This product must be installed by a licensed plumber or gas fitter when installed within the commonwealth of Massachusetts.

Mobile home installation must conform with local codes or in the absence of local codes, install to the current standard for gas equipped mobile housing CAN/CSA ZA240 MH Series in Canada or the Manufactured Home Construction and Safety Standard, Title 24 CFR, Part 3280, or the Fire Safety Criteria for Manufactured Home Installations, Sites and Communities Standard ANSI/NFPA 501A in the United States.

The fireplace and its individual shutoff valve must be disconnected from the gas supply piping system during any pressure testing of that system at test pressures in excess of 1/2 psig (3.5 kPa). The fireplace must be isolated from the gas supply piping system by closing its individual manual shutoff valve during any pressure testing of the gas supply piping system at test pressures equal to or less than 1/2 psig (3.5 kPa).

When the fireplace is installed directly on carpeting, vinyl tile or other combustible material other than wood flooring, the fireplace shall be installed on a metal or wood panel extending the full width and depth.

If the optional fan or blower is installed, the junction box must be electrically connected and grounded in accordance with local codes. In the absence of local codes, use the current CSA C22.1 CANADIAN ELECTRICAL CODE in Canada or the ANSI/NFPA 70 NATIONAL ELECTRICAL CODE in the United States.

GENERAL INFORMATION

FOR YOUR SATISFACTION, THIS FIREPLACE HAS BEEN TEST-FIRED TO ASSURE ITS OPERATION AND QUALITY! Maximum input is 28,500 BTU/hr for natural gas and 24,000 BTU/hr for propane. When the fireplace is installed at elevations above 4,500ft, and in the absence of specific recommendations from the local authority having jurisdiction, the certified high altitude input rating shall be reduced at the rate of 4% for each additional 1,000ft.

Maximum output for natural gas is 19,500 BTU/hr at an efficiency of 68.5% with the fan on, and 16,000 BTU/hr for propane at an efficiency of 67% with the fan on. The maximum A.F.U.E. (annual fuel utilization efficiency) rating is 64% for natural gas and 61.5% for propane.

Minimum inlet gas supply pressure is 4.5" water column for natural gas and 11" water column for propane. Maximum inlet gas pressure is 7" water column for natural gas and 13" water column for propane. Manifold pressure under flow conditions is 3.5" water column for natural gas and 10" water column for propane.

This fireplace is approved for bathroom, bedroom and bed-sitting room installations and is suitable for mobile home installation.

No external electricity (110 volts or 24 volts) is required for the gas system operation.

Expansion / contraction noises during heating up and cooling down cycles are normal and are to be expected.



We suggest that our gas hearth products be installed and serviced by professionals who are certified in the U.S. by the National Fireplace Institute® (NFI) as NFI Gas Specialists.

CARE OF GLASS, AND PLATED PARTS

Do not use abrasive cleaners to clean plated parts. Buff lightly with a clean dry cloth. The BGD42 is factory equipped with tempered glass. The glass thickness is 3/16". Use only replacement glass available from your Napoleon® dealer. **DO NOT SUBSTITUTE MATERIALS.** Clean the glass after the first 10 hours of operation with a recommended gas fireplace glass cleaner. Thereafter clean as required. **DO NOT CLEAN GLASS WHEN HOT!** If the glass is not kept clean permanent discoloration and / or blemishes may result.

Use only accessories designed for and listed with your specific fireplace.

Provide adequate ventilation air. Provide adequate accessibility clearance for servicing and operating the fireplace. Never obstruct the front opening of the fireplace.

For safe and proper operation of the fireplace follow the venting instruction exactly.

Deviation from the minimum vertical vent length can create difficulty in burner start-up and/or carboning.

Provide a means for visually checking the vent connection to the fireplace after the fireplace is installed.

In order to avoid the possibility of exposed insulation or vapour barrier coming in contact with the fireplace body, it is recommended that the walls of the fireplace enclosure be 'finished', (i.e. drywall/sheetrock) as would any other outside wall of the home. This will ensure that clearance to combustibles is maintained within the cavity.

Vent lengths that pass through unheated spaces (attics, garages, crawl spaces) should be insulated with the insulation wrapped in a protective sleeve to minimize condensation.

Objects placed in front of the fireplace must be kept a minimum of 48" away from the front face of the unit.

WARNING



**HOT GLASS WILL CAUSE BURNS.
DO NOT TOUCH GLASS UNTIL COOLED.
NEVER ALLOW CHILDREN TO TOUCH GLASS.**

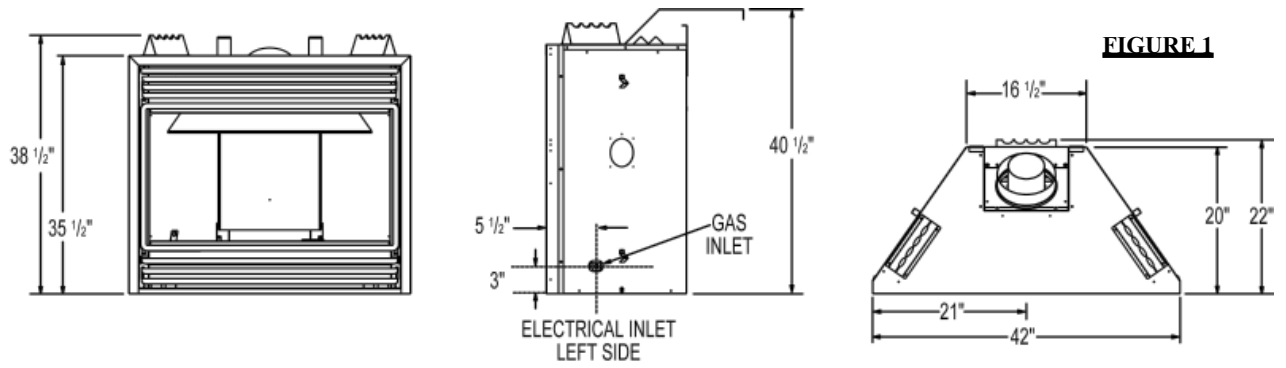

FIGURE 1

INSTALLATION OVERVIEW

See the section
"MINIMUM MANTEL AND
ENCLOSURE CLEARANCES"

See the section
"FRAMING" and
"MINIMUM MANTEL
AND ENCLOSURE
CLEARANCES" for
drywall (or other
combustible material)

See the section
"Framing"

Side
Wall

See the sections
"VENTING" and
"INSTALLATION"

See the section
"INSTALLATION - FRAMING"

FIGURE 2

VENTING

VENTING LENGTHS

Use only Wolf Steel, Simpson Dura-Vent, *Selkirk Direct Temp* or *American Metal Amerivent* venting components. Minimum and maximum vent lengths, for both horizontal and vertical installations, and air terminal locations for either system are set out in this manual and must be adhered to. For Simpson Dura-Vent, Selkirk Direct Temp and American Metal Amerivent, follow the installation procedure provided with the venting components.

All outer pipe joints of these venting systems must be sealed using Red RTV High Temperature Sealant.

Wolf Steel, Simpson Dura-Vent, Selkirk Direct Temp and American Metal Amerivent venting systems must not be combined.

A starter adaptor must be used and may be purchased from the corresponding supplier:

Supplier	4&7 ZC 5&8 ZC GAS STOVE		
Dura-Vent	W175-0053	W175-0170	GDS924N
Amerivent	4DSC-N2	5DSC-N	4DSCB-N1
Direct Temp	4DT-AAN	5DT-AA	4DT-AAN

For Simpson Dura-Vent, Selkirk Direct Temp and American Metal Amerivent, follow the installation procedure found on the website for your venting supplier:

VENTING SUPPLIER	WEBSITE ADDRESS
Simpson Dura-Vent	www.duravent.com
Selkirk Direct Temp	www.selkirkcorp.com
American Metal Amerivent	www.americanmetalproducts.com

For vent systems that provide seals on the inner exhaust flue, only the outer air intake joints must be sealed using a red high temperature silicone (RTV). This same sealant may be used on both the inner exhaust and outer intake vent pipe joints of all other approved vent systems except for the exhaust vent pipe connection to the fireplace flue collar which must be sealed using the black high temperature sealant W573-0007 (not supplied) Mill Pac.

When using Wolf Steel venting components, use only approved Wolf Steel rigid / flexible components with the following termination kits: WALL TERMINAL KIT **GD422**, or 1/12 TO 7/12 PITCH ROOF TERMINAL KIT **GD410**, 8/12 TO 12/12 ROOF TERMINAL KIT **GD411**, FLAT ROOF TERMINAL KIT **GD412** or PERISCOPE KIT **GD401** (for wall penetration below grade). With flexible venting, in conjunction with the various terminations, use either the 5 foot vent kit **GD420** or the 10 foot vent kit **GD430**.

These vent kits allow for either horizontal or vertical venting of the fireplace. **FIGURES 3 & 5**. The maximum allowable horizontal run is 20 feet. The maximum allowable vertical vent length is 40 feet. The maximum number of 5" vent

The air terminal must remain unobstructed at all times. Examine the air terminal at least once a year to verify that it is unobstructed and undamaged.

Purge all gas lines with the glass door of the fireplace removed. Assure that a continuous gas flow is at the burner before re-installing the door.

Under extreme vent configurations, allow several minutes (5-15) for the flame to stabilize after ignition.

A terminal shall not terminate directly above a sidewalk or paved driveway which is located between two single family dwellings and serves both dwellings. Local codes or regulations may require different clearances.

Do not allow the inside liner to bunch up on horizontal or vertical runs and elbows. Keep it pulled tight. A 1/4" air gap all around between the inner liner and outer liner is required for safe operation. Use a firestop when penetrating interior walls, floor or ceiling.

Minimum clearance to combustible construction from fireplace and vent surfaces:

Sides, back, bottom and top of the unit	0"
Recessed depth	22"
All around the vent pipe*	2"
Enclosure top	45 1/2"
Ceiling	72" from bottom of unit

***HORIZONTAL VENT SECTIONS:** A minimum clearance of 2" all around the vent pipe on all horizontal runs to combustibles is required. Use firestop spacer W010-1778 (supplied).

VERTICAL VENT SECTIONS: A minimum of 1" all around the vent pipe on all vertical runs to combustibles is required except for clearances in fireplace enclosures. Use firestop spacer W500-0367 (not supplied).

Horizontal runs may have a 0" rise per foot in all cases using SIMPSON DURA-VENT, SELKIRK DIRECT TEMP, AMERICAN METAL AMERIVENT or NAPOLEON RIGID OR FLEXIBLE venting components when venting as illustrated in Figures 3, and 4.

For optimum performance it is recommended that all horizontal runs have a 1" rise per foot when using Napoleon® flexible vent components.

MINIMUM AIR TERMINAL LOCATION CLEARANCES

FIGURE 3

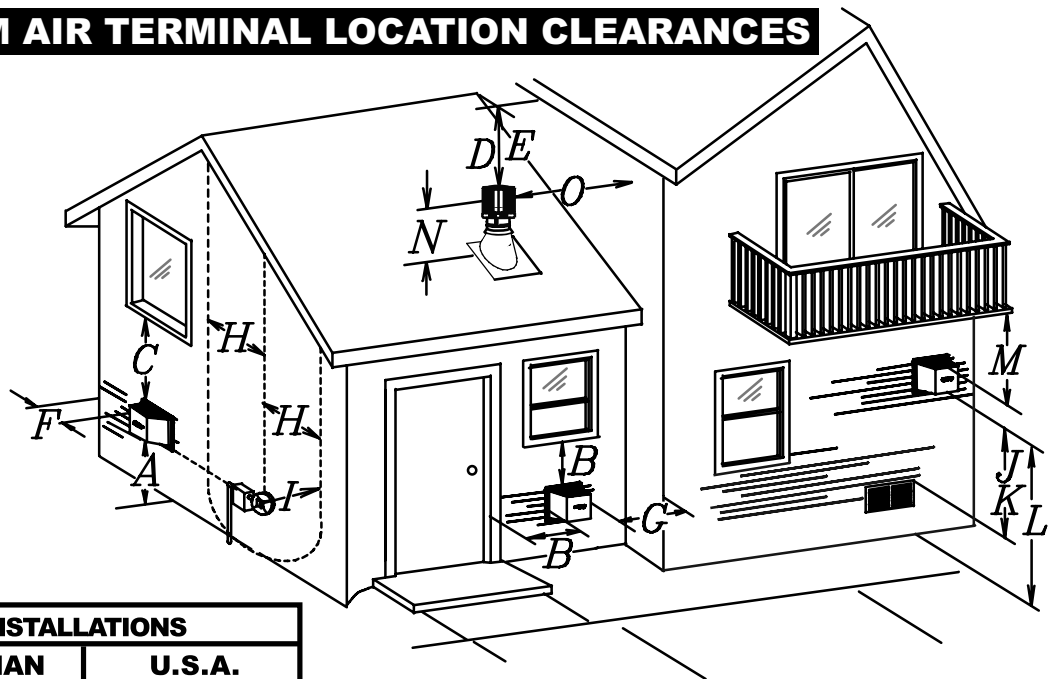

	INSTALLATIONS		
	CANADIAN	U.S.A.	
A	12 INCHES	12 INCHES	Clearance above grade, veranda porch, deck or balcony.
B	12 INCHES	9 INCHES	Clearance to windows or doors that open.
C	12 INCHES*	12 INCHES*	Clearance to permanently closed windows.
D	32 INCHES**	32 INCHES**	Vertical clearance to ventilated soffit located above the terminal within a horizontal distance of 2 feet from the centerline of the terminal.
E	32 INCHES**	32 INCHES**	Clearance to unventilated soffit.
F	0 INCHES	0 INCHES	Clearance to an outside corner wall.
G	0 INCHES***	0 INCHES***	Clearance to an inside <i>non</i> -combustible corner wall or protruding <i>non</i> -combustible obstructions (chimney, etc.).
	2 INCHES***	2 INCHES***	Clearance to an inside combustible corner wall or protruding combustible obstructions (vent chase, etc.).
H	3 FEET	3 FEET****	Clearance to each side of the centerline extended above the meter / regulator assembly to a maximum vertical distance of 15ft.
I	3 FEET	3 FEET****	Clearance to a service regulator vent outlet.
J	12 INCHES	9 INCHES	Clearance to a non-mechanical air supply inlet to the building or a combustion air inlet to any other appliance.
K	6 FEET	3 FEET†	Clearance to a mechanical air supply inlet.
L	7 FEET‡	7 FEET****	Clearance above a paved sidewalk or paved driveway located on public property unless fitted with a heat shield kit GD-301.
M	32 INCHES††	32 INCHES****	Clearance under a veranda, porch, deck or balcony. **
N	16 INCHES	16 INCHES	Clearance above the roof.
O	2 FEET†*	2 FEET†*	Clearance from an adjacent wall including neighbouring buildings.

* Recommended to prevent condensation on windows and thermal breakage

** Using a soffit heat shield (W585-0096), or equivalent, the distance may be reduced to a minimum of 18". It is recommended to maximize the distance to the vinyl clad soffits.

*** The periscope GD-401 requires a minimum 18 inches clearance from an inside corner.

**** This is a recommended distance. For additional requirements check local codes.

† 3 feet above if within 10 feet horizontally.

‡ A vent shall not terminate directly above a sidewalk or paved driveway that is located between two single family dwellings and serves both dwellings.

†† Permitted only if the veranda, porch, or deck is fully open on a minimum of two sides beneath the floor.

†* Recommended to prevent recirculation of exhaust products. For additional requirements check local codes.

TYPICAL VENT INSTALLATIONS

NOTE: When terminating vertically, the restrictor plate W500-0205 must be installed. Refer to Restricting Vertical Vents.

FIGURES 4 a-b

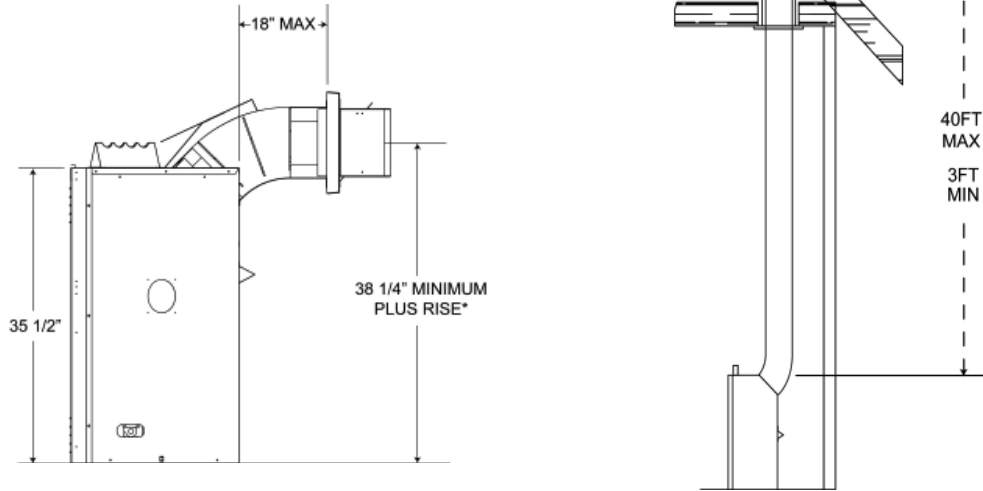

* See venting section

SPECIAL VENT INSTALLATIONS

PERISCOPE TERMINATION

Use the GD401 periscope kit to locate the air termination above grade. The periscope must be installed so that when final grading is completed, the bottom air slot is located a minimum of 12" above grade.

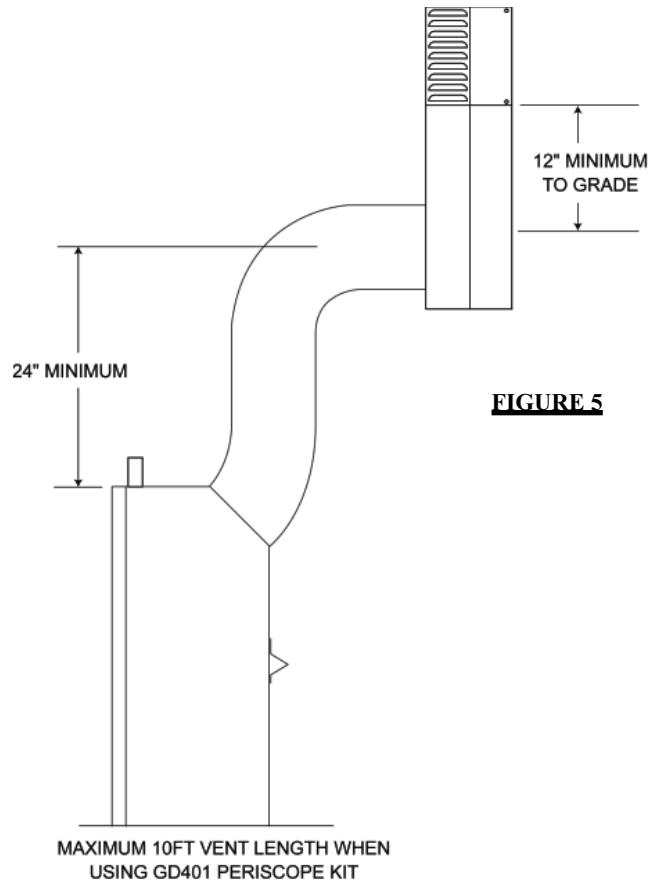
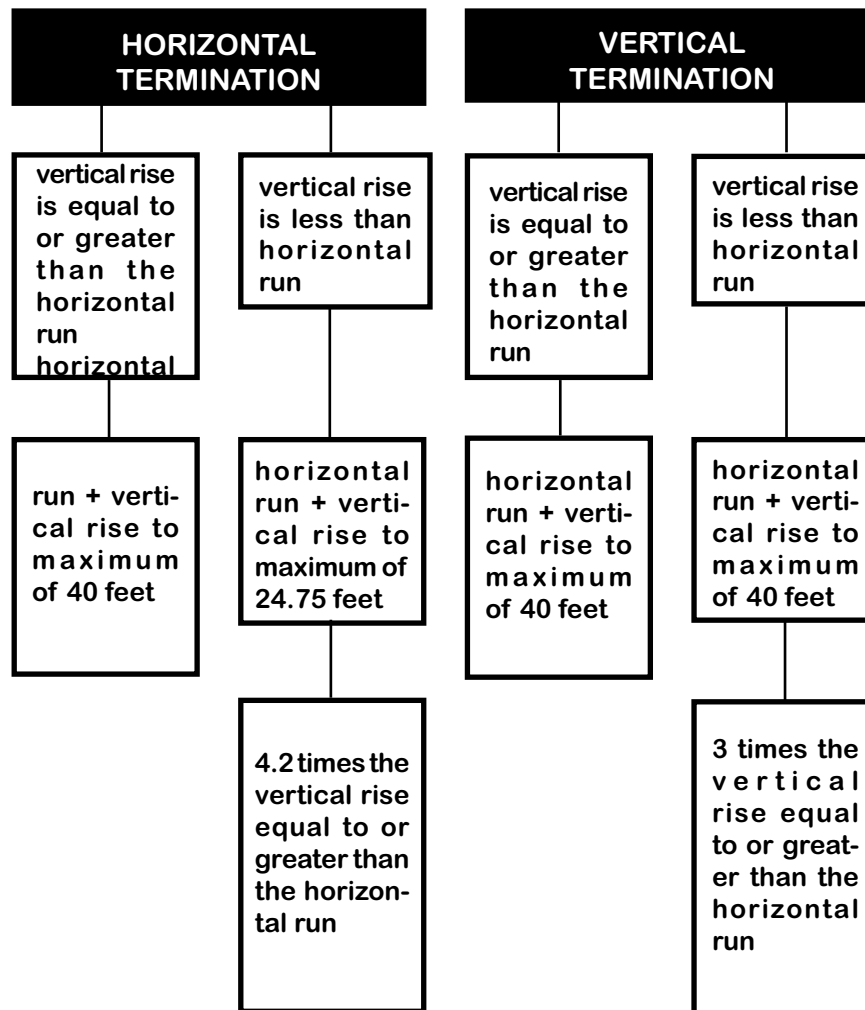

FIGURE 5

VENTING APPLICATION FLOW CHART



DEFINITIONS

for the following symbols used in the venting calculations and examples are:

- > - greater than
- ≥ - equal to or greater than
- < - less than
- ≤ - equal to or less than
- H_T** - total of both horizontal vent lengths (**H_R**) and offsets (**H_O**) in feet
- H_R** - combined horizontal vent lengths in feet
- H_O** - offset factor: .03(total degrees of offset - 135°) in feet
- V_T** - combined vertical vent lengths in feet

ELBOW VENT LENGTH VALUES

	<u>feet</u>	<u>inches</u>
1°	0.03	0.5
15°	0.45	6.0
30°	0.9	11.0
45°*	1.35	16.0
90°*	2.7	32.0

* the first 45° and 90° offset has a zero value and is shown in the formula as **-45°** and **-90°** respectively or **-135°** when combined.

HORIZONTAL TERMINATION

when (**H_T**) ≤ (**V_T**)

Simple venting configuration (only one 45° and 90° elbow)

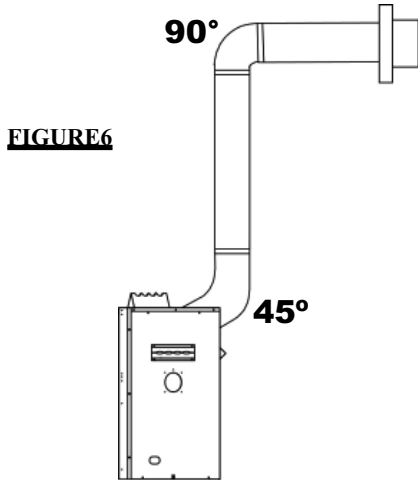

FIGURE 6

For vent configurations requiring more than one 45° and 90° elbow, the following formulas apply:

Formula 1: H_T ≤ V_T

Formula 2: H_T + V_T ≤ 40 feet

Example 1:

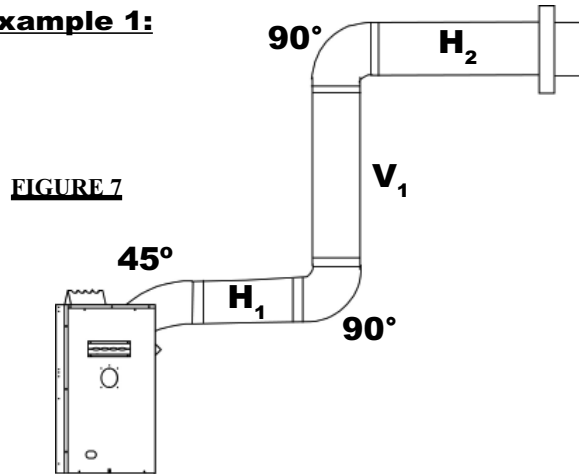
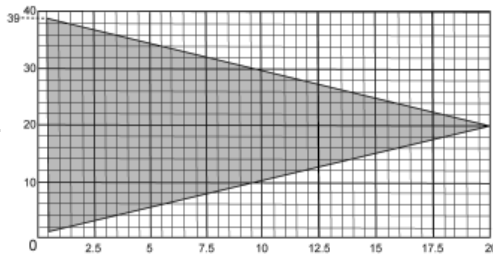

FIGURE 7

REQUIRED VERTICAL RISE IN FEET (V_T)



CALCULATED HORIZONTAL VENT RUN PLUS OFFSETS IN FEET (H_T)

The shaded area within the lines represents acceptable values for H_T and V_T.

$$\begin{aligned}
 V_1 &= 8 \text{ ft} \\
 V_T &= V_1 = 8 \text{ ft} \\
 H_1 &= 2.5 \text{ ft} \\
 H_2 &= 2 \text{ ft} \\
 H_R &= H_1 + H_2 = 2.5 + 2 = 4.5 \text{ ft} \\
 H_O &= .03(\text{one } 45^\circ \text{ elbow} + \text{two } 90^\circ \text{ elbows} - 135^\circ) \\
 &= 0.3(225 - 135^\circ) = 2.7 \text{ ft} \\
 H_T &= H_R + H_O = 4.5 + 2.7 = 7.2 \text{ ft}
 \end{aligned}$$

$$H_T + V_T = 7.2 + 8 = 15.2 \text{ ft}$$

Formula 1: **H_T ≤ V_T**
 $7.2 \leq 8$

Formula 2: **H_T + V_T ≤ 40 feet**
 $15.2 \leq 40$

Since both formulas are met, this vent configuration is acceptable.

HORIZONTAL TERMINATION

when $(H_T) > (V_T)$

Simple venting configuration (only one 45° and 90° elbow)

See graph to determine the required vertical rise V_T for the required horizontal run H_T .

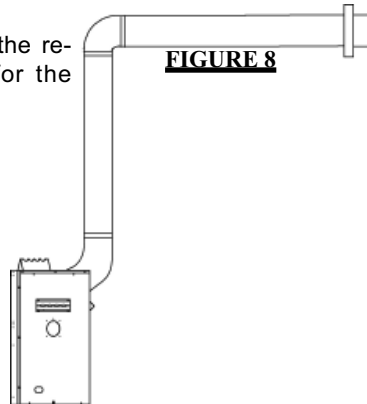

Example 2:

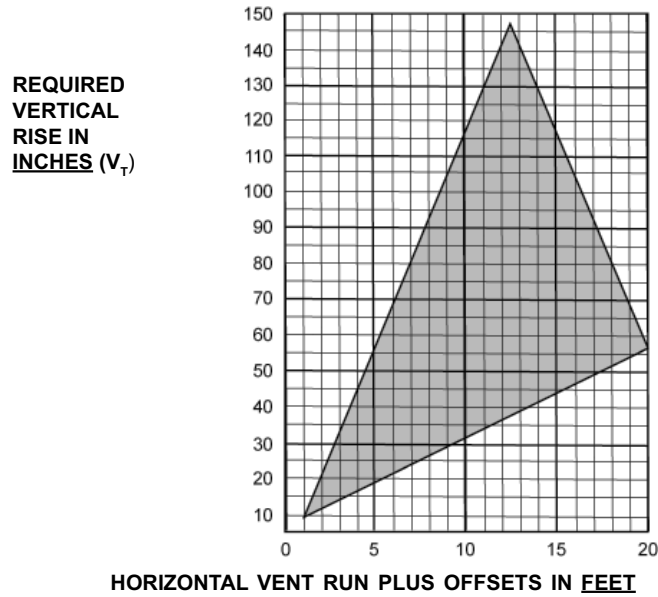
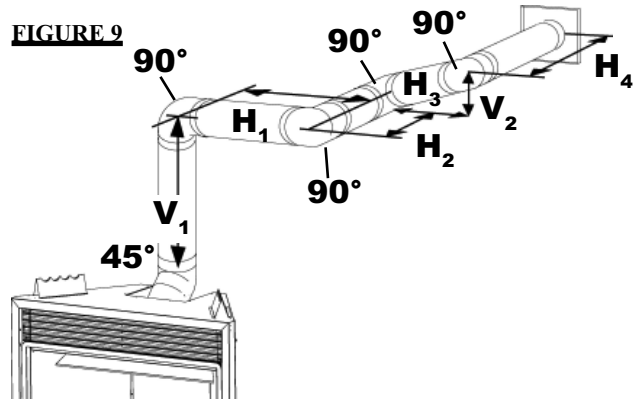

- $V_1 = 4 \text{ ft}$
- $V_2 = 1.5 \text{ ft}$
- $V_T = V_1 + V_2 = 4 \text{ ft} + 1.5 \text{ ft} = 5.5 \text{ ft}$
- $H_1 = 2 \text{ ft}$
- $H_2 = 1 \text{ ft}$
- $H_3 = 1 \text{ ft}$
- $H_4 = 1.5 \text{ ft}$
- $H_R = H_1 + H_2 + H_3 + H_4 = 2 + 1 + 1 + 1.5 = 5.5 \text{ ft}$
- $H_O = .03(\text{one } 45^\circ \text{ elbow} + \text{four } 90^\circ \text{ elbows} - 135^\circ)$
 $= .03(405 - 135) = 8.1 \text{ ft}$
- $H_T = H_R + H_O = 5.5 + 8.1 = 13.6 \text{ ft}$
- $H_T + V_T = 13.6 + 5.5 = 19.1 \text{ ft}$

Formula 1: $H_T \leq 4.2 V_T$
 $4.2 V_T = 4.2 \times 5.5 = 23.1 \text{ ft}$
 $13.6 \leq 23.1$

Formula 2: $H_T + V_T \leq 24.75 \text{ feet}$
 $19.1 \leq 24.75$

The shaded area within the lines represents acceptable values for H_T and V_T .

For vent configurations requiring more than one 45° and 90° elbow the following formulas apply:

Formula 1: $H_T \leq 4.2 V_T$

Formula 2: $H_T + V_T \leq 24.75 \text{ feet}$

Since both formulas are met, this vent configuration is acceptable.

VERTICAL TERMINATION

when $(H_T) \leq (V_T)$

Simple venting configurations

FIGURE 10

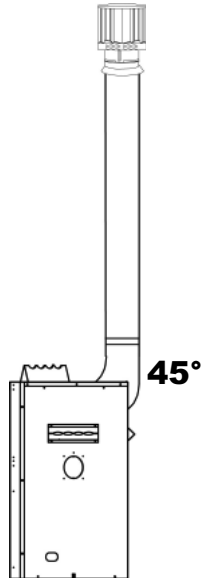

See graph to determine the required vertical rise V_T for the required horizontal run H_T .

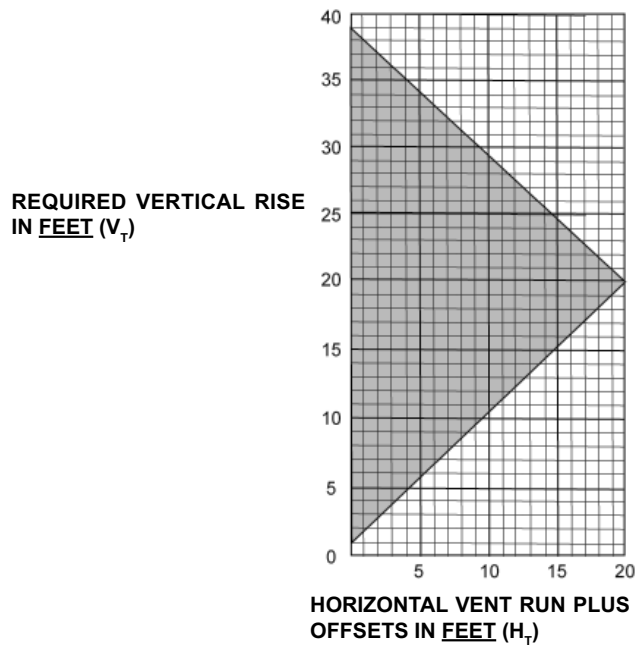

The shaded area within the lines represents acceptable values for H_T and V_T .

For vent configurations requiring more than one 45° and one 90° elbow, the following formulas apply:

Formula 1: $H_T \leq V_T$

Formula 2: $H_T + V_T \leq 40$ feet

Example 3:

FIGURE 11

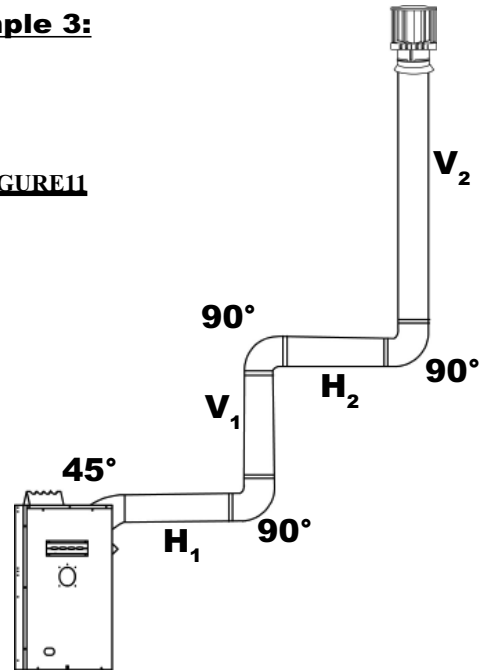

- V_1 = 5 ft
- V_2 = 10 ft
- V_T = $V_1 + V_2 = 5 + 10 = 15$ ft
- H_1 = 3 ft
- H_2 = 2.5 ft
- H_R = $H_1 + H_2 = 3 + 2.5 = 5.5$ ft
- H_o = $.03(\text{one } 45^\circ \text{ elbow} + \text{three } 90^\circ \text{ elbows} - 135^\circ)$
 $= .03(45+90+90+90-135)=5.4$
- H_T = $H_R + H_o = 5.5 + 5.4 = 10.9$ ft
- $H_T + V_T = 10.9 + 15 = 25.9$ ft

Formula 1: $H_T \leq V_T$
 $10.9 \leq 15$

Formula 2: $H_T + V_T \leq 40$ feet
 $25.9 \leq 40$

Since both formulas are met, this vent configuration is acceptable.

VERTICAL TERMINATION

when $(H_T) > (V_T)$
Simple venting configurations

FIGURE 12

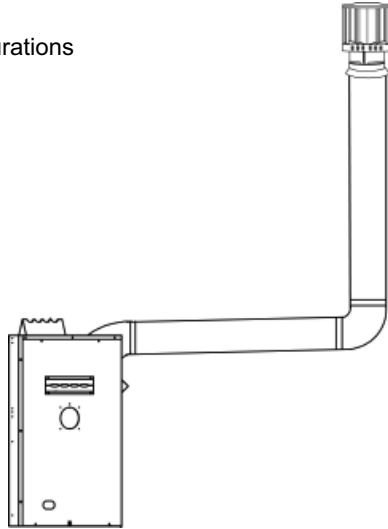

See graph to determine the required vertical rise V_T for the required horizontal run H_T .

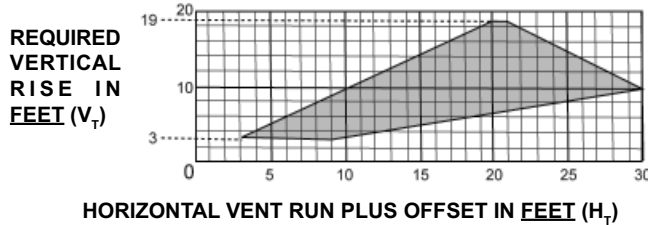

The shaded area within the lines represents acceptable values for H_T and V_T .

For vent configurations requiring more than one 45° and one 90° elbow, the following formulas apply:

Formula 1: $H_T \leq 3V_T$

Formula 2: $H_T + V_T \leq 40$ feet

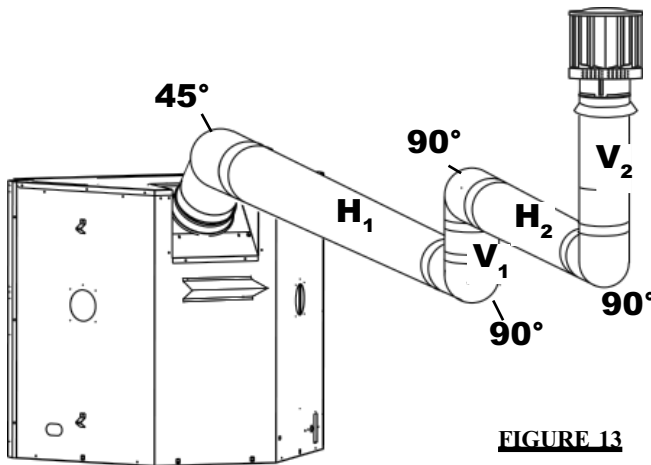

FIGURE 13

Example 4:

$$\begin{aligned}
 V_1 &= 1 \text{ ft} \\
 V_2 &= 1.5 \text{ ft} \\
 V_T &= V_1 + V_2 = 1 + 1.5 = 2.5 \text{ ft} \\
 H_1 &= 6 \text{ ft} \\
 H_2 &= 2 \text{ ft} \\
 H_R &= H_1 + H_2 = 6 + 2 = 8 \text{ ft} \\
 H_o &= .03(\text{one } 45^\circ \text{ elbow} + \text{three } 90^\circ \text{ elbow} - 135^\circ) \\
 &= .03(45 + 90 + 90 + 90 - 135) = 5.4 \text{ ft} \\
 H_T &= H_R + H_o = 8 + 5.4 = 13.4 \text{ ft} \\
 H_T + V_T &= 13.4 + 2.5 = 15.9 \text{ ft}
 \end{aligned}$$

Formula 1: $H_T \leq 3V_T$
 $3V_T = 3 \times 2.5 = 7.5$
 $13.4 > 7.5$

Since this formula is not met, this vent configuration is **unacceptable**.

Formula 2: $H_T + V_T \leq 40$ feet
 $15.9 \leq 40$

Since only formula 2 is met, this vent configuration is unacceptable and a new fireplace location or vent configuration will need to be established to satisfy both formulas.

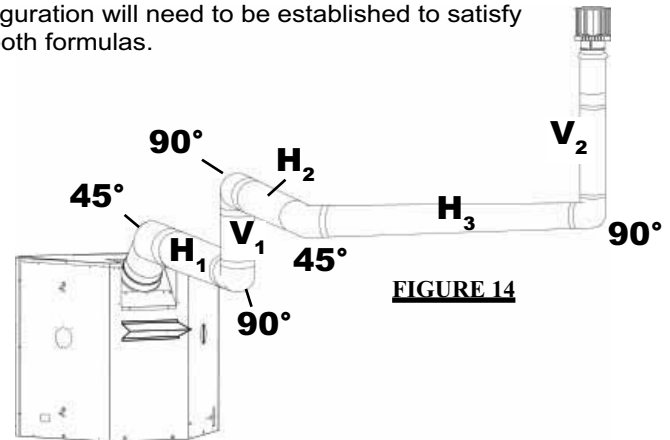

FIGURE 14

Example 5:

$$\begin{aligned}
 V_1 &= 1.5 \text{ ft} \\
 V_2 &= 8 \text{ ft} \\
 V_T &= V_1 + V_2 = 1.5 + 8 = 9.5 \text{ ft} \\
 H_1 &= 1 \text{ ft} \\
 H_2 &= 1 \text{ ft} \\
 H_3 &= 10.75 \text{ ft} \\
 H_R &= H_1 + H_2 + H_3 = 1 + 1 + 10.75 = 12.75 \text{ ft} \\
 H_o &= .03(\text{three } 90^\circ \text{ elbows} + \text{two } 45^\circ \text{ elbows} - 135^\circ) \\
 &= .03(90 + 90 + 90 + 45 + 45 - 135) = 6.75 \text{ ft} \\
 H_T &= H_R + H_o = 12.75 + 6.75 = 19.5 \text{ ft} \\
 H_T + V_T &= 19.5 + 9.5 = 29 \text{ ft}
 \end{aligned}$$

Formula 1: $H_T \leq 3V_T$
 $3V_T = 3 \times 9.5 = 28.5$
 $19.5 \leq 28.5$

Formula 2: $H_T + V_T \leq 40$ feet
 $29 \leq 40$

Since both formulas are met, this vent configuration is acceptable.

INSTALLATION

WALL AND CEILING PROTECTION

HORIZONTAL VENT SECTIONS: A minimum clearance of 2" all around the vent pipe on all horizontal runs to combustibles is required. Use firestop spacer W010-1778 (supplied).

VERTICAL VENT SECTIONS: A minimum of 1" all around the vent pipe on all vertical runs to combustibles is required. Use firestop spacer W500-0367 (not supplied).

HORIZONTAL INSTALLATION

This application occurs when venting through an exterior wall. Having determined the air terminal location, cut and frame a hole in an exterior wall with a minimum opening as required. **See Note above.**

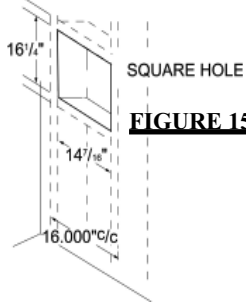

FIGURE 15

ADJUSTABLE FIRESTOP INSTALLATION

Apply a bead of caulking all around and place the firestop top, so that the vent shield covers the top of the vent within the opening.

NOTE: The firestop assembly must be installed with the vent shield to the top.

The length of the vent shield may be cut shorter for combustible walls that are less than 8 1/2" thick but the vent shield must extend the full depth of the combustible wall.

Place the firestop bottom against the firestop top and secure the two together. Adjust the assembly to ensure it is tight to the vent. Secure firestop to wall. This restricts cold air from being drawn into the room or around the fireplace. Ensure that both spacer and shield maintain the required clearance to combustibles. Once the vent pipe is installed in its final position, apply sealant W573-0002 (not supplied) between the vent pipe and the firestop spacer. **See figures 16a-c.**

This application occurs when venting through a roof. Installation kits for various roof pitches are available from your Napoleon® dealer. See Accessories to order the specific kit required.

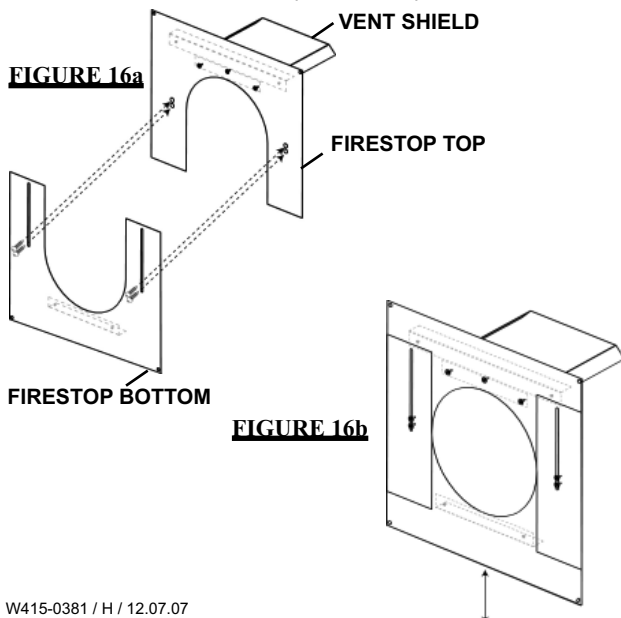
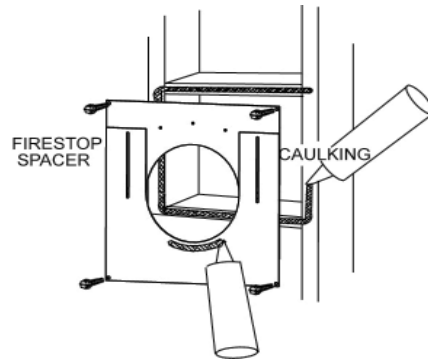

FIGURE 16a

FIGURE 16b

FIGURE 16c



VERTICAL INSTALLATION

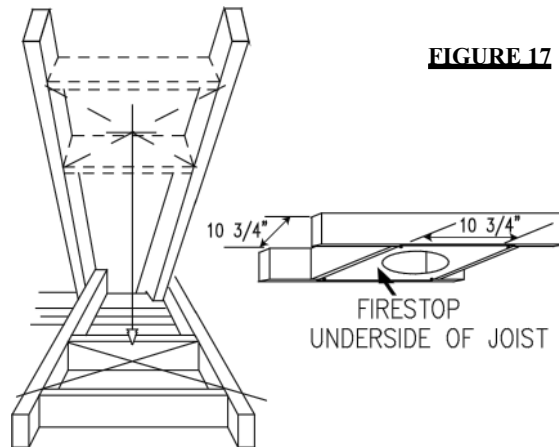

FIGURE 17

1. Determine the air terminal location, cut and frame 10 3/4" square openings in the ceiling and the roof to provide the minimum 1" clearance between the vent pipe and any combustible material. Try to center the vent pipe location midway between two joist to prevent having to cut them. Use a plumb bob to line up the center of the openings. **DO NOT FILL THIS SPACE WITH ANY TYPE OF MATERIAL.** A vent pipe shield will prevent any materials, such as insulation, from filling up the 1" air space around the pipe. Nail headers between the joist for extra support.

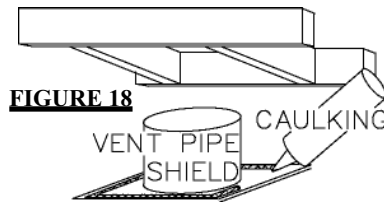

FIGURE 18

2. Apply a bead of caulking (not supplied) to the framework or to the Wolf Steel vent pipe shield plate or equivalent (in the case of a finished ceiling), and secure over the opening in the ceiling. **FIGURE 18.** A firestop must be placed on the bottom of each framed opening in a roof or ceiling that the venting system passes through. Apply a bead of caulking all around and place a firestop spacer over the vent shield to restrict cold air from being drawn into the room or around the fireplace. Ensure that both spacer and shield maintain the required clearance to combustibles. Once the vent pipe / liner is installed in its final position, apply sealant W573-0002 (not supplied) between the vent pipe and the firestop spacer.

3. In the attic, slide the vent pipe collar down to cover up the open end of the shield and tighten. This will prevent any materials, such as insulation, from filling up the 1" air space around the pipe.

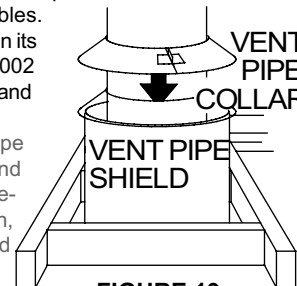

FIGURE 19

USING FLEXIBLE VENT COMPONENTS

! WARNING
 Do not allow the inside vent pipe to bunch up on horizontal or vertical runs and elbows. Keep it pulled tight. A 1 1/4" air gap between the liner and outer liner all around is required for safe operation. A spacer is required at the start, middle and end of each elbow to ensure this gap is maintained. See Figure 20.
 Spacers are attached to the inner flex liner at predetermined intervals to maintain a 1 1/4" air gap to the outer flex pipe. These spacers must not be removed.

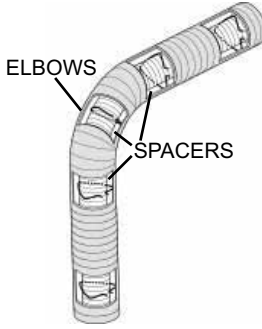

FIGURE 20

Use only approved flexible vent pipe kits marked:



"Wolf Steel Approved Venting" as identified by the stamp only on the 7" outer vent pipe.

NOTE: Eight (8") inches is the minimum bend radius allowed for the 8" diameter flexible vent pipe.

HORIZONTAL AIR TERMINAL INSTALLATION

1. Stretch the 5" diameter flexible vent pipe to the required length taking into account the additional length needed for the finished wall surface. Slip the liner a minimum of 2" over the inner sleeve of the air terminal and secure with 3 #8 screws. Apply a heavy bead of the high temperature sealant (W573-0007 not supplied).

2. Using the 8" diameter flexible vent pipe, slide over the outer combustion air sleeve of the air terminal and secure with 3 #8 screws. Seal as before.

FIGURE 21

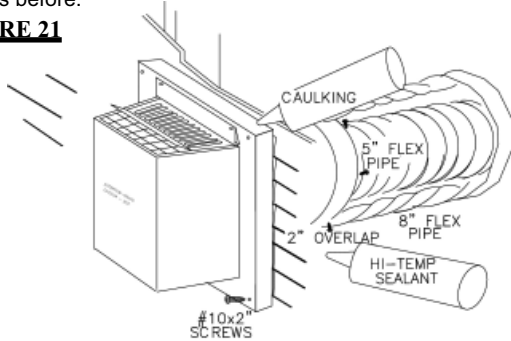

The air terminal mounting plate may be recessed into the exterior wall or siding by 1 1/2", the depth of the return flange.

For safe and proper operation of the fireplace, follow the venting instructions exactly.

All inner exhaust and outer intake vent pipe joints may be sealed using either Red RTV high temp silicone sealant or Black high temp Mill Pac with the exception of the fireplace exhaust liner which must be sealed using Mill Pac (not supplied).

3. Insert the vent pipe assemblies through the firestop maintaining the required clearance to combustibles. Holding the air terminal (lettering in an upright, readable position), secure to the exterior wall and make weather tight by sealing with caulking (not supplied).

4. Apply a heavy bead of the high temperature sealant W573-0007 (not supplied), Mill Pac, to the inside of the 5" vent pipe approximately 1" from the end. Slip the vent pipe a minimum of 2" over the fireplace vent collar and secure with 3 #8 screws.

5. Using the 8" diameter flexible vent pipe, apply sealant W573-0002 (not supplied), slide a minimum of 2" over the fireplace combustion air collar and secure with 3 #8 screws.

6. If more liner needs to be used to reach the fireplace, couple them together as illustrated. The vent system must be supported approximately every 3 feet for both vertical and horizontal runs. Use noncombustible strapping to maintain the minimum 1" clearance to combustibles.

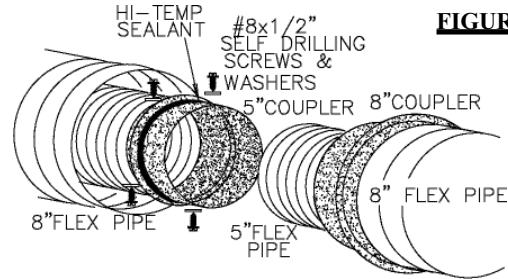

FIGURE 22

7. The vent heat shield must be installed only when terminating horizontally. Remove the two screws nearest the vent collars on the top of the fireplace. Align the vent heat shield (supplied) and secure. Adjust the vent heat shield to touch the firestop spacer.

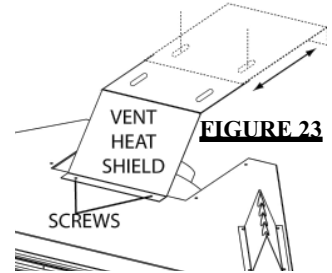
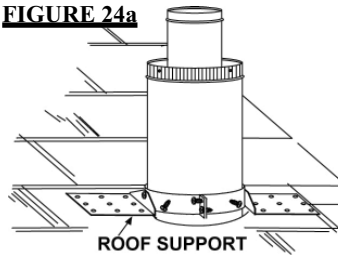

FIGURE 23

VERTICAL AIR TERMINAL INSTALLATION

FIGURE 24a



1. Fasten the roof support to the roof using the screws provided. The roof support is optional. In this case the venting is to be adequately supported using either an alternate method suitable to the authority having jurisdiction or the optional roof support.

2. Stretch the inner vent pipe to the required length. Slip

the vent pipe a minimum of 2" over the inner sleeve of the air terminal connector and secure with 3 #8 screws. Seal using a heavy bead of the high temperature sealant W573-0007 (not supplied).

3. Repeat using the outer flex vent pipe.

4. Thread the air terminal connector / liner assembly down through the roof. The air terminal must be located vertically and plumb. Attach the air terminal connector to the roof support, ensuring that the top of the air terminal is 16" above the highest point that it penetrates the roof.

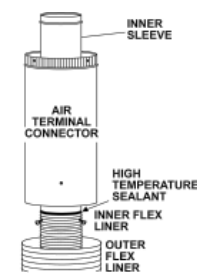

DO NOT CLAMP THE FLEXIBLE LINER

FIGURE 24b

5. Remove nails from the shingles, above and to the sides of the chimney. Place the flashing over the air terminal connector leaving a min. 3/4" of the air terminal connector showing above the top of the flashing. Slide the flashing underneath the sides and upper edge of the shingles. Ensure that the air terminal connector is properly centred within the flashing, giving a 3/4" margin all around. Fasten to the roof. Do not nail through the lower portion of the flashing. Make weather-tight by sealing with caulking. Where possible, cover the sides and top edges of the flashing with roofing material.

FIGURE 25

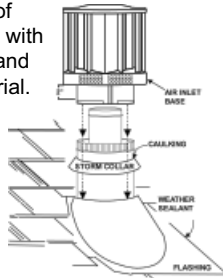

6. Aligning the seams of the terminal and air terminal connector, place the terminal over the air terminal connector making sure the liner goes into the hole in the terminal. Secure with the three screws provided.

7. Apply a heavy bead of weatherproof caulking 2" above the flashing. Note: Maintain a minimum 2" space between the air inlet base and the storm collar. Install the storm collar around the air terminal and slide down to the caulking. Tighten to ensure that a weather-tight seal between the air terminal and the collar is achieved.

8. If more liner needs to be used to reach the fireplace, couple them together as illustrated in Figure 22. The vent system must be supported approximately every 3 feet for both vertical and horizontal runs. Use noncombustible strapping to maintain a clearance to combustibles of 1".

FIREPLACE VENT CONNECTION

1. Install the 5" diameter flexible vent pipe liner to the fireplace. Secure with 3 screws and flat washers. Seal the joint and screw holes using the high temperature sealant W573-0007 (not supplied) Mill Pac.

2. Install the 8" diameter flexible vent pipe to the fireplace. Attach and seal the joints with high temperature sealant W573-0002 (not supplied).

FIGURE 26

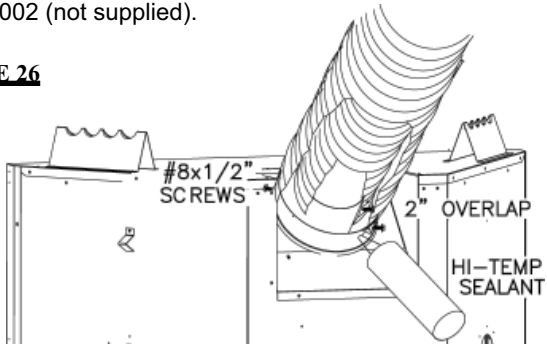

USING RIGID VENT COMPONENTS

The vent system must be supported approximately every 3 feet for both vertical and horizontal runs. Use Wolf Steel vent spacers every 3 feet and either side of each elbow to maintain the minimum 1/4" clearance between the outer and inner vent pipes. Use Wolf Steel support ring assembly or equivalent noncombustible strapping to maintain the minimum clearance to combustibles for both vertical and horizontal runs.

All inner exhaust and outer intake vent pipe joints may be sealed using either Red RTV high temp silicone sealant or Black high temp Mill Pac with the exception of the fireplace exhaust flue collar which must be sealed using Mill Pac (not supplied).

HORIZONTAL AIR TERMINAL INSTALLATION

1. Move the fireplace into position. Measure the vent length required between terminal and fireplace taking into account the additional length needed for the finished wall surface and any 1/4" overlaps between venting components.

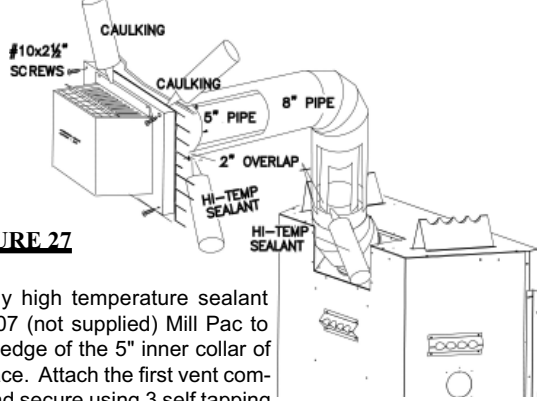

FIGURE 27

2. Apply high temperature sealant W573-0007 (not supplied) Mill Pac to the outer edge of the 5" inner collar of the fireplace. Attach the first vent component and secure using 3 self tapping screws. Repeat using 8" piping.

3. The vent heat shield must be installed only when terminating horizontally. Remove the two screws nearest the vent collars on the top of the fireplace. Align the vent shield (supplied) and secure. Adjust the heat shield to touch the firestop spacer.

4. Holding the air terminal (with the air deflectors to the top), insert into both vent pipes with a twisting motion to ensure that both the terminal sleeves engage into the vent pipes and sealant. Secure the terminal to the exterior wall and make weather tight by sealing with caulking (not supplied).

FIGURE 28

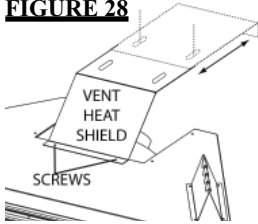

The air terminal mounting plate may be recessed into the exterior wall or siding by 1/2", the depth of the return flange.

EXTENDED HORIZONTAL AIR TERMINAL INSTALLATION

1. Follow the instructions for "Horizontal Air Terminal Installations", items 1 to 3.

2. Continue adding components alternating inner and outer venting. Ensure that all 5" venting and elbows have sufficient vent spacers attached and each component is securely fastened to the one prior. Attach the 5" telescopic sleeve to the vent run.

Repeat using a 8" telescopic sleeve. Secure and seal as before. To facilitate completion, attach 5" and 8" couplers to the air terminal.

3. Install the air terminal. See item 3 of the Horizontal Air Terminal Installation. Extend the 5" telescopic sleeve; connect to the air terminal assembly. Fasten with self tapping screws and seal. Repeat using the 8" telescopic sleeve.

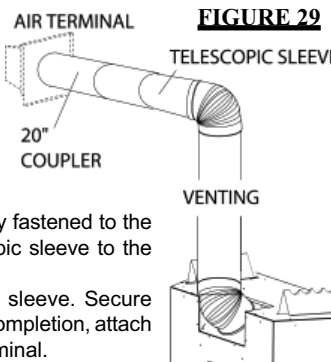
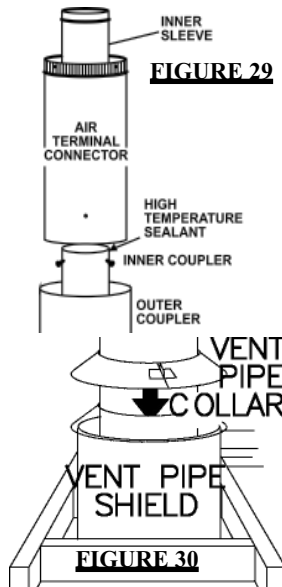

FIGURE 29

VERTICAL VENTING INSTALLATION

1. Move the fireplace into position.
2. Fasten the roof support to the roof using the screws provided. **FIGURE 21.** The roof support is optional. In this case the venting is to be adequately supported using either an alternate method suitable to the authority having jurisdiction or the optional roof support.
3. Apply high temperature sealant W573-0007 (not supplied) to the outer edge of the inner sleeve of the air terminal. Slip a 5" diameter coupler a minimum of 2" over the sleeve and secure using 3 screws.
4. Apply high temperature sealant W573-0007 (not supplied) to the outer edge of the of the outside sleeve of the air terminal. Slip a 8" diameter coupler over the sleeve and secure as before. **FIGURE 25.** Trim the 8" coupler even with the 5" coupler end.



5. Thread the air terminal pipe assembly down through the roof support and attach, ensuring that a minimum 16" of air terminal will penetrate the roof when fastened. **FIGURE 23.** If the attic space is tight, we recommend threading the Wolf Steel vent pipe collar or equivalent loosely onto the air terminal assembly as it is passed through the attic. **FIGURE 29.** The air terminal must be located vertically and plumb.

6. Remove nails from the shingles, above and to the sides of the chimney. Place the flashing over the air terminal and slide it underneath the sides and upper edge of the shingles. Ensure that the air terminal is properly centered within the flashing, giving a 3/4" margin all around. Fasten to the roof. Do NOT nail through the lower portion of the flashing. Make weather-tight by sealing with caulking. Where possible, cover the sides and top edges of the flashing with roofing material. **FIGURE 23.**

7. Aligning the seams of the terminal and air terminal connector, place the terminal over the air terminal connector making sure the inner sleeve goes into the hole in the terminal. Secure with the 3 screws provided.

8. Apply a heavy bead of weatherproof caulking 2" above the flashing. Note: Maintain a minimum of 2" space between the air inlet base and the storm collar. Install the storm collar around the air terminal and slide down to the caulking. Tighten to ensure that a weather-tight seal between the air terminal and the collar is achieved.

9. Continue adding rigid venting sections, sealing and securing as above. Attach a 5" collapsed telescopic pipe to the last section of rigid piping. Secure with screws and seal. Repeat using a 8" telescopic pipe.

10. Run a bead of high temperature sealant W573-0007 (not supplied) Mill Pac around the outside of the 5" collar on the fireplace. Pull the adjustable pipe a minimum of 2" onto the collar. Secure with 3 screws. Repeat with the 8" telescopic pipe.

11. In the attic, slide the vent pipe collar down to cover up the open end of the shield and tighten. This will prevent any materials, such as insulation, from filling up the 1" air space around the pipe.

RESTRICTING VERTICAL VENTS

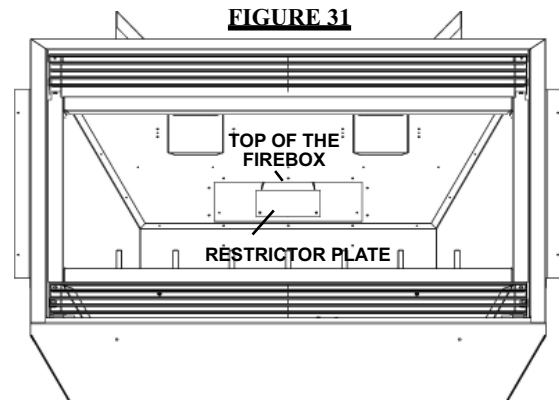

Vertical terminations may display a very active flame. As this appearance is not desirable, the vent exit must be restricted using restrictor plate, W500-0205. This reduces the velocity of the exhaust gases, slowing down the flame pattern and creating a more traditional appearance.

Remove the two screws on either side of the exhaust collar inside the firebox. Install the plate as shown. Replace the screws.

GAS INSTALLATION

Proceed once the vent installation is complete.

NOTE: All gas connections must be contained within the fireplace when complete.

1. Move the fireplace into position and secure to the floor through the 1/4" holes located at either side of the base.
2. The fireplace is designed to accept 3/8" gas supply line. The fireplace is equipped with a 3/8" manual shut-off valve.
3. Connect the gas supply in accordance to local codes. In the absence thereof, install according to the National Installation Code.
4. When flexing any gas line, support the gas valve so that the lines are not bent or kinked.
5. Check for gas leaks by brushing on a soap and water solution.

DO NOT USE OPEN FLAME.

Purge all gas lines with the glass door of the stove removed. Assure that a continuous gas flow is at the burner before re-installing the door.

OPTIONAL WALL SWITCH INSTALLATION

For ease of accessibility, an optional remote wall switch may be installed in a convenient location. A 20' length of millivolt wire is connected to the gas valve for the wall switch. However if a greater length is required route 2-strand (solid core) millivolt wire through the electrical hole located at the bottom left side of the unit. The recommended maximum lead length depends on wire size:

WIRE SIZE	MAX. LENGTH
14 gauge	100 feet
16 gauge	60 feet
18 gauge	40 feet

Attach the two leads to terminals 1 and 3 located on the gas valve.

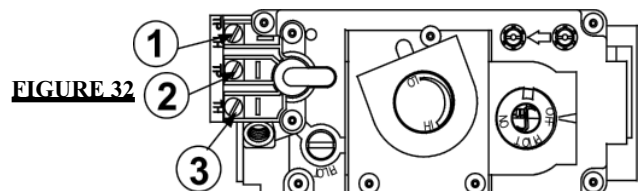

MOBILE HOME INSTALLATION

This appliance is certified to be installed as an OEM (Original Equipment Manufacturer) installation in a manufactured home or mobile home and must be installed in accordance with the manufacturer's instructions and the Manufactured Home Construction and Safety Standard, Title 24 CFR, Part 3280, in the United States or the Mobile Home Standard, CAN/CSA Z240 MH Series, in Canada. This appliance is only for use with the type(s) of gas indicated on the rating plate. A conversion kit is supplied with the mobile home appliance.

This Mobile/Manufactured Home Listed appliance comes factory equipped with a means to secure the unit. The fireplace is equipped with two 1/4" diameter holes located in the front left and right corners of the base. For mobile home installations, the fireplace must be fastened in place. Use #10 hex head screws, inserted through the holes in the base to secure. Always turn off the pilot and the fuel supply at the source, prior to moving the mobile home. After moving the mobile home and prior to lighting the fireplace, ensure that the logs are positioned correctly.

This appliance is certified to be installed in an aftermarket permanently located, manufactured (mobile) home, where not prohibited by local codes.

This fireplace is only for use with the type of gas indicated on the rating plate. This fireplace is not convertible for use with other gases, unless a certified kit is used.

Conversion Kits

The mobile home appliance is field convertible between Natural Gas (NG) and Propane (LP).

To convert from one gas to another consult your Napoleon dealer/distributor.

FRAMING

Minimum clearance to combustible construction from fireplace and vent surfaces:

Sides, back, bottom and top of the unit	0"
Recessed depth	22"
All around the vent pipe*	2"
Enclosure top	45 1/2"
Ceiling	72" from bottom of unit

***HORIZONTAL VENT SECTIONS:** A minimum clearance of 2" all around the vent pipe on all horizontal runs to combustibles is required. Use firestop spacer W010-1778 (supplied).

VERTICAL VENT SECTIONS: A minimum of 1" all around the vent pipe on all vertical runs to combustibles is required except for clearances in fireplace enclosures. Use firestop spacer W500-0367 (not supplied).

Note: In order to avoid the possibility of exposed insulation or vapour barrier coming in contact with the fireplace body, it is recommended that the walls of the fireplace enclosure be "finished" (ie: drywall/sheetrock), as you would finish any other outside wall of a home. This will ensure that clearance to combustibles is maintained within the cavity.

It is best to frame your fireplace after it is positioned and the vent system is installed. Use 2x4's and frame to local building codes. **FIGURES 33.**

It is not necessary to install a hearth extension with this fireplace system.

When roughing in the fireplace, raise the fireplace to accommodate for the thickness of the finished floor materials, i.e. tile, carpeting, hard wood, which if not planned for will interfere with the opening of the lower access door and the installation of many decorative flashing accessories.

Objects placed in front of the fireplace should be kept a minimum of 48" away from the front face.

Combustible materials may be installed flush with the front of the fireplace but must not cover or protrude past any of the black face-areas of the fireplace. Non-combustible material (brick, stone or ceramic tile) may protrude in these areas.

The fireplace requires a minimum enclosure height of 45 1/2". For temperature requirements, the enclosure space around and above the fireplace must be left unobstructed.

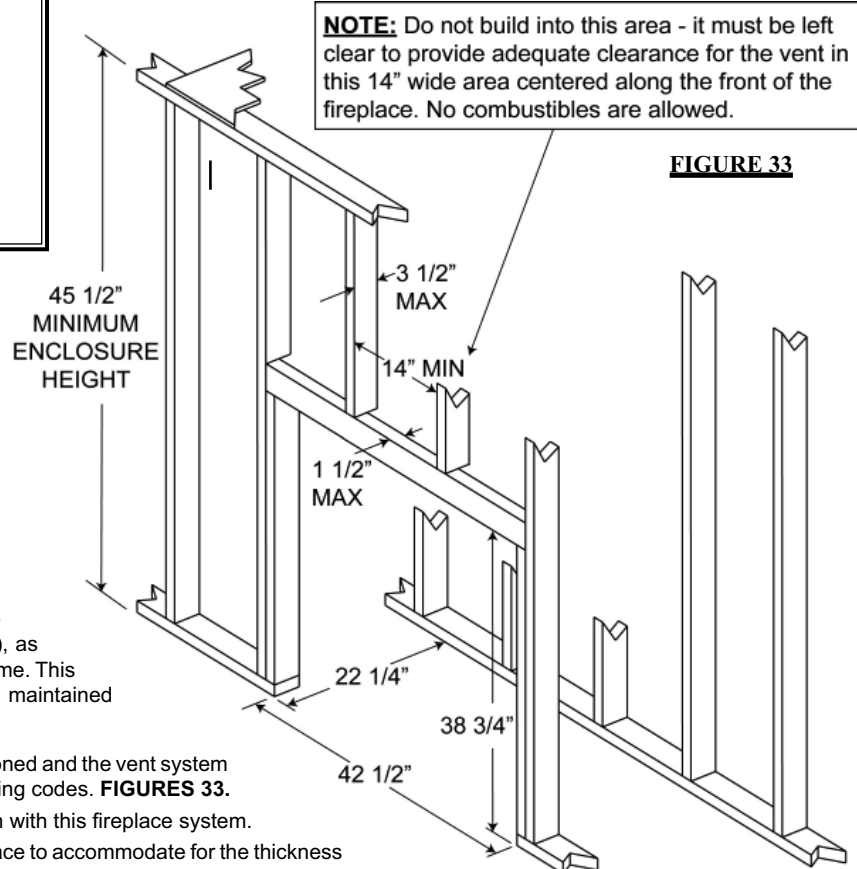

FIGURE 34

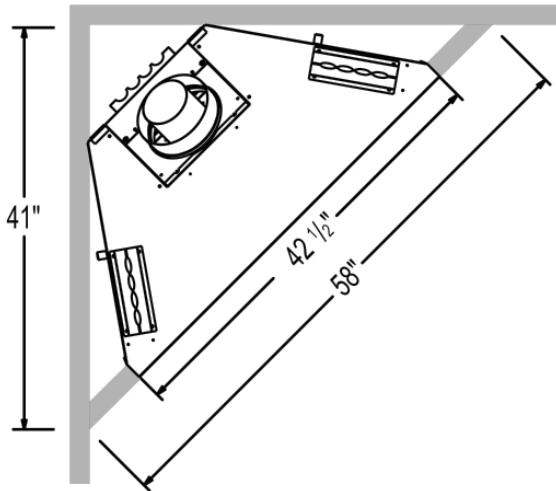
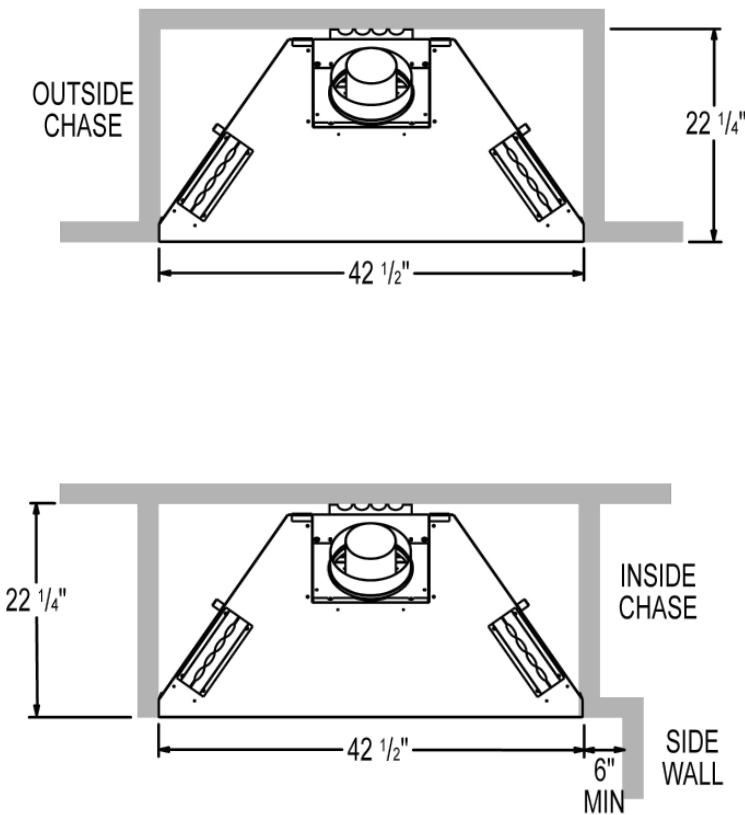

FIGURE 35a-c



NAILING TAB INSTALLATION

1) Attach the nailing tabs to the corner posts using the 2 sheet metal screws supplied. Secure through the centre of the top and bottom slots in the nailing tab and then through the existing holes in the corner posts.

If there are no existing holes, follow these instructions:

Position the nailing tab so that the front face is offset with the front edge of the corner post (approx. 1/2"). Centre the nailing tab vertically on the corner post.

Figure 36 a.

Drill through the centre of the top and bottom slots in the nailing tab. Secure using the two sheet metal screws supplied. This allows the nailing tab to slide back and forth for desired framing. **Figure 36b.**

2) To determine the final location of the nailing tab you must first determine the thickness of your finishing material (i.e. drywall). This will determine the dimension from the front edge of the corner post to the nailing tab. Once the nailing tab is in the desired location, drill through the centre hole of the nailing tab. Secure with a sheet metal screw*. **Figure 36c.**

* Additional set screws may be installed.

FIGURES 36a-c

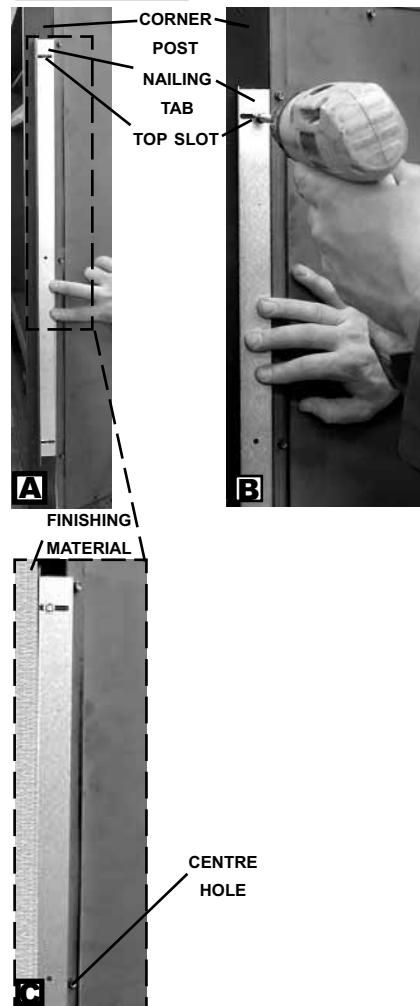

MINIMUM MANTEL AND ENCLOSURE CLEARANCES

Combustible mantel clearance can vary according to the mantel depth. **FIGURE 36.** Use the graph to help evaluate the clearance needed. Curtains, above the fireplace, must not be positioned lower than the 5" distance required for the 2" combustible mantel. These same requirements apply to any combustibles protruding on either side of the fireplace.

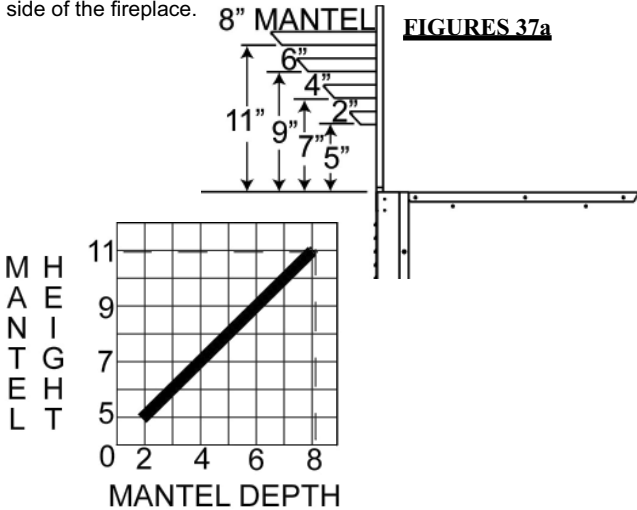

The fireplace requires a minimum enclosure height of 45 1/2". For temperature requirements, the enclosure space around and above the fireplace must be left unobstructed. **FIGURE 37.**

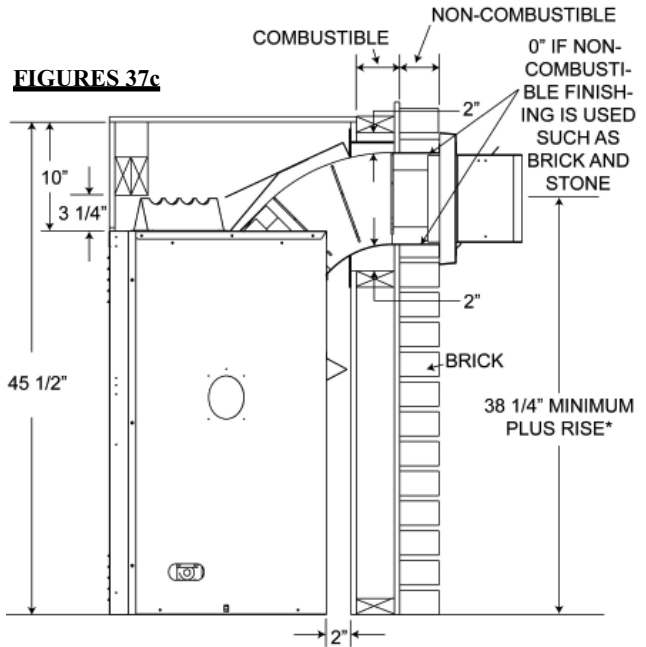

* See venting section

FINISHING

GLASS/DOOR REPLACEMENT

1. Place the door frame face down careful not to scratch the paint.

2. Center the gasketed glass inside the door frame with the thick side of the gasket facing up.

3. Bend the glass retainers located along the edge of the door frame over the gasket holding the glass in place. Careful not to break the glass.

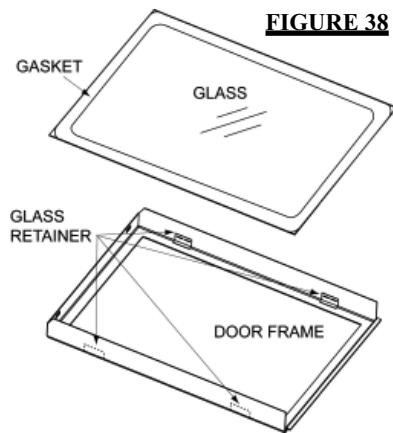

L42 LOUVRE INSTALLATION

FIGURE 39

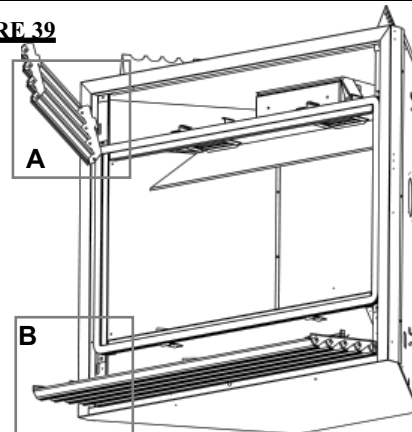

UPPER LOUVRES

Insert the louvre tabs into the slots located at the top left and right corners of the unit.

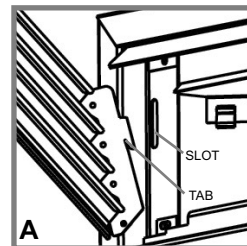

LOWER LOUVRES

Insert the hinge clips into the slots located at the bottom left and right corners of the unit.

To remove the louvres, pull the back tabs of the clips forward, while pushing the louvre assembly back. Lift the clip.

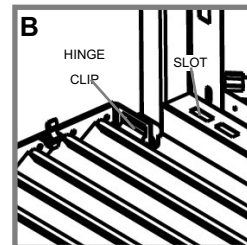

LOGO PLACEMENT

Remove the backing of the logo supplied and place on the glass viewing door, as indicated.

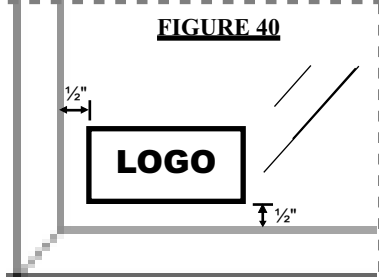

PORCELAIN REFLECTIVE PANELS

1. Remove the upper louvres, and open the glass door. Remove the logs.
2. Remove the two securing screws located on either firebox side.

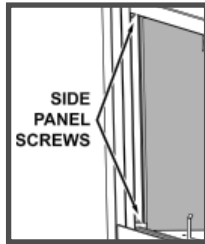

3. Place the left panel against the left side of the firebox, ensuring that it butts up to the rear panel. Secure in place using 2 of the screws previously removed. Repeat for the right side.
4. Replace the logs, glass door and louvres.

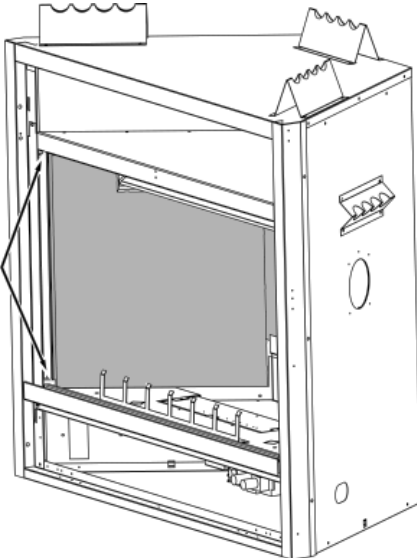

GRATE INSTALLATION

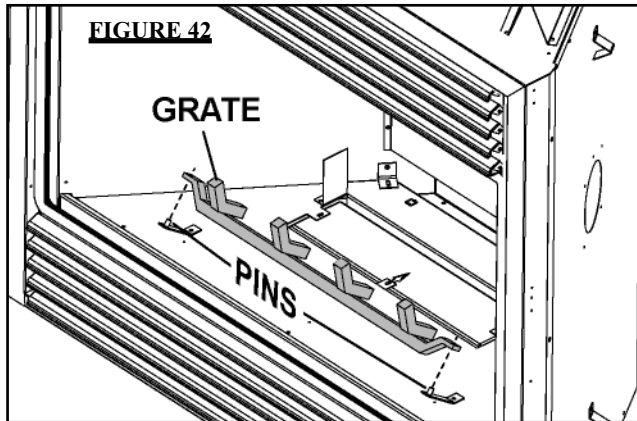

The grate for this fireplace has been removed for shipping purposes.

The grate must be installed before the logs are installed.

Remove the packaging from the grate and install onto the two pins as illustrated.

LOG PLACEMENT

PHAZER™ logs and glowing embers, exclusive to Napoleon® Fireplaces, provide a unique and realistic glowing effect that is different in every installation. Take the time to carefully position the glowing embers for a maximum glowing effect. Log colours may vary. During the initial use of the fireplace, the colours will become more uniform as colour pigments burn in during the heat activated curing process.

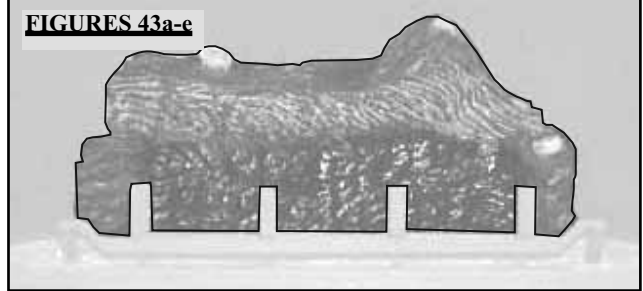

1. Place the cutout in the bottom of log (W135-0297) behind the pilot assembly. Rest the log against the back wall of the firebox.

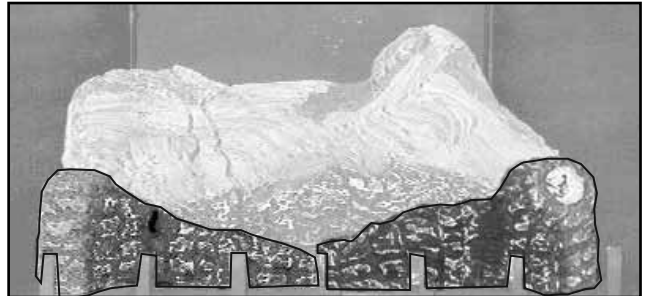

2. Move the two small logs (W135-0298 & W135-0299) into position, lining up the studs located on the burner with the holes on the bottom of the logs.

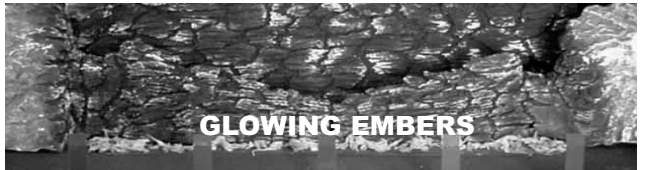

3. Tear the glowing embers into pieces and place along the front row of ports covering all of the burner area in front of the small logs. Care should be taken to shred the embers into thin, small irregular pieces as only the exposed edges of the fibre hairs will glow. The ember material will only glow when exposed to direct flame; however, care should be taken to not block the burner ports. Blocked burner ports can cause an incorrect flame pattern, carbon deposits and delayed ignition. PHAZER™ logs glow when exposed to direct flame.

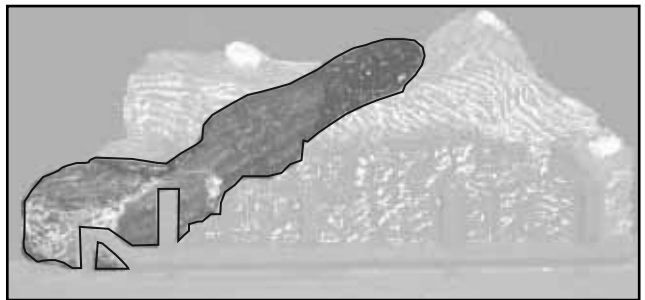

4. Place the bottom of the left crossover log (W135-0300) onto the stud on the left side of the log support. The top of the log should rest in the pocket on the back log.

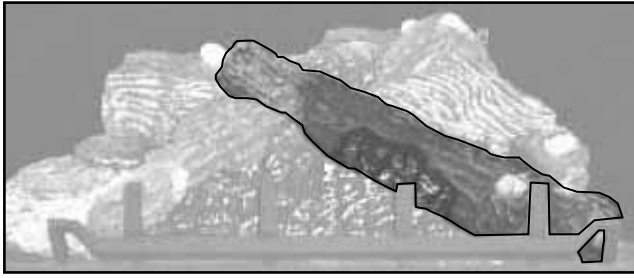

5. Place the bottom of the right crossover log (W135-0302) onto the stud on the right side of the log support. The top of the log should rest in the pocket on the left crossover log (W135-0300).

CHARCOAL EMBERS

Randomly place the charcoal embers along the front and sides of the log support tray in a realistic manner. **Fine dust found in the bottom of the bag should not be used.**

VERMICULITE

Sprinkle vermiculite around the charcoal embers.

Note: Both charcoal embers and vermiculite are not to be placed on the burner.

CHARCOAL LUMPS

Place the lumps between the logs in a realistic manner taking care not to block any of the burner ports.

OPTIONAL BLOWER INSTALLATION

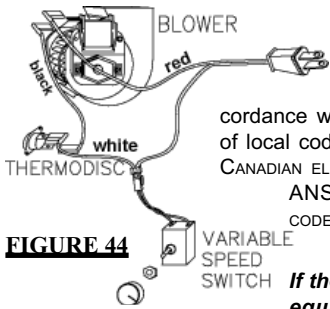

FIGURE 44

INSTALLATION TO BE DONE BY A QUALIFIED INSTALLER and must be electrically connected and grounded in accordance with local codes. In the absence of local codes, use the current CSA C22.1 CANADIAN ELECTRICAL CODE in Canada or the ANSI/NFPA 70 NATIONAL ELECTRICAL CODE in the United States

If the fireplace was not previously equipped with a blower: route a

grounded 2-wire, 60hz power cable to the receptacle / junction box. At this point, it must be strain relieved and insulated.

The three slots on the blower mounting bracket allow ease of adjustment when attaching the blower. For a quiet running blower, do not allow the assembly to sit on the firebox base.



FIGURE 45

Slide the vibration reducing pad (A) into the clip (C) and up against the threaded stud (B) at the other end. The blower must be able to be positioned entirely onto the pad.

Tilt the blower onto its side. Slide it past the controls and into the clip (C). Secure to the threaded stud using the lock washer and wing nut provided. Ensure that the blower does not touch the fireplace base or the firebox.

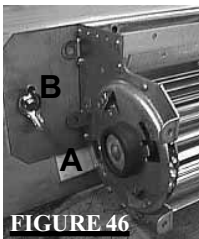

FIGURE 46



FIGURE 47

Attach the connectors from the black and white wires to the thermodisc and secure the thermodisc bracket to the securing stud at the bottom left of the unit using a lock washer and wing nut. Ensure that the thermodisc touches the firebox wall.

Attach the connectors from the black and red wires to the blower.

Attach and secure the variable speed switch using the nut provided. Plug the harness cord into the receptacle.

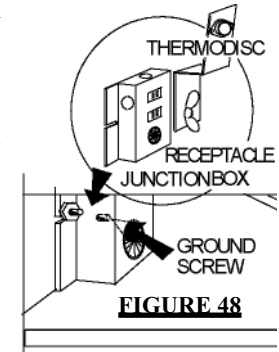

FIGURE 48

The wire harness provided in this kit is a universal harness. When installed, ensure that any excess wire is contained, preventing it from making contact with moving or hot objects.

Because the blower is thermally activated, when turned on, it will automatically start approximately 10 minutes after lighting the fireplace and will run for approximately 30-45 minutes after the fireplace has been turned off. Use of the fan increases the output of heat.

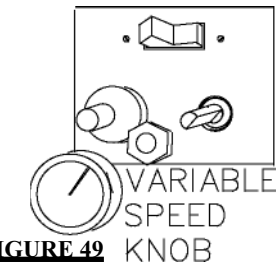

FIGURE 49

Drywall dust will penetrate into the blower bearings, causing irreparable damage. Care must be taken to prevent drywall dust from coming into contact with the blower or its compartment. Any damage resulting from this condition is not covered by the warranty policy.

OPTIONAL FAN INSTALLATION

ELECTRICAL INSTALLATION TO BE DONE BY A QUALIFIED INSTALLER and must be connected and grounded in accordance with local codes. In the absence of local codes, use the current CSA C22.1 CANADIAN ELECTRICAL CODE in Canada or the ANSI/NFPA 70 NATIONAL ELECTRICAL CODE in the United States.

To safely install the fan, turn off the electricity first.

If the fireplace was not previously equipped with a fan: route a grounded 2-wire, 60hz power cable to the junction box. At this point, it must be strain relieved and insulated.

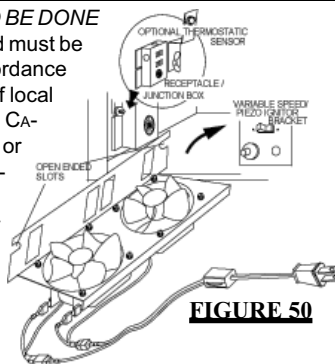

FIGURE 50

The wire harness provided in this kit is a universal harness. When installed, ensure that any excess wire is contained, preventing it from making contact with moving or hot objects.

To ease installation of the fan, remove the hinge screen and valve control door (lower louvres) from the base of the fireplace.

Position the vibration reducing pad into the clip and onto the threaded stud at the other end, piercing a hole into the pad. The fan assembly must be able to be positioned entirely onto the pad.

Slide the fan assembly past the controls and into the clip. Secure using the lock washer and nut provided.

Plug the harness cord into the receptacle.

FIGURE 51

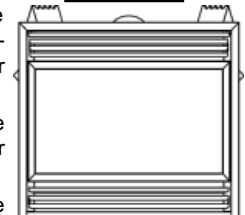

GD36 THERMOSTATIC SENSOR CONTROL

This optional kit is meant to be used only in conjunction with the GD65 Fan Kit, shown above, which may be ordered from your Wolf Steel / Napoleon® dealer.

With the thermostatic sensor option, the fan, when turned on, becomes thermally activated, and will automatically run approximately 15-30 minutes after the fireplace has been lit and for approximately 30-45 minutes after the fireplace has been turned off.

Use of the fan increases the output of heat.

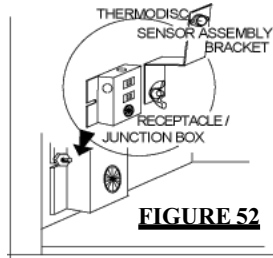

Unplug the power cord from the receptacle. Connect all wires as shown.

Attach and secure the sensor assembly bracket to the securing stud located next to the receptacle/junction box at the bottom left of the unit using the lock washer and wing nut. Ensure that the thermodisc touches the firebox wall.

Plug the power cord back into the receptacle.

When installed, ensure that any excess wire is contained, preventing it from making contact with moving or hot objects.

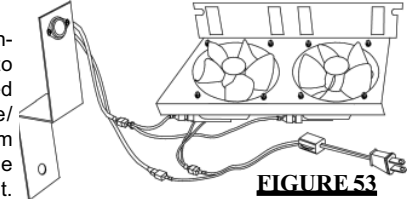

OPERATION / MAINTENANCE

OPERATING INSTRUCTIONS

When lit for the first time, the fireplace will emit a slight odour for a few hours. This is a normal temporary condition caused by the curing of the logs and the "burn-in" of internal paints and lubricants used in the manufacturing process and will not occur again.

After extended periods of non-operation such as following a vacation or a warm weather season, the fireplace may emit a slight odour for a few hours. This is caused by dust particles in the heat exchanger burning off. In both cases, open a window to sufficiently ventilate the room.

Purge the gas line with the glass door removed. Assure that a continuous gas flow is at the burner before re-installing the door.

FOR YOUR SAFETY READ BEFORE LIGHTING:

- This fireplace is equipped with a pilot which must be lit by hand while following these instructions exactly.
- Before operating smell all around the fireplace area for gas and next to the floor because some gas is heavier than air and will settle on the floor.
- Use only your hand to turn the gas control knob. Never use tools. If the knob will not turn by hand, do not try to repair it. Call a qualified service technician. Force or attempted repair may result in a fire or explosion.
- Do not use this fireplace if any part has been under water. Immediately call a qualified service technician to inspect the fireplace and replace any part of the control system and any gas control which has been under water.

WHAT TO DO IF YOU SMELL GAS

- Turn off all gas to the fireplace.
- Open windows.
- Do not try to light any appliance.
- Do not touch any electric switch; do not use any phone in your building.
- Immediately call your gas supplier from a neighbour's phone. Follow the gas supplier's instructions.
- If you cannot reach your gas supplier, call the fire department.

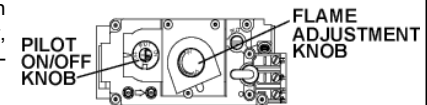

LIGHTING INSTRUCTIONS

WARNING: The gas valve has an interlock device which will not allow the pilot burner to be lit until the thermocouple has cooled. Allow approximately 60 seconds for the thermocouple to cool.

When lighting and re-lighting, the gas knob cannot be turned from pilot to off unless the knob is **depressed slightly**.

- Stop! Read the above safety information on this label.
- Turn off all electric power to the fireplace.
- Turn the gas knob clockwise  to off.
- Wait five (5) minutes to clear out any gas. If you smell gas including near the floor. Stop! Follow "B" in the above safety information on this label. If you don't smell gas go the next step.

- Turn gas knob counter-clockwise  to pilot.

- Depress slightly and hold gas knob while lighting the pilot with the push button igniter. Keep knob depressed for one minute, then release. If pilot does not continue to burn, repeat steps 3 through 5.

- With pilot lit, depress and turn gas knob counter-clockwise  to on.

- If equipped with remote on-off switch/thermostat, main burner may not come on when you turn valve to on. Remote switch must be in the on position to ignite burner.

- Turn on all electric power to the fireplace.

TO TURN OFF GAS

- Turn off all electric power to the fireplace if service is to be performed.

- Push in gas control knob slightly and turn clockwise  to off. Do not force.

MAINTENANCE

Turn off the gas and electrical power before servicing the fireplace.

CAUTION: Label all wires prior to disconnection when servicing controls. Wiring errors can cause improper and dangerous operation. Verify proper operation after servicing. This fireplace and its venting system should be inspected before use and at least annually by a qualified service person. The fireplace area must be kept clear and free of combustible materials, gasoline or other flammable vapours and liquids. The flow of combustion and ventilation air must not be obstructed.

- In order to properly clean the burner and pilot assembly, remove the logs to expose both assemblies.
- Keep the control compartment, logs, burner, air shutter opening and the area surrounding the logs clean by vacuuming or brushing, at least once a year.

- Check to see that all burner ports are burning. Clean out any of the ports which may not be burning or are not burning properly.

- Check to see that the pilot flame is large enough to engulf the thermocouple and thermopile and reaches toward the burner with the third jet.

- Replace the cleaned logs.

- Check to see that the main burner ignites completely on all openings when the gas knob for the burner is turned on. A 5 to 10 second total light-up period is satisfactory. If ignition takes longer, consult your Napoleon® dealer / distributor.

- Check that the gasketing on the sides, top and bottom of the door is not broken or missing. Replace if necessary.

ADJUSTMENTS

PILOT BURNER ADJUSTMENT

Adjust the pilot screw to provide properly sized flame. Turn in a clockwise direction to reduce the gas flow.

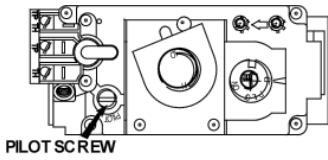

FIGURE 54

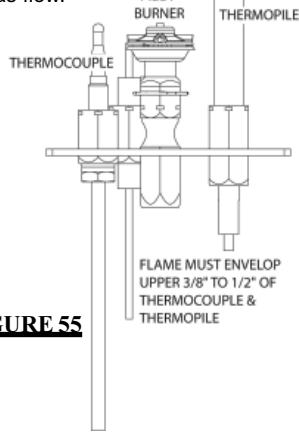

FIGURE 55

FLAME CHARACTERISTICS

It is important to periodically perform a visual check of the pilot and the burner flames. Compare them to the figures shown. If any flames appear abnormal call a qualified service technician.

FIGURE 56



VENTURI ADJUSTMENT

Air shutters have been factory set open according to the chart below:

	AIR SHUTTER
NG	1/4"
LP	7/16"

These settings are for the maximum horizontal vent run.- Adjustment may be required depending on fuel type, vent configuration and altitude.

Closing the air shutter will cause a more yellow flame, but can lead to carboning. Opening the air shutter will cause a more blue flame, but can cause flame lifting from the burner ports. The flame may not appear yellow immediately; allow 15 to 30 minutes for the final flame colour to be established.

FIGURE 57

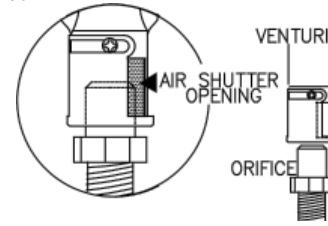

Air shutter adjustment must only be done by a qualified installer!

FIGURE 58



VENTURI COVER

To access the air shutter, remove the two screws that secure the cover to the air housing, taking care not to damage the gasket.

NOTE: Ensure burner is seated onto orifice.

REPLACEMENTS

Contact your dealer for questions concerning prices and availability of replacement parts. Normally all parts can be ordered through your Napoleon dealer or distributor.

FOR WARRANTY REPLACEMENT PARTS, A PHOTOCOPY OF THE ORIGINAL INVOICE WILL BE REQUIRED TO HONOUR THE CLAIM.

* IDENTIFIES ITEMS WHICH ARE NOT ILLUSTRATED. FOR FURTHER INFORMATION, CONTACT YOUR NAPOLEON DEALER.

When ordering replacement parts always give the following information:

1. MODEL & SERIAL NUMBER OF FIREPLACE
2. INSTALLATION DATE OF FIREPLACE
3. PART NUMBER
4. DESCRIPTION OF PART
5. FINISH

REPLACEMENT PARTS

#	PART NO.	DESCRIPTION
1	W357-0001	PIEZO IGNITER
2	W680-0004	THERMOPILE
3	W680-0005	THERMOCOUPLE**
4	W010-0800	NATURAL GAS PILOT ASSEMBLY
4	W010-0801	PROPANE GAS PILOT ASSEMBLY
5	W455-0069	NATURAL GAS PILOT INJECTOR
5	W455-0067	PROPANE GAS PILOT INJECTOR
6	W725-0025	NATURAL GAS VALVE
6	W725-0026	PROPANE VALVE
7*	W385-0245	NAPOLEON® LOGO
8*	W750-0112	20FT OF WIRE
9	W010-0864	PAN BURNER
10	GL-658	LOG SET
11*	W361-0016	GLOWING EMBERS
12*	W550-0001	CHARCOAL EMBERS
13*	W550-0002	CHARCOAL LUMPS
14	W135-0297	REAR LOG (#1)
15	W135-0300	LEFT CROSSOVER LOG (#4)
16	W135-0302	RIGHT CROSSOVER LOG (#6)
17	W135-0298	SMALL LEFT LOG (#2)
18	W135-0299	SMALL RIGHT LOG (#3)
19	W010-1819	BLACK DOOR c/w GLASS
20	W455-0026	#38 NATURAL GAS ORIFICE
20	W455-0003	#54 PROPANE GAS ORIFICE
21*	W361-0014	VERMICULITE
22	W010-1778	ADJUSTABLE FIRESTOP
23*	W500-0205	RESTRICTOR PLATE
24	W585-0138	VENT HEAT SHIELD, TOP PIECE
25	W655-0222	VENT HEAT SHIELD, BOTTOM PIECE
26	W185-0020	GRATE

**WARNING: THIS IS A FAST ACTING THERMOCOUPLE. IT IS AN INTEGRAL SAFETY COMPONENT. REPLACE ONLY WITH A FAST ACTING THERMOCOUPLE SUPPLIED BY WOLF STEEL LTD.

FLEXIBLE VENT KITS

* GD420 (5 FT)		
PART NO.	DESCRIPTION	
27	W010-0772	5" FLEXIBLE VENT PIPE - (5 FT) c/w SPACERS
27	W730-0012	8" FLEXIBLE VENT PIPE - (5 FT)
* GD430 (10 FT)		
PART NO.	DESCRIPTION	
28	W730-0013	8" FLEXIBLE VENT PIPE - (10 FT)
28	W010-0773	5" FLEXIBLE VENT PIPE - (10 FT) c/w SPACERS
29	W010-0810	WALL SUPPORT ASSEMBLY

TERMINAL KITS

30	PERISCOPE	- GD401
31	WALL TERMINAL KIT	- GD422

ROOF TERMINAL KITS

32	1/12 TO 7/12 PITCH	-GD410
32	8/12 TO 12/12 PITCH	-GD411
32	FLAT ROOF	-GD412

PART NO. DESCRIPTION

33	W010-0774	AIR TERMINAL
34	W120-0015	VERTICAL CAP
35	W170-0086	STORM COLLAR
36	W010-0453	ROOF SUPPORT
37	W263-0065 /	ROOF FLASHING
	W263-0066 /	
	W263-0067	

ACCESSORIES

#	PART NO.	DESCRIPTION
38*	W573-0007	10.3OZ TUBE HIGH TEMP SEALANT
39*	W175-0166	5" COUPLER
39*	W175-0002	8" COUPLER
40	L42K	LOUVRE KIT - UPPER & LOWER - BLACK
40	L42PB	LOUVRE KIT - UPPER & LOWER - POLISHED BRASS
40	L42SS	LOUVRE KIT - UPPER & LOWER - BRUSHED STAINLESS STEEL
41	GDOI42BG	ORNAMENTAL INSET - BRUSHED GOLD
41	GDOI42K	ORNAMENTAL INSET - BLACK
41	GDOI42G	ORNAMENTAL INSET - GOLD
41	GDOI42SS	ORNAMENTAL INSET - STAINLESS STEEL
42*	W690-0001	MILLIVOLT THERMOSTAT
43*	W660-0010B	REMOTE CONTROL - ADVANTAGE
43*	W660-0011B	REMOTE CONTROL - ADVANTAGE PLUS
44*	W660-0013	MODULATING THERMOSTATIC HAND HELD REMOTE
45*	GD825N	MODULATING VALVE REGULATOR FOR W660-0013 - NG
46*	GD825P	MODULATING VALVE REGULATOR FOR W660-0013 - P
46	W500-0163	FIRESTOP SPACER (RIGID VENTING)
47	GD501	HEAT GUARD
48*	W585-0096	SOFFIT HEAT SHIELD
49*	W010-0810	WALL SUPPORT ASSEMBLY
50*	W175-0170	DURA-VENT ZERO CLEARANCE ADAPTOR
51	W170-0086	VENT PIPE COLLAR
52	W585-0092	VENT PIPE SHIELD
53	GZ550-1KT	BLOWER KIT
54*	GD65	FAN KIT
55*	GD36	THERMOSTATIC SENSOR CONTROL KIT FOR USE WITH GD65 ONLY
56*	W500-0033	VARIABLE SPEED SWITCH WALL MOUNTING PLATE
57*	KB35	VARIABLE SPEED SWITCH
58	GA-566	HOT AIR DISTRIBUTION KIT
59*	W690-0005	THERMOSTAT - 110V FOR USE WITH GA-566 ONLY
60*	GA-70	EXTENSION KIT - 5 FT
61	GA-72	HOT AIR EXHAUST KIT
62*	W175-0211	CONVERSION KIT - NG-LP
62*	W175-0212	CONVERSION KIT - LP-NG
63*	W500-0397	VERTICAL FIRESTOP

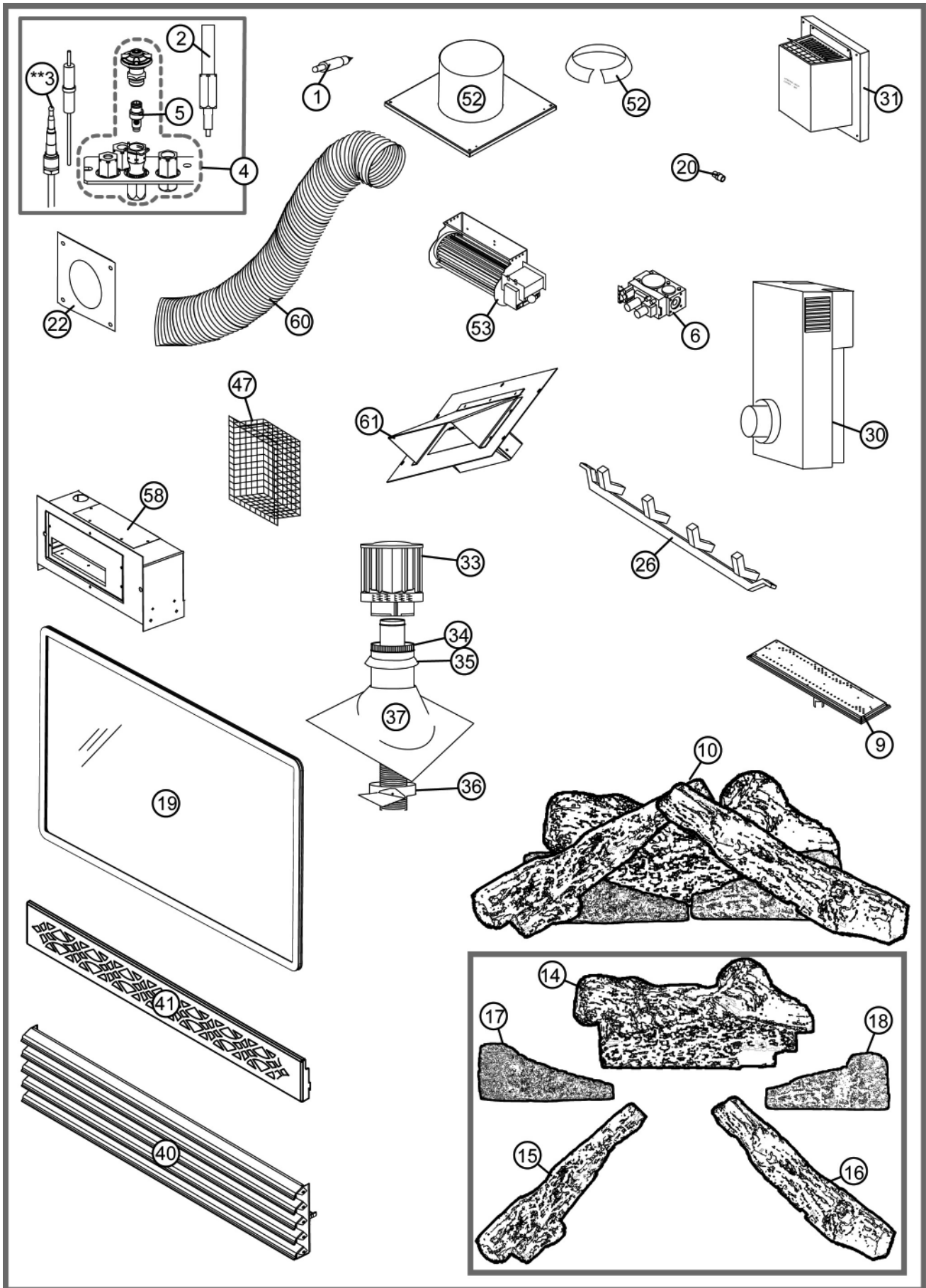

TROUBLE SHOOTING GUIDE

BEFORE ATTEMPTING TO TROUBLESHOOT, PURGE YOUR UNIT AND INITIALLY LIGHT THE PILOT AND THE MAIN BURNER WITH THE GLASS DOOR REMOVED.

SYMPTOM	PROBLEM	TEST SOLUTION
---------	---------	---------------

Main burner goes out; pilot stays on.	Pilot flame is not large enough or not engulfing the thermopile	<ul style="list-style-type: none"> - turn up pilot flame. - replace pilot assembly.
	Thermopile shorting	<ul style="list-style-type: none"> - clean thermopile connection to the valve. Reconnect. - replace thermopile / valve.
	Remote wall switch wire is too long; too much resistance in the system.	<ul style="list-style-type: none"> - shorten wire to correct length or wire gauge.
	Faulty thermostat or switch.	<ul style="list-style-type: none"> - replace.

Main burner goes out; pilot goes out.	Refer to "MAIN BURNER GOES OUT; PILOT STAYS ON"	
	Vent is blocked	<ul style="list-style-type: none"> - check for vent blockage.
	Vent is re-circulating	<ul style="list-style-type: none"> - check joint seals and installation.
	5" flexible vent has become disconnected from fireplace.	<ul style="list-style-type: none"> - re-attach to fireplace.

Pilot goes out when the gas knob is released. The gas valve has an interlock device which will not allow the pilot burner to be lit until the thermocouple has cooled. Allow approximately 60 seconds for the thermocouple to cool.	System is not correctly purged.	<ul style="list-style-type: none"> - purge the gas line with the glass door removed.
	Out of propane gas.	<ul style="list-style-type: none"> - fill the tank.
	Pilot flame is not large enough	<ul style="list-style-type: none"> - turn up the pilot flame.
	Pilot flame is not engulfing the thermocouple.	<ul style="list-style-type: none"> - gently twist the pilot head to improve the flame pattern around the thermocouple.
	Thermocouple shorting / faulty.	<ul style="list-style-type: none"> - loosen and tighten thermocouple. - clean thermocouple and valve connection. - replace thermocouple. - replace valve.
	Faulty valve.	<ul style="list-style-type: none"> - replace.

Pilot burning; no gas to main burner; gas knob is on 'HI'; wall switch / thermostat is on.	Thermostat or switch is defective.	<ul style="list-style-type: none"> - connect a jumper wire across the wall switch terminals; if main burner lights, replace switch / thermostat.
	Wall switch wiring is defective.	<ul style="list-style-type: none"> - disconnect the switch wires & connect a jumper wire across terminals 1 & 3; if the main burner lights, check the wires for defects and / or replace wires.
	Main burner orifice is plugged.	<ul style="list-style-type: none"> - remove stoppage in orifice.
	Faulty valve.	<ul style="list-style-type: none"> - replace.

Pilot will not light.	No spark at pilot burner	
		<ul style="list-style-type: none"> - check if pilot can be lit by a match - check that the wire is connected to the push button igniter. - check if the push button igniter needs tightening. - replace the wire if the wire insulation is broken or frayed. - replace the electrode if the ceramic insulator is cracked or broken. - replace the push button igniter.
	Out of propane gas	<ul style="list-style-type: none"> - fill the tank.
	Spark gap is incorrect	<ul style="list-style-type: none"> - spark gap should be 0.150" to 0.175" (5/32" to 11/64" approx.) from the electrode tip and the pilot burner. To ensure proper electrode location, tighten securing nut (finger tight plus 1/4 turn).
	No gas at the pilot burner	
		<ul style="list-style-type: none"> - check that the manual valve is turned on. - check the pilot orifice for blockage. - replace the valve. - call the gas distributor.

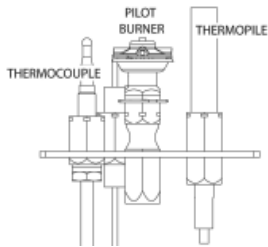

Pilot goes out while standing; Main burner is in 'OFF' position.	Gas piping is undersized.	<ul style="list-style-type: none"> - turn on all gas appliances and see if pilot flame flutters, diminishes or extinguishes, especially when main burner ignites. Monitor appliance supply working pressure. - check if supply piping size is to code. Correct all undersized piping.
--	---------------------------	---

Flames are consistently too large or too small. Carboning occurs.	Unit is over-fired or under-fired.	<ul style="list-style-type: none"> - check pressure readings: Inlet pressure can be checked by turning screw (A) counter-clockwise 2 or 3 turns and then placing pressure gauge tubing over the test point. Gauge should read 7" (minimum 4.5") water column for natural gas or 13" (11" minimum) water column for propane. Check that main burner is operating on "HI". Outlet pressure can be checked the same as above using screw (B). Gauge should read 3.5" water column for natural gas or 10" water column for propane. Check that main burner is operating on "HI". AFTER TAKING PRESSURE READINGS, BE SURE TO TURN SCREWS CLOCKWISE FIRMLY TO RESEAL. DO NOT OVERTORQUE. Leak test with a soap and water solution.
---	------------------------------------	---

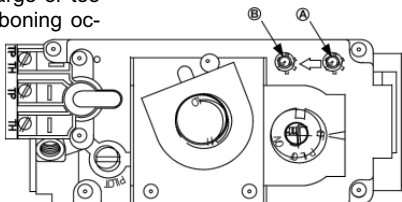

SYMPTOM	PROBLEM	TEST SOLUTION
Flames are very aggressive.	Door is ajar	- fit door assembly into the lower support brackets and secure the four door latches.
	Venting action is too great.	-restrict vent exit with restrictor plate, W500-0205.
Main burner flame is a blue, lazy, transparent flame.	Blockage in vent.	- remove blockage. In extremely cold conditions, ice buildup may occur on the terminal and should be removed as required.
	Incorrect installation.	- refer to Figure 23 to ensure correct location of storm collars.
Carbon is being deposited on glass, logs or combustion chamber surfaces.	Air shutter has become blocked	- ensure air shutter opening is free of lint or other obstructions.
	Flame is impinging on the logs or combustion chamber.	- check that the logs are correctly positioned. - open air shutter to increase the primary air. - check the input rate: check the manifold pressure and orifice size as specified by the rating plate values. - check that the door gasketing is not broken or missing and that the seal is tight. - check that both 5" and 8" vent liners are free of holes and well sealed at all joints. - check that minimum rise per foot has been adhered to for any horizontal venting.
White / grey film forms.	Sulphur from fuel is being deposited on glass, logs or combustion chamber surfaces.	- clean the glass with a recommended gas fireplace glass cleaner. DO NOT CLEAN GLASS WHEN HOT. If deposits are not cleaned off regularly, the glass may become permanently marked.
Remote wall switch is in "OFF" position; main burner comes on when gas knob is turned to "ON" position.	Wall switch is mounted upside down	- reverse.
	Remote wall switch is grounding.	- replace.
	Remote wall switch wire is grounding.	- check for ground (short); repair ground or replace wire.
	Faulty valve.	- replace.