

This wood appliance needs periodic inspection and repair. It is against United States federal regulations to operate this wood appliance in a manner inconsistent with the operating instructions in this manual.



INSTALLATION AND OPERATION MANUAL

S20-1

INSTALLER:

Leave this manual with the appliance.

CONSUMER:

Retain this manual for future reference.

SAFETY INFORMATION

! WARNING

If the information in these instructions are not followed exactly, a fire or explosion may result causing property damage, personal injury or death. Please read the entire manual before you install and use your appliance. This heater has not been tested with an unvented gas log set. To reduce risk of fire or injury, do not install an unvented gas log set into the heater.

- This heater can be very hot when burning.
- Combustible materials such as firewood, wet clothing, etc. placed too close can catch fire.
- Children and pets must be kept from touching the heater when it is hot.
- The chimney must be sound and free of cracks. Before installing this appliance, contact the local building or fire authority and follow their guidelines.
- Always operate this appliance with the door(s) or screen (where applicable) tightly closed.
- Burn wood behind the log retainer directly on the firebricks.
- Do not use an elevated grate or otherwise raise the fire.
- This appliance is designed to burn natural wood only. Higher efficiencies and lower emissions generally result when burning air dried seasoned hardwoods, as compared to softwoods or to green or freshly cut hardwoods.
- Do not start a fire with chemicals or fluids such as gasoline, engine oil, etc.
- Do not burn trash or garbage, lawn clippings/waste, rubber, waste petroleum products, paints or paint thinners/solvents, plastic, materials containing asbestos, construction debris, railroad ties or treated wood, manure or animal remains, salt water driftwood or salted materials, unseasoned wood, coal, charcoal, coloured paper, cardboard, plywood or particleboard. Burning these materials may result in release of toxic fumes or render the appliance ineffective and cause smoke.
- Do not let the appliance become hot enough for any part to glow red.

Wood Stoves ONLY

- At least 14 squares inches (90.3 square centimeters) of outside air must be admitted to the room or directly to the appliance through a 4" (101.6mm) diameter pipe.
- KEEP THE STOVE TOP TEMPERATURE BELOW 700°F (371°C). Attempts to achieve heat output rates that exceed design specifications can result in steel distortion and damage.

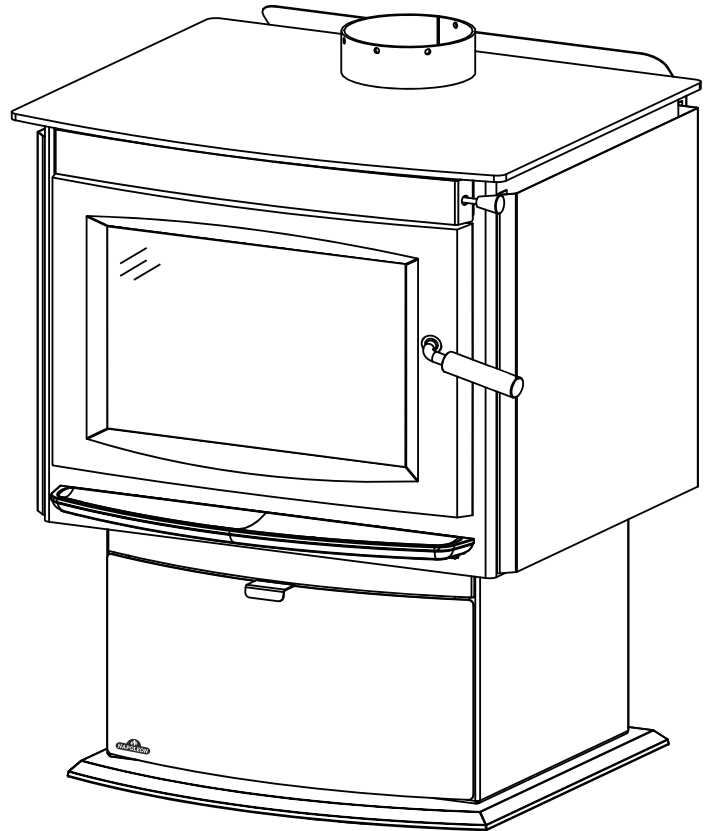

FOR INDOOR USE ONLY

U.S. ENVIRONMENTAL PROTECTION AGENCY (E.P.A.) CERTIFIED TO COMPLY WITH 2020 PARTICULATE EMISSION STANDARDS USING CORD WOOD. THIS APPLIANCE HAS BEEN TESTED BY POLYTESTS AND LISTED BY CSA GROUP TO STANDARDS: ULC S627 AND UL1482. ASTM E3053-17; ASTM E2515-11 METHODS ALT-125 AS REFERENCED INTO 40 CFR PART 60 SUBPART AAA. REFERENCE #: 161746



Wolf Steel Ltd., 24 Napoleon Rd., Barrie, ON, L4M 0G8 Canada / 103 Miller Drive, Crittenden, Kentucky, USA, 41030
 Phone 1 (866) 820-8686 • www.napoleon.com • hearth@napoleon.com

WARNING

- This appliance is hot when operated and can cause severe burns if contacted.
- Any changes or alterations to this appliance or its controls can be dangerous and is prohibited.
- Do not operate appliance before reading and understanding operating instructions. Failure to operate appliance according to operating instructions could cause fire or injury.
- Before installing this appliance, contact the local building or fire authority and follow their guidelines.
- This appliance must be installed by a qualified installer. Never try to repair or replace any part of the appliance unless instructions are given in this manual. All other work should be done by a trained technician.
- Risk of burns. The appliance should be turned off and cooled before servicing.
- Do not operate without fully assembling all components. Do not install damaged, incomplete or substitute components.
- Do not let the appliance become hot enough for any part to glow red.
- Risk of cuts and abrasions. Wear protective gloves, footwear and safety glasses during installation. Sheet metal edges may be sharp.
- All wiring should be done by a qualified electrician and shall be in compliance with local codes. In the absence of local codes, use the current CSA22.1 Canadian Electric Code in Canada or the current National Electric Code ANSI/NFPA No. 70 in the United States.
- If equipped, burning your appliance with the ash dump door ajar creates a fire hazard that may result in discoloration to the door, internal damage to the appliance or a house and/or chimney fire.
- Do not connect this appliance to a chimney flue serving another appliance.
- Clothing or other flammable material should not be placed on or near the appliance. Objects placed in front of the appliance must be kept a minimum of 48" (121.9cm) away from the front face of the appliance.
- Due to high temperatures, the appliance should be located out of traffic and away from furniture and draperies.
- Even after the appliance is off, it will remain hot for an extended period of time.
- Any safety screen or guard removed for servicing must be replaced prior to operating the appliance.
- Under no circumstances should this appliance be modified.
- This appliance must not be connected to a chimney flue pipe servicing a separate solid fuel burning appliance.
- Do not operate the appliance with the glass door removed, cracked or broken. Replacement of the glass should be done by a licensed or qualified service person.
- Do not strike or slam shut the appliance glass door.
- Only doors / optional fronts certified with the appliance are to be installed on the appliance.
- If the appliance is not properly installed, a house fire may result. Do not expose the appliance to the elements (ex. rain, etc.) and keep the appliance dry at all times. Wet insulation will produce an odour when the appliance is used.
- The chimney must be sound and free of cracks. Clean your chimney a minimum of twice a year and as required.
- Children and adults should be alerted to the hazards of high surface temperature and should stay away to avoid burns or clothing ignition.
- Young children should be carefully supervised when they are in the same room as the appliance. Toddlers, young children and others may be susceptible to accidental contact burns. A physical barrier is recommended if there are at risk individuals in the house. To restrict access to an appliance or stove, install an adjustable safety gate to keep toddlers, young children and other at risk individuals out of the room and away from hot surfaces.
- Ensure you have incorporated adequate safety measures to protect infants/toddlers from touching hot surfaces.
- Check with your local hearth specialty dealer for safety screens and hearth guards to protect children from hot surfaces. These screens and guards must be fastened to the floor.
- Keep the packaging material out of reach of children and dispose of the material in a safe manner. As with all plastic bags, these are not toys and should be kept away from children and infants.
- Do not start a fire with chemicals or fluids such as gasoline, engine oil, etc.



 **WARNING**

- Your appliance requires periodic maintenance and cleaning. Failure to maintain your appliance may lead to smoke spillage in your home.
- Ashes must be disposed in a metal container with a tight lid and placed on a non-combustible surface well away from the home or structure until completely cool.
- Ensure clearances to combustibles are maintained when building a mantel or shelves above the appliance. Elevated temperatures on the wall or in the air above the appliance can cause melting, discolouration or damage to decorations, a TV or other electronic components.

 **WARNING:** This product can expose you to chemicals including lead and lead compounds, which are known to the State of California to cause cancer, and chemicals including carbon monoxide, which are known to the State of California to cause birth defects or other reproductive harm. For more information, go to www.P65Warnings.ca.gov.

For wood appliances:

- Lower emissions generally result when burning air dried seasoned hardwoods, as compared to softwoods or too green or freshly cut hardwoods. Burning wet unseasoned wood can cause excessive creosote accumulation. When this is ignited it can cause a chimney fire that may result in a serious house fire.
- This appliance is designed to burn natural wood only. Do not burn trash or garbage, lawn clippings / waste, rubber, waste petroleum products, paints or paint thinners / solvents, plastic, materials containing asbestos, construction debris, railroad ties or treated wood, manure or animal remains, salt water driftwood or salted materials, unseasoned wood, coal, charcoal, coloured paper, gift wrapping, cardboard, plywood or particleboard. Burning these materials may result in release of toxic fumes or render the appliance ineffective and cause smoke.
- Burn wood directly on the firebricks. Do not elevate grate or otherwise raise the fire.
- Do not store wood within appliance installation clearances or within the space required for re-fueling and ash removal.
- If equipped, the catalyst must be installed and in good working order. It is recommended that the catalyst is inspected at least three times per heating season.

table of contents

1.0	general information	5	7.0	maintenance	31
1.1	dimensions	5	7.1	ash removal procedures	31
1.2	specifications	6	7.1.1	ash removal with ash disposal kit	31
1.3	general instructions	6	7.2	creosote formation and removal	32
1.4	general information	7	7.3	runaway or chimney fire	32
1.5	rating plate information	8	7.4	chimney cleaning	32
2.0	installation planning	9	7.5	door glass replacement	33
2.1	appliance placement	9	7.6	care of glass	34
2.2	pedestal back plate installation	9	7.7	door gasket replacement	34
2.3	minimum clearance to combustibles	10	7.8	wood	35
2.4	alcove installation	10	8.0	replacement parts	36
2.5	floor protection	11	8.1	overview part 1	37
2.6	outside air	11	8.2	overview part 2	38
3.0	installation	12	9.0	accessories	39
3.1	chimney	13	10.0	troubleshooting	40
3.1.1	chimney connection	14	11.0	warranty	41
3.1.2	adding sections	15			
3.1.3	typical through the ceiling	16			
3.1.4	typical through the wall	17			
3.1.5	typical existing masonry	18			
4.0	finishing	19			
4.1	door removal	19			
4.2	door adjustment	20			
4.3	door handle installation	20			
4.4	brick and baffle installation	21			
4.5	secondary air tubes	22			
4.6	ash lip removal / installation	23			
4.7	logo placement	23			
5.0	optional installation	24			
5.1	blower kit installation	24			
5.2	ash disposal kit (ADS20)	25			
6.0	operation	26			
6.1	optimum burn method	27			
6.2	optional blower operation	27			
6.3	air control	28			
6.4	fire extinguishers / smoke & carbon monoxide detectors	28			
6.5	fuel	29			
6.6	lighting a fire	29			
6.6.1	flash fire	29			
6.6.2	extended fire	30			
6.7	smoking	30			

note:

The information throughout this manual is believed to be correct at the time of printing. Wolf Steel Ltd. reserves the right to change or modify any information within this manual at any time without notice. Changes, other than editorial, are denoted by a vertical line in the margin.

1.1 dimensions

RIGHT SIDE VIEW

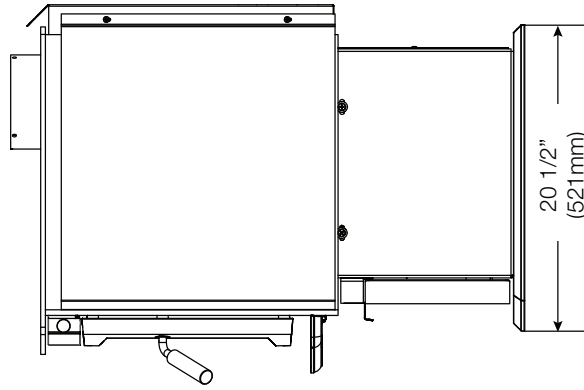

FRONT VIEW

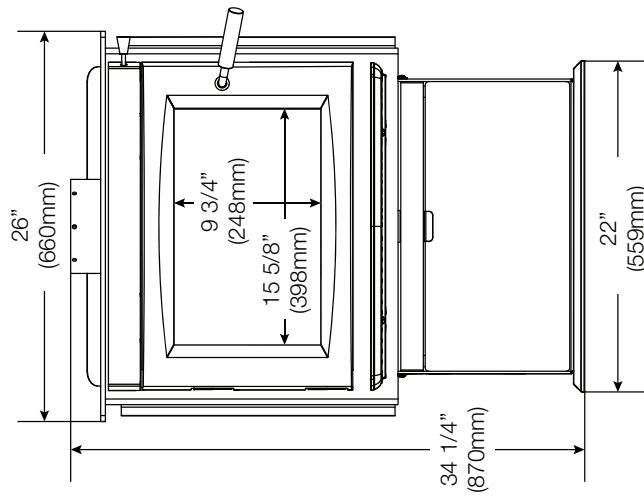

TOP VIEW

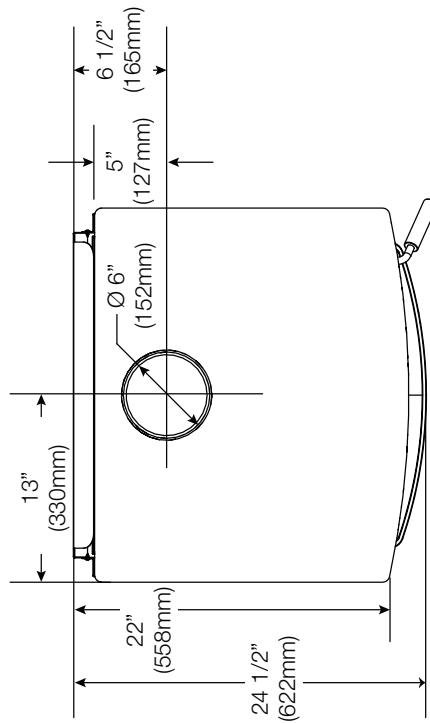

general information

1.2 specifications

Specifications	
Emissions	2.25 grams / hour
Efficiency	72%
Chamber (D.W.H)	14 5/8" x 20 7/8" x 11 5/8" (372mm x 530mm x 295mm)
Capacity	1.9 cubic feet (0.05 cubic meters)
Viewing Area	153 in ² (987cm ²)
Approx. area heated**	800-1800 square feet (74-167m ²)
Maximum heat output***	65,000 BTU /Hr
Heat output*	12,944 - 54,127 BTU /Hr
Duration low fire**	8 hours
Weight w/o bricks	210 lbs (95kg)
Weight of bricks	60 lbs (27kg)
Ideal wood length	16" (406mm)
Minimum Stack Height ****	15 feet (4.5m)
Efficiency Standard	B415.1-10

* As tested using test method ALT-125.

** Figures will vary considerably with individual conditions.

*** Wolf Steel Ltd. estimated realistic BTU/hr with hardwood logs and regular refueling.

**** Required in order to achieve proper draft.

1.3 general instructions

WARNING

- All wiring should be done by a qualified electrician and shall be in compliance with local codes. In the absence of local codes, use the current CSA C22.1 Canadian Electric Code (in Canada) or the ANSI / NFPA N° 70 National Electric Code in the United States.
 - Burning your appliance with the ash well open or the ash door ajar creates a fire hazard and may cause internal damage to the appliance or a house and/or chimney fire.
 - Do not connect this appliance to a chimney flue serving another appliance. Do not connect to any air distribution duct or system.
 - Provide adequate clearance for servicing and operating the appliance.
 - Provide adequate ventilation.
 - Never obstruct the front opening of the appliance.
 - Objects placed in front of the appliance must be kept a minimum of 48" (121.9cm) from the front face of the appliance.
 - Do not install in a mobile home.
- Before beginning your installation, consult with your local building code agency or fire officials and insurance representative to ensure compliance.
 - Non-toxic smoke will be emitted during the paint curing process, to help dissipate the smoke open a window near the appliance.
 - Remove any dust or debris off the top of the appliance before firing the appliance as the paint will become soft as the appliance heats up and will harden as the appliance cures. To cure the paint on your appliance burn your appliance moderately hot during the first few fires.
 - To keep the gasket from sticking to the appliance as the paint is curing, periodically open the door every 5-10 minutes.
 - For the first two weeks use generous amounts of fuel and burn the appliance with the damper wide open for an hour as the appliance goes through a process of eliminating moisture in the steel and firebricks. The initial heat output will be reduced while the moisture is being drawn from the appliance and it will be necessary to build several hot fires to remove this moisture. **DURING THIS PROCESS DO NOT OVERFIRE THE APPLIANCE. REDUCE THE AMOUNT OF AIR COMING INTO THE APPLIANCE IF THE APPLIANCE OR CHIMNEY BECOMES RED.**

1.4 general information

! WARNING

- Do not operate this appliance without the pedestal installed.

This appliance was specifically designed over many months of research to meet the 2020 U.S.A. EPA particulate emission standards and has been extensively tested in Canadian laboratories. This system is the most efficient, simple and trouble-free we know and works as follows:

Secondary air from the rear opening travels up the back in the secondary air housing to the manifold located at the top and shoots out laterally to oxidize the gases below the smoke exit.

The lower combustion chamber is lined with high temperature firebricks on 2 sides, the back and across the bottom, with a layer of fibre baffles at the top to maintain a high temperature in the combustion chamber so that gases mixing with the preheated air from the secondary air manifold tube are easily ignited and burned. The appliance sides and back are shielded to direct the heat upwards and forwards into the room.

Be sure to provide sufficient combustion air. There are many other appliances in your home competing for air such as: a kitchen range hood, forced air heating devices, clothes dryer or a bathroom exhaust blower.

After extended periods of non-operation such as following a vacation or a warm weather season, the appliance may emit a slight odour for a few hours. This is caused by dust particles on the firebox burning off. Open a window to sufficiently ventilate the room.

If you experience smoking problems, you may need to open a door, a window or otherwise provide some method of supplying combustion air to the appliance.

Do not use makeshift compromises during installation. Do not block or restrict air, grille, or louver openings. Do not add a hood. Burning your appliance with the door open or ajar creates a fire hazard that may result in a house and/or chimney fire.

All venting connections must be in compliance with the chimney manufacturer's installation instructions. Clearances referred to throughout this manual are the minimum requirements.

Your appliance must be installed in accordance with all national and local building code standards and the standard of Chimney and Appliances, Vents and Solid Fuel Burning Appliances NFPA #211. Consult the authority having jurisdiction (such as municipal building department, fire department, fire prevention bureau, etc.) to determine the need to obtain a permit. If you are in doubt about the proper installation for your situation, contact your dealer or local building or fire official. The manufacturer does not guarantee that this appliance and its options will completely heat your entire home.

Expansion / contraction noises during heating up and cooling down cycles are normal and to be expected.

It is recommended that in all cases, the appliance be secured to the floor.

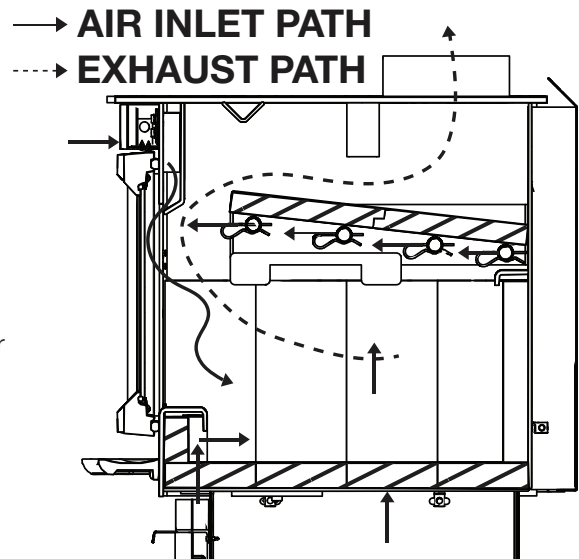

NATIONAL FIREPLACE INSTITUTE
NFI
CERTIFIED
www.nficertified.org

We suggest that our woodburning hearth products be installed and serviced by professionals who are certified in the U.S. by the National Fireplace Institute® (NFI) as NFI Woodburning Specialists or who are certified in Canada by Wood Energy Technical Training (WETT).

Wood Energy Technical Training
www.wettinc.ca

general information

1.5 rating plate information

This illustration is for reference only. Refer to the rating plate on the appliance for accurate information.

note:

The rating plate must remain with the appliance at all times. It must not be removed.



LISTED SOLID FUEL BURNING SPACE HEATER / POÊLE À COMBUSTIBLE SOLIDE HOMOLOGUÉE.
TESTED TO: / TESTÉ SELON:
UL1482 - 2011 / ULC S627 - 00
MODEL / MODÈLE: S20

THIS WOOD HEATER NEEDS PERIODIC INSPECTION AND REPAIR FOR PROPER OPERATION. CONSULT THE OWNER'S MANUAL FOR FURTHER INFORMATION. IT IS AGAINST FEDERAL REGULATIONS TO OPERATE THIS WOOD HEATER IN A MANNER INCONSISTENT WITH THE OPERATING INSTRUCTIONS IN THE OWNER'S MANUAL / CE POÊLE À BOIS DOIT ÊTRE INSPECTÉ ET RÉPARÉ PÉRIODIQUEMENT POUR UN FONCTIONNEMENT CORRECT. CONSULTEZ LE MANUEL DU PROPRIÉTAIRE POUR PLUS D'INFORMATIONS. IL EST CONTRE LES RÉGLEMENTS FÉDÉRAUX POUR FAIRE FONCTIONNER CE POÊLE À BOIS D'UNE MANIÈRE INCOMPATIBLE AVEC LES INSTRUCTIONS DE FONCTIONNEMENT DANS LE MANUEL DU PROPRIÉTAIRE.

INSTALL AND USE ONLY IN ACCORDANCE WITH WOLF STEEL LTD.'S INSTRUCTIONS. CONTACT LOCAL BUILDING OR FIRE OFFICIALS ABOUT RESTRICTIONS AND INSTALLATION INSPECTION IN YOUR AREA. MINIMUM CEILING HEIGHT: 7 FT (2.13M) USING A SINGLE WALL CONNECTOR.

HEARTH EXTENSION / COMBUSTIBLE FLOOR PROTECTION: IF INSTALLED ON A COMBUSTIBLE FLOOR, UNIT MUST BE PLACED ON A NON-COMBUSTIBLE FLOOR PROTECTOR EXTENDING 18" (455MM) (CANADA) / 16" (406MM) (U.S.A.) IN FRONT AND 8" (203MM) TO THE SIDES AND BACK.

CHIMNEY TYPE: MINIMUM 6" (152MM) DIAMETER LISTED (UL 103HT) RESIDENTIAL CHIMNEY.

CHIMNEY CONNECTOR: 6" (152MM) DIAMETER MINIMUM 24 GAUGE STEEL MINIMUM CLEARANCE FROM HORIZONTAL CONNECTOR AND CEILING 18" (455MM).

DO NOT OBSTRUCT SPACE UNDER HEATER. SPECIAL METHODS ARE REQUIRED WHEN PASSING A CHIMNEY THROUGH A WALL OR CEILING. SEE INSTRUCTIONS AND BUILDING CODES. DO NOT CONNECT THIS UNIT TO A CHIMNEY FLUE SERVING ANOTHER APPLIANCE.

WARNING: FOR USE WITH SOLID WOOD FUEL ONLY. DO NOT BURN ANY OTHER TYPE OF FUEL. DO NOT USE GRATE OR ELEVATE FIRE. BUILD WOOD FIRE DIRECTLY ON HEARTH.

WARNING: RISK OF SMOKE SPILLAGE. OPERATE ONLY WITH DOOR FULLY CLOSED. REPLACE GLASS ONLY WITH CERAMIC GLASS. DO NOT OVERFIRE. IF HEATER OR CHIMNEY CONNECTORS GLOW, YOU ARE OVERFIRING. INSPECT AND CLEAN CHIMNEY FREQUENTLY. UNDER CERTAIN CONDITIONS OF USE CREOSOTE BUILD-UP MAY OCCUR RAPIDLY.

OPTIONAL BLOWER KIT: NEP70, 115V, 60HZ, 0.82AMP, ROUTE CORD AWAY FROM UNIT.

DANGER: RISK OF ELECTRICAL SHOCK. DISCONNECT POWER BEFORE SERVICING UNIT.

POUR INSTALLATION ET UTILISATION CONFORMEMENT AUX INSTRUCTIONS DE WOLF STEEL L.T.E.E. RENSEIGNEZ-VOUS AUPRÈS DES AUTORITÉS LOCALES DU BÂTIMENT OU DU SERVICE DES INCENDIES AU SUJET DES RESTRICTIONS ET DES INSPECTIONS D'INSTALLATION DANS VOTRE RÉGION. HAUTEUR DE PLAFOND MINIMAL: 7' (2,13M) EN UTILISANT UN TUYAU DE RACCORDEMENT À PARI SIMPLE.

BASE DE PROTECTION / PROTECTION DU PLANCHER COMBUSTIBLE: SI INSTALLÉ SUR UN PLANCHER COMBUSTIBLE, L'APPAREIL DOIT ÊTRE PLACÉ SUR UNE PLAQUE PROTECTRICE INCOMBUSTIBLE S'ÉTENDANT SUR 18" (455mm) (CANADA) / 16" (406mm) (E.U.) À L'AVANT ET 8" (203mm) À L'ARRIÈRE ET SUR LES CÔTÉS.

TYPE DE CHEMINÉE: CHEMINÉE RESIDENTIELLE DE 6" DE DIAMÈTRE (152MM) HOMOLOGUÉE (UL 103HT).

RACCORD DE CHEMINÉE: DIAMÈTRE DE 6" (152MM) D'ACIER DE CALIBRE 24 MINIMUM. 18" (455MM) DE DÉGAGEMENT MINIMAL ENTRE LE RACCORD HORIZONTAL ET LE PLAFOND.

NE RIEN ENTREPOSER SOUS LE CHAUFFAGE. DES MÉTHODES SPÉCIALES SONT REQUISES LORSQUE UNE CHEMINÉE TRAVERSE UN MUR OU UN PLAFOND. VOIR LES INSTRUCTIONS ET LES CODES DU BÂTIMENT. NE PAS RACCORDER À LA CHEMINÉE D'UN AUTRE APPAREIL.

AVERTISSEMENT: POUR L'USAGE AVEC LE BOIS SEULEMENT. NE BRÛLEZ PAS D'AUTRE TYPE DE COMBUSTIBLE. N'UTILISEZ PAS DE CHENET OU NE SURELÈVEZ PAS LE BOIS. PRÉPAREZ LE FEU DIRECTEMENT SUR LA TÊTE.

AVERTISSEMENT: RISQUE D'ÉCHAPPEMENT DE FUMÉE. TENIR LA PORTE FERMÉE LORSQUE LE POÊLE FONCTIONNE. REMPLACEZ LA VITRE PAR UNE VITRE EN CÉRAMIQUE SEULEMENT. SURCHAUFFEZ PAS L'APPAREIL. NE PAS REMPLACER LES RACCORDS EN CÉRAMIQUE. L'APPAREIL SURCHAUFFÉ, INSPECTEZ ET NETTOYEZ LA CHEMINÉE FREQUENTEMENT. DANS CERTAINES CONDITIONS, DES DÉPÔTS DE CRÉOSOTE PEUVENT SE FORMER RAPIDEMENT.

SOUFFLERIE OPTIONNELLE: NEP70, 115V, 60HZ, 0.82A. TENEZ LE CORDON ÉLECTRIQUE LOIN DE L'APPAREIL.

DANGER: RISQUE DE SECOURS ÉLECTRIQUE. DÉBRANCHEZ AVANT DE PROCÉDER À L'ENTRETIEN.

PARALLEL & CORNER / PARALLÈLE & COIN		SINGLE WALL CONNECTOR / TUYAU DE RACCORDEMENT À PARI SIMPLE	DOUBLE WALL CONNECTOR / TUYAU DE RACCORDEMENT À PARI DOUBLE	DOUBLE WALL CONNECTOR + LOW CLEARANCE COMBUSTIBLE KIT / TUYAU DE RACCORDEMENT À PARI DOUBLE - ENSEMBLE DE COMBUSTIBLE À DÉGAGEMENT BAS*
Sidewall / mur de côté (A)	13" (33cm)		12" (30.5cm)	
Sidewall to flue / mur de côté à la buse (B)	22 7/8" (58.1cm)		21 1/2" (54.6cm)	
Backwall / mur arrière (C)	11 1/2" (29.2cm)		9 1/2" (24.1cm)	5 1/2" (14cm)
Backwall to flue / mur arrière à la buse (D)	15" (38.1cm)		12 1/2" (31.8cm)	8 1/2" (21.6cm)
Corner / coin (E)	11" (27.9cm)		7" (17.8cm)	
Ceiling / plafond (F)			84" (213.4cm)	

ALCOVE / ALCÔVE	
Ceiling / plafond (G)	N/A
Sidewall / mur de côté (H)	75" (190.5cm)
Sidewall to flue / mur de côté à la buse (I)	N/A
Sidewall to flue / mur de côté à la buse (J)	19" (48.3cm)
Backwall / mur arrière (K)	28 7/8" (73.3cm)
Backwall to flue / mur arrière à la buse (L)	N/A
Backwall to flue / mur arrière à la buse (M)	12 1/2" (31.8cm)
Backwall to flue / mur arrière à la buse (N)	N/A
Backwall to flue / mur arrière à la buse (O)	16" (40.6cm)

MINIMUM FLOOR PROTECTION / PROTECTION MINIMAL DU PLANCHER		
FRONT / ÉLEVANT (L)	SIDES / CÔTES (M)	BACK / ARRIÈRE (N)
CANADA	18" (45.7cm)	8" (203mm)
USA / E.U.	16" (40.6cm)	8" (203mm)

* Only applicable with the use of low clearance combustion kit RCHS20. See "accessories" section of your installation manual for more information. / Seulement applicable avec l'utilisation de l'ensemble de combustion à dégagement bas RCHS20. Voir la section « accessoires » dans votre manuel d'installation pour plus d'information.

Clearances can be reduced with shielding acceptable to local authorities. Reduced installation must comply with NFPA 211 or CAN/CSA-B365. / Il est possible de réduire les dégagements à l'aide d'un protecteur conforme aux normes des autorités locales. Une installation réduite doit être conforme aux normes NFPA 211 ou au CAN/CSA-B365.

MANUFACTURE DATE: / DATE DE FABRICATION:

YEAR/ANNÉE: 2019 2020 2021 2022 2023 2024

MONTH/MOIS: 1 2 3 4 5 6 7 8 9 10 11 12



CAUTION:
ATTENTION:

HOT WHILE IN OPERATION. DO NOT TOUCH. KEEP CHILDREN, CLOTHING AND FURNITURE AWAY. CONTACT MAY CAUSE SKIN BURNS. SEE NAMEPLATE AND INSTRUCTIONS.
QUAND L'APPAREIL FONCTIONNE, LA SURFACE DEVIENT CHAUDE. NE PAS TOUCHER. TENIR LES ENFANTS, LES VÊTEMENTS ET LES MEUBLES À L'ÉCART. LE CONTACT PEUT CAUSER DES BRÛLURES À LA PEAU. VOIR LA PLAQUE D'HOMOLOGATION ET LES INSTRUCTIONS.

WOLF STEEL LTD.
 24 NAPOLEON ROAD, BARRIE, ON
 L4M 0G8 CANADA

WOLF STEEL USA
 103 MILLER DRIVE, CRITTENDEN, KY
 401030 USA

NAC GUANGZHOU P.R.C.
 NO.69 HEFENG ROAD, GUANGZHOU, CHINA

S20

W385-4531 / A

2.1 appliance placement

We recommend having your Napoleon wood burning appliance installed by a qualified technician. However, should you choose to install the appliance yourself, it is extremely important that you follow all installation instructions for the appliance, the chimney and connector if applicable, as well as local building codes. At the very least, draw a detailed plan of your installation, including clearance dimensions to combustibles, and have your authorized dealer review them to confirm that they conform to the relative installation parameters.

note:

When positioning the appliance, it may be necessary to adjust its position to prevent the chimney/vent system from intersecting with a framing member and to meet the minimum combustible clearance requirements. Its location should also avoid the potential for drapes or doors to swing within 48" (122cm) in front of the appliance to prevent a fire hazard.

2.2 pedestal back plate installation

1. Place the back plate in position, ensuring the holes in the back plate align with the holes in the appliance (**Fig. 2-1**).
2. Install two screws (supplied) to secure the back plate in position (**Fig. 2-2**).

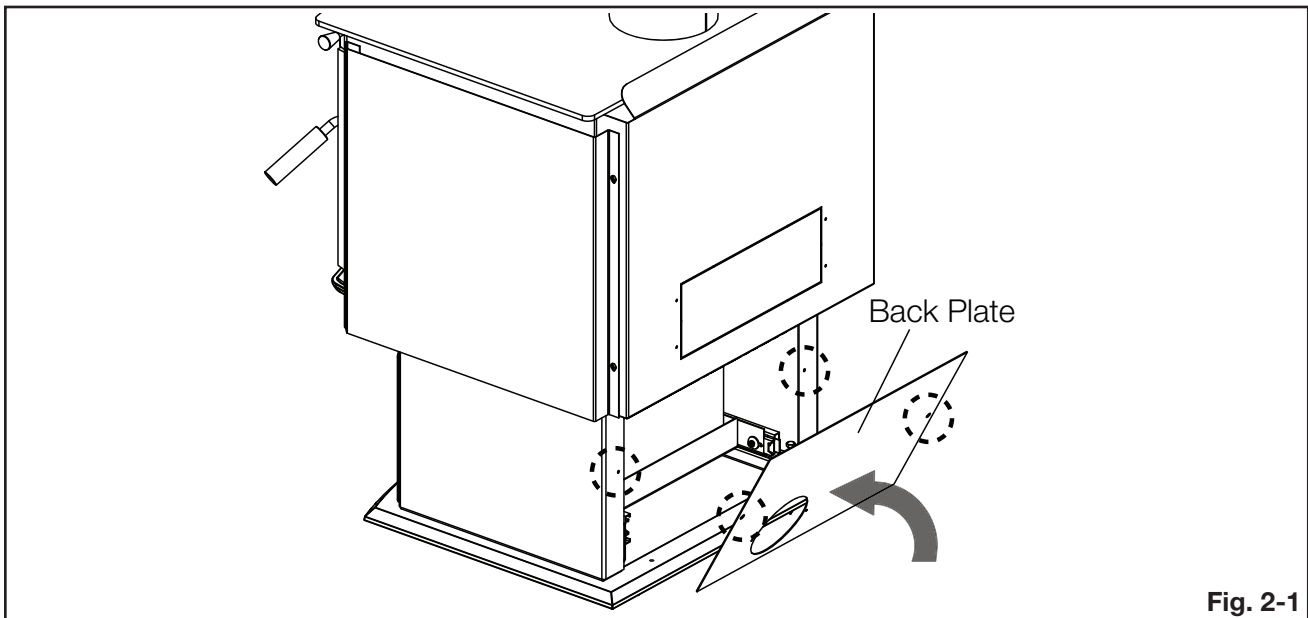

Fig. 2-1

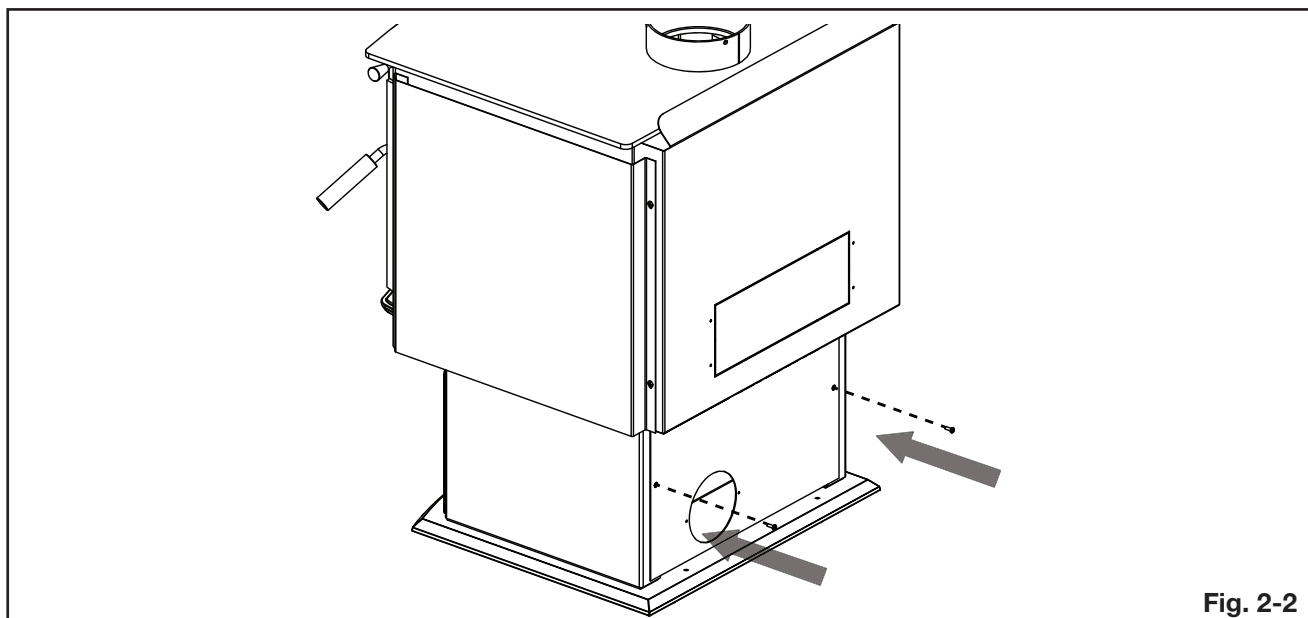

Fig. 2-2

installation planning

2.3 minimum clearance to combustibles

! WARNING

- Do not install into any area having less than 7 feet (2.1m) (ceiling to appliance bottom, excluding hearth height).

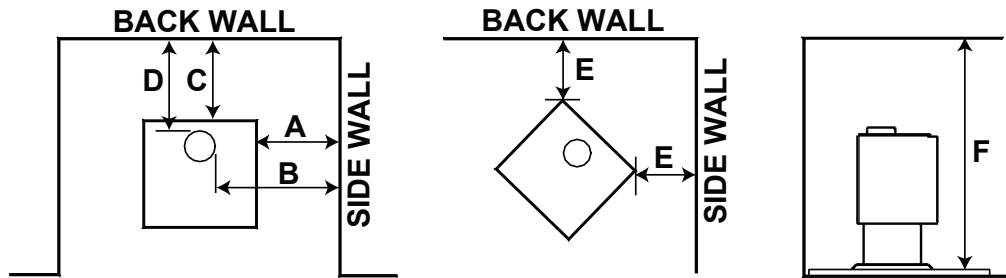

PARALLEL & CORNER	SINGLE WALL CONNECTOR	DOUBLE WALL CONNECTOR	DOUBLE WALL CONNECTOR + DOUBLE BACK SHIELD AND TOP SHIELD *
Sidewall (A)	13" (33cm)	12" (30.5cm)	
Sidewall to flue (B)	22 7/8" (58.1cm)	21 1/2" (54.6cm)	
Backwall (C)	11 1/2" (29.2cm)	9 1/2" (24.1cm)	5 1/2" (14cm)
Backwall to flue (D)	15" (38.1cm)	12 1/2" (31.8cm)	8 1/2" (21.6cm)
Corner (E)	11" (27.9cm)	7" (17.8cm)	
Ceiling (F)	84" (213.4cm)		
Clearances can be reduced with shielding acceptable to local authorities. Reduced installation must comply with NFPA 211 or CAN/CSA-B365.			

note:

* Only applicable with the use of low clearance combustion kit RCHS20. See "accessories" section for more information.

2.4 alcove installation

Your appliance may be installed using a listed double wall connector (such as Security DL6 in Canada, the Simpson Duravent Plus DVL in the USA, or an equivalent double wall connector) into an alcove having a depth of no more than 4 feet (1.2m) and a height of at least 6'3" (1.8m x 76mm). The minimum clearances are as shown.

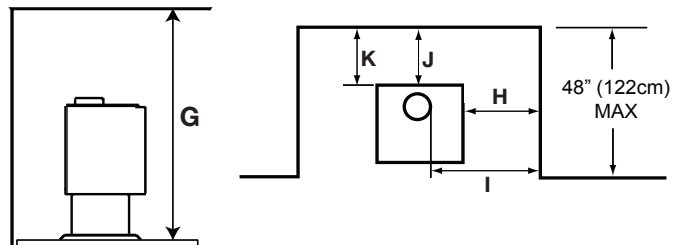

ALCOVE		
PARALLEL & CORNER	SINGLE WALL CONNECTOR	DOUBLE WALL CONNECTOR
Ceiling (G)	N/A	75" (190.5cm)
Sidewall (H)		19" (48.3cm)
Sidewall to flue (I)		28 7/8" (73.3cm)
Backwall (J)		12 1/2" (31.8cm)
Backwall to flue (K)		16" (40.6cm)

2.5 floor protection

If the appliance is to be installed on top of a combustible floor, it must be placed on an approved non-combustible hearth pad, that extends 8" (203mm) beyond the appliance sides and back, and 18" (45.7cm) in Canada / 16" (40.6cm) in the USA to the front. The reduced clearance from the back of the appliance may result in the appliance pad terminating shorter than 8" (203mm) beyond the appliance.

note:

Floor protection is required for spark and ash shielding, but not for limiting floor temperatures from the radiant heat of the appliance. The appliance was designed and safety-tested so that without any protection, the floor would not overheat.

Refer to local building codes for suitable floor protection materials.

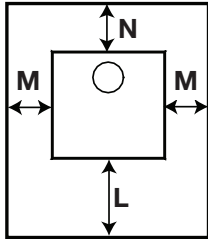

MINIMUM FLOOR PROTECTION			
	FRONT (L)	SIDES (M)	BACK (N)
CANADA	18" (45.7cm)	8" (203mm)	
USA	16" (40.6cm)	8" (203mm)	

note:

If a section of horizontal chimney connector is used, floor protection is required under the chimney connector and 2" (51mm) beyond each side.

2.6 outside air

The following are signs that fresh air may be required for the appliance to better function:

- When there is combustion present, wood burns poorly, smoke spills, back-draft takes place, and your chimney does not draw steadily.
- In the winter, there is too much condensation on the windows.
- Opening a window seems to alleviate the above symptoms.
- A ventilation system is installed in the house.
- Other devices are present that exhaust house air.
- The house has tight fitting windows and/or is equipped with a well-sealed vapour barrier.

Systems such as HRV's are designed to bring fresh air into your home and will resolve these related performance issues with your appliance.

If outside air is brought directly to the appliance, a damper allowing 100% closure shall be used (not supplied). The air inlet must prevent material from dropping into the inlet and also prevent rodents from entering from the outside (a wire mesh having openings not larger than 1/4" by 1/4" [6.4mm by 6.4mm] is sufficient).

3.0 installation

WARNING

- Wear gloves, protective footwear and safety glasses for protection.
- Carefully follow the instructions for assembly of the pipe and other parts needed to install the appliance. Failure to do so may result in a fire, especially if combustibles are too close to the appliance or chimney and air spacers are blocked, preventing the free movement of cooling air.
- Do not draw outside air from garage spaces. Exhaust products of gasoline engines are hazardous. Do not install outside air ducts such that the air may be drawn from attic spaces, basements or above the roofing where other heating appliances or fans and chimneys exhaust or utilize air. These precautions will reduce the possibility of appliance smoking or air flow reversal. The outside air inlet must remain clear of leaves, debris, ice and/or snow. It must be unrestricted while appliance is in use to prevent room air starvation which can cause smoke spillage and an inability to maintain a fire. Smoke spillage can also set off smoke alarms.
- Negative pressure within your home may inadvertently affect your appliance.
- To prevent contact with sagging or loose insulation, the appliance must not be installed against vapour barriers or exposed insulation. Localized overheating could occur and a fire could result.
- Do not use makeshift compromises during installation. Do not block or restrict air, grille or louvre openings. Do not add a hood.
- To prevent personal injury, keep hand tools in good condition, sharpen cutting edges and make sure tool handles are secure.
- Always maintain the minimum air space required in the enclosure to prevent fires.
- Check with local building officials for any permits required for installation of this appliance and notify your insurance company prior to proceeding.

3.1 chimney

WARNING

- Never install a single wall slip section or smoke pipe in a chase structure. The higher temperature of this single wall pipe may radiate sufficient heat to combustible chase materials to cause a fire.
- Do not connect this appliance to a chimney system serving another appliance.
- To avoid danger of fire, all instructions must be strictly followed, including the provision of air space clearance between chimney system and enclosure. To protect against the effects of corrosion on those parts exposed to the weather, we recommend that the chase top be painted with a rust-resistant paint.
- Do not fill any framed space around the chimney with insulation or any other material. Insulation placed in this area could cause adjacent combustibles to overheat.
- Maintain a minimum 2" (51 mm) air clearance to all parts of the chimney system at all times (this excludes the chimney connection). Failure to maintain this 2" (51mm) air clearance will cause a structure fire. Never fill this space with any type of material.
- Detailed instructions for installation of the chase top, storm collar and termination cap are packaged with these parts.
- Do not cut rafters or ceiling joists without first consulting a building official to ensure structural integrity is not compromised.
- Firestop spacers must be used whenever the chimney penetrates a ceiling/floor area.
- The total horizontal vent length should not exceed 40% of the chimney height above the appliance all horizontal smoke pipe must slope slightly upwards a minimum of 1/4" (6.4mm) per foot and all connections must be tight and secured by three sheet metal screws equally spaced. An uninsulated smoke pipe shall not pass through an attic, roof space, closet or similar concealed space, or through a floor, ceiling, wall or partition, or any combustible constructions.
- Do not use any makeshift materials during installation.

Your appliance may be connected to a factory built or masonry chimney. If you are using a factory built chimney, it must comply with ULCS629 (Canada) or UL103 (USA) standards. It must therefore be a 6" (152mm) HT Type (2100°F) chimney. It is extremely important that it be installed according to the manufacturer's specifications. The manufacturer's installation instructions and specified clearances should always be followed in accordance with local and national codes. In Canada the CSA B365 and the CSA C22.1 installation codes are to be followed. In the USA the ANSI NFPA 70 and ANSI NFPA 211 installation codes are to be followed.

Chimney and chimney connector must be in good condition and kept clean.

installation

3.1.1 chimney connection

Your chimney connector and chimney must have the same diameter as the appliance's exhaust flue outlet. The appliance pipe must be made of aluminized or cold roll steel with a minimum 24 gauge (0.6mm) thickness. It is strictly forbidden to use galvanized steel.

A 6" (152.4mm) diameter single or double wall chimney connector, used to connect the appliance to the chimney, must be installed with the crimped end toward the appliance. This will ensure that the moisture which condenses from the burning wood will flow back into the fire chamber. Each joint in the chimney connector must be secured with at least three sheet metal screws, equally spaced around the circumference.

For installation of your chimney connector, the following recommendations may be useful:

- The chimney connector must be short and straight. For optimum performance, it is recommended that all horizontal runs have a minimum 1/4" (6mm) rise per foot (0.3m), with the higher end of the section toward the chimney. For safe and proper operation of the appliance, see the "installation" section.
- To ensure a good draft, the total horizontal length of the connector should never exceed 8' (2.4m) to 10' (3.1m). In the case of vertical installation, the total length of the connector can be longer and connected without problem to the chimney at the ceiling level.
- There should never be more than two 90° elbows in the entire connector and chimney system. Never start with a 90° elbow. Always go up vertically for at least 2 feet (0.6m) from the flue collar before using a 90° elbow.
- The connector must not pass through any combustible material, nor may it pass through a concealed space (such as an attic, roof space, or closet). If passing through a wall, ceiling or into a masonry chimney, use either chimney components listed for that specific use, or means acceptable to local authorities having jurisdiction over the installation.

This appliance must be connected to:

- A. A chimney complying with the requirements for Type HT chimneys in the Standard for Chimneys, Factory-Built, Residential Type and Building Heating Appliance
- OR
- B. A code-approved masonry chimney with a flue liner. Vent the stove into a masonry chimney or an approved, insulated solid-fuel stainless-steel chimney with as short and straight a length of 6" (152mm) diameter chimney connector as possible. Connection to a masonry thimble cemented in place.

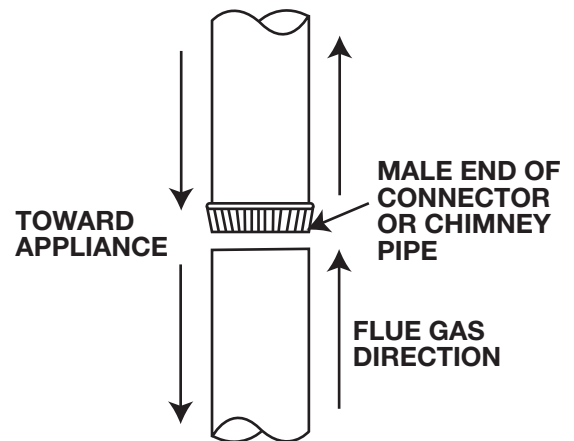

3.1.2 adding sections

Add chimney sections, according to the manufacturer's installation instructions. If the chimney system passes through an attic space, a rafter radiation shield or attic insulation shield is required. The chimney must extend at least 3ft (0.9m) above its point of contact with the roof and at least 2ft (0.6m) higher than any wall, roof or building within 10ft (3.1m). If the chimney extends more than 5ft (1.5m) above the roof, it must be secured using a roof brace or guide wires. A raincap must be installed to avoid internal damage and corrosion.

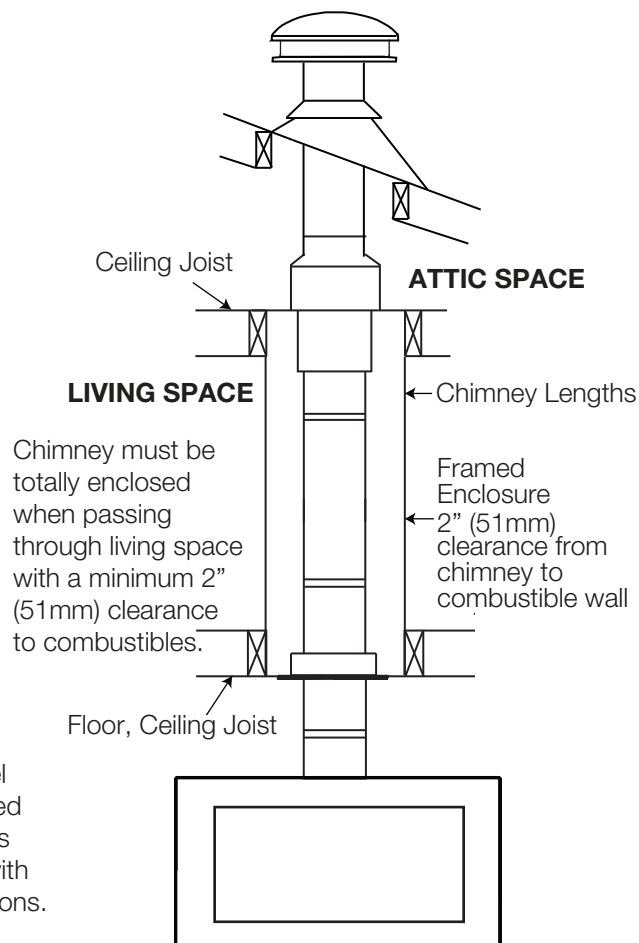
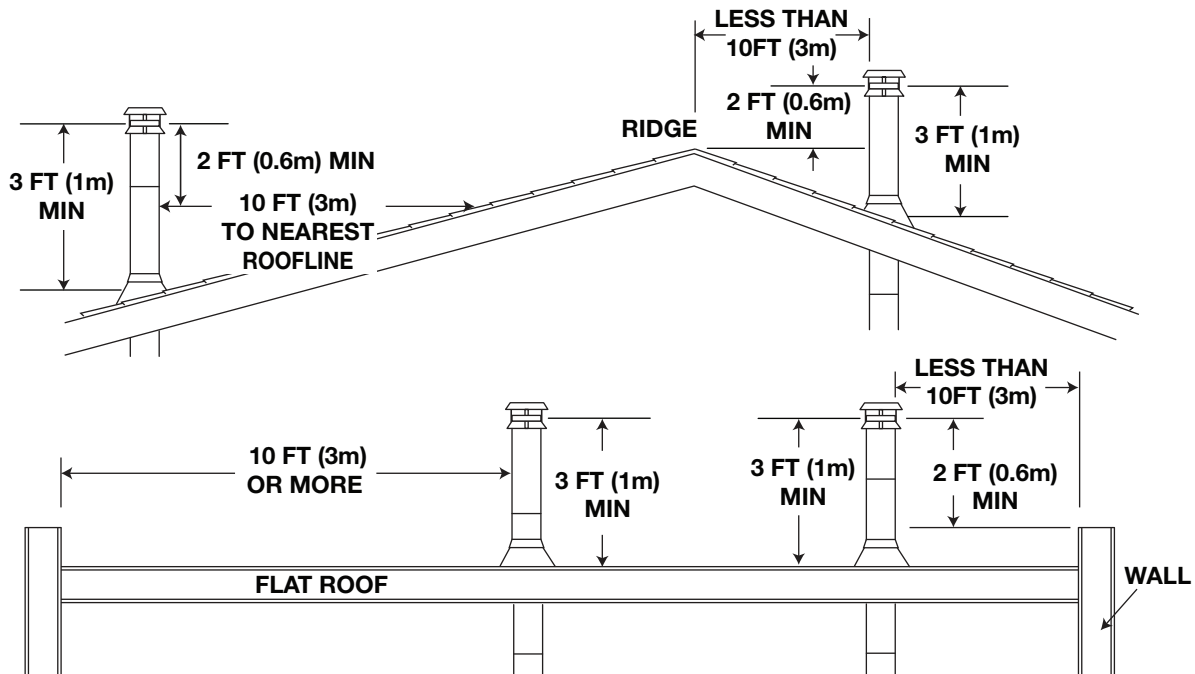

An insulated stainless steel chimney must be supported at the ceiling or roof and its installation must comply with its manufacturer's instructions.

installation

3.1.3 typical through the ceiling

- A. Move the stove into position with the flue centered, midpoint between two joists to prevent having to cut them. Use a plumb bob to line up the center.
- B. Cut and frame an opening in the ceiling to provide a 2" (50.8mm) clearance between the outside of the chimney and any combustible material. **Do not fill this space with any type of material.** Nail headers between the joist for extra support. Firestop spacers must be placed on the bottom of each framed opening in any floor or ceiling that the chimney passes through. If your chimney system is enclosed within the attic area, a rafter radiation shield is required.
- C. Hold a plumb bob from the underside of the roof to determine where the opening in the roof should be. Cut and frame the roof opening to maintain proper 2" (50.8mm) clearances.

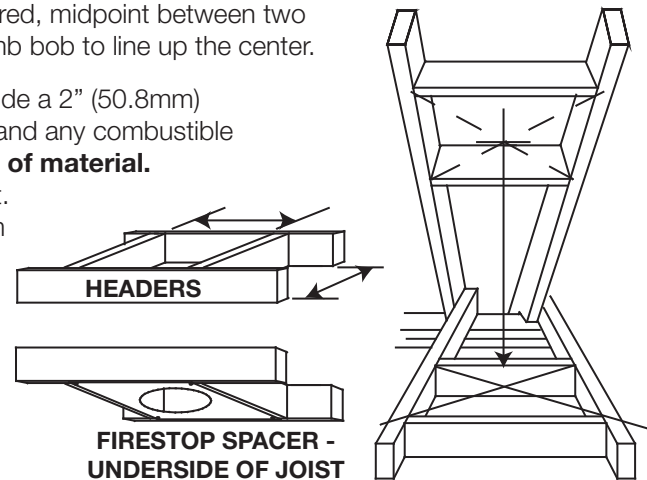

note:

The chimney must be supported at the ceiling or roof so that its weight does not rest on the appliance and must comply with its manufacturer's instructions.

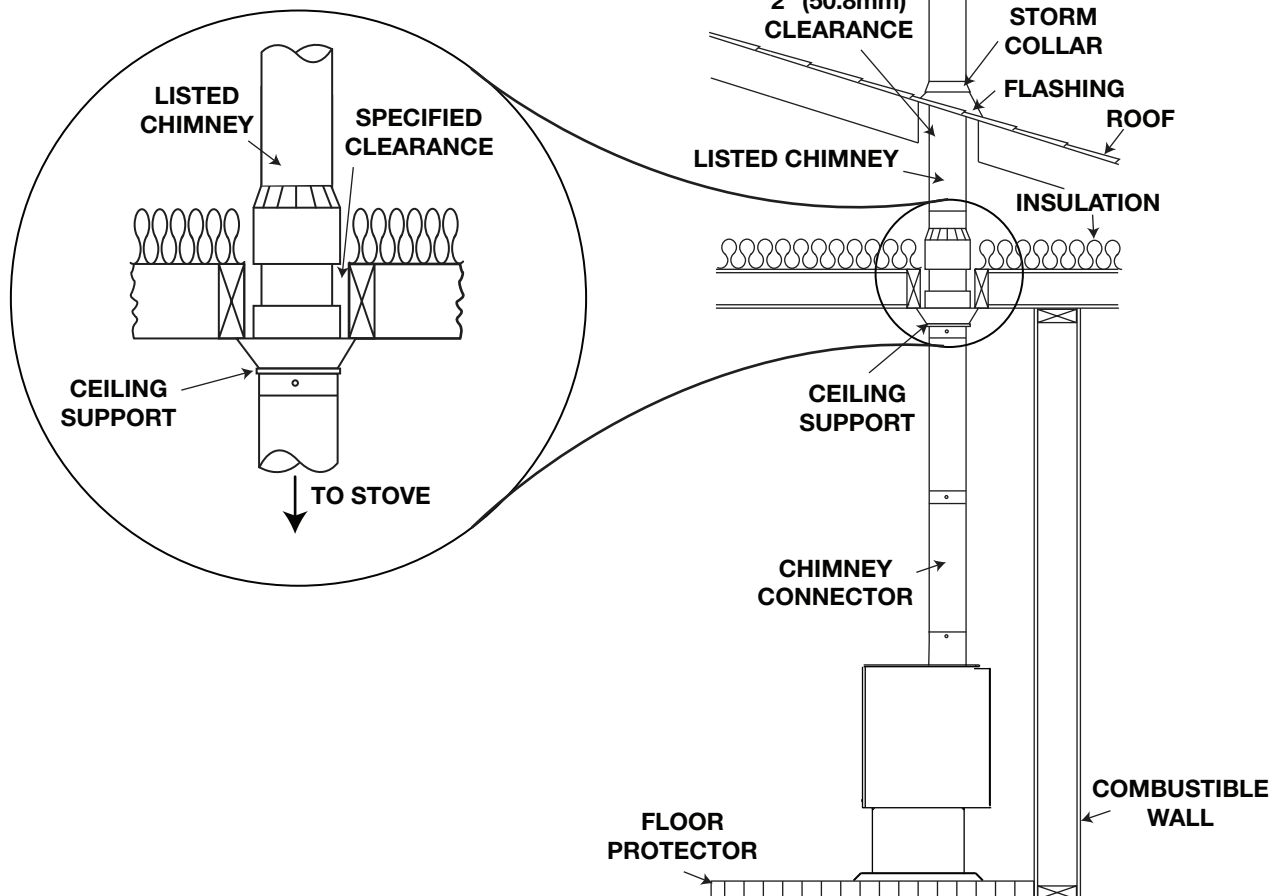

3.1.4 typical through the wall

If possible, design the installation so that the connector does not pass through a combustible wall. If during your installation you must pass through a combustible wall, check with your building inspector before you begin. Also check with the chimney connector manufacturer for any specific requirements.

Consult with your dealer regarding special connection components available for use for wall pass-throughs. Use only parts that have been tested and listed for use in a wall pass-through.

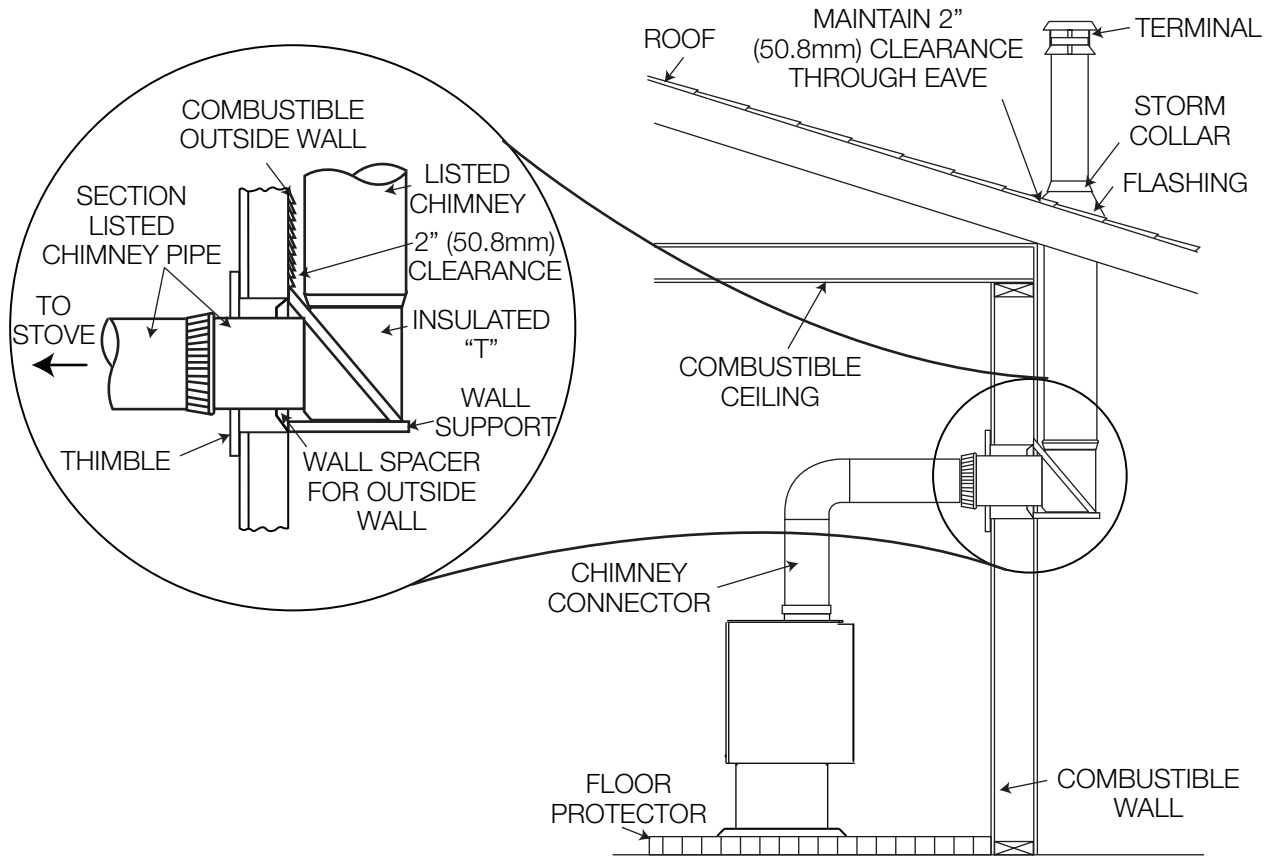

3.1.5 typical existing masonry

You can also install your appliance using your existing masonry chimney. To do so, use the following guidelines. Use a factory-built thimble, or construct your own brick thimble. If you are using a masonry chimney, it is important that it be built in compliance with the specifications of the Building Code in your region. It must normally be lined with fire clay bricks, metal or clay tiles sealed together with fire cement. (Round flues are the most efficient). The maximum flue size is 8" (203.2mm) x 8" (203.2mm) square or 6" (152.4mm) round. For greater diameters it is necessary to install a 6" (152.4mm) stainless steel liner.

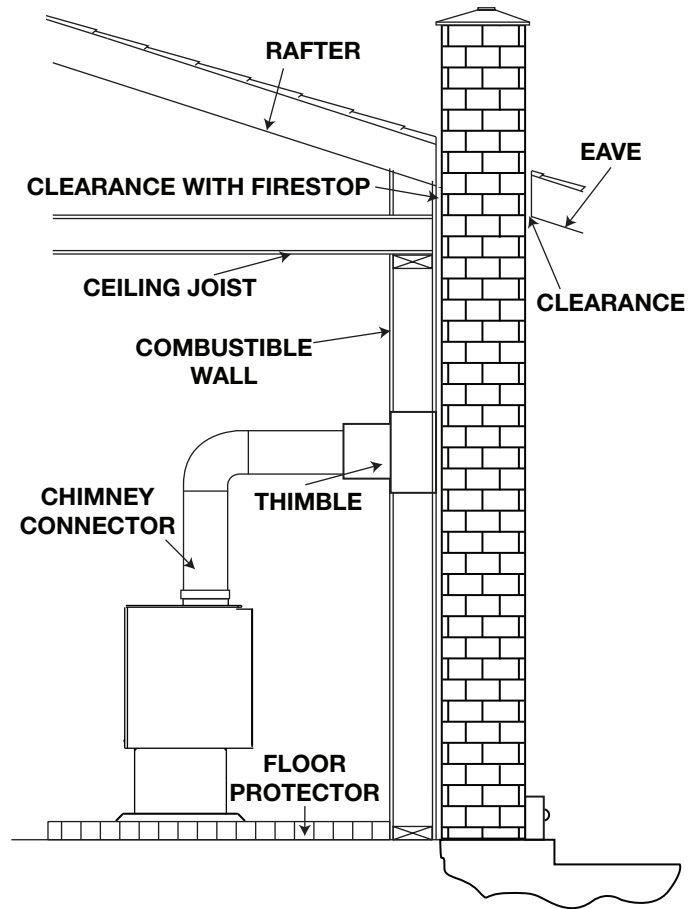

4.1 door removal

! WARNING

- Burning your appliance in with the doors open or ajar creates a fire hazard that may result in a house and/or chimney fire.
- Do not strike or slam door.
- Never remove the door when the appliance is hot.

note:

We strongly recommend using two people to remove and/or install the appliance door as it is very heavy.

1. With one hand on the door to prevent it from falling, open the door and remove the 6 large screws located on the hinges (**Fig. 4-1**).
2. Remove the door, placing it face down on a soft, non-abrasive surface (**Fig. 4-2**). Be careful not to scratch the paint.
3. Reverse these steps to install the door.

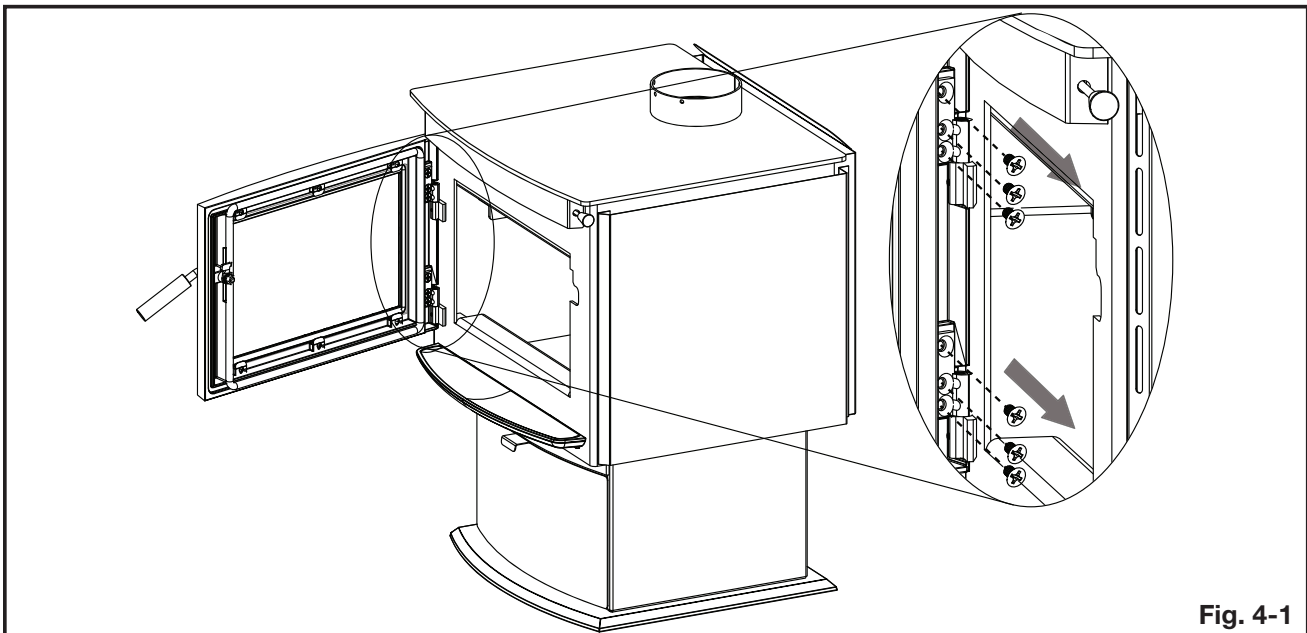

Fig. 4-1

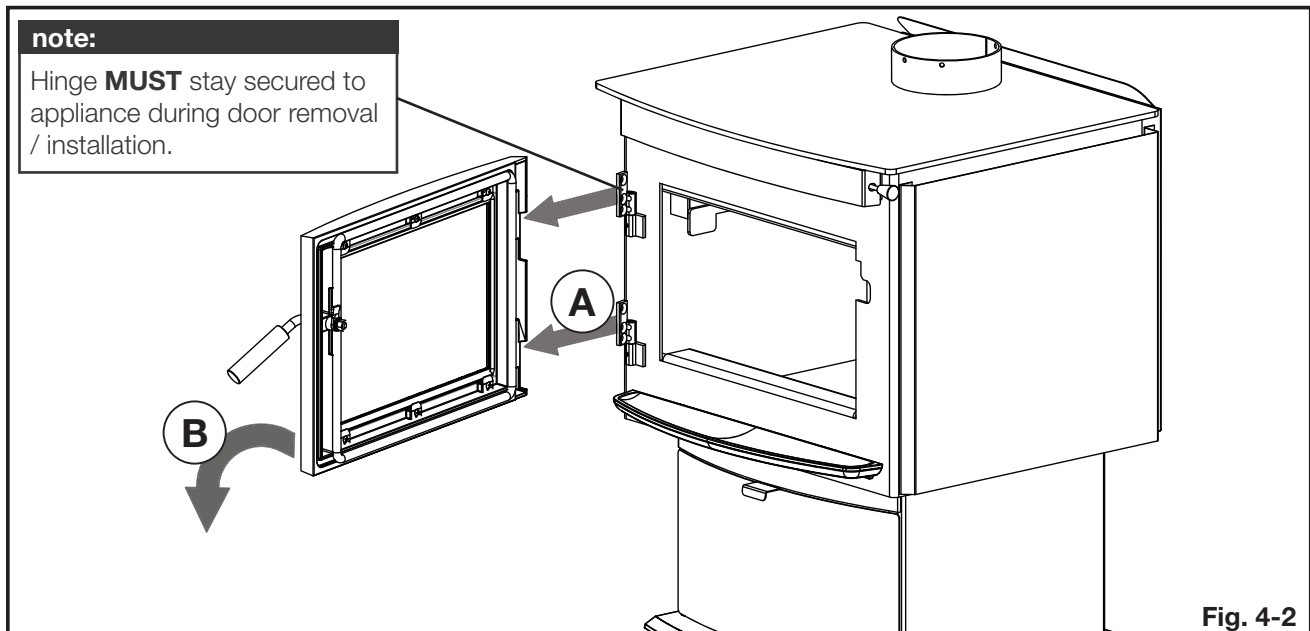

Fig. 4-2

4.2 door adjustment

note:

This hinge pin is an offset cam, which means it can move the door away from or closer to the firebox face, either creating a gap between it and the door gasket or making the door fit too tight. Adjust accordingly.

1. After removing and reinstalling the door (see "door removal" section), the door may not be level. In this case, door adjustment may be necessary.
2. To align the door, loosen the set screws. Rotate the hinge pins clockwise or counter-clockwise to raise or lower the opposite end of the door. Tighten the set screw.

note:

Door adjustment is strictly trial and error; you may need to perform this adjustment a few times until the desired door angle is attained.

3. Ensure the door latch closes and engages properly.

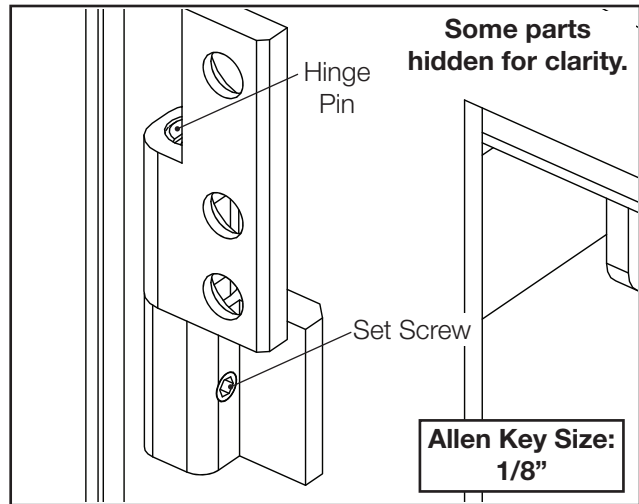

4.3 door handle installation

! WARNING

- Burning your appliance in with the doors open or ajar creates a fire hazard that may result in a house and/or chimney fire.
- Do not strike or slam door.
- Never remove the door when the appliance is hot.

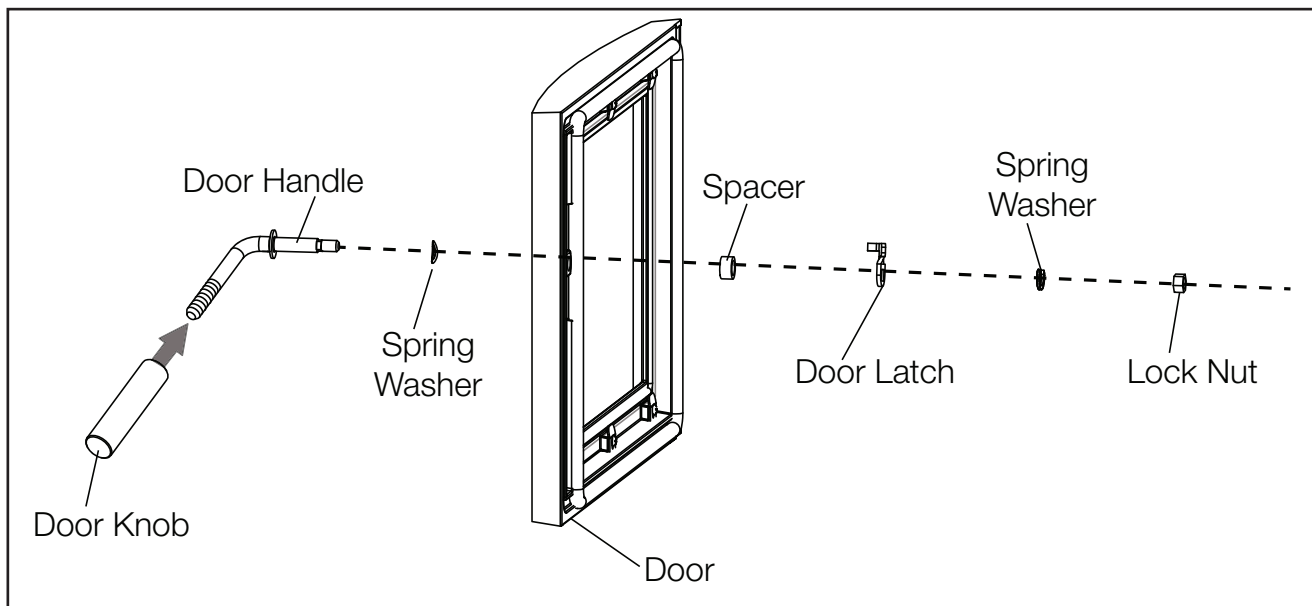
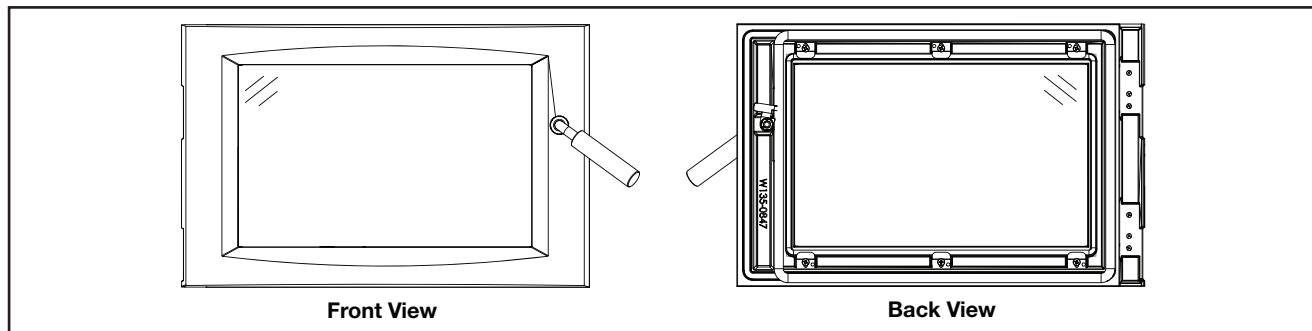

4.4 brick and baffle installation

! WARNING

- Operation of the appliance without the bricks and baffles can result in excessive temperatures that could damage the appliance, chimney and the surrounding enclosure.

With the appliance and chimney installation completed, move the bricks into place as illustrated below (**Fig. 4-3**).

- Install nine (A) bricks and one (B) brick along the bottom of the firebox, working from the back of the appliance forward.
- Install eight (A) bricks along the left and right sides of the appliance.
- Install four (A) bricks and one (C) brick along the back wall by pivoting the bricks up under the brick retainer.

note:

Place brick (C) in the centre, with two (A) bricks on either side as illustrated (**Fig. 4-3**).

- Carefully pivot fibre baffles (D) up onto the secondary air tubes as illustrated (**Fig. 4-4**). Ensure that the top baffles are pushed all the way to the rear of the firebox, leaving a minimum of a 1 inch gap along the front. This will allow the flue gases to escape the firebox. Ensure overlap joint is tight.
- Install the two (E) bricks along the front.

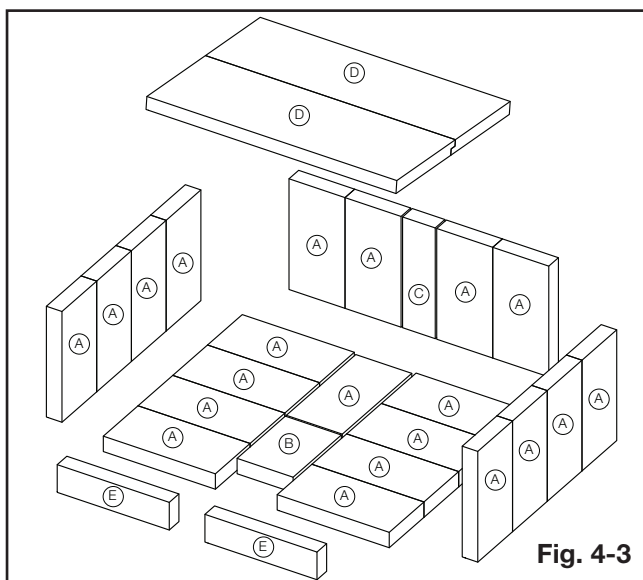

Fig. 4-3

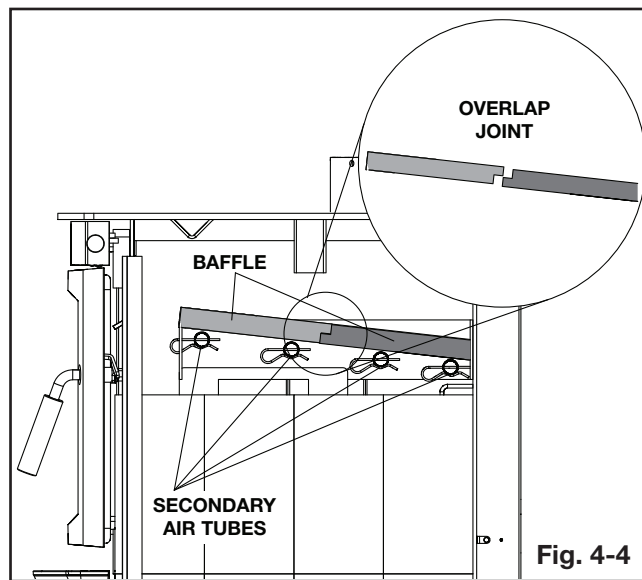

Fig. 4-4

note:

The fibre baffles are shipped inside the firebox. They must be removed from all special packaging prior to installation.

For further details about brick descriptions and part numbers, see "replacement parts" section.

4.5 secondary air tubes

note:

The back 3 secondary air tubes are factory-installed; therefore only the front secondary air tube (supplied inside the firebox) will need to be installed.

Before beginning installation, note the correct orientation of the secondary air tube. The side with the notch should face to the right, while the side with 2 holes on the end should face to the left.

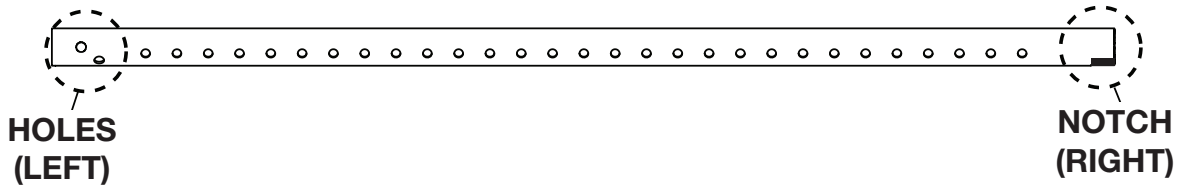

1. With the appliance door open or removed, insert the left side of the secondary air tube into the hole in the **left side** of the appliance.
2. Insert the right side of the secondary air tube into the hole in the **right side** of the appliance. Ensure the notch makes contact with the pin (**Fig. 4-5**).
3. Align the hole in the secondary air tube with the hole in the bracket inside the left side of the firebox, and then insert a cotter pin (supplied) (**Fig. 4-6**).
4. Spread the cotter pin to retain the secondary air tube in place.

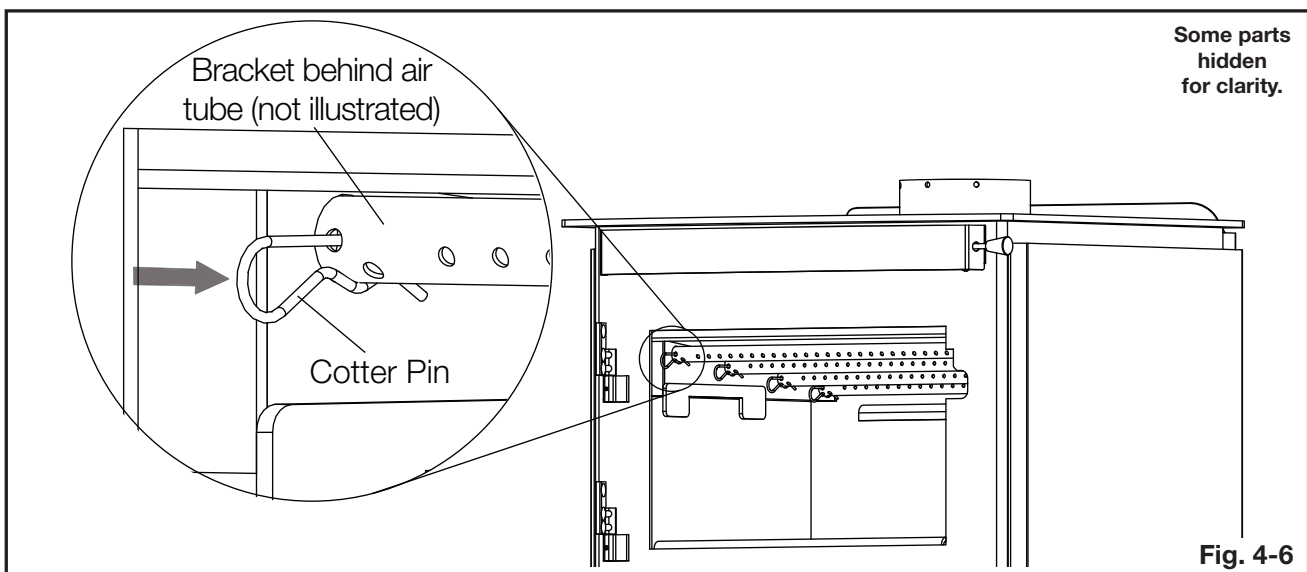
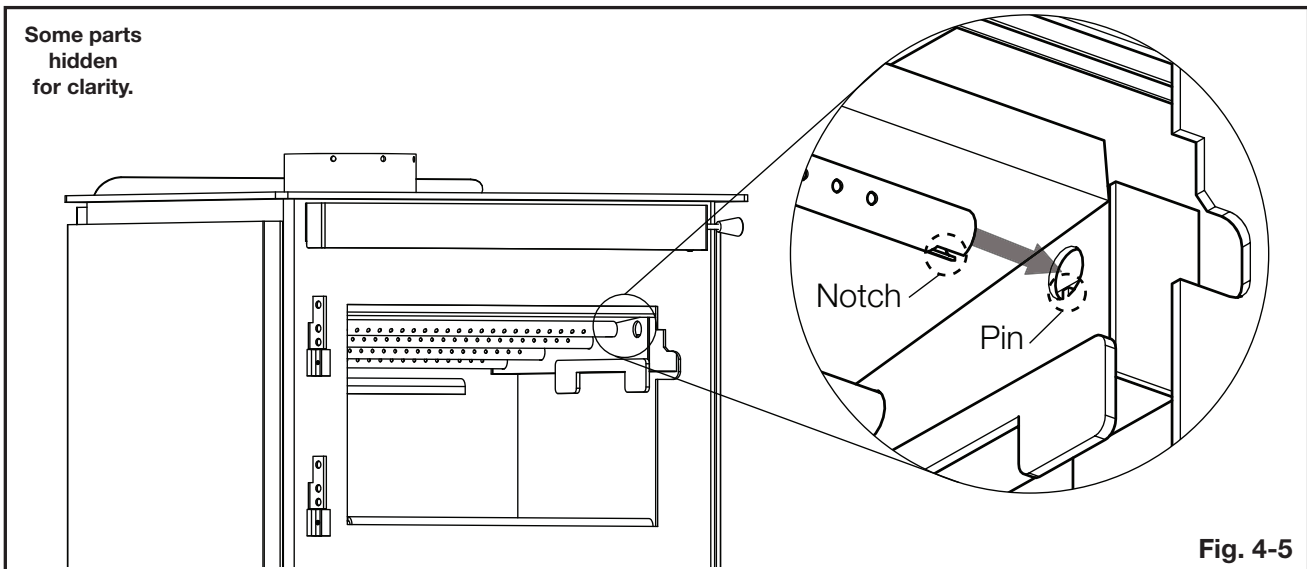

4.6 ash lip removal / installation

! WARNING

- To avoid injury or damage, do not lift or carry the appliance using the ash lip.

note:

The ash lip comes factory-installed.

- Remove the 2 screws securing the ash lip to the appliance.
- Set screws and ash lip aside.
- Reverse these steps to install the ash lip.

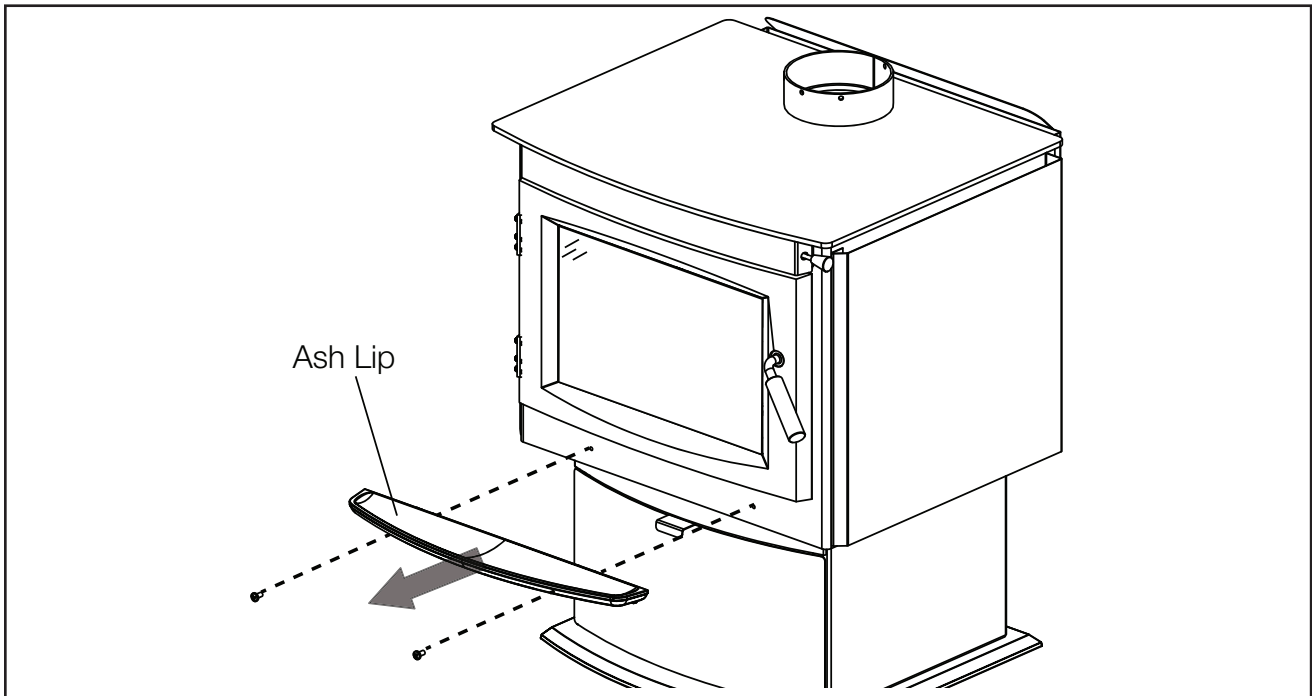

4.7 logo placement

Remove the backing of the logo supplied and place, as illustrated.

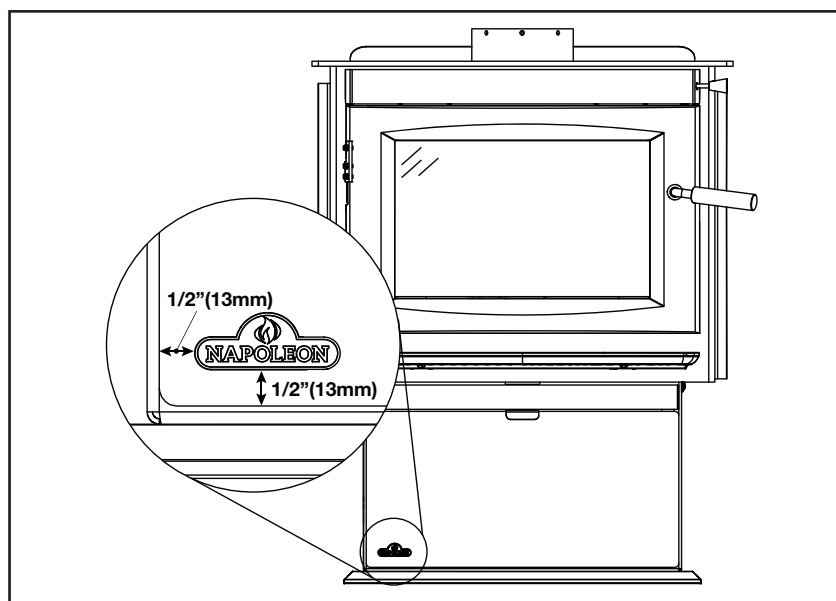

5.0 optional installation

5.1 blower kit installation

! WARNING

- Risk of fire and electrical shock!
- Turn off the gas and electrical power before servicing this appliance.
- Use only Wolf Steel approved optional accessories and replacement parts with this appliance. Using non-listed accessories (blowers, doors, louvres, trims, gas components, venting components, etc.) could result in a safety hazard and will void the warranty and certification.
- Ensure that the fan's power cord is not in contact with any surface of the appliance to prevent electrical shock or fire damage. Do not run the power cord beneath the appliance.
- The wire harness provided in the blower kit is a universal harness. When installed, ensure that any excess wire is contained, prevent it from making contact with moving or hot objects.

Drywall dust will penetrate into the blower bearings, causing irreparable damage. Care must be taken to prevent drywall dust from coming into contact with the blower or its compartment. Any damage resulting from this condition is not covered by the warranty policy. Use of the blower increases the output of heat.

Provisions have been made on this appliance to install an optional blower kit (NEP70) that comes complete with a variable speed switch to turn the blower ON/OFF, as well as to adjust the blower speed.

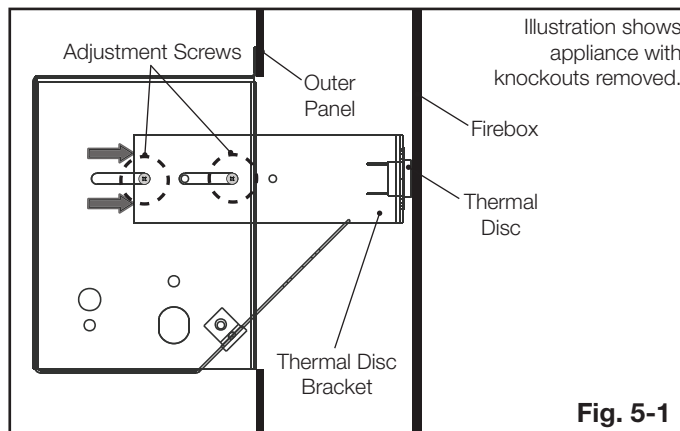

Fig. 5-1

1. Ensure the thermal disc bracket is in the correct position (**Fig. 5-1**).
2. Remove the two knockouts from the back of the appliance.
3. Install the blower and housing as shown (**Fig. 5-2**) using 4 screws (supplied).
4. Loosen the adjustment screws.
5. Reach between the outer panel and the firebox, then slide the thermal disc bracket until the thermal disc is touching the rear of the firebox (**Fig. 5-1**).

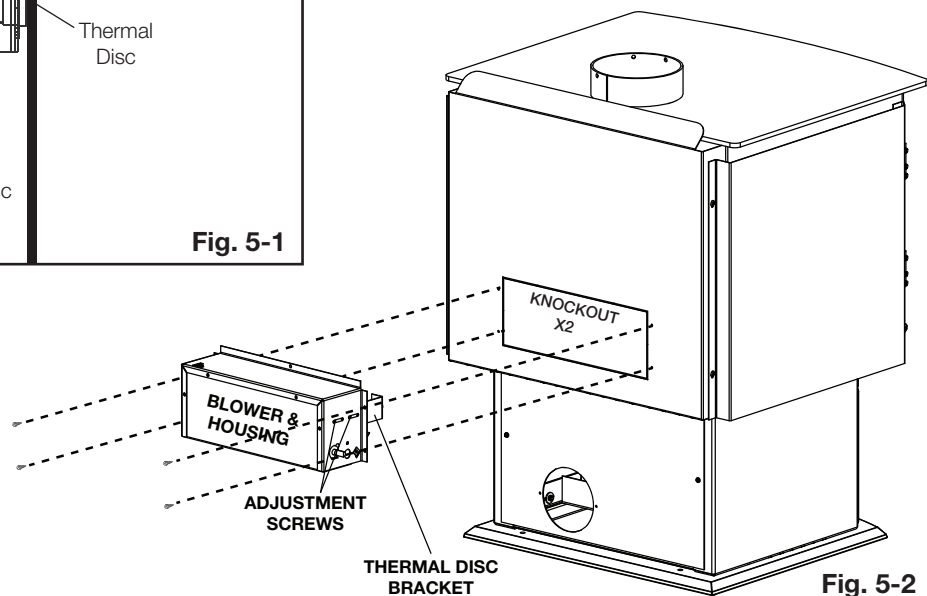

Fig. 5-2

note:

For optimal performance, the thermal disc **MUST** make contact with the firebox.

6. Re-secure the adjustment screws to hold the thermal disc bracket in place.

5.2 ash disposal kit (ADS20)

! WARNING

- Failure to achieve a good seal between the ash opening and ash plug will result in an over-fire condition that could cause damage to the appliance.

Provisions have been made on the appliance to install an optional ash disposal kit. The kit allows for convenient removal of excess ash.

note:

If the appliance has been previously operated, it must be cold and the ashes must be removed in order to access the ash plug.

1. Open the ash disposal.
2. From the underside of the appliance, remove the nuts that secure the ash opening cover plate (**Fig. 5-3**). Discard cover plate and nuts.
3. Place the ash disposal housing into the ash disposal. Ensure the dimples fit into the bosses (**Fig. 5-4**). Close the ash disposal.
4. Remove the small light weight brick that covers the ash opening and set aside for future use (**Fig. 5-5**).

note:

It is important that the area around the ash opening be cleaned well to ensure that a proper seal is created between the new ash plug and the ash opening.

5. Once the area surrounding the opening has been cleaned, place the new ash plug (supplied) over the opening. Ensure the protrusion on the ash plug is recessed into the opening on the bottom of the firebox (**Fig. 5-6**).

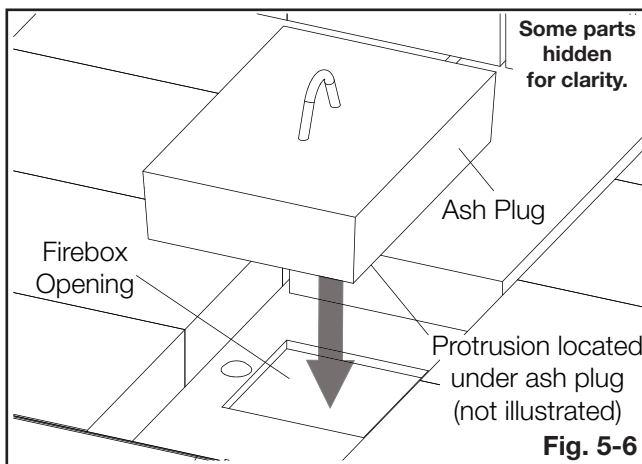
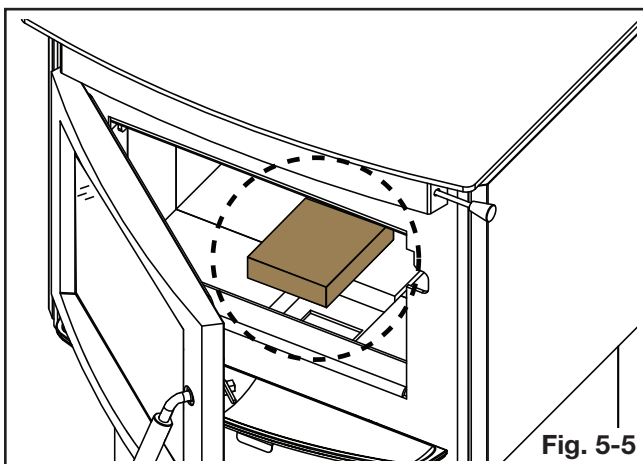
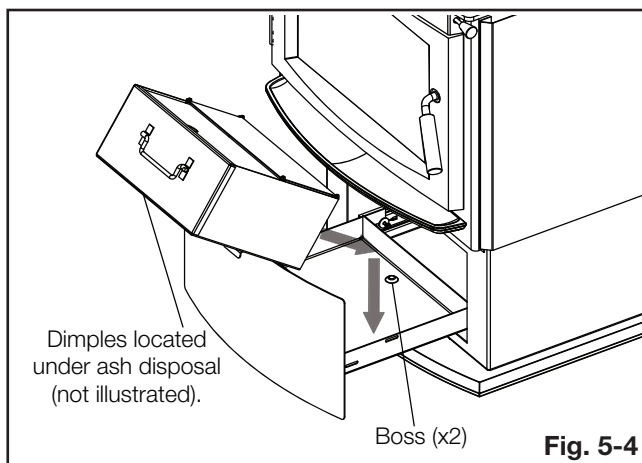
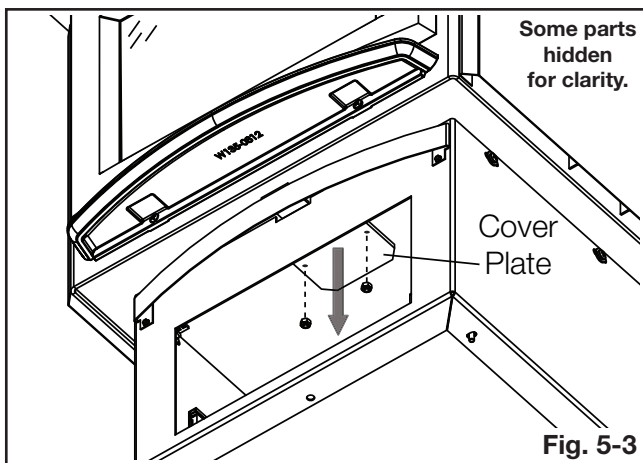

6.0 operation

WARNING

- Always operate this appliance with the door closed and latched except during startup and re-fueling. Always wear gloves to prevent injury. Do not leave the fire unattended when the door is unlatched as unstable wood could fall out of the fire chamber creating a fire hazard to your home.
- Never leave your children unattended when there is a fire burning in the appliance.
- Never use gasoline, gasoline-type lantern fuel, kerosene, charcoal lighter fluid, or similar liquids to start or 'freshen up' a fire in this appliance. Keep all such liquids well away from the appliance while it is in use.
- Objects placed in front of the appliance should be kept a minimum of 48" (121.9cm) from the front face.
- Any modification of the appliance that has not been approved in writing by the testing authority is considered breaching CSA B365 (Canada) and ANSI/NFPA 211 (USA).
- Open air control (and damper when fitted) before opening firing door.
- Hot while in operation. Keep children, clothing and furniture away. Contact may cause skin burns. Wear gloves to operate your appliance.
- Burning your appliance with the doors open or ajar creates a fire hazard that may result in a house and/or chimney fire.
- This wood appliance has a manufacturer-set minimum low burn rate that must not be altered. It is against federal regulations in the United States to alter this setting or otherwise operate this wood appliance in a manner inconsistent with operating instructions in this manual.

Your Napoleon EPA listed product is a Hi-tech appliance, designed with the most advanced technology. The appliance is extremely airtight.

The first fire(s) in your appliance will be difficult to get going and keep going with little amount of heat being generated. This is a result of the moisture being driven out of the fire brick. During the break-in period (the first 2 or 3 fires) create only small, fires using kindling; this will allow the firebrick to cure. Do not be alarmed if small hairline cracks develop in the firebrick. This is a normal occurrence and does not pose a safety hazard. The paint may also smell a little for the first few fires as it cures and you may wish to open a door or window to alleviate the smell.

To start, a brisk fire is required. Place loosely crumpled paper on the floor of the appliance and cover with dry kindling. Open the air control fully by sliding control all the way to the right. Light the paper and leave the door slightly ajar (1"/25.4mm) until all kindling is burning. To maintain a brisk fire, a hot coal bed must be established and sustained.

Slowly add larger wood (2x4 size pieces). Lay the pieces lengthwise from side to side in the hot coal bed with a shallow trench between, so that the primary air can flow directly into this trench and ignite the fuel above. When the fire seems to be at its peak, medium sized logs may be added. Once these logs have caught fire, carefully close the door. (Closing the door too quickly after refueling will reduce the firebox temperature and result in an unsatisfactory burn.) Remember it is more efficient to burn medium sized wood, briskly, and refuel frequently than to load the appliance with large logs that result in a smoldering, inefficient fire and dirty glass.

As soon as the door is closed, you will observe a change in the flame pattern. The flames will get smaller and lazier because less oxygen is getting into the combustion chamber. The flames, however, are more efficient. The flames will remain lazy but become larger again as soon as the firebricks have been heated thoroughly and the chimney becomes heated and provides a good draft. At this point, the roaring fire that you see when the door is opened is wastefully drawing heated room air up the chimney, certainly not desirable. Always operate with the door fully closed once the medium sized logs have caught fire.

You can now add larger pieces of wood and operate the appliance normally. Once the appliance is entirely hot, it will burn very efficiently with little smoke from the chimney. There will be a bed of orange coals in the firebox and secondary flames flickering just below the top baffles. You can safely fill the firebox with wood to the top of the door and will get best burns if you keep the appliance pipe temperatures between 250°F (120°C) and 450°F (270°C). A surface thermometer will help regulate this.

Without an appliance thermometer, you are working blindly and have no idea of how the appliance is operating! An appliance thermometer offers a guide to performance and should be located 18" (457mm) above the flue collar. Install the thermometer according to manufacturers instructions.

Can't get the fire going?

Use more kindling and paper. Assuming the chimney and vent are sized correctly and there is sufficient combustion air, the lack of sufficiently dry quantities of small kindling is the problem. Thumb size is a good gauge for small kindling diameter.

Can't get heat out of the appliance?

One of two things may have happened. The appliance door may have been closed prematurely and the appliance itself has not reached optimum temperature. Re-open the door and/or draft control to re-establish a brisk fire. The other problem may have been wet wood. The typical symptom is sizzling wood and moisture being driven from the wood.

6.1 optimum burn method

For optimal emissions performance and efficiency follow these simple guidelines when using your appliance:

- A.** Maintain a 2" (51mm) deep, hot, glowing red coal bed.
- B.** Burn dry seasoned wood with less than 20% moisture content and burn so that the glass door remains clean.
- C.** A stove thermometer 18" (457mm) up on the single wall stove pipe should indicate 350°F (176°C) as an average temperature.
- D.** Maintain a minimal trace of smoke coming from the chimney when the appliance is burning as intended.
- E.** Inspect and replace all necessary components such as gaskets, manifolds, glass and other components which may affect the overall appliance performance.
- F.** Ensure an adequate draft to control burn rate and temperature.

Refer to "operation" and "maintenance" sections for detailed information.

6.2 optional blower operation

The following operating procedure is recommended to achieve optimal performance:

When operating on high burn rate:

1. We recommend setting the blower to the "HIGH" setting and operating with a thermodisc (located at the back of the appliance).

When operating on medium burn rate:

2. We do not recommend using the blower.

When operating on low burn rate:

3. We recommend turning on the blower after approximately 60 minutes at the minimum setting and operating with a thermodisc (located at the back of the appliance).

6.3 air control

! WARNING

- This wood appliance has a manufacturer-set minimum low burn rate that must not be altered. It is against federal regulations in the United States to alter the setting or otherwise operate this wood appliance in a manner inconsistent with operating instructions in this manual.

Draft is the force which moves air from the firebox up through the chimney. The amount of draft in your chimney depends on the length and diameter of chimney, local geography, nearby obstructions and other factors including the amount of heat generated by the fire which can be measured by an appliance thermometer.

Before adjusting the air control, install the knob (supplied) by screwing it onto the end of the air control rod (**Fig. 6-1**).

Adjusting the air control all the way to the left reduces the temperature. The draft can be adjusted from low to high by moving the handle in and out (**Fig. 6-2**).

Inadequate draft may cause back-puffing into the room through the appliance and chimney connector points and may cause plugging of the chimney. Too much draft may cause an excessive temperature in the appliance, glowing red appliance parts or chimney connectors or an uncontrollable burn which can lead to a chimney fire or permanent damage to the appliance.

Do not operate your appliance for longer than 30 minutes with the draft control on "HIGH" (fully open).

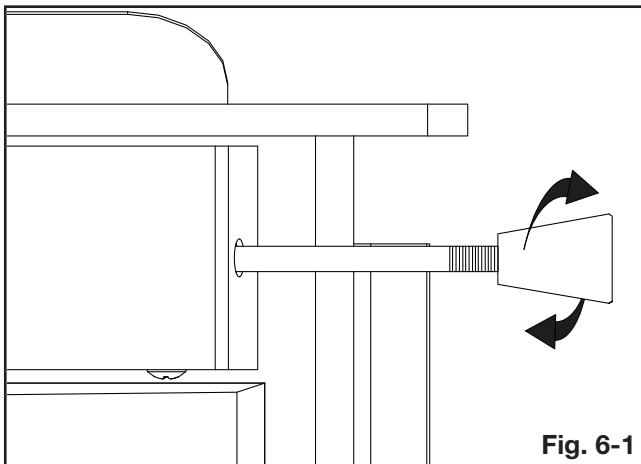

Fig. 6-1

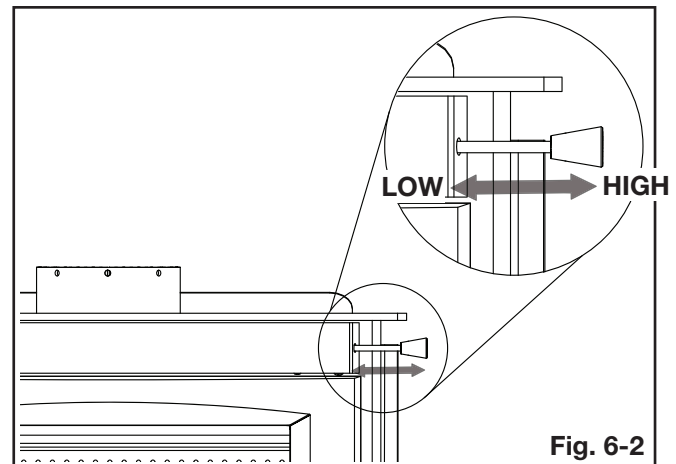

Fig. 6-2

6.4 fire extinguishers / smoke & carbon monoxide detectors

note:

Always check your smoke and CO detectors are working properly.

All homes with a solid fuel burning appliance should have at least one fire extinguisher in a central location, known to all, at least one smoke detector and carbon monoxide (CO) detector in the room containing the appliance. If the smoke detector sounds an alarm, correct the cause but do not deactivate or relocate the smoke detector. If the carbon monoxide detector sounds an alarm, immediately vent the area, evacuate and call your local fire department.

6.5 fuel

! WARNING

- Do not store fuel within the clearance to combustibles, or in the space required for re-fueling and ash removal.
- Burning wet, unseasoned wood can cause excessive creosote accumulation. When ignited, it can cause a chimney fire that may result in a serious house fire.

When loading the appliance, ensure that the two upper fibre baffles are not lifted up and off the ledge. For maximum efficiency, when the appliance is thoroughly hot, load it fully to the top of the door opening and burn at a medium low setting. Maximum heat for minimum fuel (optimum burn) occurs when the appliance top temperature is between 500°F (260°C) and 600°F (315°C). The bricks will be nearly all white and the glass mostly clear. The whiteness of the bricks and the cleanliness of the glass are good indicators of your operating efficiency. Not enough heat is produced when only one or two pieces of wood are burned or the wood may not burn completely. A minimum of three pieces are needed to encase a bed of coals that sustains the fire.

note:

When loading the appliance, ensure to keep fuel back from the glass. If coals are to accumulate on the front lip, there is a chance they will fall out when the door is opened.

Loosely stacked wood burns quicker than a tightly packed load. Wood burns in cycles rather than giving a steady output of heat. It is best to plan these cycles around your household routine so that only enough coals are left to start the next load. In the evening, load your appliance, at least, a half-hour before bed to ensure a good fire, hot enough to close the draft control for an overnight burn.

Burn only dry seasoned wood with less than 20% moisture content. It produces more heat and less soot or creosote. Do not burn ocean beach wood. Its salt content can produce a metal-eating acid. When refueling open the door slowly to prevent smoke spillage. Use a pair of long gloves (barbecue gloves) when feeding the fire. Because these appliances burn at the front, they are clean and efficient, but they are also very hot and gloves are useful. Keep a small steel shovel nearby to use as a poker and to remove ashes. Do not store the wood within 3 feet (1m) of the appliance.

6.6 lighting a fire

6.6.1 flash fire

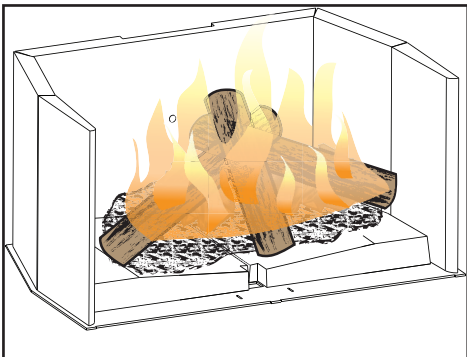

A flash fire is a small fire burned quickly when you don't need much heat. After your kindling has "caught", load at least 3 pieces of wood, stacked loosely. Burn with the draft control fully open or closed only slightly.

operation

6.6.2 extended fire

Load your larger pieces of wood so they are tightly packed, close enough to prevent the flames from penetrating it completely. After approximately 30 minutes, depending on the size of the load, close the draft control completely making sure that the fire is not extinguished.

DO NOT OVERFIRE THE APPLIANCE!

Overfiring can occur by:

- A.** Burning large amounts of smaller wood pieces such as furniture scraps, skids or treated wood;
- B.** Vigorously burning large loads of wood with the draft control on "HIGH" (fully open) for long periods of time (one or two hours).
- C.** Operating the appliance with the ash dump door blocked open or a poor gasket seal on the main door.

6.7 smoking

A properly installed appliance should not smoke. If yours does, check the following:

- Has the chimney had time to get hot?
- Is the smoke passage blocked anywhere in the appliance, chimney connector or chimney?
- Is the room too airtight and the air intake not connected to the outside? Try with a window partly open.
- Is the smoke flow impeded by too long a horizontal pipe or too many bends?
- Is it a weak draft perhaps caused by a leaky chimney, a cold outside chimney, too large a diameter of a chimney, too short a chimney, or a chimney too close to trees or a higher roof?
- Is the moisture content of the wood greater than 20%?
- If equipped, has the catalyst bypass been closed or closed prematurely?

! WARNING

- Turn off the power before servicing the appliance.
- Appliance may be hot, do not service until appliance has cooled.
- Do not use abrasive cleaners.

Check your chimney and chimney connector for creosote and soot buildup weekly until a safe frequency for cleaning is established. If accumulation is excessive, disconnect the appliance and clean both the chimney and the appliance. You may want to call a professional chimney sweep to clean them. Both have to be cleaned at least once a year or as often as necessary.

Remove fibre baffles and clean above them once a year. Replace any broken bricks or baffles.

7.1 ash removal procedures**! WARNING**

- Improper disposal of ashes result in fires. Do not discard ashes in cardboard boxes, dump in backyards, or store in garages.
- If using a vacuum to clean up ashes, be sure the ashes are entirely cooled. Using a vacuum to clean up warm ashes could cause a fire inside the vacuum.
- Never operate your appliance with the grate cover removed.
- Failure to achieve a good seal between the ash opening, ash plug or ash well door will result in an over-fire condition that could cause damage to the appliance.

Allow the ashes in your firebox to accumulate to a depth of two or three inches; they tend to burn themselves up. When the fire has burned down and cooled, remove any excess ashes but leave an ash bed approximately 1 inch (25mm) deep on the firebox bottom to help maintain a hot charcoal bed.

DISPOSAL OF ASHES: Ashes should be placed in a metal container with a tight fitting lid. The closed container of ashes should be placed on a non-combustible floor or ground, well away from all combustible materials, pending final disposal. If the ashes are disposed of by burial in soil or otherwise locally dispersed, they should be retained in the closed container until all cinders have thoroughly cooled.

7.1.1 ash removal with ash disposal kit

- To remove the ashes, clear the ash away from the ash plug.
- Remove the ash plug. **It is recommended to use a poker.**
- Rake the excess ash into the ash disposal.
- **Do not overfill the ash disposal. Ash should not accumulate higher than the sides of the drawer.**
- Before removing the drawer, ensure that the area around the ash opening is clean. Tap the ash from the chute into the drawer, then place the ash plug back over opening. Only operate your appliance with a well sealed ash plug.

maintenance

7.2 creosote formation and removal

When wood is burned slowly, it produces tar and other organic vapors, which combine with expelled moisture to form creosote. The creosote vapors condense in the relatively cooler chimney flue or a slow-burning fire. As a result, creosote residue accumulates on the flue lining. When ignited, this creosote makes an extremely hot fire.

The chimney connector and chimney should be inspected at least once every two months during the heating season to determine if a creosote buildup has occurred.

If creosote has accumulated, it should be removed to reduce the risk of a chimney fire.

7.3 runaway or chimney fire

WARNING

- A chimney fire can permanently damage your chimney system. This damage can only be repaired by replacing the damaged component parts. Chimney fires are not covered by the lifetime limited warranty.

CAUSES:

- Using incorrect fuel, or small fuel pieces which would normally be used as kindling.
- Creosote build up in chimney.
- Leaving the door ajar too long and creating extreme temperatures as the air rushes in the open door.
- If equipped, burning your appliance with the ash plug not securely seated.

SOLUTIONS:

- Do not burn treated, painted, artificial, paper or processed wood logs, coal, charcoal, coloured paper or cardboard.
- Have chimney regularly cleaned.
- Be careful not to over-fire the appliance by leaving the door open too long after initial start-up. A thermometer on the chimney connector and/or appliance top helps to indicate the appliance operating temperature.
- If equipped, always operate the appliance with the ash plug properly installed.

IN CASE OF A CHIMNEY FIRE:

- Close glass door and air control (and damper, when equipped).
- Have a well understood plan for evacuation and a place outside for everyone to meet. Prepare to evacuate to ensure everyone's safety.
- Call local fire department. Have a fire extinguisher handy. Contact local authorities for further information on how to handle a chimney fire.
- After the chimney fire is out, clean and inspect the chimney or chimney liner for stress and cracks prior to lighting another fire. Also check combustibles around the chimney and the roof.

7.4 chimney cleaning

Both the chimney and the appliance must be inspected and cleaned if necessary at least once a year.

For serious wood burners, chimney cleaning must be done as needed to avoid chimney fires; the venting systems for controlled combustion appliances may need cleaning as often as once a month. These rates, however, depend on the burning habits of the individual operating the appliance. For example, it is possible to clog a solid fuel appliance chimney in a few days if slow, smoldering fires are burned and the chimney is cold.

note:

Appliances burned consistently without hot fires may result in significant creosote accumulations in the chimney.

Certain items and considerations are important in chimney cleaning:

- Proper tools should be used, including a brush specifically designed for chimney cleaning.
- The chimney connector and dampers as well as the chimney should be cleaned.
- The appliance's firebox and baffle system should be cleaned if needed.
- The chimney should be inspected and repairs made if needed, preferably by a qualified chimney sweep or mason.

7.5 door glass replacement

! WARNING

- Do not use substitute materials.
- Glass may be hot. Do not touch glass until cooled.
- Care must be taken when removing and disposing of any broken door glass or damaged components. Be sure to vacuum up any broken glass from inside appliance before operation.
- Do not strike, slam, or scratch. Do not operate appliance with glass removed, cracked, broken, or scratched.

1. When the appliance is cool, have two people remove the door and place it face down on a soft, non-abrasive surface (see “door removal” section). Be careful not to scratch the paint.
2. Remove the 6 screws securing the glass retainers (**Fig. 7-1**). Set the screws and glass retainers aside.
3. Remove all broken glass and the old gasket.
4. Apply **high temperature silicone** (not supplied) in the gasket groove as illustrated (**Fig. 7-2**).
5. Cut the 1/4” gasket (supplied) to size and place on top of the silicone. Press the gasket down firmly to ensure it stays in place. Ensure the gasket joint is at the bottom as illustrated (**Fig. 7-2**).
6. Place new glass on top of the gasket.
7. Re-secure the 6 glass retainers by installing the 6 screws previously removed in step 2 (**Fig. 7-3**). Ensure the retainer dimples face away from the glass.
8. Re-install the door.

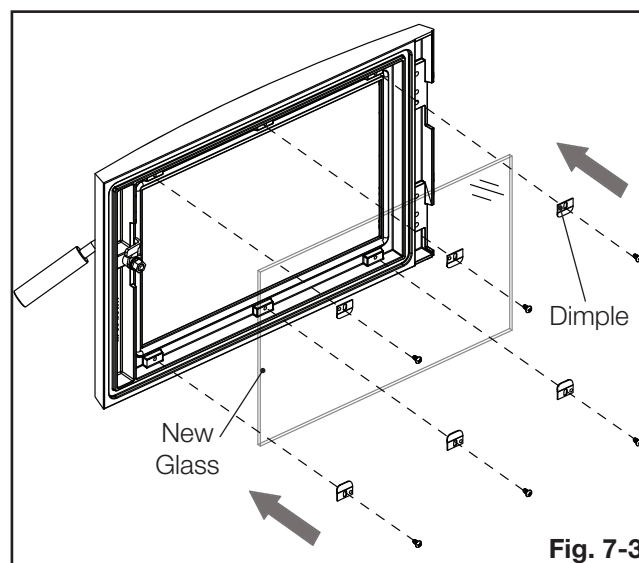
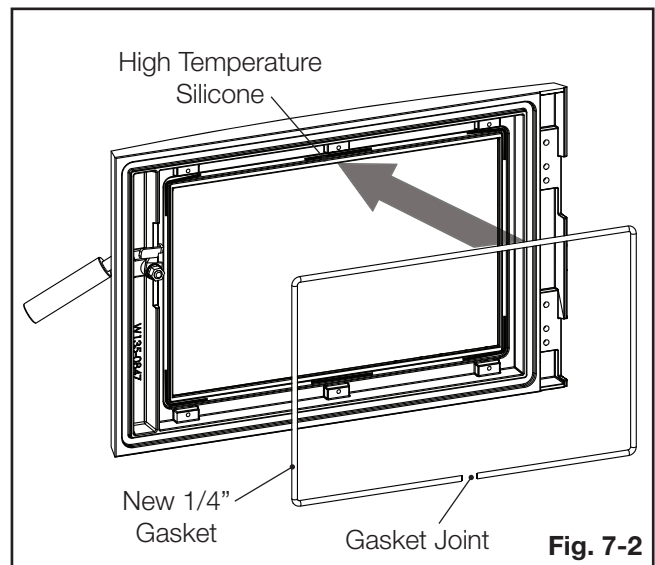
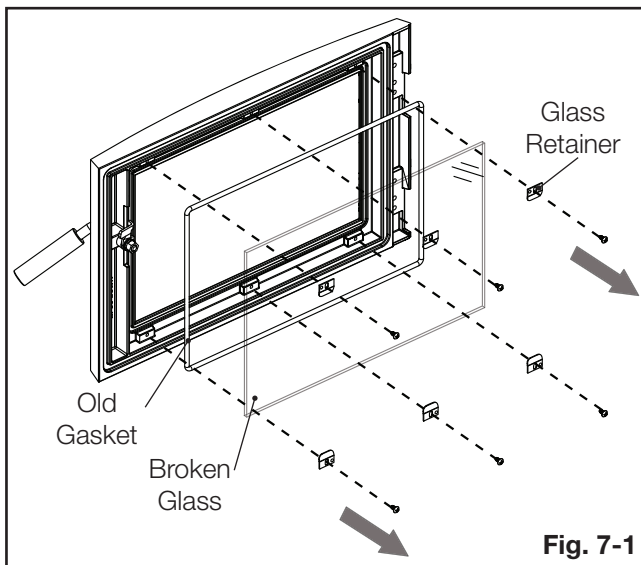

7.6 care of glass

! WARNING

- Do not clean glass when hot! Do not use abrasive cleaners to clean glass.

If the glass is not kept clean, permanent discolouration and/or blemishes may result. Normally a hot fire will clean the glass. The most common reasons for dirty glass include:

- Not using sufficient fuel to get the appliance thoroughly hot.
- Using green or wet wood.
- Closing the draft so far that there is insufficient air for complete combustion.

If it is necessary to clean the glass, buff lightly with a clean dry cloth and non-abrasive cleaner. Clean the glass after the first 10 hours of operation with a recommended appliance glass cleaner. Thereafter, clean as required.

The glass is very strong, but do not let burning fuel rest or fall against it and always close the door gently.

NEVER FORCE OR SLAM IT SHUT!

Do not operate the appliance with broken glass, as leakage of flue gases may result.

Contact your local authorized dealer/distributor for complete cleaning instructions.

If the glass should ever crack or break while the fire is burning, do not open the door until the fire is out. Do not operate the appliance until the glass has been replaced. Contact your local authorized dealer/distributor for replacement parts. **DO NOT SUBSTITUTE MATERIALS.**



7.7 door gasket replacement

- When the appliance is cool, remove the door and place it face down on a soft, non-abrasive surface (see "door removal" section). Be careful not to scratch the paint.
- Apply **high temperature silicone** (not supplied) in the gasket groove as illustrated (**Fig. 7-4**).
- Cut the 1/2" gasket (supplied) to size and place on top of the silicone. Press the gasket down firmly to ensure it stays in place. Ensure the gasket joint is at the bottom as illustrated (**Fig. 7-4**).
- Re-install the door.

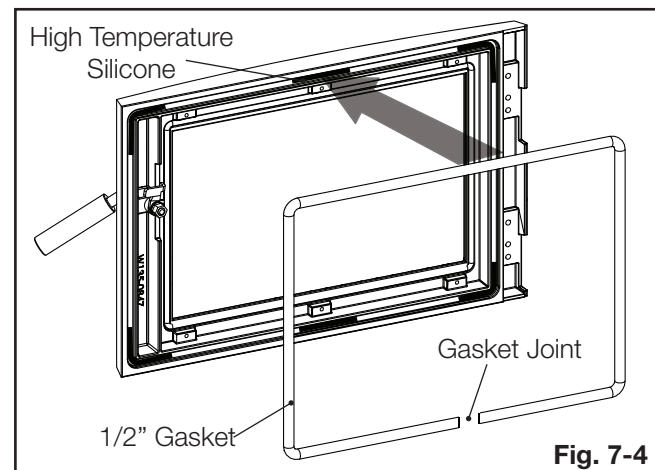

Fig. 7-4

7.8 wood

! WARNING

- This appliance is designed to burn natural wood only. Do not burn treated wood, coal, charcoal, coloured paper, cardboard, solvents or garbage. This appliance has not been tested with an unvented gas log set. To reduce risk of fire or injury, do not install an unvented gas log set into the appliance.
- Higher efficiencies and lower emissions generally result when burning air dried seasoned hardwoods, as compared to softwoods or too green or freshly cut hardwoods.
- Burning wet unseasoned wood can cause excessive creosote accumulation. When ignited, it can cause a chimney fire that may result in a serious house fire.
- Do not store fuel within the clearance to combustibles, or in the space required for re-fueling and ash removal.

Before loading the appliance, ensure all required insulation and baffles (if equipped) are installed and situated properly. For maximum efficiency, when the appliance is thoroughly hot, load it fully to the specified maximum amount and burn at a medium low setting (if equipped). The whiteness of the bricks and the cleanliness of the glass are good indicators of your operating efficiency. Not enough heat is produced when only a few pieces of wood are burned or the wood may not burn completely.

note:

Appliances surrounded by solid rock or brick will experience a longer heat up period as those materials absorb the heat being generated.

TYPES OF WOOD

Both hardwood and softwood burn equally well in this appliance but hardwood is denser, will weigh more per cord and burn a little slower and longer.

Manufactured firelogs made by compressing 100% natural wood fibre can be safely used as fuel. Do not use manufactured firelogs if they contain additives such as paraffin, wax, binders etc. Never burn more than two manufactured firelogs at a time.

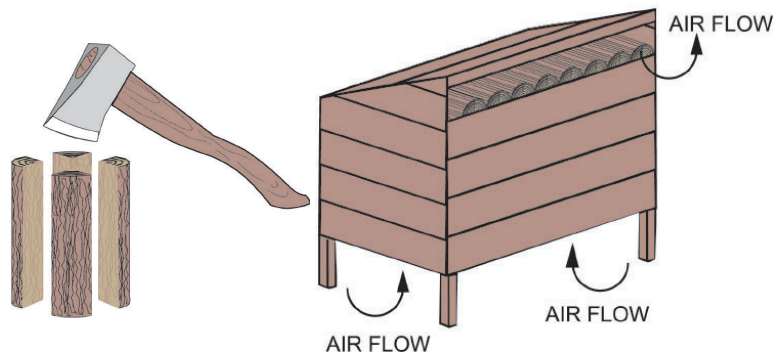

MOISTURE CONTENT

Burn only dry, clean unpainted wood that has been seasoned. It produces more heat and less soot or creosote. Freshly cut wood contains about 50% moisture while after proper seasoning only about 20% of the water remains. As wood is burned, this water boils off consuming energy that should be used in heating. The wetter the wood, the less heat is given off and the more creosote is produced. Dry firewood has cracks in the end of the grain.

STORING WOOD

Firewood should be split and stacked in a manner that allows for full air circulation and covered in early spring to be ready for burning that fall. Dry firewood has cracks in the end grain.

Cut the wood so that it will fit horizontally, front to back, making for easier loading and less of a likelihood that the wood will roll onto the glass.

Fuel for the appliance must not be stored closer than the required clearances to combustibles (heat sensitive material). **NEVER STORE WOOD IN THE ASH PAN COMPARTMENT (if applicable).**

8.0 replacement parts

WARNING

- Failure to position the parts in accordance with this manual or failure to use only parts specifically approved with this appliance may result in property damage or personal injury.

Contact your dealer for questions concerning prices and policies on replacement parts. Normally, all parts can be ordered through your Authorized dealer / distributor.

For warranty replacement parts, a photocopy of the original invoice will be required to honour the claim.

When ordering replacement parts always give the following information:

- Model & Serial Number of appliance
- Installation date of appliance
- Part number
- Description of part
- Finish

Parts, part numbers, and availability are subject to change without notice.

Parts identified as stocked will be delivered within 2 to 5 business days for most delivery destinations.

Parts not identified as stocked will be delivered within a 2 to 4 week period, for most cases.

Parts identified as 'SO' are special order and can take up to 90 days for delivery.

8.1 overview part 1

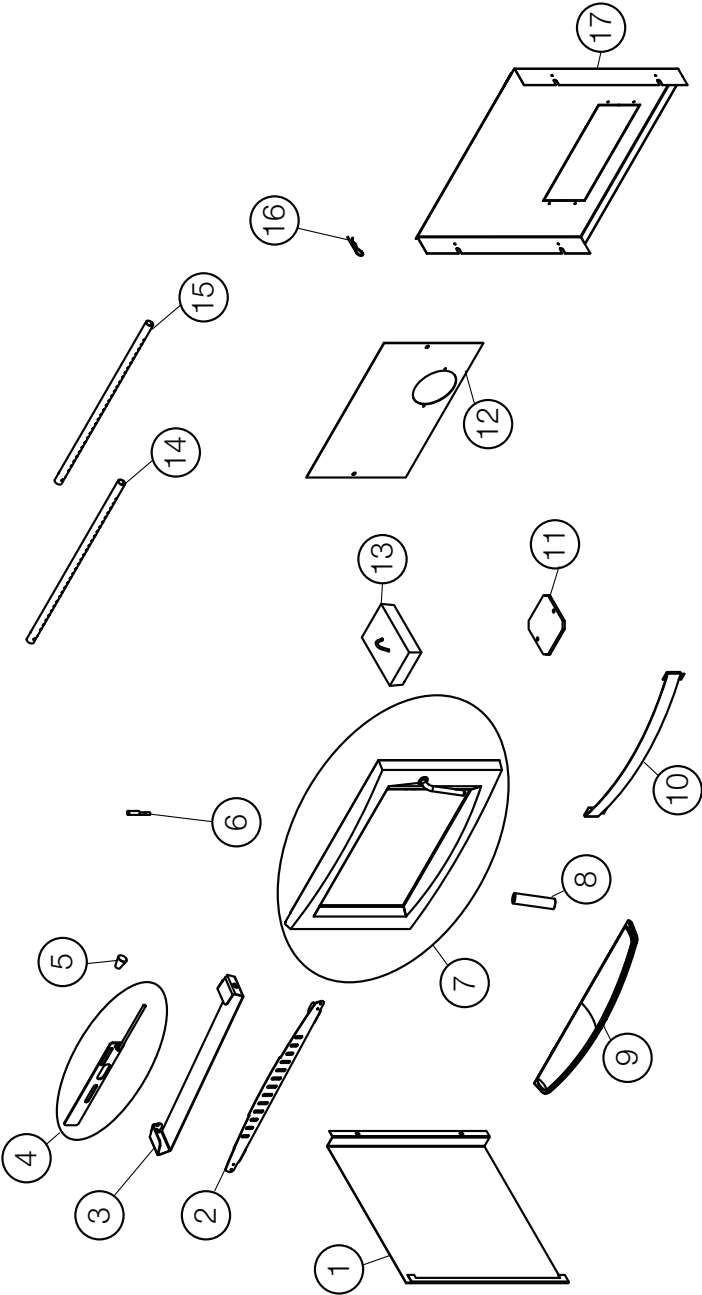

Items may not appear exactly as illustrated.

Ref. No.	Part Number	Description	Stocked
1	W585-0947	Shield, heat sides	
2	W200-0785	Cover, primary air, lower	
3	W200-0784	Cover, primary air	
4	W010-4589	Assembly, air control	
5	W380-0034	Knob, primary air control	
6	W485-0053	Spring, adjustable cam hinge	Yes
7	W010-4550	Assembly, door and glass	
8	W325-0103	Handle, front door	
9	W135-0812	Casting, ash lip	
10	W200-0783	Cover, ash drawer top	

Ref. No.	Part Number	Description	Stocked
11	W510-0022	Inner cover plate	
12	W500-1030	Plate, back pedestal	
13	W510-0011	Plug, ash brick	
14	W720-0189	Tube, front secondary air	
15	W720-0190	Tube, secondary air (x3)	
16	W485-0047	Pin, hairpin cotter	Yes
17	W585-0948	Shield, rear heat	

8.2 overview part 2

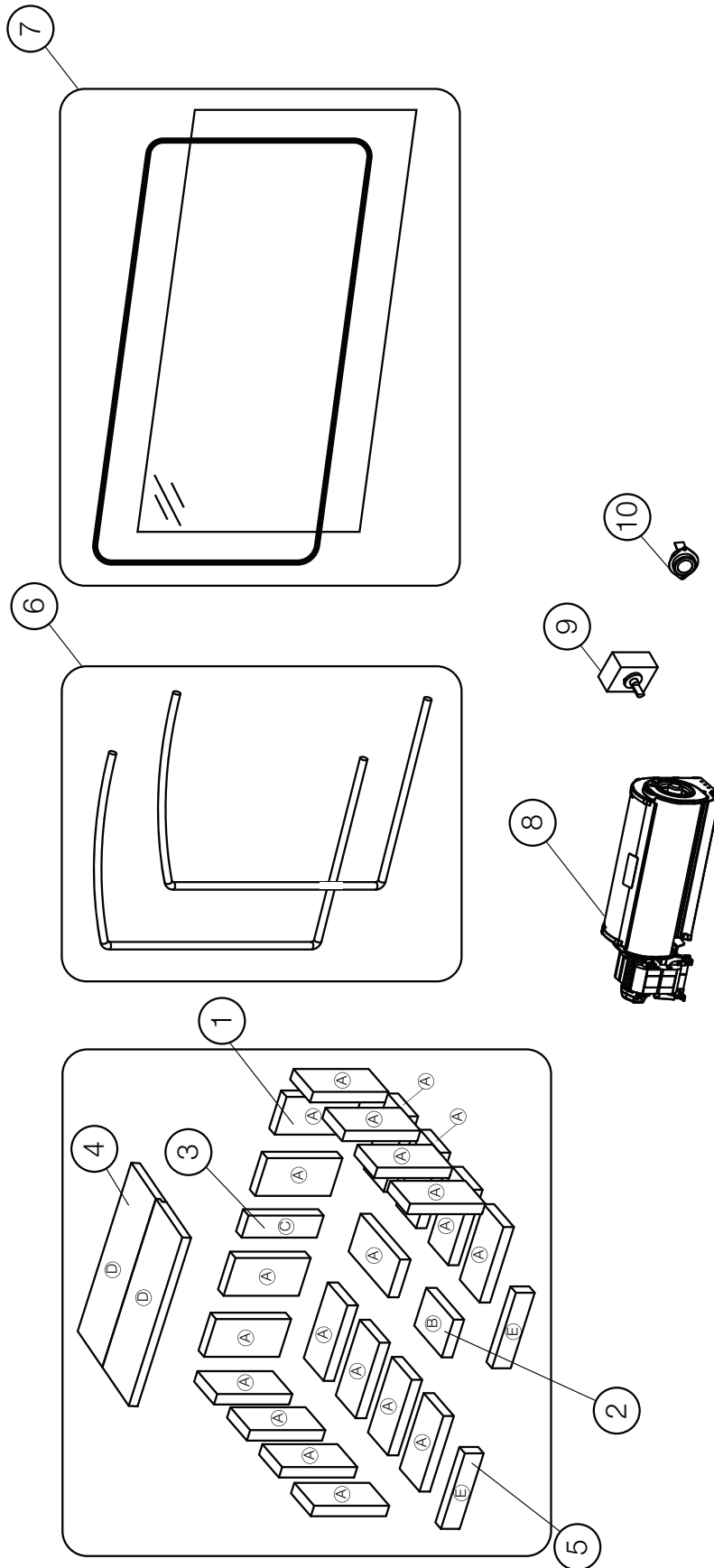

Items may not appear exactly as illustrated.

Ref. No.	Part Number	Description	Stocked
1	W090-0338	Brick, 1.250 x 4.500 x 9.000 (A)	
2	W090-0340	Brick, 1.250 x 6.250 x 4.500 (B)	
3	W090-0341	Brick, 1.250 x 2.625 x 9.000 (C)	
4	W010-3564	Baffles, ceramic fiber (D)	Yes
5	W090-0339	Brick, 2.250 x 9.000 x 1.250 (E)	
6	W562-0002-SER	Kit, door gasket	Yes
7	W300-0168-SER	Kit, glass and gasket	Yes
8	GZ552	Blower, replacement	Yes
9	KB-35	Variable speed switch	Yes
10	W690-0002	Thermodisc (heat sensor)	Yes

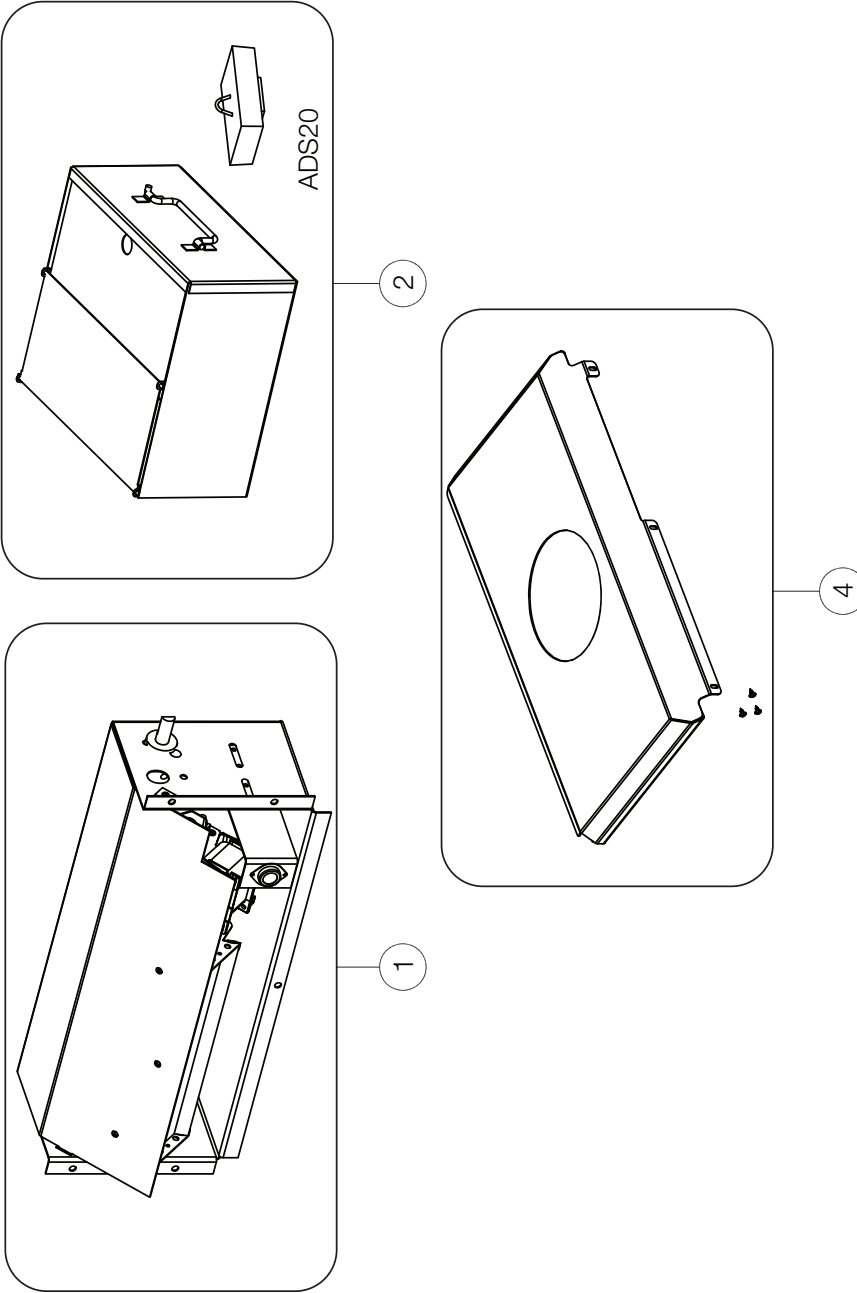

Items may not appear exactly as illustrated.

Ref. No.	Part Number	Description	Stocked
1	NEP70	Blower kit	
2	ADS20	Kit, ash disposal	
3 *	111KT	Outside air kit	
4	RCHS20	Low clearance combustion kit	

* Parts not illustrated.

10.0 troubleshooting

WARNING

- Turn off the appliance completely and let cool before servicing. Only a qualified service person should service and repair this electric appliance.
- Appliance may be hot, do not service until appliance has cooled.
- Do not use abrasive cleaners.
- When checking connections, installing jumper wires (for test purposes only) or replacing components, unplug appliance from the receptacle to prevent electrical shock or damage to the component.

symptom	test solution
Can't get the fire started.	Not enough kindling / paper? Add more.
	Not enough air? Ensure air control is fully open. Also ensure that the air opening is not obstructed.
	Cold air blockage? Burn a piece of paper to establish a draft.
	Use dry seasoned wood with 20% moisture content.
Smokes when door is open.	Flue blockage? Inspect chimney.
	Cold air blockage? Burn a piece of paper to establish a draft.
	Insufficient draft? Add more pipe.
	Let air stabilize before opening door.
Appliance emits odour.	Ensure baffles are positioned correctly.
	Negative pressure? Open a window near the appliance.
Stove doesn't burn hot enough.	Paint curing, see "general instructions" section.
	Wood has more than 20% moisture.
	Insufficient draft? Add more pipe.
Wood burns too fast.	Not enough air? Ensure air control is fully open. Also ensure that the air opening is not obstructed.
	Air control may need to be adjusted down.
	Check to see ash plug is properly seated (if equipped).
	Check door gasket for adequate seal.
Dirty glass.	Wood may be extremely dry.
	Air control may be closed too far.
	Burn hotter, smaller fires.
Blower does not run.	Use well seasoned wood with 20% moisture content.
	Appliance may not be up to temperature.
	Ensure blower has power.

Napoleon Wood Appliances are manufactured under the strict Standard of the world recognized ISO 9001 : 2015 Quality Management System.

Napoleon products are designed with superior components and materials assembled by trained craftsmen who take great pride in their work. The complete appliance is again thoroughly inspected by a qualified technician before packaging to ensure that you, the customer, receives the quality product that you expect from **Napoleon**.

Napoleon Wood Appliances President's Lifetime Limited Warranty

The following materials and workmanship in your new **Napoleon** Wood Appliance are warranted against defects for as long as you own the appliance. For pellet appliances this covers: the pellet hopper, outer shell, ceramic glass (thermal breakage only) and ash drawer.* For wood appliances this covers: combustion chamber, heat exchanger, stainless steel baffle retainer, ceramic glass (thermal breakage only), gold plated parts against tarnishing, porcelainized enameled components, aluminum extrusion trims, vortex baffles, ash drawer and iron castings.*

For pellet appliances, the combustion chamber and heat exchanger are warranted against defects for a period of 5 years.

For wood appliances equipped with a guillotine door/screen system, they are warranted against defects for a period of 5 years.

Electrical (110V) components and wearable parts are covered and **Napoleon** will provide replacement parts free of charge during the first year of the limited warranty. For pellet appliances this covers: blowers, thermal switches and burn pot.* For wood appliances this covers: blowers, thermal switch, switches, wiring, firebrick, secondary air tubes and gasketing.*

Labour related to warranty repair is covered free of charge during the first year, with the exception of the guillotine door/screen system which will be warranted for a period of 3 years. Repair work, however, requires the prior approval of an authorized company official. Labour costs to the account of **Napoleon** are based on a predetermined rate schedule and any repair work must be done through an authorized **Napoleon** dealer.

For appliances that include firebricks and baffles, they should routinely be removed by the operator as part of the regular service and therefore, any warranty replacement of these parts does not qualify for any labour allowances.

* Construction of models vary. Warranty applies only to components included with your specific appliance.

Conditions and Limitations

Napoleon warrants its products against manufacturing defects to the original purchaser only. Registering your warranty is not necessary. Simply provide your proof of purchase along with the model and serial number to make a warranty claim. Provided that the purchase was made through an authorized **Napoleon** dealer, your appliance is subject to the following conditions and limitations:

Warranty coverage begins on the date of original installation. This factory warranty is non-transferable and may not be extended whatsoever by any of our representatives. The wood appliance must be installed by a qualified and authorized installer, service agency or supplier. Installation must be done in accordance with the installation instructions included with the product and all local and national building and fire codes. This limited warranty does not cover damages caused by misuse, lack of maintenance, accident, alterations, abuse or neglect. Operating the appliance on high for extended periods of time, is neglect. Parts installed from other manufacturers will nullify this warranty.

This limited warranty further does not cover any scratches, dents, corrosion or discoloring caused by excessive heat, abrasive and chemical cleaners nor chipping on porcelain enamel parts, nor any venting components used in the installation of the appliance. In the first year only, this warranty extends to the repair or replacement of warranted parts which are defective in material or workmanship provided that the product has been operated in accordance with the operation instructions and under normal conditions. After the first year, with respect to the President's Limited Lifetime Warranty, **Napoleon** may, at its discretion, fully discharge all obligations with respect to this warranty by refunding to the original warranted purchaser the wholesale price of any warranted but defective parts. After the first year, **Napoleon** will not be responsible for installation, labour or any other costs or expenses related to the reinstallation of a warranted part, and such expenses are not covered by this warranty. Notwithstanding any provisions contained in the President's Limited Lifetime Warranty, **Napoleon's** responsibility under this warranty is defined as above and it shall not, in any event, extend to any incidental, consequential or indirect damages. This warranty defines the obligations and liability of **Napoleon** with respect to the **Napoleon** wood appliance and any other warranties expressed or implied with respect to this product, its components or accessories are excluded. **Napoleon** neither assumes, nor authorizes any third party to assume, on its behalf, any other liabilities with respect to the sale of this product. **Napoleon** will not be responsible for: over-firing, downdrafts, spillage caused by environmental conditions such as rooftops, buildings, nearby trees, hills, mountains, inadequate vents or ventilation, excessive venting configurations, insufficient makeup air, or negative air pressures which may or may not be caused by mechanical systems such as exhaust blowers, furnaces, clothes dryers, etc.

Any damages to appliance, combustion chamber, heat exchanger, brass trim or other component due to water, weather damage, long periods of dampness, condensation, damaging chemicals or cleaners will not be the responsibility of **Napoleon**. Regular cleaning of the fine ash generated during the operation of this appliance is a necessary part of maintaining your wood appliance. Failure of any components, which is attributed to poor maintenance, is not warrantable and will not be covered by this policy. **Napoleon** reserves the right to have its representative inspect any product or part thereof prior to honouring any warranty claim. All parts replaced under the President's Limited Lifetime Warranty Policy are subject to a single claim. During the first 10 years **Napoleon** will replace or repair the defective parts covered by the lifetime warranty at our discretion free of charge. From 10 years to life, **Napoleon** will provide replacement parts at 50% of the current retail price. All parts replaced under the warranty will be covered for a period of 90 days from the date of their installation.

The manufacturer may require that defective parts or products be returned or that digital pictures be provided to support the claim. Returned products are to be shipped prepaid to the manufacturer for investigation. If a product is found to be defective, the manufacturer will repair or replace such defect. Before shipping your appliance or defective components, your dealer must obtain an authorization number. Any merchandise shipped without authorization will be refused and returned to sender. Shipping costs are not covered under this warranty. Additional service fees may apply if you are seeking warranty service from a dealer. Warranty labour allowance is only for the replacement of the warranted part. Travel, diagnostic tests, shipping and other related charges are not covered by this warranty and other related charges are not covered by this warranty.

All specifications and designed are subject to change without prior notice due to on-going product improvements. **Napoleon** is a registered trademark of Wolf Steel Ltd.

NAPOLEON CELEBRATING OVER 40 YEARS OF HOME COMFORT PRODUCTS



7200, Route Transcanadienne, Montréal, Québec H4T 1A3
24 Napoleon Road, Barrie, Ontario, Canada L4M 0G8
214 Bayview Drive, Barrie, Ontario, Canada L4N 4Y8
103 Miller Drive, Crittenden, Kentucky, USA 41030

Phone: 1-866-820-8686
napoleon.com