

INSTALLER: LEAVE THIS MANUAL WITH THE APPLIANCE.  
CONSUMER: RETAIN THIS MANUAL FOR FUTURE REFERENCE.  
NEVER LEAVE CHILDREN OR OTHER AT RISK INDIVIDUALS ALONE WITH THE APPLIANCE.



# INSTALLATION AND OPERATING INSTRUCTIONS

CERTIFIED UNDER CANADIAN AND AMERICAN NATIONAL STANDARDS, CR97-003, CAN1-2.21-M85, IAS U.S. 4-96.

## OUTDOOR GAS FIREPLACE GSS36N

CERTIFIED FOR CANADA AND UNITED STATES USING ANSI/CSA METHODS.

### SAFETY INFORMATION

#### **WARNING**

If the information in these instructions are not followed exactly, a fire or explosion may result causing property damage, personal injury or loss of life.

- Do not store or use gasoline or other flammable vapors and liquids in the vicinity of this or any other appliance.
- **WHAT TO DO IF YOU SMELL GAS:**
  - Do not try to light any appliance.
  - Do not touch any electrical switch; do not use any phone in your building.
  - Immediately call your gas supplier from a neighbour's phone. Follow the gas supplier's instructions.
  - If you cannot reach your gas supplier, call the fire department.
- Installation and service must be performed by a qualified installer, service agency or the supplier.

This appliance may be installed in an aftermarket, permanently located, manufactured home (USA only) or mobile home, where not prohibited by local codes.

This appliance is only for use with the type of gas indicated on the rating plate. This appliance is not convertible for use with other gases, unless a certified kit is used.

APPLY SERIAL NUMBER LABEL FROM CARTON



NATURAL GAS MODEL

### GSS36P

PROPANE GAS MODEL

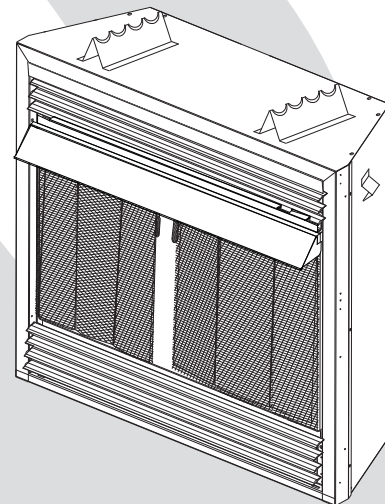

**WARNING: FOR OUTDOOR USE ONLY**

#### **WARNING**



**HOT GLASS WILL CAUSE BURNS.**

**DO NOT TOUCH GLASS UNTIL COOLED.**

**NEVER ALLOW CHILDREN TO TOUCH GLASS.**



Wolf Steel Ltd., 24 Napoleon Rd., Barrie, ON, L4M 0G8 Canada /  
103 Miller Drive, Crittenden, Kentucky, USA, 41030  
Phone (705)721-1212 • Fax (705)722-6031 • [www.napoleonfireplaces.com](http://www.napoleonfireplaces.com) • [ask@napoleonproducts.com](mailto:ask@napoleonproducts.com)

# TABLE OF CONTENTS

<b>1.0</b>	<b>INSTALLATION OVERVIEW</b>	<b>2</b>
<b>2.0</b>	<b>INTRODUCTION</b>	<b>3</b>
2.1	DIMENSIONS	4
2.2	GENERAL INSTRUCTIONS	4
2.3	GENERAL INFORMATION	5
2.4	RATING PLATE INFORMATION	5
<b>3.0</b>	<b>INSTALLATION</b>	<b>6</b>
3.1	GAS INSTALLATION	6
3.2	OPTIONAL WALL SWITCH INSTALLATION	6
3.3	COMBUSTION AND VENTILATION AIR	7
<b>4.0</b>	<b>FRAMING</b>	<b>7</b>
4.1	CLEARANCE TO COMBUSTIBLES	7
4.2	MINIMUM ENCLOSURE CLEARANCES	10
4.3	MINIMUM MANTEL CLEARANCES	11
4.4	NAILING TAB	11
<b>5.0</b>	<b>FINISHING</b>	<b>12</b>
5.1	LOG PLACEMENT	12
5.2	HOOD	13
5.3	LOGO PLACEMENT	13
5.4	LOUVRE INSTALLATION	13
<b>6.0</b>	<b>OPERATION</b>	<b>14</b>
<b>7.0</b>	<b>ADJUSTMENT</b>	<b>15</b>
7.1	VENTURI ADJUSTMENT	15
7.2	FLAME CHARACTERISTICS	15
<b>8.0</b>	<b>MAINTENANCE</b>	<b>16</b>
<b>9.0</b>	<b>REPLACEMENTS</b>	<b>17</b>
<b>10.0</b>	<b>TROUBLESHOOTING</b>	<b>19</b>
<b>11.0</b>	<b>WARRANTY</b>	<b>21</b>
<b>12.0</b>	<b>SERVICE HISTORY</b>	<b>22</b>

## 1.0 INSTALLATION OVERVIEW

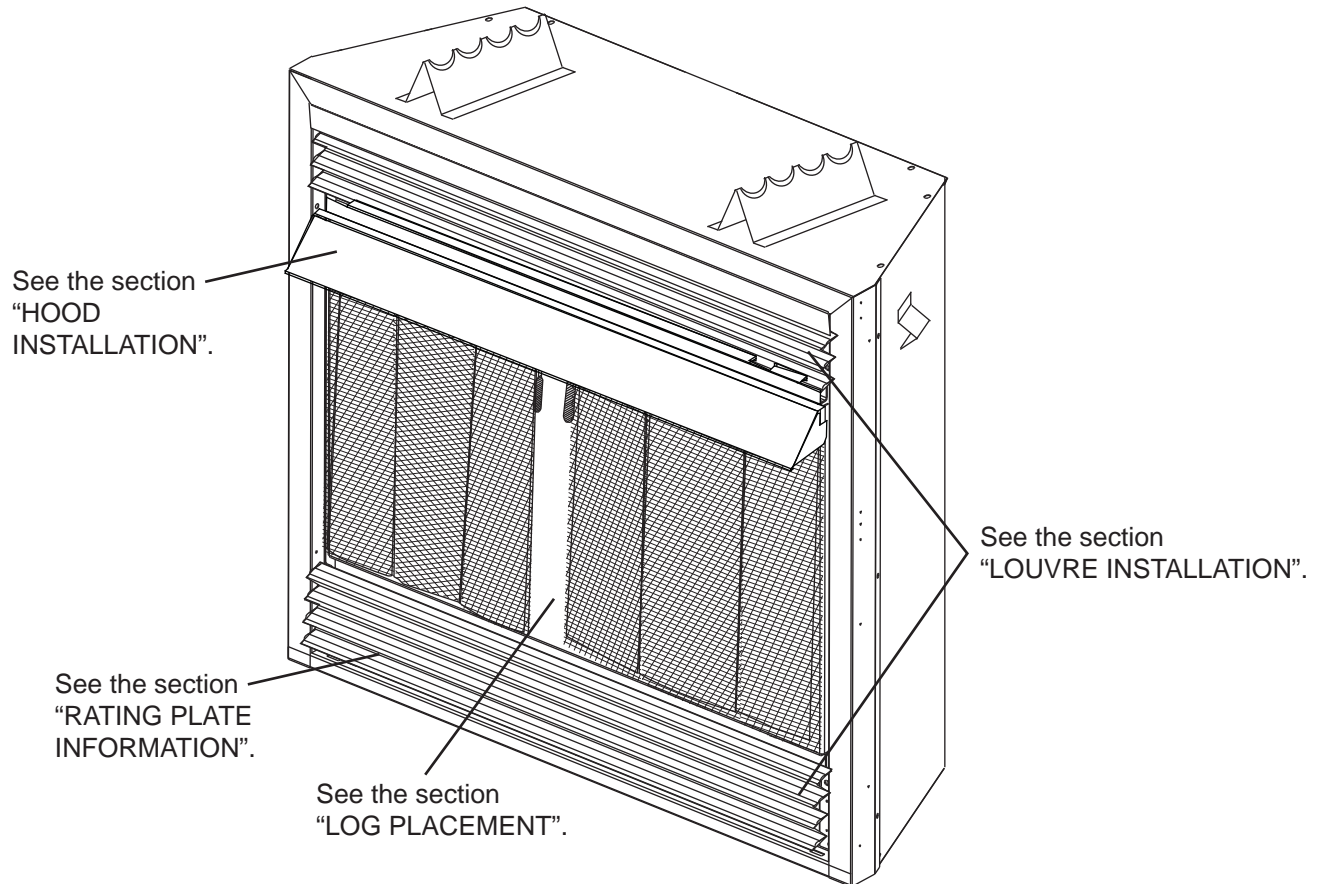

**NOTE:** Changes, other than editorial, are denoted by a vertical line in the margin.

## 2.0 INTRODUCTION

### WARNING

- **THIS APPLIANCE IS HOT WHEN OPERATED AND CAN CAUSE SEVERE BURNS IF CONTACTED.**
- Do not operate appliance before reading and understanding operating instructions. Failure to operate appliance according to operating instructions could cause fire or injury.
- Any changes to this appliance or its controls can be dangerous and is prohibited.
- Risk of burns. The appliance should be turned off and cooled before servicing.
- Do not install damaged, incomplete or substitute components.
- Risk of cuts and abrasions. Wear protective gloves and safety glasses during installation. Sheet metal edges may be sharp.
- Do not burn wood or other materials in this appliance.
- Provide adequate ventilation and combustion air. Provide adequate accessibility clearance for servicing and operating the appliance. Never obstruct the front opening of the appliance.
- If appliance keeps shutting off, have it serviced. Keep burner and control compartment clean.
- Do not allow wind to blow directly into the appliance. Avoid any drafts that alter burner flame patterns.
- Children and adults should be alerted to the hazards of high surface temperature and should stay away to avoid burns or clothing ignition.
- Young children should be carefully supervised when they are in the same area as the appliance. Toddlers, young children and others may be susceptible to accidental contact burns. A physical barrier is recommended if there are at risk individuals in the vicinity of the appliance. To restrict access to an appliance, install an adjustable safety gate to keep toddlers, young children and other at risk individuals away from hot surfaces.
- Clothing or other flammable material should not be placed on or near the appliance.
- Furniture or other objects must be kept a minimum of 4 feet away from the front of the appliance.
- Ensure you have incorporated adequate safety measures to protect infants/toddlers from touching hot surfaces.
- Even after the appliance is off, it will remain hot for an extended period of time.
- Check with your local hearth specialty dealer for safety screens and hearth guards to protect children from hot surfaces. These screens and guards must be fastened to the floor.
- Any safety screen or guard removed for servicing must be replaced prior to operating the appliance.
- It is imperative that the control compartments, burners and circulating blower and its passageway in the appliance and venting system are kept clean. The appliance should be inspected before use and at least annually by a qualified service person. The appliance area must be kept clear and free from combustible materials, gasoline and other flammable vapors and liquids.
- Under no circumstances should this appliance be modified.
- Do not use this appliance if any part has been under water. Immediately call a qualified service technician to inspect the appliance and to replace any part of the control system and any gas control which has been under water.
- Keep the packaging material out of reach of children and dispose of the material in a safe manner. As with all plastic bags, these are not toys and should be kept away from children and infants.
- This appliance must not be installed indoors or within any structure that prevents or inhibits the exhaust gases from dissipating in the outside atmosphere.

3.14A

## 2.1 DIMENSIONS

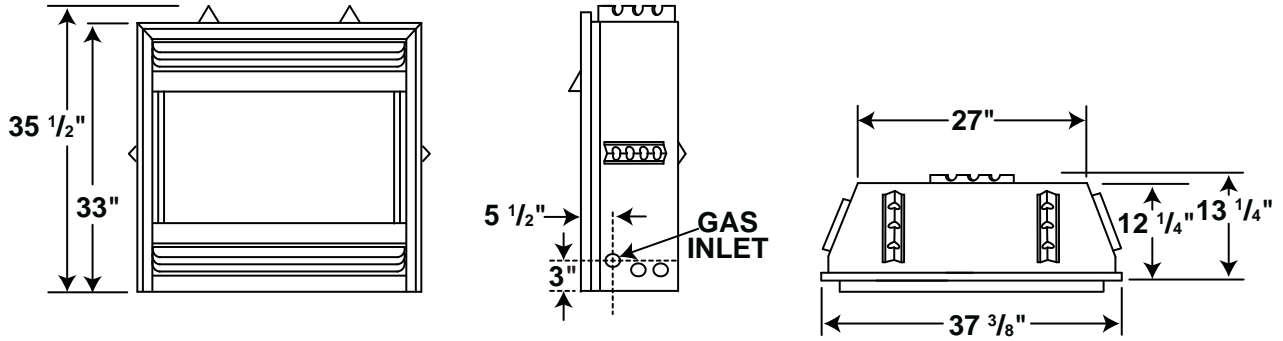

## 2.2 GENERAL INSTRUCTIONS

<b>! WARNING</b>
<b>ALWAYS LIGHT THE PILOT WHETHER FOR THE FIRST TIME OR IF THE GAS SUPPLY HAS RAN OUT, WITH THE GLASS DOOR OPENED OR REMOVED.</b>
<b>NEVER OBSTRUCT THE FRONT OPENING OF THE APPLIANCE.</b>
<b>OBJECTS PLACED IN FRONT OF THE APPLIANCE MUST BE KEPT A MINIMUM OF 48" FROM THE FRONT FACE OF THE APPLIANCE.</b>
<b>FIRE RISK. EXPLOSION HAZARD.</b>
<b>HIGH PRESSURE WILL DAMAGE VALVE. DISCONNECT GAS SUPPLY PIPING BEFORE PRESSURE TESTING GAS LINE AT TEST PRESSURES ABOVE 1/2 PSIG. CLOSE THE MANUAL SHUT-OFF VALVE BEFORE PRESSURE TESTING GAS LINE AT TEST PRESSURES EQUAL TO OR LESS THAN 1/2 PSIG.</b>
<b>USE ONLY WOLF STEEL APPROVED OPTIONAL ACCESSORIES AND REPLACEMENT PARTS WITH THIS APPLIANCE. USING NON-LISTED ACCESSORIES (BLOWERS, DOORS, LOUVRES, TRIMS, GAS COMPONENTS, VENTING COMPONENTS, ETC.) COULD RESULT IN A SAFETY HAZARD AND WILL VOID THE WARRANTY AND CERTIFICATION.</b>
<b>THE APPLIANCE IS ONLY FOR USE WITH THE TYPE OF GAS INDICATED ON THE RATING PLATE. THIS APPLIANCE IS NOT CONVERTIBLE FOR USE WITH OTHER GASES.</b>

**THIS GAS APPLIANCE SHOULD BE INSTALLED AND SERVICED BY A QUALIFIED INSTALLER** to conform with local codes. Installation practices vary from region to region and it is important to know the specifics that apply to your area, for example in Massachusetts State:

- The appliance off valve must be a "T" handle gas cock.
- The flexible connector must not be longer than 36 inches.

The installation must conform with local codes or, in absence of local codes, the National Gas and Propane Installation Code CSA B149.1 in Canada, or the National Fuel Gas Code, ANSI Z223.1 / NFPA 54 in the United States.

**NATIONAL  
FIREPLACE  
INSTITUTE**



**CERTIFIED**  
[www.nficertified.org](http://www.nficertified.org)

We suggest that our gas hearth products be installed and serviced by professionals who are certified in the U.S. by the National Fireplace Institute® (NFI) as NFI Gas Specialists

## 4.3A

The appliance and its individual shutoff valve must be disconnected from the gas supply piping system during any pressure testing of that system at test pressures in excess of 1/2 psig (3.5 kPa). The appliance must be isolated from the gas supply piping system by closing its individual manual shutoff valve during any pressure testing of the gas supply piping system at test pressures equal to or less than 1/2 psig (3.5 kPa).

When the appliance is installed directly on combustible material other than wood flooring, the appliance shall be installed on a metal or wood panel extending the full width and depth.

2.3 GENERAL INFORMATION

**FOR YOUR SATISFACTION, THIS APPLIANCE HAS BEEN TEST-FIRED TO ASSURE ITS OPERATION AND QUALITY!**

RATES AND EFFICIENCIES		
	NATURAL GAS	PROPANE GAS
Altitude	0 - 2,000*	0 - 2,000*
Maximum Input	40,000 BTU/hr	40,000 BTU/hr
Minimum Inlet Gas Supply Pressure	4.5" Water Column	11" Water Column
Maximum Inlet Gas Supply Pressure	7" Water Column	13" Water Column
Manifold Pressure Under Flow Conditions	3.5" Water Column	10" Water Column

\* When the appliance is installed at elevations above 2,000ft, and in the absence of specific recommendations from the local authority having jurisdiction, the certified high altitude input rating shall be reduced at the rate of 4% for each additional 1,000ft.

It is highly recommended to protect the logs from moisture (rain, snow). Cover the enclosure opening when not in use.

This appliance is only for use with the type of gas indicated on the rating plate. This appliance is not convertible for use with other gases, unless a certified kit is used.

No external electricity (110 volts or 24 volts) is required for the gas system operation.

Expansion / contraction noises during heating up and cooling down cycles are normal and are to be expected.

2.4 RATING PLATE INFORMATION

For rating plate location, see "INSTALLATION OVERVIEW" section.

This illustration is for reference only. Refer to the rating plate on the appliance for accurate information.

CERTIFIED UNDER / HOMOLOGUÉ SELON LES NORMES: CGA CR97-003 (July, 1997) CSA US Req. 4-96, 3rd Ed. OUTDOOR GAS FIREPLACE / FOYER AU GAZ EXTÉRIEUR

IF APPLIANCE HAS BEEN SUPPLIED WITH A GAS PRESSURE REGULATOR, IT MUST BE USED. THE GAS SUPPLY MUST BE TURNED OFF AT THE LP-GAS SUPPLY CYLINDER WHEN THIS APPLIANCE IS NOT IN USE. DO NOT STORE OR USE GASOLINE OR OTHER FLAMMABLE VAPOURS AND LIQUIDS IN THE VICINITY OF THIS OR ANY OTHER APPLIANCE. IMPROPER INSTALLATION, ADJUSTMENT, ALTERATION, SERVICE OR MAINTENANCE CAN CAUSE INJURY OR PROPERTY DAMAGE. REFER TO THE OWNER'S MANUAL PROVIDED WITH THIS APPLIANCE. FOR ASSISTANCE OR ADDITIONAL INFORMATION, CONSULT A QUALIFIED INSTALLER, SERVICE AGENCY OR GAS SUPPLIER. MUST NOT BE USED FOR COOKING. FOR OUTDOOR USE ONLY. IF STORED INDOORS, DETACH AND LEAVE CYLINDER OUTDOORS.

SI L'APPAREIL EST ÉQUIPÉ D'UN RÉGULATEUR DE PRESSION D'ALIMENTATION, IL DOIT ÊTRE UTILISÉ. LORSQUE CET APPAREIL N'EST PAS UTILISÉ, VOUS DEVEZ FERMER L'ALIMENTATION EN GAZ SUR LA BONBONNE DE PROPANE. N'ENTREPOSEZ PAS ET N'UTILISEZ PAS D'ESSENCE OU AUTRES SOLIDES COMBUSTIBLES À PROXIMITÉ DE CET APPAREIL OU TOUT AUTRE LIQUIDE INFLAMMABLE. UNE INSTALLATION NON CONFORME, DES AJUSTEMENTS, DES ALTERATIONS, UN SERVICE OU UN ENTRETIEN INADÉQUATS PEUVENT CAUSER DES DOMMAGES À LA PROPRIÉTÉ OU DES BLESSURES CORPORELLES. RÉFÉREZ-VOUS AU MANUEL D'INSTRUCTIONS FOURNI AVEC CET APPAREIL. POUR DE L'ASSISTANCE OU POUR DES RENSEIGNEMENTS, CONSULTEZ UN INSTALLATEUR QUALIFIÉ, UNE AGENCE D'ENTRETIEN OU LE FOURNISSEUR DE GAZ. NE PAS UTILISER POUR LA CUISSON. POUR L'USAGE EXTÉRIEUR SEULEMENT. SI ENTREPOSÉ À L'INTÉRIEUR, DÉTACHER LA BONBONNE DE PROPANE ET LA LAISSER À L'EXTÉRIEUR.



Intertek

9700539 (WSL)  4001657 (NGZ)  4001658 (NAC)  4001659 (WUSA)

GSS36N / CSS36N  MODEL  GSS36P / CSS36P

0-4500FT (0-1370m) ALTITUDE/ELEVATION 0-4500FT (0-1370m)  
 40,000 BTU/h INPUT/ALIMENTATION 40,000 BTU/h  
 20,000 BTU/h REDUCED INPUT/ALIMENTATION RÉDUITE 22,000 BTU/h

MANIFOLD PRESSURE: 3.5" WATER COLUMN / MANIFOLD PRESSURE: 10" WATER COLUMN  
 PRESSION AU COLLECTEUR: 3.5" D'UNE COLONNE D'EAU / PRESSION AU COLLECTEUR: 10" D'UNE COLONNE D'EAU  
 MINIMUM SUPPLY PRESSURE: 4.5" WATER COLUMN / MINIMUM SUPPLY PRESSURE: 11" WATER COLUMN  
 PRESSION D'ALIMENTATION MINIMALE: 4.5" D'UNE COLONNE D'EAU / PRESSION D'ALIMENTATION MINIMALE: 11" D'UNE COLONNE D'EAU  
 MAXIMUM SUPPLY PRESSURE: 7" WATER COLUMN / MAXIMUM SUPPLY PRESSURE: 13" WATER COLUMN  
 PRESSION D'ALIMENTATION MAXIMALE: 7" D'UNE COLONNE D'EAU / PRESSION D'ALIMENTATION MAXIMALE: 13" D'UNE COLONNE D'EAU

**NOT FOR USE WITH SOLID FUEL / UN COMBUSTIBLE SOLIDE NE DOIT PAS ÊTRE UTILISÉ AVEC CET APPAREIL**

**WARNING:** THIS FIREPLACE USES AND REQUIRES A FAST ACTING THERMOCOUPLE. REPLACE ONLY WITH A FAST ACTING THERMOCOUPLE SUPPLIED BY WOLF STEEL LTD. DO NOT ADD ANY MATERIAL TO THE APPLIANCE, WHICH WILL COME IN CONTACT WITH THE FLAMES, OTHER THAN THAT SUPPLIED BY THE MANUFACTURER WITH THE APPLIANCE.

**AVERTISSEMENT:** CE FOYER UTILISE ET REQUIERT UN THERMOCOUPLE À ACTION RAPIDE. REMPLACEZ UNIQUEMENT AVEC UN THERMOCOUPLE À ACTION RAPIDE DE WOLF STEEL L'ÉE. N'AJOUTEZ PAS À CET APPAREIL AUCUN MATÉRIEL DEVANT ENTRER EN CONTACT AVEC LES FLAMMES AUTRE QUE CELUI QUI EST FOURNI AVEC CET APPAREIL PAR LE FABRICANT.

MINIMUM CLEARANCE TO COMBUSTIBLE MATERIALS:  
 TOP 0" BACK 0" FLOOR 0" MANTEL 12" SIDES 0" RECESS/DEPTH 13 1/2"

DÉGAGEMENTS MINIMAUX DES MATÉRIEAUX COMBUSTIBLES:  
 DESSUS 0" ARRIÈRE 0" PLANCHER 0" MANTEAU 12" CÔTÉS 0" PROFONDEUR D'ENCASTRE 13 1/2"

\*MAXIMUM HORIZONTAL EXTENSION: 2". SEE INSTRUCTION MANUAL FOR GREATER EXTENSIONS.

\*L'EXTENSION HORIZONTALE MAXIMALE: 2". RÉFÉREZ AU MANUEL D'INSTRUCTION POUR DES EXTENSIONS PLUS GRANDES.

**WOLF STEEL LTD.**  
 24 NAPOLEON ROAD, BARRIE, ONTARIO, CANADA

SERIAL NUMBER/NO. DE SÉRIE: **GSS36/CSS36**

W385-0275 / J

## 3.0 INSTALLATION

### 3.1 GAS INSTALLATION

<b>! WARNING</b>
<b>RISK OF FIRE, EXPLOSION OR ASPHYXIATION. ENSURE THERE ARE NO IGNITION SOURCES SUCH AS SPARKS OR OPEN FLAMES.</b>
<b>SUPPORT GAS CONTROL WHEN ATTACHING GAS SUPPLY PIPE TO PREVENT DAMAGING GAS LINE.</b>
<b>ALWAYS LIGHT THE PILOT WHETHER FOR THE FIRST TIME OR IF THE GAS SUPPLY HAS RUN OUT WITH THE GLASS DOOR OPENED OR REMOVED. PURGING OF THE GAS SUPPLY LINE SHOULD BE PERFORMED BY A QUALIFIED SERVICE TECHNICIAN. ASSURE THAT A CONTINUOUS GAS FLOW IS AT THE BURNER BEFORE CLOSING THE DOOR. ENSURE ADEQUATE VENTILATION. FOR GAS AND ELECTRICAL LOCATIONS, SEE "DIMENSION" SECTION.</b>
<b>ALL GAS CONNECTIONS MUST BE CONTAINED WITHIN THE APPLIANCE WHEN COMPLETE.</b>
<b>HIGH PRESSURE WILL DAMAGE VALVE. DISCONNECT GAS SUPPLY PIPING BEFORE TESTING GAS LINE AT TEST PRESSURES ABOVE 1/2 PSIG.</b>
<b>VALVE SETTINGS HAVE BEEN FACTORY SET, DO NOT CHANGE.</b>

Installation and servicing to be done by a qualified installer.

- A. Move the appliance into position and secure.
- B. If equipped with a flex connector the appliance is designed to accept a 1/2" gas supply. Without the connector it is designed to accept a 3/8" gas supply. The appliance is equipped with a manual shut off valve to turn off the gas supply to the appliance.
- C. Connect the gas supply in accordance to local codes. In the absence of local codes, install to the current CAN/CSA-B149.1 Installation Code in Canada or to the current National Fuel Gas Code, ANSI Z223.1 / NFPA 54 in the United States.
- D. When flexing any gas line, support the gas valve so that the lines are not bent or kinked.
- E. The gas line flex-connector should be installed to provide sufficient movement for shifting the burner assembly on it's side to aid with servicing components.
- F. Check for gas leaks by brushing on a soap and water solution. **Do not use open flame.**

30.1A

### 3.2 OPTIONAL WALL SWITCH INSTALLATION

<b>! WARNING</b>
<b>DO NOT CONNECT EITHER THE WALL SWITCH, THERMOSTAT OR GAS VALVE DIRECTLY TO 110 VOLT ELECTRICITY.</b>

For ease of accessibility, an optional remote wall switch or millivolt thermostat may be installed in a convenient location. Route a 2 strand, solid core millivolt wire from the valve to the wall switch or millivolt thermostat. The recommended maximum lead length depends on wire size:

<b>WIRE SIZE</b>	<b>MAX. LENGTH</b>
14 gauge	100 feet
16 gauge	60 feet
18 gauge	40 feet

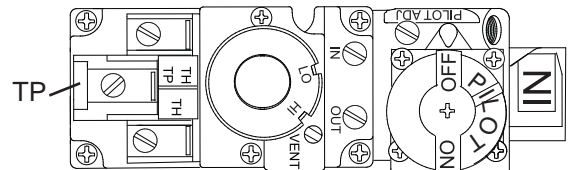

Disconnect the existing wires from terminals 1 and 3 (from the ON/OFF switch) and replace with the leads from the wall switch / millivolt thermostat.

50.3

### 3.3 COMBUSTION AND VENTILATION AIR

This appliance is intended for installation on an outdoor patio or in your yard. It must never be installed inside the warm air envelope of your structure.

It is highly recommended that this appliance be installed in a “sheltered” area. Direct wind will cause an erratic flame and possible pilot or main burner outage.

An erratic flame could also lead to excessive carboning (black soot), this condition is not a safety issue but is visually undesirable.

Typical installation may include covered patio, screened porch, gazebo or on an outside the wall of a house.\*

**NOTE:** Ensure the area has adequate ventilation.

## 4.0 FRAMING

### 4.1 CLEARANCE TO COMBUSTIBLES

 <b>WARNING</b>
<b>RISK OF FIRE!</b>
<b>IN ORDER TO AVOID THE POSSIBILITY OF EXPOSED INSULATION OR VAPOUR BARRIER COMING IN CONTACT WITH THE APPLIANCE BODY, IT IS RECOMMENDED THAT THE WALLS OF THE APPLIANCE ENCLOSURE BE “FINISHED” (IE: DRYWALL / SHEETROCK), AS YOU WOULD FINISH ANY OTHER OUTSIDE WALL OF A HOME. THIS WILL ENSURE THAT CLEARANCE TO COMBUSTIBLES IS MAINTAINED WITHIN THE CAVITY.</b>
<b>DO NOT NOTCH THE FRAMING AROUND THE APPLIANCE STAND-OFFS. FAILURE TO MAINTAIN AIR SPACE CLEARANCE MAY CAUSE OVER HEATING AND FIRE. PREVENT CONTACT WITH SAGGING OR LOOSE INSULATION OR FRAMING AND OTHER COMBUSTIBLE MATERIALS. BLOCK OPENING INTO THE CHASE TO PREVENT ENTRY OF BLOWN-IN INSULATION. MAKE SURE INSULATION AND OTHER MATERIALS ARE SECURED.</b>
<b>WHEN CONSTRUCTING THE ENCLOSURE ALLOW FOR FINISHING MATERIAL THICKNESS TO MAINTAIN CLEARANCES. FRAMING OR FINISHING MATERIAL CLOSER THAN THE MINIMUMS LISTED MUST BE CONSTRUCTED ENTIRELY OF NON-COMBUSTIBLE MATERIALS. MATERIALS CONSISTING ENTIRELY OF STEEL, IRON, BRICK, TILE, CONCRETE, SLATE, GLASS OR PLASTERS, OR ANY COMBINATION THEREOF ARE SUITABLE. MATERIALS THAT ARE REPORTED AS PASSING ASTM E 136, STANDARD TEST METHOD FOR BEHAVIOUR OF MATERIALS IN A VERTICAL TUBE FURNACE AT 750°C AND UL763 SHALL BE CONSIDERED NON-COMBUSTIBLE MATERIALS.</b>
<b>MINIMUM CLEARANCE TO COMBUSTIBLES MUST BE MAINTAINED OR A SERIOUS FIRE HAZARD COULD RESULT.</b>
<b>THE APPLIANCE REQUIRES A MINIMUM ENCLOSURE HEIGHT. MEASURE FROM THE APPLIANCE BASE.</b>
<b>IF STEEL STUD FRAMING KITS WITH CEMENT BOARD ARE PROVIDED, THEY MUST BE INSTALLED.</b>

71.1

\* If installing a propane appliance the propane cylinder must always be on the exterior of such a structure.

**Minimum Clearance to Combustibles construction from appliance and vent surfaces:**

Framing	0" to stand-offs
Finishing	0" to back, sides and bottom
Non-combustible finishing	4 1/2" to top
Recessed depth	13 1/4"
Enclosure top	39 1/4" from bottom of appliance
Clearance to ceiling	84" from bottom of appliance.

It is recommended that the walls of the appliance enclosure be finished. This would ensure that clearance to combustibles is maintained within the cavity.

It is best to frame your appliance after it is positioned. Use 2x4's and frame to local building codes.

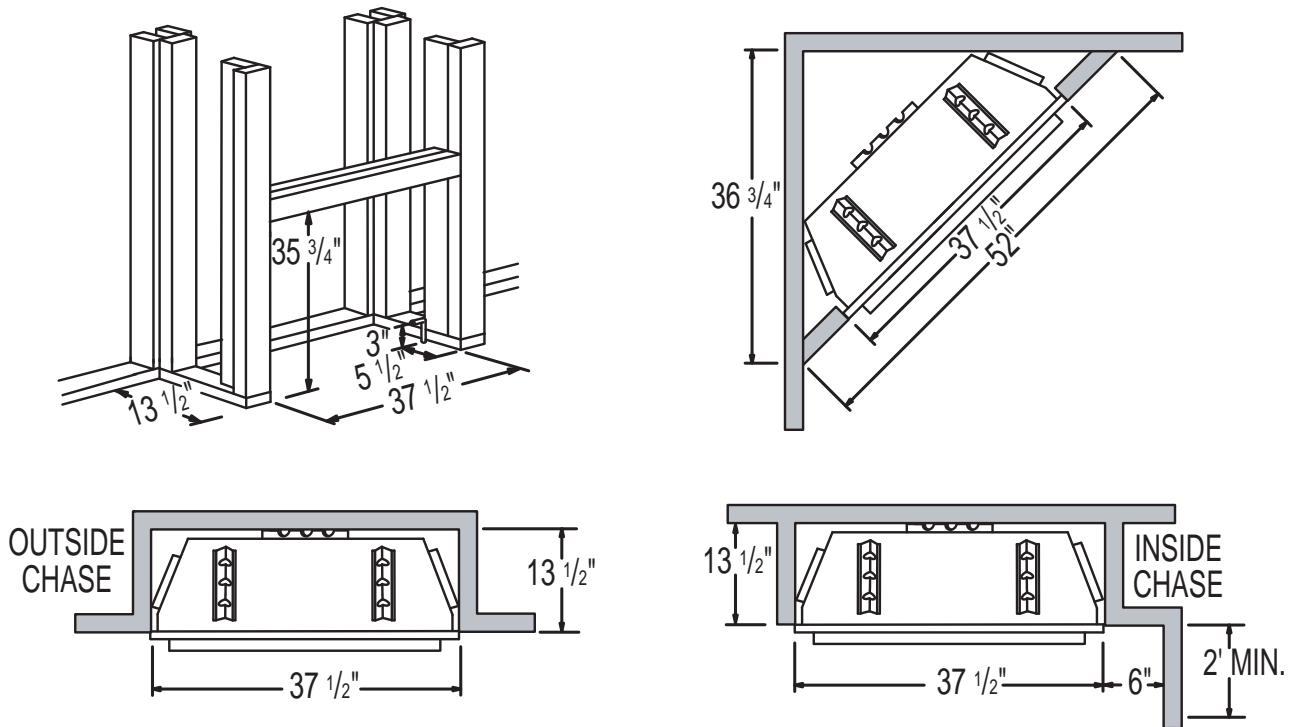



**! WARNING**

**USE ONLY NON-COMBUSTIBLE MATERIAL SUCH AS CEMENT BOARD, CERAMIC TILE, MARBLE, ETC. WHEN FINISHING TO THE APPLIANCE. DO NOT USE WOOD OR DRYWALL.**

Combustible materials may be installed flush with the front of the appliance but must not cover any of the outer frame face-areas of the appliance. Non-combustible material (brick, stone or ceramic tile) may protrude in these areas.

It is not necessary to install a hearth extension with this appliance.

When roughing in the appliance, raise the appliance to accommodate for the thickness of the finished floor materials, i.e. tile, carpeting, hard wood, which if not planned for will interfere with the opening of the lower access door and the installation of many decorative flashing accessories.

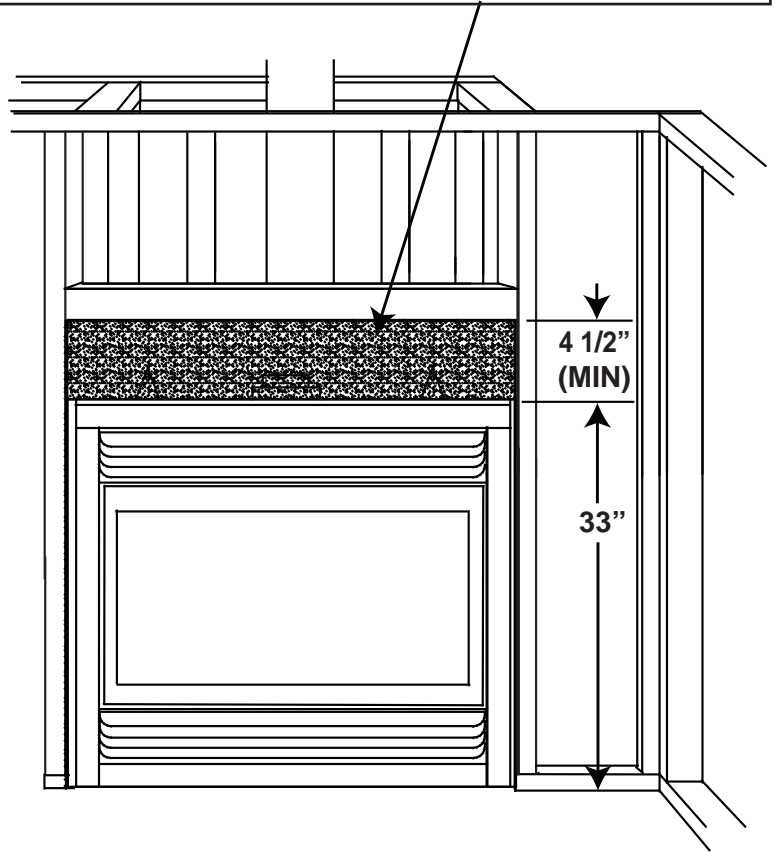

## 4.2 MINIMUM ENCLOSURE CLEARANCES

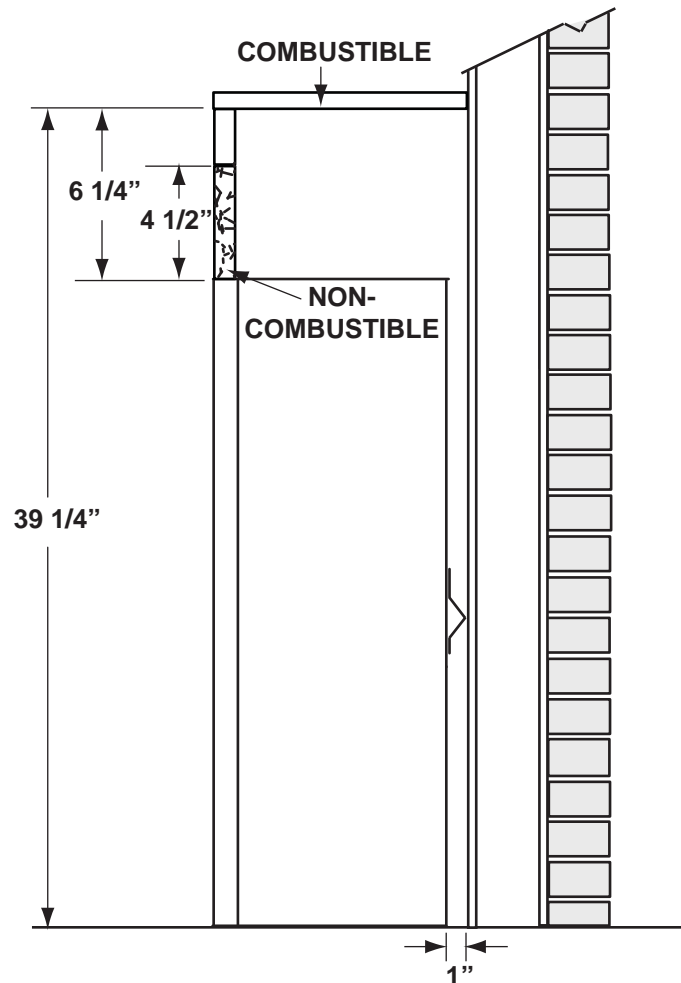

The appliance requires a minimum enclosure height of 39 1/4". For temperature requirements, the enclosure space around and above the appliance must be left unobstructed.

### 4.3 MINIMUM MANTEL CLEARANCES

**! WARNING**

**RISK OF FIRE, MAINTAIN ALL SPECIFIED AIR SPACE CLEARANCES TO COMBUSTIBLES. FAILURE TO COMPLY WITH THESE INSTRUCTIONS MAY CAUSE A FIRE OR CAUSE THE APPLIANCE TO OVERHEAT. ENSURE ALL CLEARANCES (I.E. BACK, SIDE, TOP, VENT, MANTEL, FRONT, ETC.) ARE CLEARLY MAINTAINED.**

**WHEN USING PAINT OR LACQUER TO FINISH THE MANTEL, THE PAINT OR LACQUER MUST BE HEAT RESISTANT TO PREVENT DISCOLOURATION.**

73.1

We recommend all mantels made from non-combustible material. If using combustible materials, follow the chart below.

**NOTE:** Mantel temperatures will rise above normal temperatures and may be hot to the touch.

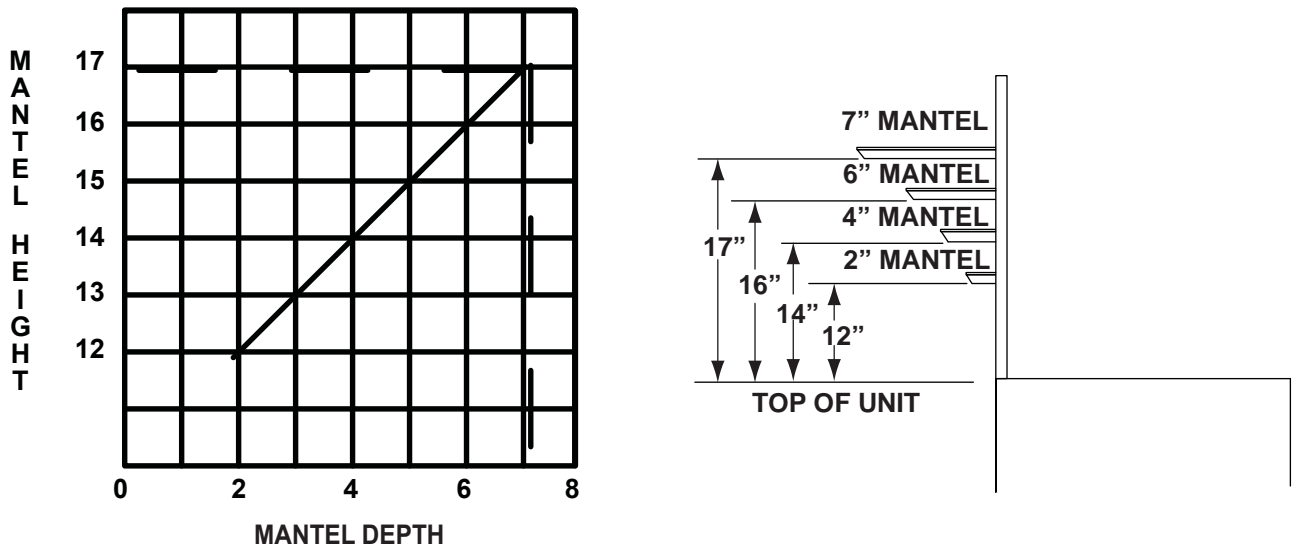

### 4.4 NAILING TAB

To install the appliance face flush with the finished surface, position the framework to accommodate the thickness of the finished surface. Bend out the four nailing tabs, attached on either side of the appliance and secure to the 2x4 framing. The tabs will facilitate the installation of either a 3/4" or a 1" finished surface thickness. The nailing tabs must not be removed.

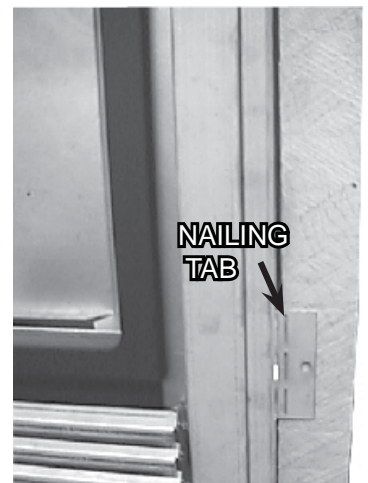

## 5.0 FINISHING

### 5.1 LOG PLACEMENT

#### **! WARNING**

**FAILURE TO POSITION THE LOGS IN ACCORDANCE WITH THESE DIAGRAMS OR FAILURE TO USE ONLY LOGS SPECIFICALLY APPROVED WITH THIS APPLIANCE MAY RESULT IN PROPERTY DAMAGE OR PERSONAL INJURY.**

**LOGS MUST BE PLACED IN THEIR EXACT LOCATION IN THE APPLIANCE. DO NOT MODIFY THE PROPER LOG POSITIONS, SINCE APPLIANCE MAY NOT FUNCTION PROPERLY AND DELAYED IGNITION MAY OCCUR.**

**THE LOGS ARE FRAGILE AND SHOULD BE HANDLED WITH CARE.**

76.1A

*PHAZER™* logs and glowing embers exclusive to Napoleon, provide a unique and realistic glowing effect that is different in every installation. Take the time to carefully position the glowing embers for a maximum glowing effect. Log colours may vary. During the initial use of the appliance, the colours will become more uniform as colour pigments burn in during the heat activated curing process.

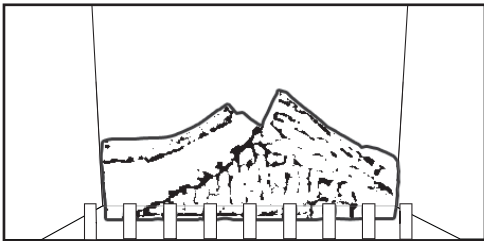

- A.** Place the rear log so that it rests against the two log brackets on the back wall of the firebox. The air space between the log and firebox back is used to facilitate combustion air flow.



- B.** Move the charcoal strip into position lining up the holes in the bottom with the studs located on the burner on the burner. Ensure strip sits flat on the burner.

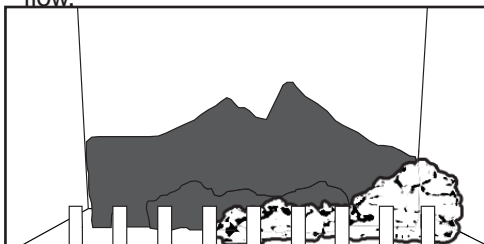

- C.** Position the front right log just behind the grate lining up the holes in the bottom with the studs located on the log support.

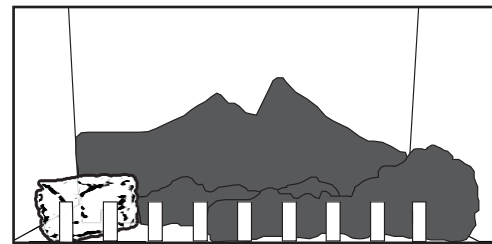

- D.** Move the left log into position lining up the hole in the bottom with the stud on the left side of the log support.

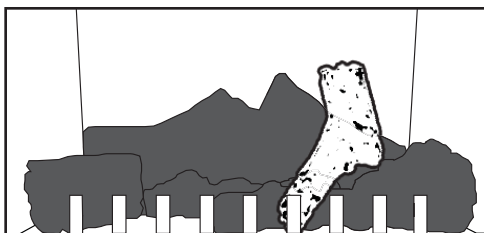

- E.** Line up the square hole in the right crossover with the square post located on the right side of log and install as shown.

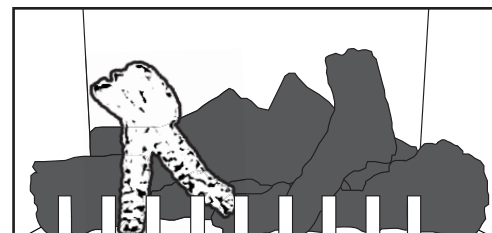

- F.** Line up the rectangular hole in the left crossover with the rectangular post located on the left side of log and install as shown.

#### **IMPORTANT**

**IT IS HIGHLY RECOMMENDED TO PROTECT THE LOGS FROM MOISTURE.  
COVER THE FIREBOX WHEN NOT IN USE.**

## 5.2 HOOD

The curtain mesh must be kept fully closed during operation to help prevent accidental burns from occurring.

**The heater must not be used when the hood is removed.** Hook the hood over the lip of the curtain support plate.

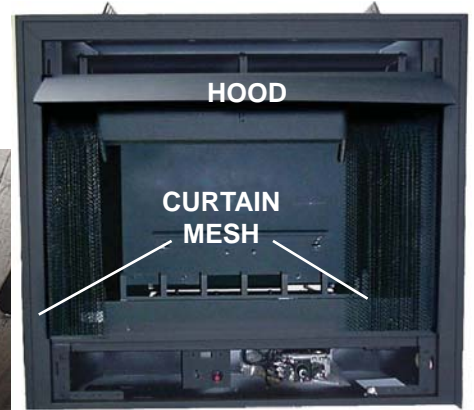

## 5.3 LOGO PLACEMENT

Remove the backing of the logo supplied and place on the screen cover, as indicated.



## 5.4 LOUVRE INSTALLATION

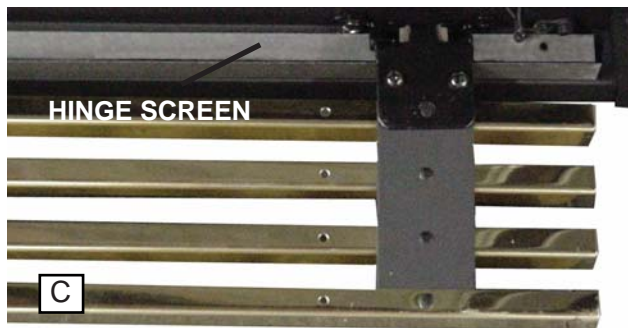

**HINGE SCREEN:** Position the hinge screen into place and with the control door open, secure to the firebox using three screws.

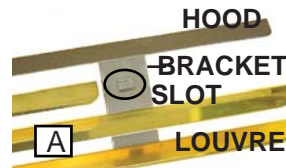

**UPPER LOUVRES:** Insert the upper louvres into the slots on both brackets. Press the top flange of the hood into the four clips located along the top of the appliance as shown.

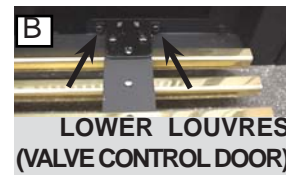

**LOWER LOUVRES:** Attach each hinge to the firebox with 2 screws.

## 6.0 OPERATION

### WARNING

**IF YOU DO NOT FOLLOW THESE INSTRUCTIONS EXACTLY, A FIRE OR EXPLOSION MAY RESULT CAUSING PROPERTY DAMAGE, PERSONAL INJURY OR LOSS OF LIFE.**

When lit for the first time, the appliance will emit an odor for a few hours. This is a normal temporary condition caused by the “burn-in” of paints and lubricants used in the manufacturing process and will not occur again. After extended periods of non-operation such as following a vacation or a warm weather season, the appliance may emit a slight odor for a few hours. This is caused by dust particles in the heat exchanger burning off. In both cases, sufficiently ventilate the area.





#### FOR YOUR SAFETY READ BEFORE LIGHTING:

- A. This appliance is equipped with a pilot which must be lit by hand while following these instructions exactly.
- B. Before operating smell all around the appliance area for gas and next to the floor because some gas is heavier than air and will settle on the floor.
- C. Use only your hand to turn the gas control knob. Never use tools. If the knob will not turn by hand, do not try to repair it. Call a qualified service technician. Force or attempted repair may result in a fire or explosion.
- D. Do not use this appliance if any part has been under water. Immediately call a qualified service technician to inspect the appliance and replace any part of the control system and any gas control which has been under water.

#### WHAT TO DO IF YOU SMELL GAS:

- Do not use a mobile or land phone.
- If you cannot reach your gas supplier, call the fire department.
- Do not try to light any appliance.
- Immediately call your gas supplier from a neighbour's phone. Follow the gas supplier's instructions.
- Turn off all gas to the appliance.

#### LIGHTING INSTRUCTIONS:

1. Stop! Read the above safety information on this label.
2. Turn the gas knob clockwise  to off.
3. Wait five (5) minutes to clear out any gas. If you smell gas including near the floor, **STOP!** Follow “B” in the above safety information on this label. If you don't smell gas go to the next step.
4. If the appliance is equipped with flame adjustment valve turn clockwise  to off.
5. Find pilot located in front of back log.
6. Turn gas knob counter-clockwise  to pilot.
7. Depress and hold gas knob while lighting the pilot with the push button igniter. Keep knob fully depressed for one minute, then release. If pilot does not continue to burn repeat steps 3 through 7.
8. With pilot lit, turn gas knob counter-clockwise  to on.
9. If equipped with flame adjustment valve, push and turn knob to high.
10. If equipped with remote on-off switch, main burner may not come on when you turn the valve to on or high. Remote switch must be in the on position to ignite burner.

#### TO TURN OFF GAS:

Push in gas control knob slightly and turn clockwise  to off. **DO NOT FORCE.**

47.9

# 7.0 ADJUSTMENT

## 7.1 VENTURI ADJUSTMENT

**! WARNING**  
**CARBON CAN BE DISTRIBUTED IN SURROUNDING LIVING AREA IF THE AIR SHUTTER IS IMPROPERLY ADJUSTED.**

This appliance has an air shutter that has been factory set open according to the chart below:

Regardless of venturi orientation, closing the air shutter will cause a more yellow flame, but can lead to carboning. Opening the air shutter will cause a more blue flame, but can cause flame lifting from the burner ports. The flame may not appear yellow immediately; allow 15 to 30 minutes for the final flame colour to be established.

**AIR SHUTTER ADJUSTMENT MUST ONLY BE DONE BY A QUALIFIED INSTALLER!**

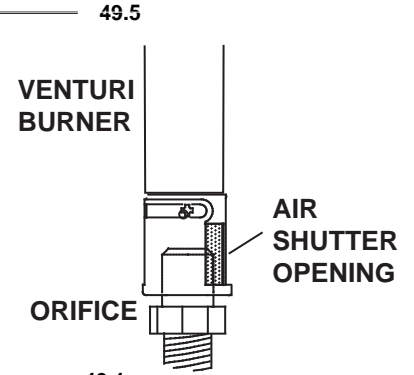

GSS36	
NG	3/16"
LP	1/4"

## 7.2 FLAME CHARACTERISTICS

It's important to periodically perform a visual check of the pilot and burner flames. Compare them to the illustrations provided. If any flames appear abnormal call a service person.

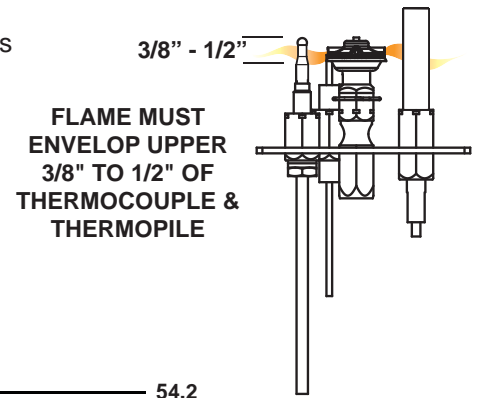

## 8.0 MAINTENANCE

### **WARNING**

**TURN OFF THE GAS AND ELECTRICAL POWER BEFORE SERVICING THE APPLIANCE.**

**APPLIANCE MAY BE HOT, DO NOT SERVICE UNTIL APPLIANCE HAS COOLED.**

**DO NOT USE ABRASIVE CLEANERS.**

**CAUTION:** Label all wires prior to disconnection when servicing controls. Wiring errors can cause improper and dangerous operation. Verify proper operation after servicing. This appliance and its venting system should be inspected before use and at least annually by a qualified service person. The appliance area must be kept clear and free of combustible materials, gasoline or other flammable vapors and liquids. The flow of combustion and ventilation air must not be obstructed.

1. In order to properly clean the burner and pilot assembly, remove the logs, rocks and/or glass to expose both assemblies.
2. Keep the control compartment, media, burner, air shutter opening and the area surrounding the logs clean by vacuuming or brushing, at least once a year.
3. Check to see that all burner ports are burning. Clean out any of the ports which may not be burning or are not burning properly.
4. Check to see that the pilot flame is large enough to engulf the flame sensor and/or thermocouple / thermopile as well as reaches the burner.
5. Replace the cleaned logs, rocks or glass. Failure to properly position the media may cause carboning which can be distributed in the surrounding living area.
6. Check to see that the main burner ignites completely on all openings when turned on. A 5 to 10 second total light-up period is satisfactory. If ignition takes longer, consult your local authorized dealer / distributor.

40.16

Stainless steel tends to oxidize or stain in the presence of chlorides and sulfides, particularly in coastal areas and other harsh environments, such as the warm, highly humid atmosphere around pools and hot tubs. These stains could be perceived as rust, but can be easily removed or prevented. To provide stain prevention and removal, wash all stainless steel surfaces every 3-4 weeks or as often as required with fresh water and/or stainless steel cleaner.

#### **CLEANING THE STAINLESS STEEL SURFACE:**

Do not use abrasive cleaners or steel wool on the stainless steel parts. Doing so will scratch the finish. Surfaces should be cleaned with warm soapy water while the metal is still warm to the touch. To clean stainless surfaces, use a stainless steel or non-abrasive cleaner. Always wipe in the direction of the grain. Over time, stainless steel parts discolour when heated, usually to a golden or brown hue. This discolouration is normal and does not affect the performance of the appliance.

81.1



## 9.0 REPLACEMENTS

### WARNING

**FAILURE TO POSITION THE PARTS IN ACCORDANCE WITH THIS MANUAL OR FAILURE TO USE ONLY PARTS SPECIFICALLY APPROVED WITH THIS APPLIANCE MAY RESULT IN PROPERTY DAMAGE OR PERSONAL INJURY.**

**\*\* THIS IS A FAST ACTING THERMOCOUPLE. IT IS AN INTEGRAL SAFETY COMPONENT. REPLACE ONLY WITH A FAST ACTING THERMOCOUPLE SUPPLIED BY WOLF STEEL LTD.**

Contact your dealer or the factory for questions concerning prices and policies on replacement parts. Normally all parts can be ordered through your Authorized dealer / distributor.

**FOR WARRANTY REPLACEMENT PARTS, A PHOTOCOPY OF THE ORIGINAL INVOICE WILL BE REQUIRED TO HONOUR THE CLAIM.**

When ordering replacement parts always give the following information:

- Model & Serial Number of appliance
- Installation date of appliance
- Part number
- Description of part
- Finish

**\* IDENTIFIES ITEMS WHICH ARE NOT ILLUSTRATED. FOR FURTHER INFORMATION, CONTACT YOUR AUTHORIZED DEALER.**

41.2

### COMPONENTS

REF NO.	PART NO.	DESCRIPTION
1	W357-0001	PIEZO IGNITER
2	W680-0004	THERMOPILE
3	W680-0005	THERMOCOUPLE**
4	W010-0801	NATURAL GAS PILOT ASSEMBLY
4	W010-0800	PROPANE GAS PILOT ASSEMBLY
5	W455-0069	NATURAL GAS PILOT INJECTOR
5	W455-0067	PROPANE GAS PILOT INJECTOR
6	W725-0028	NATURAL GAS VALVE
6	W725-0029	PROPANE GAS VALVE
7*	W385-0334	NAPOLEON® LOGO
8	GL-667	LOG SET
9	W135-0378	BACK LOG (#1)
10	W135-0381	LEFT MIDDLE LOG (#2)
11	W135-0382	RIGHT MIDDLE LOG (#3)
12	W135-0380	LEFT CROSSOVER LOG (#4)
13	W135-0383	CHARCOAL STRIP
14	W135-0379	RIGHT CROSSOVER LOG (#6)
15	W010-1066	PAN BURNER
16	W456-0031	#31 NATURAL GAS BURNER ORIFICE
16	W456-0049	#49 PROPANE GAS BURNER ORIFICE
17	W335-0033	HOOD
18	W565-0062	CURTAIN MESH
19	W555-0040	CURTAIN ROD
20*	W080-0614	CURTAIN ROD BRACKET
21	W500-0209	CURTAIN SUPPORT PLATE
22	W630-0010	BLACK TASSELS
23	W200-0135	FIREBOX COVER
24	N325-0036	COVER HANDLE
25*	W660-0005	SWITCH
26*	W750-0109	3/16" FLAG WIRE ASSEMBLY
27*	W750-0110	1/4" FLAG WIRE ASSEMBLY
28	W010-1037	LOUVRE KIT - STAINLESS STEEL

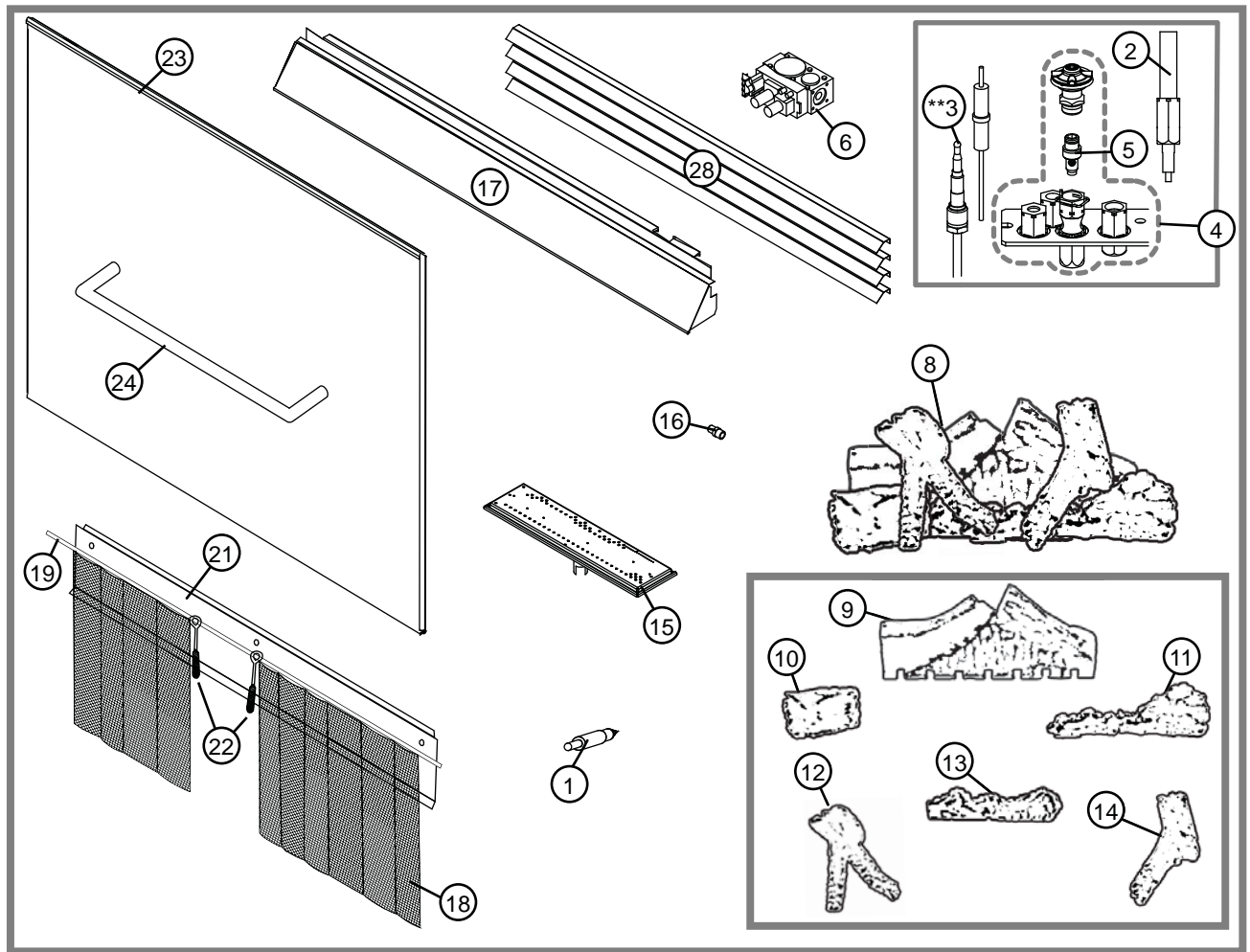

# 10.0 TROUBLESHOOTING

**! WARNING**

**ALWAYS LIGHT THE PILOT WHETHER FOR THE FIRST TIME OR IF THE GAS SUPPLY HAS RAN OUT, WITH THE GLASS DOOR OPEN OR REMOVED.**

---

**TURN OFF THE GAS AND ELECTRICAL POWER BEFORE SERVICING THE APPLIANCE.**

---

**APPLIANCE MAY BE HOT, DO NOT SERVICE UNTIL APPLIANCE HAS COOLED.**

---

**DO NOT USE ABRASIVE CLEANERS.**

SYMPTOM	PROBLEM	TEST SOLUTION	
Main burner goes out; pilot stays on.	Pilot flame is not large enough or not engulfing the thermopile.	<ul style="list-style-type: none"> <li>- Turn up the pilot flame.</li> <li>- Replace pilot assembly.</li> </ul>	
	Thermopile shorting.	<ul style="list-style-type: none"> <li>- Clean thermopile connection to the valve. Reconnect.</li> <li>- Replace thermopile / valve.</li> </ul>	
	Remote wall switch wire is too long; too much resistance in the system.	<ul style="list-style-type: none"> <li>- Shorten wire to correct length or wire gauge.</li> </ul>	
	Faulty thermostat or switch.	<ul style="list-style-type: none"> <li>- Replace.</li> </ul>	
Main burner goes out; pilot goes out.	Refer to "MAIN BURNER GOES OUT; PILOT STAYS ON"		
Pilot goes out when the gas knob is released. <b>The gas valve has an interlock device which will not allow the pilot burner to be lit until the thermocouple has cooled. Allow approximately 60 seconds for the thermocouple to cool.</b>	System is not correctly purged.	<ul style="list-style-type: none"> <li>- Purge the gas line.</li> </ul>	
	Out of propane gas.	<ul style="list-style-type: none"> <li>- Fill the tank.</li> </ul>	
	Pilot flame is not large enough.	<ul style="list-style-type: none"> <li>- Turn up the pilot flame.</li> </ul>	
	Pilot flame is not engulfing the thermocouple	<ul style="list-style-type: none"> <li>- Gently twist the pilot head to improve the flame pattern around the thermocouple.</li> </ul>	
	Thermocouple shorting / faulty.	<ul style="list-style-type: none"> <li>- Loosen and tighten thermocouple.</li> <li>- Clean thermocouple and valve connection.</li> <li>- Replace thermocouple.</li> <li>- Replace valve.</li> </ul>	
Faulty valve.	<ul style="list-style-type: none"> <li>- Replace.</li> </ul>		
Pilot burning; no gas to main burner; gas knob is on 'HI'; wall switch / thermostat is on.	Thermostat or switch is defective	<ul style="list-style-type: none"> <li>- Connect a jumper wire across the wall switch terminals; if main burner lights, replace switch / thermostat.</li> </ul>	
	Wall switch wiring is defective.	<ul style="list-style-type: none"> <li>- Disconnect the switch wires &amp; connect a jumper wire across terminals 1 &amp; 3; if the main burner lights, check the wires for defects and/or replace wires.</li> </ul>	
	Main burner orifice is plugged.	<ul style="list-style-type: none"> <li>- Remove stoppage in orifice.</li> </ul>	
	Faulty valve.	<ul style="list-style-type: none"> <li>- Replace.</li> </ul>	
Pilot will not light.	No spark at pilot burner.	<ul style="list-style-type: none"> <li>- Check if pilot can be lit by a match.</li> <li>- Check that the wire is connected to the push button igniter.</li> <li>- Check if the push button igniter needs tightening.</li> <li>- Replace the wire if the wire insulation is broken or frayed.</li> <li>- Replace the electrode if the ceramic insulator is cracked or broken.</li> <li>- Replace the push button ignitor</li> </ul>	
		Out of propane gas.	<ul style="list-style-type: none"> <li>- Fill the tank.</li> </ul>
		Spark gap is incorrect.	<ul style="list-style-type: none"> <li>- Spark gap should be 0.150" to 0.175" (5/32" to 11/64" approx.) from the electrode tip and the pilot burner. To ensure proper electrode location, tighten securing nut (finger tight plus 1/4 turn).</li> </ul>
		No gas at the pilot burner.	<ul style="list-style-type: none"> <li>- Check that the manual valve is turned on.</li> <li>- Check the pilot orifice for blockage.</li> <li>- Replace the valve.</li> <li>- Call the gas distributor.</li> </ul>

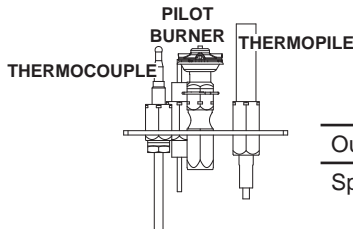

SYMPTOM	PROBLEM	TEST SOLUTION
Pilot goes out while standing; Main burner is in 'OFF' position.	Gas piping is undersized.	<ul style="list-style-type: none"> <li>- Turn on all gas appliances and see if pilot flame flutters, diminishes or extinguishes, especially when main burner ignites. Monitor appliance supply working pressure.</li> <li>- Check if supply piping size is to code. Correct all undersized piping.</li> </ul>
Flames are consistently too large or too small. Carboning occurs.	Unit is over-fired or underfired.	<ul style="list-style-type: none"> <li>- Check pressure readings:</li> <li>- Inlet pressure can be checked by turning screw (A) counter-clockwise 2 or 3 turns and then placing pressure gauge tubing over the test point. Gauge should read 7" (minimum 4.5") water column for natural gas or 13" (minimum 11") water column for propane. Check that main burner is operating on 'HI'.</li> <li>- Outlet pressure can be checked the same as above using screw (B). Gauge should read 3.5" water column for natural gas or 10" water column for propane. Check that main burner is operating on 'HI'.</li> <li>- AFTER TAKING PRESSURE READINGS, BE SURE TO TURN SCREWS CLOCKWISE FIRMLY TO RESEAL. DO NOT OVER TORQUE.</li> <li>- Leak test with a soap and water solution.</li> </ul>
Carbon is being deposited on logs or combustion chamber surfaces.	Air shutter has become blocked.	<ul style="list-style-type: none"> <li>- Ensure air shutter opening is free of lint or other obstructions.</li> </ul>
	Flame is impinging on the logs or combustion chamber.	<ul style="list-style-type: none"> <li>- Check that the logs are correctly positioned.</li> <li>- Open air shutter to increase the primary air.</li> <li>- Check the input rate: check the manifold pressure and orifice size as specified by the rating plate values.</li> </ul>
White / grey film forms.	Sulphur from fuel is being deposited on glass, logs or combustion chamber surfaces.	<ul style="list-style-type: none"> <li>- Clean the glass with a recommended gas appliance glass cleaner.</li> <li>- DO NOT CLEAN GLASS WHEN HOT.</li> <li>- If deposits are not cleaned off regularly, the glass may become permanently marked.</li> </ul>
Remote wall switch is in 'OFF' position; main burner comes on when gas knob is turned to 'ON' position.	Wall switch is mounted upside down.	<ul style="list-style-type: none"> <li>- Reverse.</li> </ul>
	Remote wall switch is grounding.	<ul style="list-style-type: none"> <li>- Replace.</li> </ul>
	Remote wall switch wire is grounding.	<ul style="list-style-type: none"> <li>- Check for ground (short); repair ground or replace wire.</li> </ul>
	Faulty valve.	<ul style="list-style-type: none"> <li>- Replace.</li> </ul>

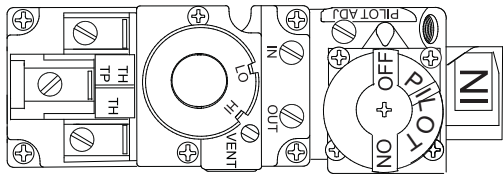

## 11.0 WARRANTY

NAPOLEON® gas appliances are manufactured under the strict Standard of the world recognized ISO 9001 : 2008 Quality Assurance Certificate.

NAPOLEON® products are designed with superior components and materials, assembled by trained craftsmen who take great pride in their work. The burner and valve assembly are leak and test-fired at a quality test station. Once assembled the complete appliance is thoroughly inspected by a qualified technician before packaging to ensure that you, the customer, receives the quality product that you expect from NAPOLEON®.

### NAPOLEON® GAS APPLIANCE 5 YEAR LIMITED WARRANTY

All stainless steel components of your new NAPOLEON® gas appliance are warranted against defects for five years.

All parts such as gas valves, logs, gasketing are covered and NAPOLEON® will provide replacement parts free of charge during the first year of the limited warranty.\*

Labour related to warranty repair is covered free of charge during the first year. Repair work, however, requires the prior approval of an authorized company official. Labour costs to the account of NAPOLEON® are based on a predetermined rate schedule and any repair work must be done through an authorized NAPOLEON® dealer.

\* Construction of models vary. Warranty applies only to components included with your specific appliance.

### CONDITIONS AND LIMITATIONS

NAPOLEON® warrants its products against manufacturing defects to the original purchaser only. Registering your warranty is not necessary. Simply provide your proof of purchase along with the model and serial number to make a warranty claim. NAPOLEON® reserves the right to have its representative inspect any product or part thereof prior to honouring any warranty claim. Provided that the purchase was made through an authorized NAPOLEON® dealer your appliance is subject to the following conditions and limitations:

Warranty coverage begins on the date of original installation.

This limited warranty applies only while the unit remains at the site of original installation, and only if the unit is installed in Canada or the United States.

This factory warranty is nontransferable and may not be extended whatsoever by any of our representatives.

Installation must be done in accordance with the installation instructions included with the product and all local and national building and fire codes.

This limited warranty does not cover damages caused by misuse, lack of maintenance, accident, alterations, abuse or neglect and parts installed from other manufacturers will nullify this warranty.

This limited warranty further does not cover any scratches, dents, corrosion or discolouring caused by excessive heat, abrasive and chemical cleaners, mechanical breakage of logs and embers.

In the first year only, this warranty extends to the repair or replacement of warranted parts which are defective in material or workmanship provided that the product has been operated in accordance with the operation instructions and under normal conditions.

After the first year, with respect to this Limited Warranty, NAPOLEON® may, at its discretion, fully discharge all obligations with respect to this warranty by refunding to the original warranted purchaser the wholesale price of any warranted but defective part(s).

After the first year, NAPOLEON® will not be responsible for installation, labour or any other costs or expenses related to the reinstallation of a warranted part, and such expenses are not covered by this warranty.

Notwithstanding any provisions contained in this Limited Warranty, NAPOLEON'S responsibility under this warranty is defined as above and it shall not in any event extend to any incidental, consequential or indirect damages.

This warranty defines the obligations and liability of NAPOLEON® with respect to the NAPOLEON® gas appliance and any other warranties expressed or implied with respect to this product, its components or accessories are excluded.

This limited warranty does not cover damages resulting from the use of components not supplied with the appliance, or the use of fuel other than those specified.

Any damages to appliance due to weather, long periods of dampness, condensation, damaging chemicals or cleaners will not be the responsibility of NAPOLEON®.

The bill of sale or copy will be required together with a serial number and a model number when making any warranty claims from your authorized dealer. The warranty registration card must be returned within fourteen days to register the warranty.

NAPOLEON® reserves the right to have its representative inspect any product or part thereof prior to honouring any warranty claim.

All parts replaced under the Limited warranty policy are subject to a single claim.

All parts replaced under the warranty will be covered for a period of 90 days from the date of their installation.

The manufacturer may require that defective parts or products be returned or that digital pictures be provided to support the claim. Returned products are to be shipped prepaid to the manufacturer for investigation. If a product is found to be defective, the manufacturer will repair or replace such defect.

Before shipping your appliance or defective components, your dealer must obtain an authorization number. Any merchandise shipped without authorization will be refused and returned to sender.

Shipping costs are not covered under this warranty.

Additional service fees may apply if you are seeking warranty service from a dealer.

Labour, travel, diagnostic tests, shipping and other related charges are not covered by this warranty.

ALL SPECIFICATIONS AND DESIGNS ARE SUBJECT TO CHANGE WITHOUT PRIOR NOTICE DUE TO ON-GOING PRODUCT IMPROVEMENTS.  
NAPOLEON® IS A REGISTERED TRADEMARK OF WOLF STEEL LTD.

**2.9B**







Other products available from your  
Authorized Napoleon® Fireplace Dealer...



Patio Heaters



Fireplace Mantels



HVAC Products



Electric Fireplaces



Outdoor Living Products



Fireplace Accessories

Contact your Authorized Napoleon® dealer or visit [napoleonfireplaces.com](http://napoleonfireplaces.com) for more information.