

Corr/Guard Direct Vent Water Heater Vent/Air Intake System

Installation and service must be performed by a qualified installer, service agency or the gas supplier. Installation must meet all state and local codes regarding installation and location of vent systems for direct vent appliances. The maximum vent length, as stated in the Water Heater Owner's Manual and these instructions, should never be exceeded. Follow the instructions below and all instructions located in the Water Heater Owner's Manual when installing a vent pipe system.

	WARNING	Improper installation of venting pipe, or failure to follow all installation instructions completely, can result in property damage and/or death.
--	----------------	---

Components needed for direct vent applications:

Refer to the following drawings of vent system components and installations to determine the parts required for your particular vent system application:

<p>Standard Vent Discharge Kit (Part No: 3CGRVDK)</p> <p>Vent Pipe Extension (Not Provided With Kit)</p>		<p>Vertical Termination Part No: 3CGRVT</p>	<p>Horizontal Termination Part No: 3CGRHT</p>	<p>Vertical Adapter Part No: 3CGRIA Part No: 3CGRLSV (New)</p>	<p>Horizontal Adapter Part No: 3CGRHA Part No: 3CGRLSH (New)</p>								
<p>6" Vent Pipe Extension Part No: 3CG6</p>	<p>12" Vent Pipe Extension Part No: 3CG12</p>	<p>18" Vent Pipe Extension Part No: 3CG18</p>	<p>Roof Flashing See Roof Pitch Chart Below</p> <table border="1"> <thead> <tr> <th colspan="2">ROOF PITCH</th> </tr> </thead> <tbody> <tr> <td>0/12 TO 1/12</td> <td>3CGFT</td> </tr> <tr> <td>2/12 TO 5/12</td> <td>3CGF</td> </tr> <tr> <td>6/12 TO 12/12</td> <td>3CGF-12</td> </tr> </tbody> </table>			ROOF PITCH		0/12 TO 1/12	3CGFT	2/12 TO 5/12	3CGF	6/12 TO 12/12	3CGF-12
ROOF PITCH													
0/12 TO 1/12	3CGFT												
2/12 TO 5/12	3CGF												
6/12 TO 12/12	3CGF-12												
<p>24" Vent Pipe Extension Part No: 3CG24</p>	<p>36" Vent Pipe Extension Part No: 3CG36</p>	<p>Trim Ring Part No: 3CGTR</p>		<p>Storm Collar Part No: 3CGSC</p>									
<p>45 Degree Vent Pipe Elbow Part No: 3CG45L</p>	<p>90 Degree Vent Pipe Elbow Part No: 3CG90L</p>	<p>Wall Hanger Part No: 3CGWH</p>	<p>Adjustable Vent Pipe Part No: 3CGAL</p>										
<p>Vertical Drain Section Part No: 3CGVDS</p>	<p>Horizontal Drain Section Part No: 3CGDS</p>	<p>Plate Support Part No: 3CGPS</p>	<p>Male To Male Adapter Part No: 3CGDMA</p>	<p>Female To Female Adapter Part No: 3CGDFA</p>									

NOTE: When installed, each connecting vent pipe joint will have 2-1/4" of overlap.

HORIZONTAL VENTING WITH STANDARD VENT DISCHARGE KIT

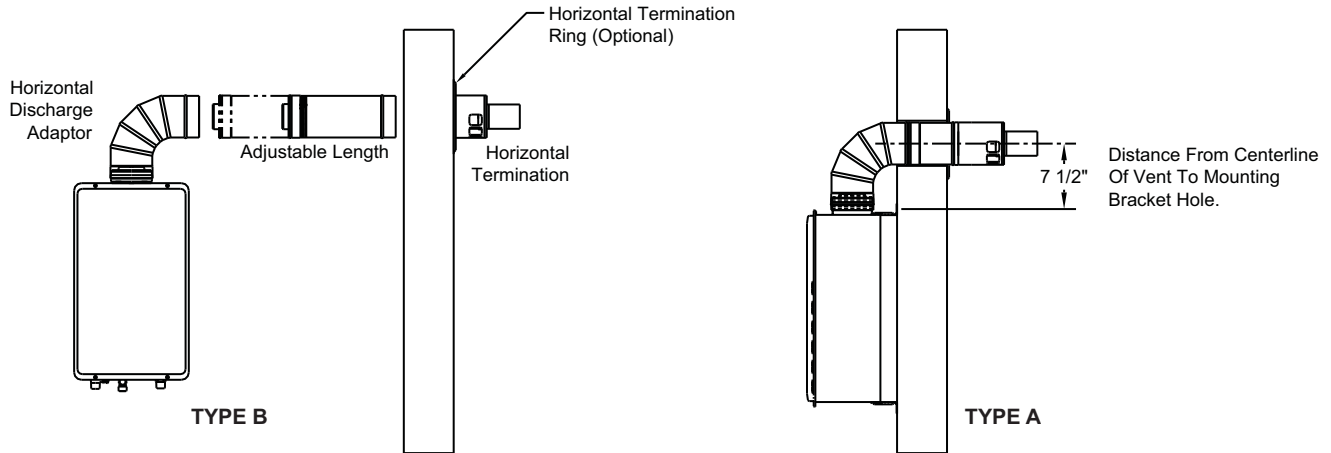

NOTES:

1. Support vent pipe every 7 ft. Vertical pipe will use wall hanger bracket. Horizontal pipe will use plumbers tape.
2. Refer to the appliance manufacturer's installation instructions for allowable vent lengths.

HORIZONTAL VENTING - SLOPE TOWARDS EXHAUST

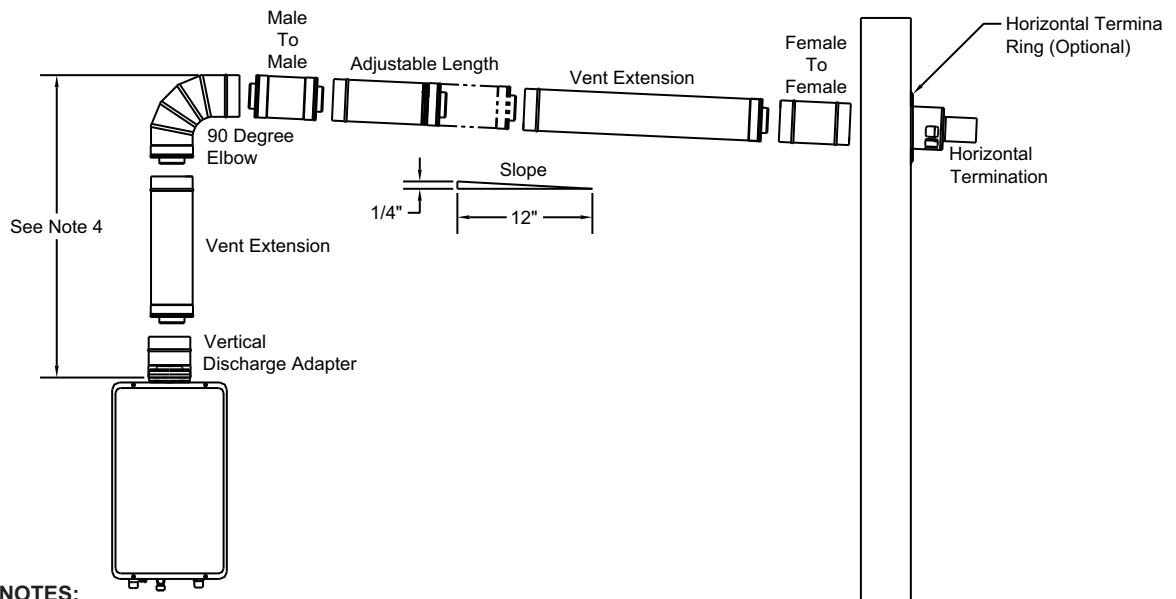

NOTES:

1. Support vent pipe every 7 ft. Vertical pipe will use wall hanger bracket. Horizontal pipe will use plumbers tape.
2. Refer to the appliance manufacturer's installation instructions for allowable vent lengths.
3. Vent must **slope down** towards exhaust a minimum of **1/4" per foot**.
4. Refer to appliance manufacturer's instructions for use of condensate drain section requirements.
5. For installations that slope towards exhaust, use male to male and female to female adaptors to provide proper drain direction of condensate.

HORIZONTAL VENTING - SLOPE TOWARDS APPLIANCE

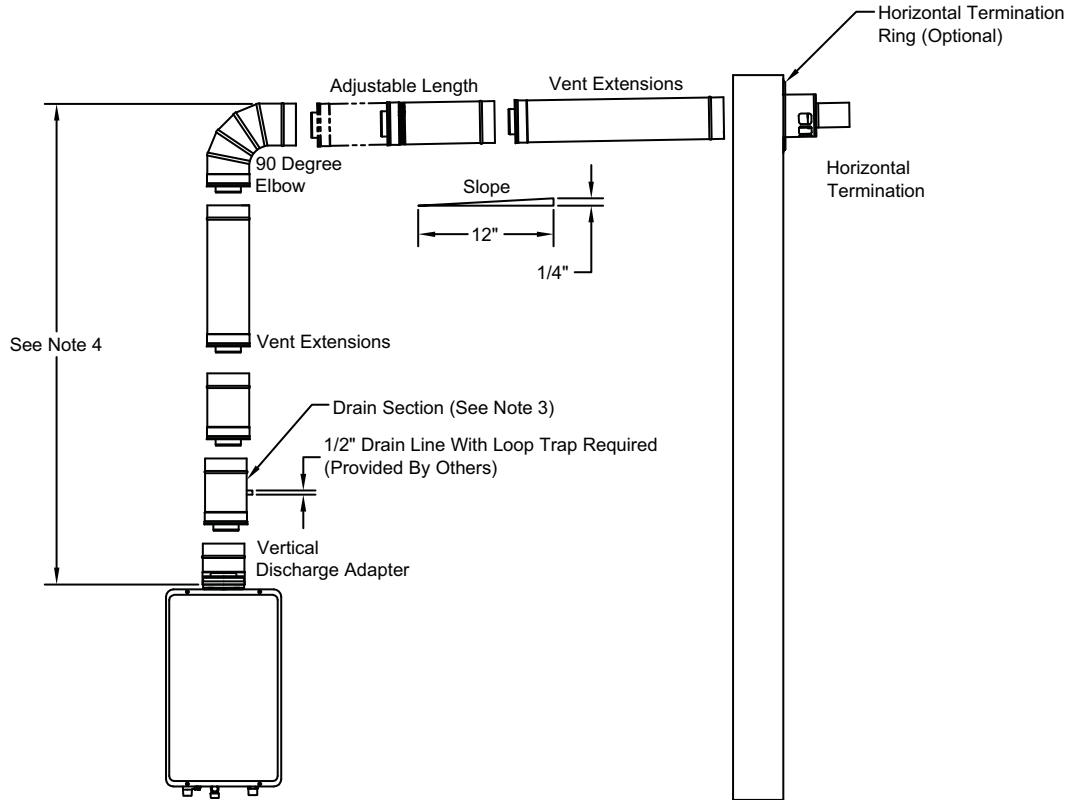

NOTES:

1. Support vent pipe every 7 ft. Vertical pipe will use wall hanger bracket. Horizontal pipe will use plumbers tape.
2. Refer to the appliance manufacturer's installation instructions for allowable vent lengths.
3. Provisions must be made to prevent condensate from entering the water heater. Without proper drainage or disposal condensate will damage the heat exchanger. (Note: Some appliances have built in feature for condensate drain.)
4. Refer to appliance manufacture's instructions for use of condensate drain section requirements.
5. Vent must **slope up towards exhaust** a minimum of **1/4" per foot**.

IMPORTANT NOTE: For Direct Vent applications (venting systems that bring outside combustion air directly to the gas appliance), the outer surface of the direct vent can be in direct contact with combustible construction, unless prohibited per appliance Manufacturer's Installation Instructions. For more information, contact Metal-Fab, Inc. at 1-800-835-2830.

VERTICAL VENTING

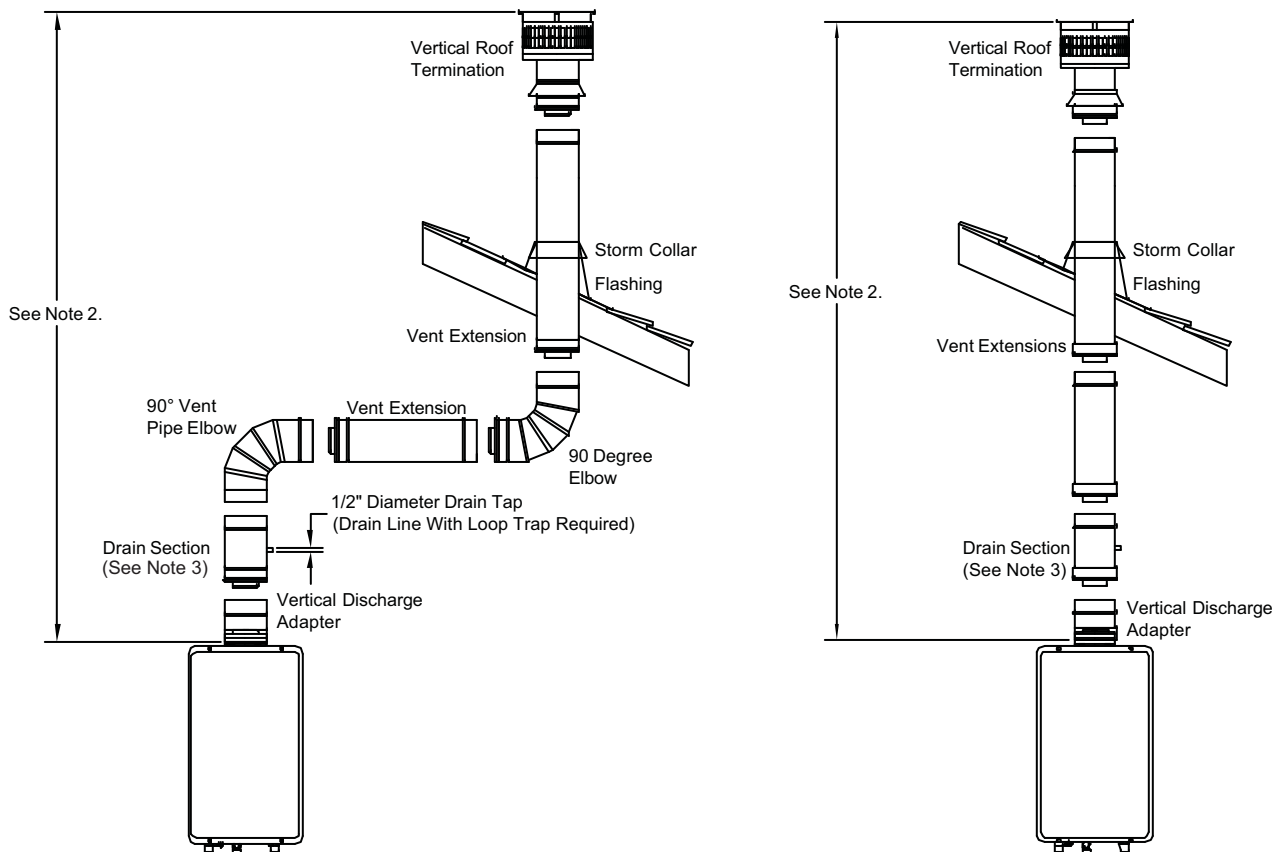

NOTES:

1. Support vent pipe every 7 ft. Vertical pipe will use wall hanger bracket. Horizontal pipe will use plumbers tape.
2. Refer to the appliance manufacturer's installation instructions for allowable vent lengths and maximum vent height.
3. Provisions must be made to prevent condensate from entering the water heater. Without proper drainage or disposal condensate will damage the heat exchanger. (Note: Some appliances have built in feature for condensate drain.)

Refer to the **Water Heater Owner's Manual** for details concerning vent system termination positions and required clearances, allowable vent pipe lengths, and proper dip switch selection for your particular vent pipe system. If you do not understand how to configure your vent pipe system and/or how to set dip switches, please contact Rinnai at 1-800-621-9419 for assistance prior to the installation of direct vent systems.

Your water heater has two adjustable wall mounting support brackets fitted on top and bottom of the appliance. When installing a "Standard Vent Discharge Kit" to vent directly out the wall to the back of the water heater, these brackets should be adjusted so that the water heater is spaced it's maximum distance or 2" away from the wall.

Installation of "Standard Vent Discharge Kit":

Standard Vent Discharge Kit Installation Type A:

Standard Vent Discharge Kit Installation When Mounting To And Venting Directly Out An Exterior Wall.

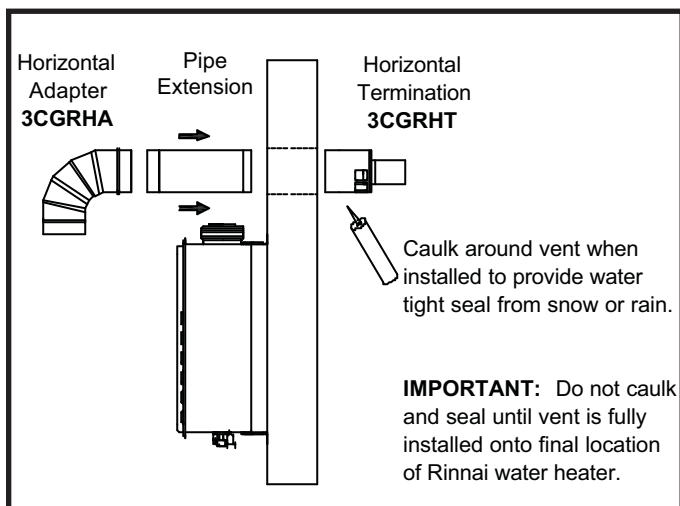

- 1) This step presumes the water heater is installed. Using the template provided (attached at the end of these instructions), locate the preferred area for wall penetration and align with the water heater upper wall mounting bracket holes provided on the template (See **Figure 1**).

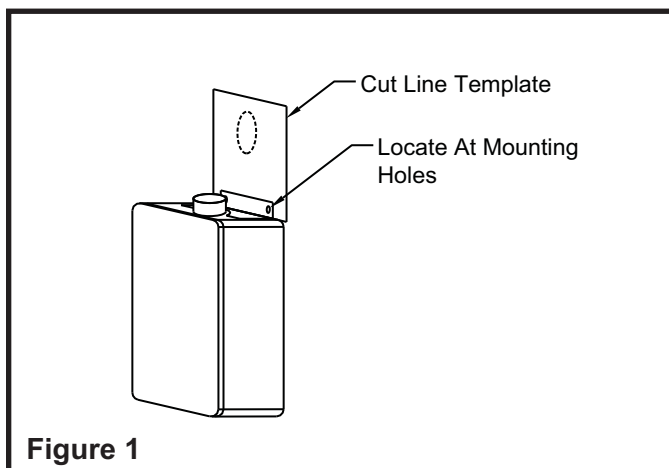

- 2) Tape the template to the wall. Make sure the mounting bracket holes are located exactly over the holes on the upper wall mount bracket of the water heater.
- 3) Using a pencil, or sharp scoring tool, mark the "PILOT HOLE" location by pressing hard enough to penetrate the template leaving a mark on the wall. Removed the template from the wall.

- 4) Remove the water heater from the wall, or completely cover it, using plastic and tape, so that dust or debris will not fall into the vent opening or any of the ventilation slots when cutting the opening through the wall.
- 5) Using a 1/4" or smaller drill bit (long enough to drill completely through wall), drill a pilot hole from the inside wall surface completely through the outside wall surface.

IMPORTANT: Be certain the drill bit is kept level and straight during the drilling operation.

- 6) Using scissors, carefully cut the Wall Discharge Terminal Template along the outside edge of the dashed circle labeled "CUT LINE" leaving the hatched "Cut Line Template".
- 7) Align the "PILOT HOLE" on the "Cut Line Template" with the pilot hole drilled in the wall and using a pencil, carefully trace a cut line on the inside wall surface along the edge of the "Cut Line Template". The cut line circle should be 5-5/16" diameter.
- 8) Repeat Step 7 to trace a cut line on the exterior surface of the wall.
- 9) Using a cutting tool suitable for the wall construction (i.e. drill, skill saw, hole saw, etc.), drill or cut the vent termination hole through the wall along the cut lines drawn in Steps 7 and 8.

- 10) Install the Horizontal Adaptor (3CGRHA) directly onto the water heater vent collar.

IMPORTANT: If finished interior wall exists, the water heater will temporarily need to be lowered 2" to connect the vent onto the outlet collar.

Press vent downward so that at least 1-1/2" overlap occurs and position so that the horizontal end of the vent adaptor is in line with the hole in the wall (See **Figure 2**).

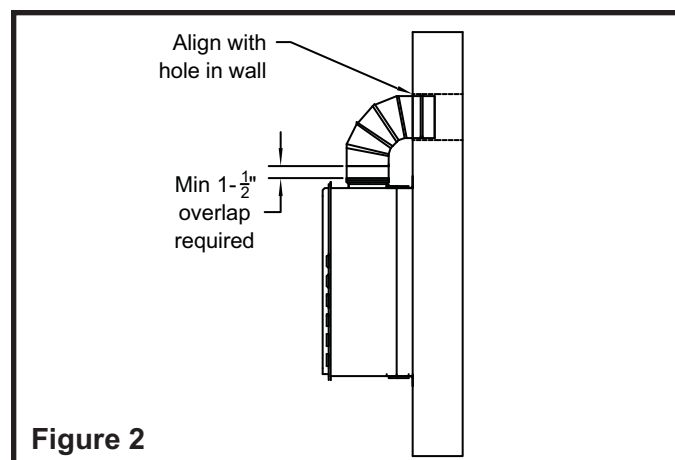

- 11) Moving to the exterior side of the wall, assemble the Horizontal Termination to a short section of Vent Pipe .

Note: For most wall thicknesses, a 12" Vent Pipe Extension (3CG12) is recommended. In the case of a thin wall thickness or wall that does not have an interior surface, a 6" Vent Pipe Extension (3CG6) may be applicable.

The assembled parts will appear as shown in **Figure 3**.

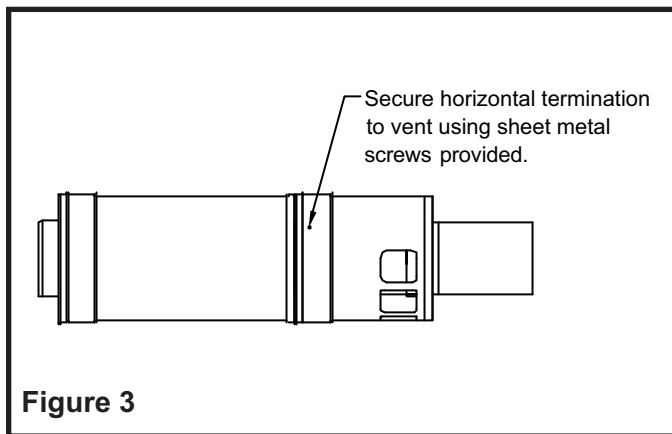

- 12) If the water heater is not securely fastened to the wall, do so now. The water heater should be installed in its final location before proceeding with the next steps to install the vent.

- 13) Assemble the vent pipe section from **Figure 3** into the hole cut in the wall and connect the vent pipe to the Horizontal Adaptor as shown in **Figure 4**.

Note 1: It is recommended to have someone inside the building holding the Horizontal Adaptor steady to counter the force applied in order to join the vent sections.

Note 2: If the installation will be conducted by one person, the installer can opt to assemble all the vent components, insert through the wall opening (from the interior side) and then connect the Horizontal Adaptor onto the water heater outlet collar.

- 14) The Horizontal Termination must be rotated so that the openings are located on the bottom side of the vent (See **Figure 4**). The distance from the openings must be no less than 3" from the exterior surface of the wall.

- 15) Using a general purpose silicone sealant approved for outdoor use, apply an adequate bead of sealant around the vent and exterior of the home (See **Figure 5**). Failure to properly seal this wall penetration will result in long term damage due to weather conditions.

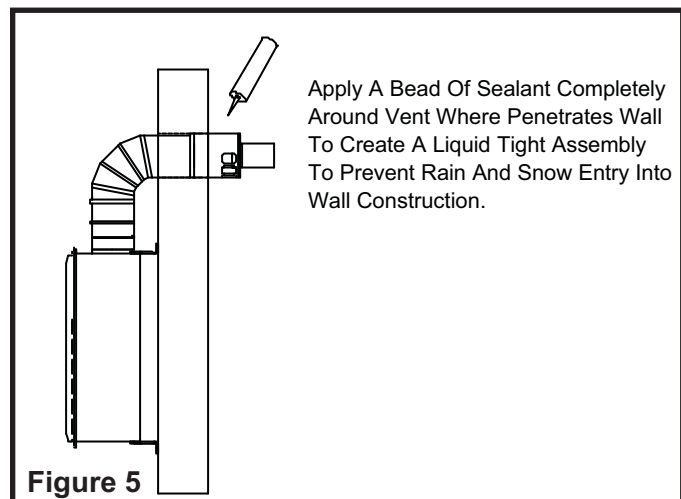
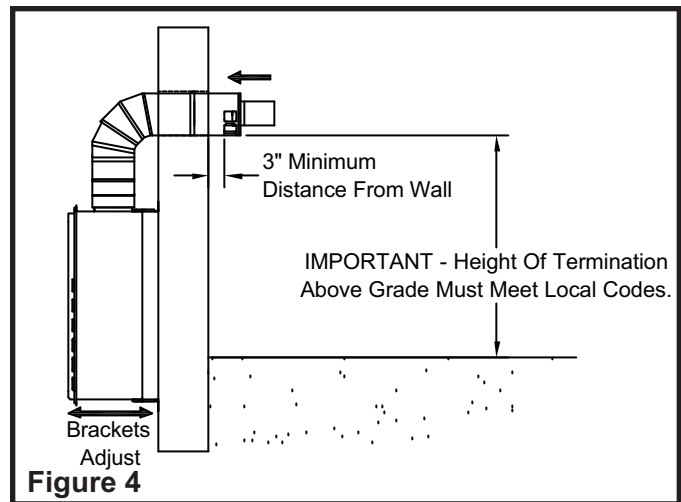

When using the horizontal termination on some types of construction, such as masonry block or stucco, you may want to use the optional horizontal termination ring (part number 3CGTR) to improve the aesthetics of the finished installation. The termination ring can be installed on the exterior of the wall, the interior of the wall, or both.

To Install the 3CGTR: Put a bead of sealant around the inside (bottom) of the termination ring. Slide the termination ring down the vent pipe until it contacts the wall, and press on it with enough force to insure a water tight seal between the termination ring and the wall.

For use on the inside of the structure slip the termination ring on before the termination is installed. For use of the outside of the structure, slip the termination ring on after the horizontal termination has been installed.

- 16) Installation is complete. Refer to tankless water heater instructions for initial operation checks to insure proper operating conditions.

Typical Horizontal Vent Discharge Installation Type B:

Horizontal Vent installation when mounting to interior wall and venting directly out an exterior wall located near the appliance.

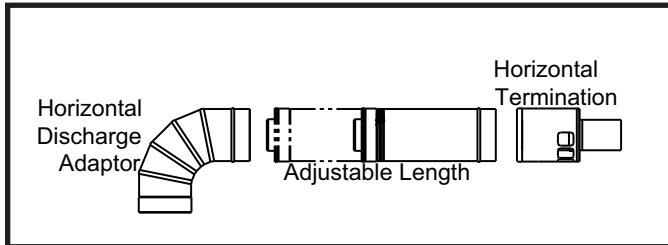

- 1) Connect Horizontal Adaptor to water heater vent outlet. Make sure that rubber seal is seated properly and that the fitting is fully engaged on the water heater. (See **Figure 6**)

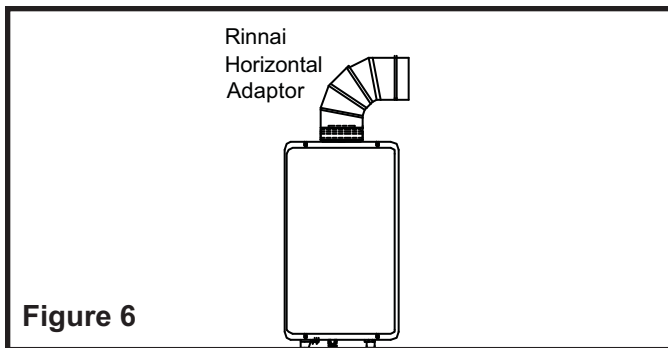

- 2) Turn the Horizontal Adaptor to the right or left of the water heater towards the location where the vent will penetrate the wall. Using a level, run from the top of the Horizontal Adaptor to the location on the outside wall where the vent will penetrate the wall, to mark the top of the vent termination hole. Align the top of the Cut Line on the Wall Discharge Terminal Template (attached at the end of these instructions) with the mark just made. (Tape the template in place temporarily.)
- 3) Using a pencil, or sharp scoring tool, mark the "PILOT HOLE" location by pressing hard enough to penetrate the template leaving a mark on the wall. Remove the template from the wall.
- 4) Using a 1/4" or smaller drill bit (long enough to drill completely through wall), drill a pilot hole from the inside wall surface completely through the outside wall surface.

IMPORTANT: Be certain the drill bit is kept level and straight during the drilling operation.

- 5) Using scissors, carefully cut the Wall Discharge Terminal Template along the outside edge of the dashed circle labeled "CUT LINE" leaving the hatched "Cut Line Template".
- 6) Align the "PILOT HOLE" on the "Cut Line Template" with the pilot hole drilled in the wall and using a pencil, carefully trace a cut line on the inside wall surface, along the edge of the "Cut Line Template". The cut line circle should be 5-5/16" diameter.
- 7) Repeat Step 6 to trace a cut line on the exterior surface of the wall.
- 8) Using a cutting tool suitable for the wall construction (i.e. drill, skill saw, hole saw, etc.), drill or cut the vent termination hole through the wall along the cut lines drawn in Steps 6 and 7.
- 9) Assemble the Adjustable Vent Pipe to the Horizontal Termination. Secure termination to vent pipe using sheet metal screws provided. (See **Figure 7**)

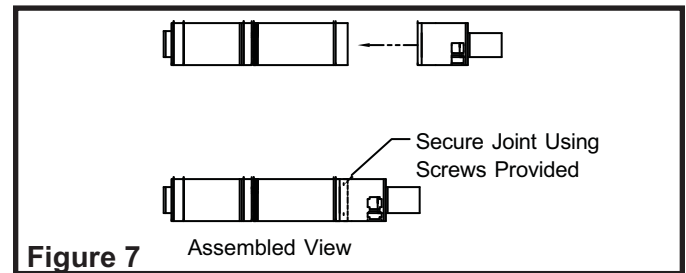

- 10) Then slide the assembly through the hole in the wall (See **Figure 8**). The Horizontal termination should be located so that the opening of the lower side of the termination is a minimum of 3 inch distance away from the wall of the building structure.

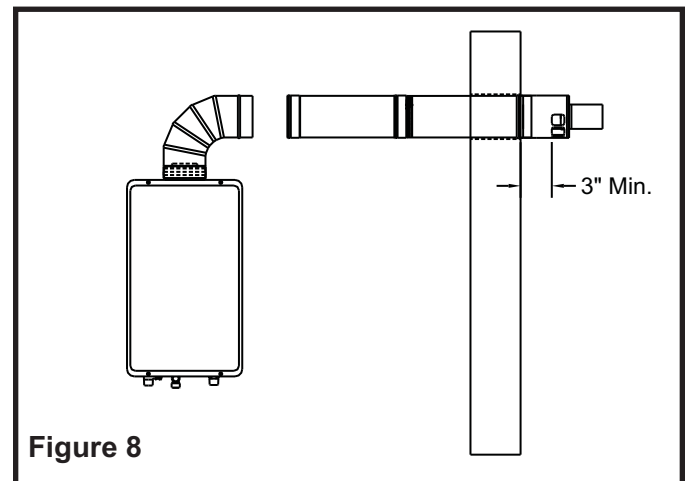

11) The Adjustable Vent Pipe is capable of being stretched or compressed to meet the exact vent length required for proper installation. Simply pull or compress the Adjustable Vent Pipe to the desired length (max 35") and connect to the Horizontal Adaptor. (See **Figure 9**).

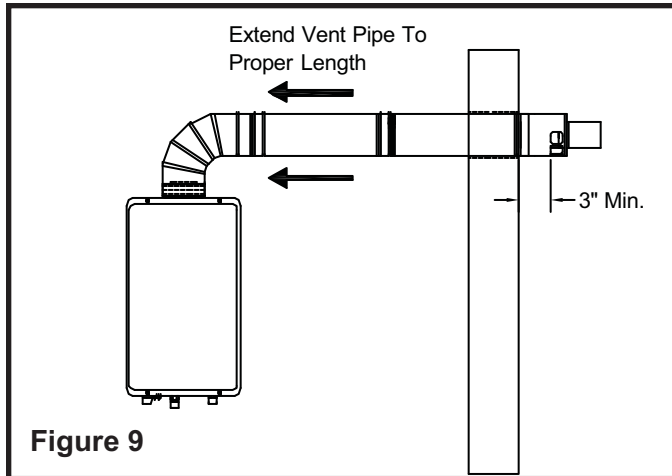

12) Now that all the vent pipes are connected, verify that the Adjustable Vent Pipe is at the appropriate length so that the opening of the lower side of the termination is a minimum of 3 inch distance away from the wall of the building structure.

13) Using a screw driver or nut driver, firmly tighten the compression band on the Adjustable Vent Pipe to prevent the pipe from changing length during future use. (See **Figure 10**).

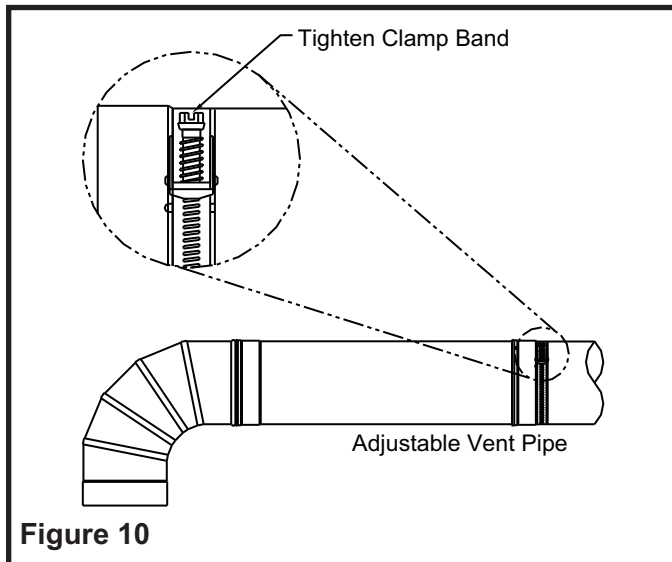

14) If the water heater is not securely fastened to the wall, do so now. The water heater should be installed in its final location before proceeding with the next steps to install the vent.

15) The vent is now ready for final steps of installation. Move outside to view the exhaust termination. (Note: The opening of the lower side of the termination should be a minimum of 3 inch distance away from the wall of the building structure.)

16) Using a general purpose silicone sealant approved for outdoor use, apply an adequate bead of sealant around the vent and exterior of the home. (See **Figure 11**). Failure to properly seal this wall penetration will result in long term damage due to weather conditions.

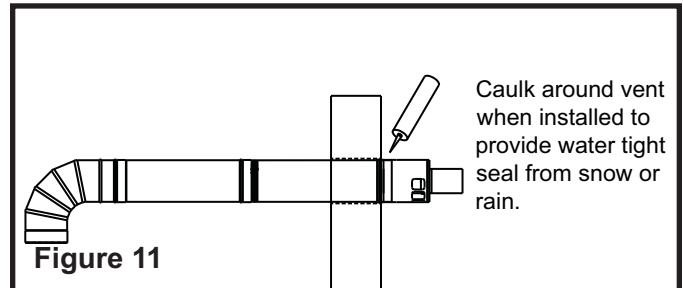

17) Installation is complete. Refer to tankless water heater instructions for initial operation checks to insure proper operating conditions.

Non-Standard Installations Using Miscellaneous Vent Components

Horizontal Venting with Extensions and Wall Termination:

When venting out an exterior wall, some distance away from the water heater:

- 1) Determine the location that the Horizontal Termination will be installed. **IMPORTANT: Vent must slope 1/4" per foot of horizontal vent length. Slope vent down towards wall or provide a Drain Section if sloped towards water heater.**
- 2) Using the template provided with this installation manual, center the hole cut pattern of the template onto the center of the location of where the vent will penetrate the wall. Temporarily tape the template to the wall.
- 3) Using a pencil, or sharp scoring tool, mark the "PILOT HOLE" location by pressing hard enough to penetrate the template leaving a mark on the wall. Remove the template from the wall.

- Using a ¼" or smaller drill bit (long enough to drill completely through wall), drill a pilot hole from the inside wall surface completely through the outside wall surface.

IMPORTANT: Be certain the drill bit is kept level and straight during the drilling operation.

- Using scissors, carefully cut the Wall Discharge Terminal Template along the outside edge of the dashed circle labeled "CUT LINE" leaving the hatched "Cut Line Template".
- Align the "PILOT HOLE" on the "Cut Line Template" with the pilot hole drilled in the wall and using a pencil, carefully trace a cut line on the inside wall surface, along the edge of the "Cut Line Template". The cut line circle should be 5-5/16" in diameter.
- Repeat Step 6 to trace a cut line on the exterior surface of the wall.
- Using a cutting tool suitable for the wall construction (i.e. drill, skill saw, hole saw, etc.), drill or cut the vent termination hole through the wall along the cut lines drawn in Steps 6 and 7.
- Connect the Horizontal or Vertical Adaptor (whichever is appropriate for your installation) to the water heater vent outlet. Make sure that the rubber seal on the inner duct is seated properly and that the fitting is fully engaged on the water heater.
- Continuing from the appliance adaptor, and working toward the Horizontal Termination, connect all of the other venting system components. Make sure that the rubber seal for each joint is seated properly and that each vent joint is fully engaged. **IMPORTANT:** For lateral routing of vent system, the maximum distance between supports must be every 7 feet or less. Use Wall Hangers or plumber's strap to provide support.
- Route vent pipe through the hole cut into the wall in Step 8. For precise location of the Wall Termination, an Adjustable Vent Pipe may be required to establish proper vent pipe length to reduce the amount of vent extruding from the exterior wall.
- Once vent pipe is assembled and penetrating the wall, install the Wall Termination and secure the termination to the vent using the sheet metal screws provided.

- The opening of the lower side of the termination should be a minimum of 3 inch distance away from the wall of the building structure (See **Figure 12**). If applicable, the Adjustable Vent Pipe is capable of being stretched or compressed to meet the exact vent length required for proper installation. Simply pull or compress the Adjustable Vent Pipe to the desired length to provide the minimum distance the vent can terminate from the wall.

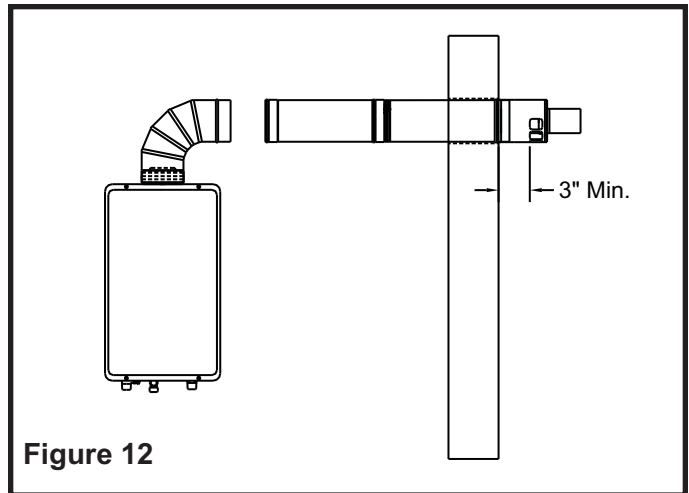

- If applicable, using a screw driver or nut driver, firmly tighten the compression band on the Adjustable Vent Pipe to prevent the pipe from changing length during future use.
- If the water heater is not securely fastened to the wall, do so now. The water heater should be installed in its final location before proceeding with the next steps to install the vent.
- The vent is now ready for final steps of installation. Move outside to view the exhaust termination. (Note: The opening of the lower side of the termination should be a minimum of 3 inch distance away from the wall of the building structure.)
- Using a general purpose silicone sealant approved for outdoor use, apply an adequate bead of sealant around the vent and exterior of the home. Failure to properly seal this wall penetration will result in long term damage due to weather conditions.

Installation is complete. Refer to tankless water heater instructions for initial operation checks to insure proper operating conditions.

Vertical Venting with Extensions and Vertical Termination:

When venting vertically through a roof above the water heater:

- 1) Determine the location that the vent will terminate through the roof.
- 2) Using a cutting tool suitable for the roof construction, cut a hole through the roof decking a suitable size for the Roof Flashing being used. (6" x 6" hole for flat roof, 9" x 6" for 12/12 pitch, or 12" x 6" hole for 16/12 pitch).
- 3) Install the Roof Flashing using suitable fasteners for the roof decking (See **Figure 13**).

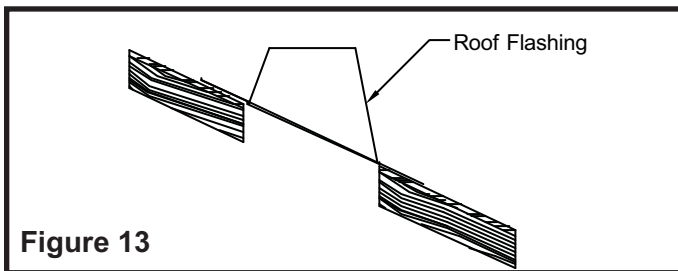

Figure 13

- 4) Begin assembly of venting system at the water heater outlet collar. Connect the Horizontal or Vertical Adaptor (whichever is appropriate for your installation) to the water heater vent outlet. Make sure that the rubber seal is seated properly and that the fitting is fully engaged on the water heater.
- 5) For all vertically vented installations, a drain section located near the water heater vent outlet is required. Connect a Vertical Drain Section or Horizontal Drain Section (whichever is appropriate for your installation) to the adaptor installed in Step 4.
- 6) Continue to connect vent sections and fittings as appropriate for the installation. Vent must be installed so that male end of the vent is directed towards the vertical termination (label on vent pipe pointed towards the roof). This allows for proper draining of condensed vapor as the water heater is operating. Each joint is secured using sheet metal screws provided (See **Figure 14**).

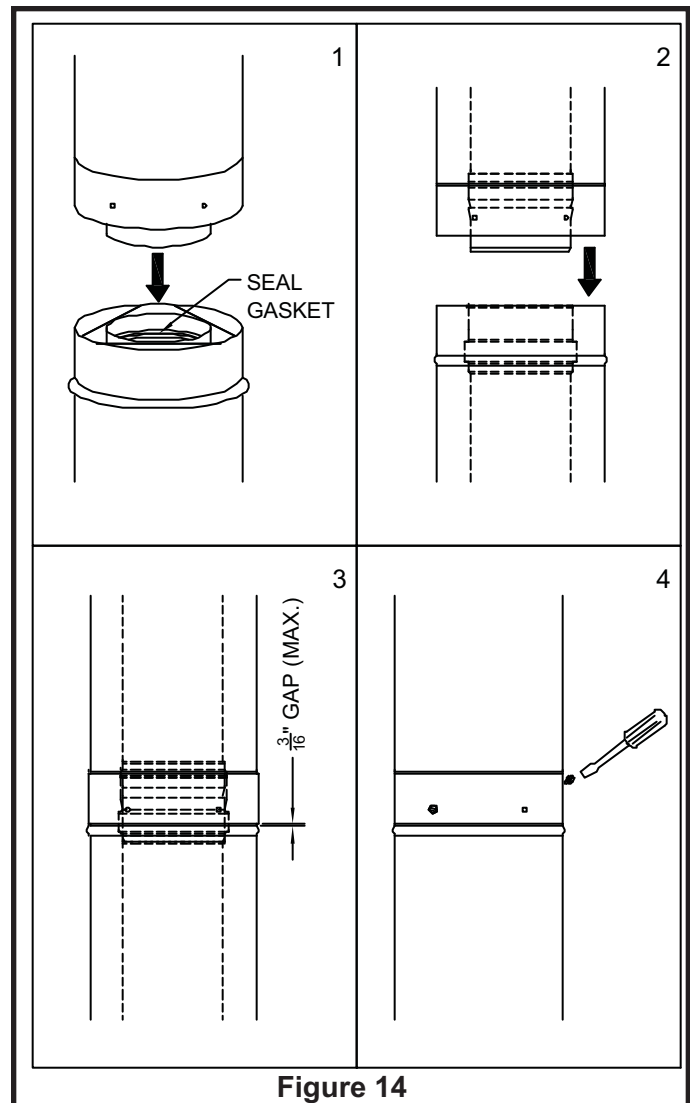

Figure 14

- 7) Vertical supports are to be used after each transition to vertical and for the remaining vertical vent up to the roof. Vertical support is required after every offset elbow to prevent vertical loading on offsets. Upon penetrating a floor ceiling, install a vertical support which can also serve as a firestop. Support can be provided by using a Vertical Plate Support (which will also serve as a firestop and will support up to 30' of vertical vent) or use of Wall Hangers or plumber's strap at every 7' or less is acceptable.
- 8) If special vent length is required between offsets or changes in vent direction, install an Adjustable Vent Pipe and set to proper vent length for the installation (See **Figure 10** on **Page 8**).
- 9) Continue installing vent sections up and through the Roof Flashing installed earlier. The vent will easily slide through the opening of the flashing. The vent pipe must extend a minimum of 6 inches past the top of Roof Flashing (See **Figure 15**).

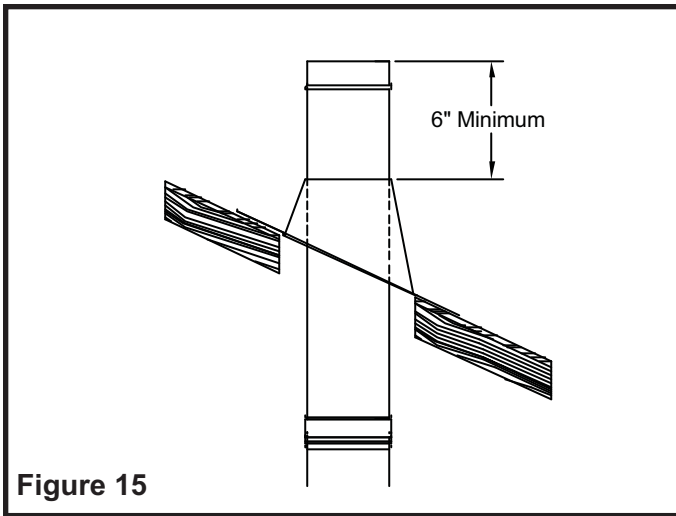

Figure 15

10) Once all the vent sections (not including the Vertical Termination) have been installed and all supports are securely fashioned, the Storm Collar must be installed over the Roof Flashing and adequately sealed to prevent rain entry. Use of MST Tape or a weather resistant silicon sealant (or equivalent) is required. Install the Storm Collar tightly over the vent pipe and press securely onto the Roof Flashing and apply a water tight seal (See **Figure 16**).

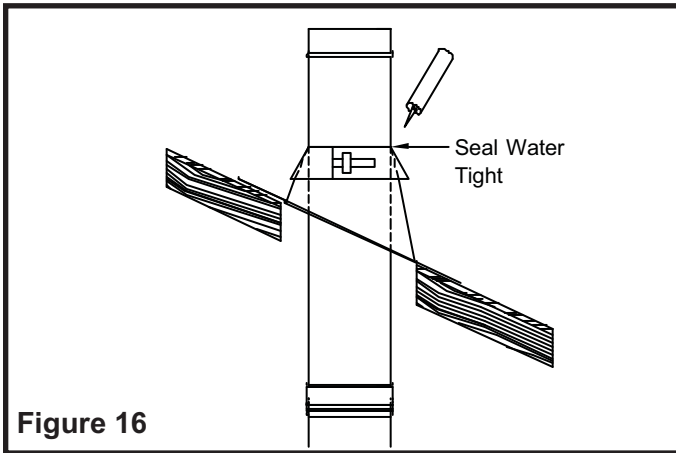

Figure 16

- 11) After the storm collar is installed, connect the Vertical Termination onto the vent pipe exiting the roof. Secure the joint with sheet metal screws provided. Properly installed, the top of the Vertical Termination should not be less than 18 inches from the storm collar below (See **Figure 17**). **IMPORTANT: Vent pipe should not extend more than 5' from roof unless additional guy wires or other additional support is provided.**
- 12) Seal all exterior gaps and seams of the pipe and flashing assembly using MST Tape or silicon sealant.

Installation is complete. Refer to tankless water heater instructions for initial operation checks to insure proper operating conditions.

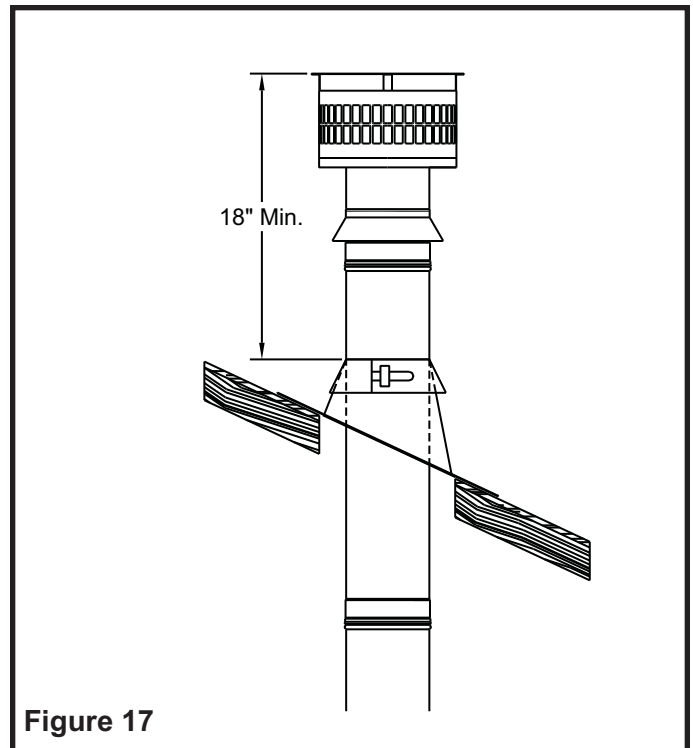

Figure 17

Refer to last page for Wall Discharge Terminal Template.



8 0 0 - 8 3 5 - 2 8 3 0

P.O. Box 1138 • WICHITA, KANSAS 67201

(316) 943-2351 • FAX (316) 943-2717

info@metal-fabinc.com • www.metal-fabinc.com

©2007 Metal-Fab, Inc.

Form No. L2408

12/07
8190

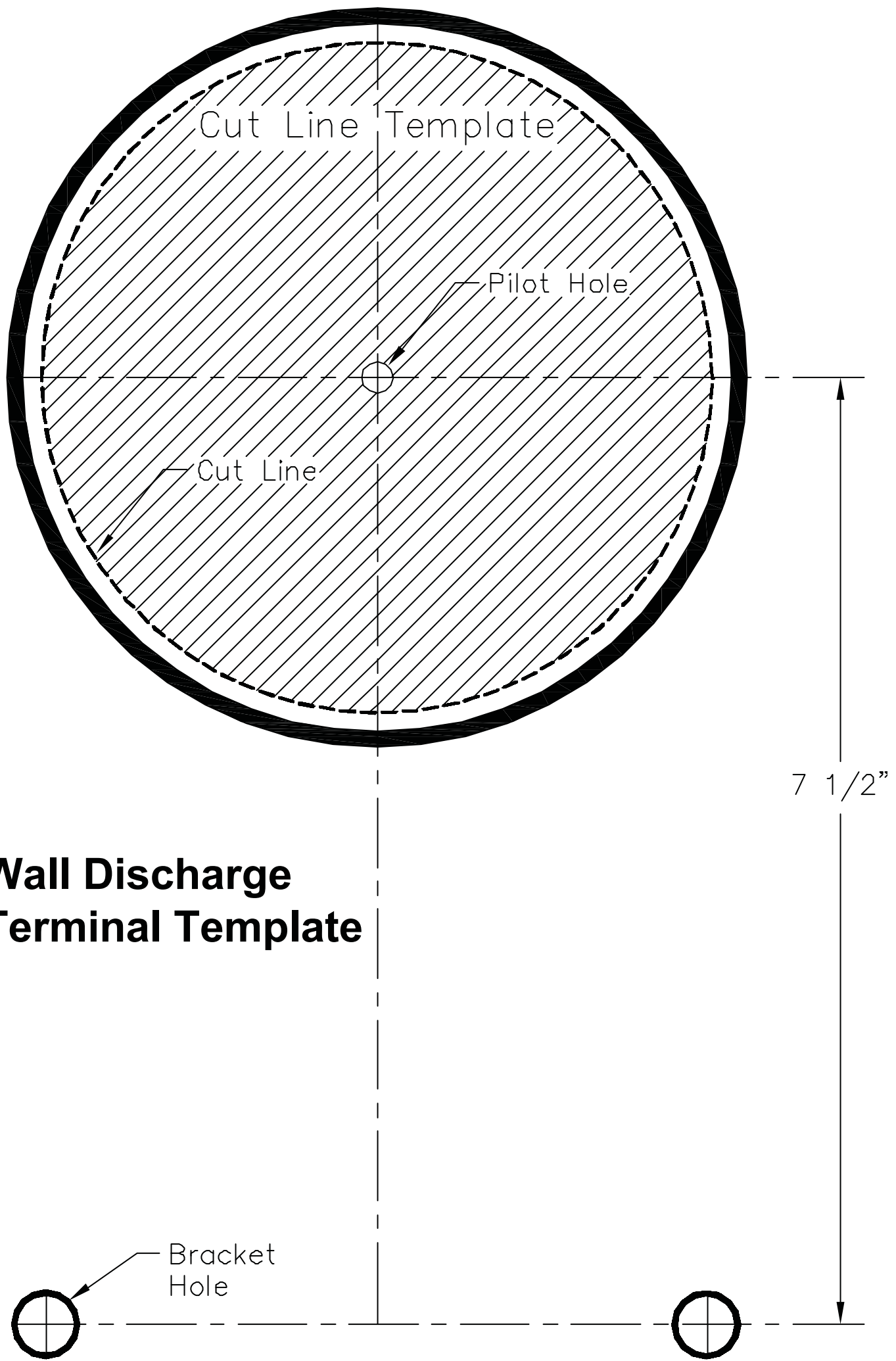

Cut Line Template

Pilot Hole

Cut Line

$7 \frac{1}{2}$ "

**Wall Discharge
Terminal Template**

Bracket
Hole

