



INSTALLATION AND MAINTENANCE INSTRUCTIONS

MODELS - ATG (AIR-COOLED) & INTG (INSULATED) CHIMNEY

**1700°F Air-Cooled & Insulated
Temp/Guard Chimney Sizes 8"-16"**



Listing No. MH8251
Tested to UL103/ULC-S604

A MAJOR CAUSE OF CHIMNEY RELATED FIRES IS FAILURE TO MAINTAIN REQUIRED CLEARANCE (AIR SPACES) TO COMBUSTIBLE MATERIAL*. MINIMUM CLEARANCE FOR 8" - 16" DIAMETER AIR-COOLED AND INSULATED TEMP/GUARD CHIMNEY IS TWO (2) INCHES. IT IS OF UTMOST IMPORTANCE THAT THIS CHIMNEY IS INSTALLED ONLY IN ACCORDANCE WITH THESE INSTRUCTIONS.

*Combustible material is defined as material made of, or surfaced with, wood, compressed paper, plant fibers, plastic, or other material that will ignite and burn, whether flame proofed or not, or plastered or not plastered.

The Metal-Fab models ATG, Air-Cooled Temp/Guard Chimney and INTG, Insulated Temp/Guard are intended for use on masonry fireplaces or building heating appliances burning gas, liquid or solid fuels. Do not use with forced draft or positive-pressure appliances. The Temp/Guard Air-Cooled system is designed to extend vertically with a maximum of two (2) offset (four elbows total) up to 30° from vertical for 8"-14" diameters and up to 15° from vertical for 16" diameter. Contact Local Building or Fire Officials about restrictions and installation inspection in your area. These instructions must be followed in all details and failure to do so may result in a hazardous installation.

[WARNING: If decorative shrouds are being used with ATG & INTG chimney, reference the Temp/Guard addendum - L2372.]

OPERATIONAL PRECAUTIONS & MAINTENANCE:

Metal-Fab Air-Cooled and Insulated Temp/Guard Chimney is not designed for use on products that operate at continuous temperatures in excess of 1000°F. "Keep these instructions for future use."

[WARNING: DO NOT MIX ATG (Air-Cooled) and INTG (Insulated) chimney components.]

Creosote and Soot – Formation and Need for Removal:

When wood is burned slowly, it produces tar and other organic vapors, which combine with expelled moisture to create creosote. The creosote vapors condense in the relatively cool chimney flue of the slow burning fire. As a result, creosote residue accumulates on the flue lining. When ignited, the creosote makes an extremely hot fire. The chimney should be inspected at least once every two (2) months during the heating season to determine if a creosote or soot buildup has occurred. If creosote or soot has accumulated, it should be removed to reduce the risk of chimney fire.

Chimneys must be installed so that access is provided for inspection and cleaning.

Never fill any required clearance space with insulation or any other building materials surrounding the chimney.

Do not use a fireplace for food grilling. Grease from foods can collect in chimney causing fireplace to become a potential fire hazard.

Some chemical Chimney cleaners can be harmful to the chimney. These cause accelerated oxidation or corrosion. If chemical cleaners are used, they must be non-corrosive in nature. If a brush is used, it must be of proper size with plastic bristles. Have your chimney cleaned by a professional certified chimney sweep.

If a flue fire occurs, close all possible air inlets, and call your Fire Department. Do not use the chimney again until it has been inspected by a Certified Chimney Sweep for possible damage.

Exterior metal parts, with exception of the top portion of the chimney cap, can be painted with a high temperature rust proof paint. Wash the metal surface with a vinegar and water solution to remove any residue before painting. Painting the chimney will help to increase chimney life.

Metal-Fab assumes no liability for structural damage or roof contamination as the result of creosote formation. It is the owner's responsibility to comply with inspection and cleaning requirements as described in these instructions, and those of the appliance manufacturer.

CHIMNEY DIAMETER:

Follow the fireplace manufacturer's manual to determine required chimney diameter and clearances between combustible materials and your fireplace. Never use a chimney with an inside diameter smaller than your firebox flue opening unless specifically allowed by the fireplace manufacturer. If connecting to a masonry fireplace refer to Metal-Fab literature L1372 or **FIG. 14** for proper sizing.

CHIMNEY ENCLOSURE REQUIREMENTS:

Interior chimneys shall be enclosed where they extend through closets, storage areas, occupied spaces, or anywhere the surface of the chimney could be contacted by persons or combustible materials. The air space between the outer wall of the chimney and the enclosure shall not be less than 2 inches.

WARNING: Do not place any type of insulation or other materials in the required clearance spaces surrounding the chimney assembly.

Except for installation in one or two family dwellings, a factory built chimney that extends through any zone above that on which the connected appliance is located is to be provided with an enclosure having a fire resistance rating equal to or greater than that of the floor or roof assemblies through which it passes.

In cold climates, chimneys mounted on an outside wall should be enclosed in a chase. Exterior chases reduce condensation, creosote formation and enhance draft.

Chimney components intended for exterior installation must be marked "**Suitable for Interior or Exterior Installation**".

INSTALLATION RECOMMENDATIONS:

Proper planning for your Metal-Fab ATG & INTG chimney installation will result in greater safety, efficiency and convenience. You must use only Metal-Fab parts and components to maintain a listed chimney system. Do not mix parts or try to match with other products or use improvised solutions.

Install your fireplace as described by the manufacturer's installation instructions and maintain all required clearances. Acceptance of the assembly is void if the installation instructions are not followed.

Connect only one fireplace per chimney. Follow the fireplace safety manual for maximum efficiency and safety. Do not over fire. Any damage to the fireplace or chimney can possibly void the warranty.

Do not burn driftwood, plastic, or chemically treated wood such as railroad ties. They are corrosive to your chimney system. Follow the fireplace manufacturer's instructions regarding fuel.

MASONRY FIREPLACE INSTALLATION:

Place Fireplace: Position according to the fireplace manufacturer's installation instructions. The flue outlet should be placed between the rafters or joists above, if possible.

Determine Chimney Size: Follow the fireplace manufacturer's instructions for chimney size or use Metal-Fab literature L1372 or **FIG. 14** to determine the correct diameter chimney for your fireplace.

Mount Anchor Plate: Chimneys for masonry fireplaces begin with an Anchor Plate or Anchor Plate with Damper.

Warning: *Anchor Plate with Damper is not allowed in chimneys serving stoker-fired, liquid or gas burning appliances.*

Caution: *Do not install Anchor Plate with Damper on Factory Built Fireplaces.*

Caution: *Anchor Plate with Damper is intended for use with masonry fireplaces.*

It is important that the surface of the masonry chimney has a level surface on which to attach the Anchor Plate. If the top of the masonry does not have a level surface, then it will need to be modified accordingly. Center the Anchor Plate over the masonry flue opening. If a Damper is used, make sure nothing interferes with the damper plate movement. Seal the Anchor Plate in place with a high temperature sealant. Secure the Anchor Plate with four (4) masonry anchors. See **FIG. 1**. If the Anchor Plate with Damper is installed the damper should swing freely. When the chain is pulled down, the damper should close (horizontal position). When the chain is released (no weight on the chain), the damper should swing open (vertical position). To install the lintel hook, place the damper plate in the closed (horizontal) position. Determine and mark the position of the lintel hook. The lintel hook should be mounted in a position so as to provide a small amount of tension in the spring attached to the chain. See **FIG. 1**. The tension is needed to prevent the damper plate from rattling when closed. Mount the lintel hook to masonry with the screws provided. Do not obstruct oval openings in the anchor plate.

Warning: *Do not locate Anchor Plate with Damper in a location inaccessible for inspection, cleaning and servicing after installation.*

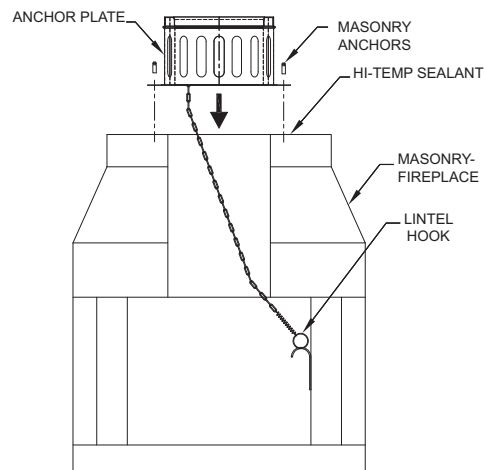

FIG. 1

Attach Chimney: Attach the first section of chimney on the Anchor Plate. The joint assembly is a male to female slip fit and held together with (4) sheet metal screws provided. See **FIG 2**. Do not penetrate the inner liner of the chimney when installing screws. Maintain a 2 inch clearance to combustibles. Do not fill the clearance space with any materials. If an offset is required, refer to Elbow Offset Installation Section.

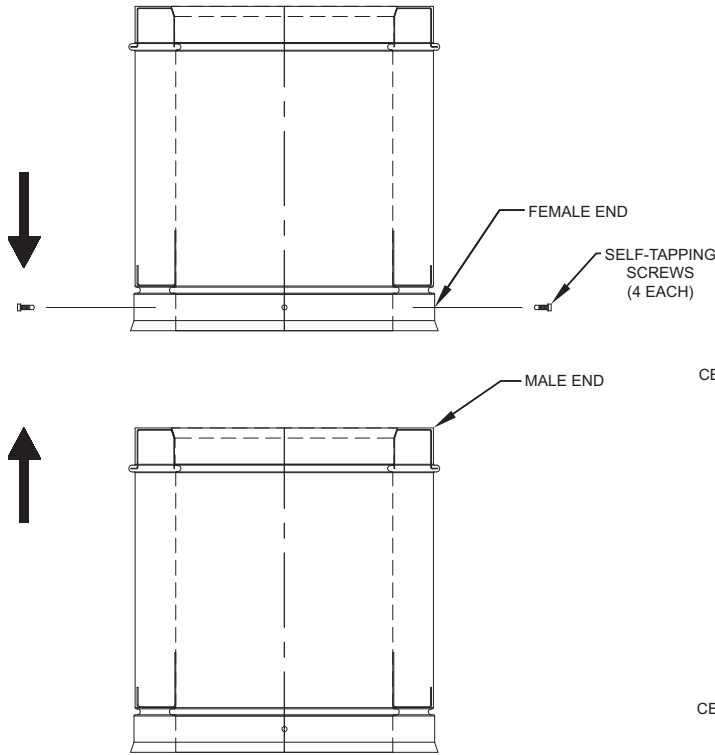

FIG. 2

Frame Openings: From the ceiling, drop a plumb bob to the center of the fireplace's flue outlet and mark the center point on the ceiling. Refer to **TABLE 1** for the framing dimensions.

Frame Opening Dimensions	
Diameter	Framing Dimensions
8"	15" X 15"
10"	17" X 17"
12"	19" X 19"
14"	21" X 21"
16"	23" X 23"

TABLE 1

Mark appropriate cutting lines around the center point. Cut a square hole in the ceiling. Frame a level, square opening centered over the hole that you have cut. Frame openings at each floor level above the fireplace. See **FIG. 3**. These openings are to hold the Firestop and Attic Insulation Shield. Locate each opening by dropping a plumb bob to the four corners of the opening below. Maintain the 2 inch airspace to combustibles. See **FIG. 4**.

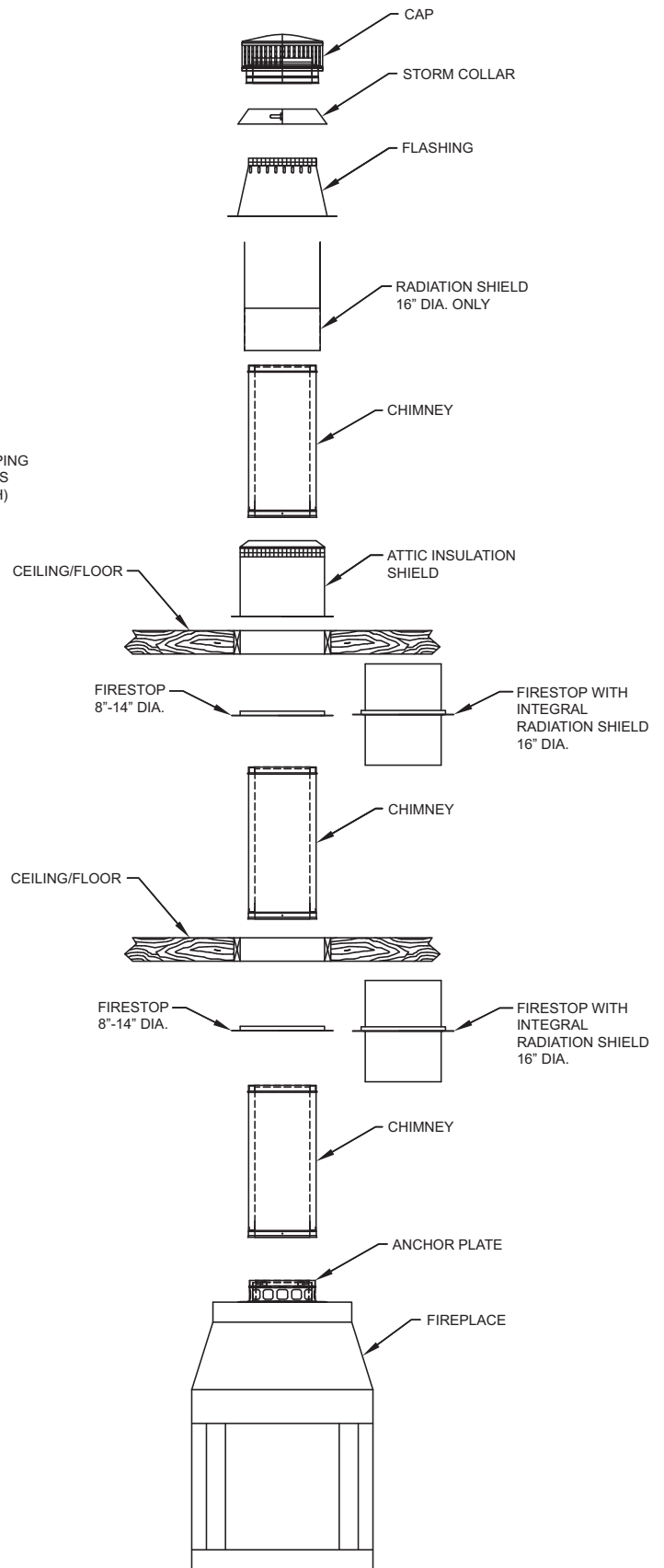

FIG. 3

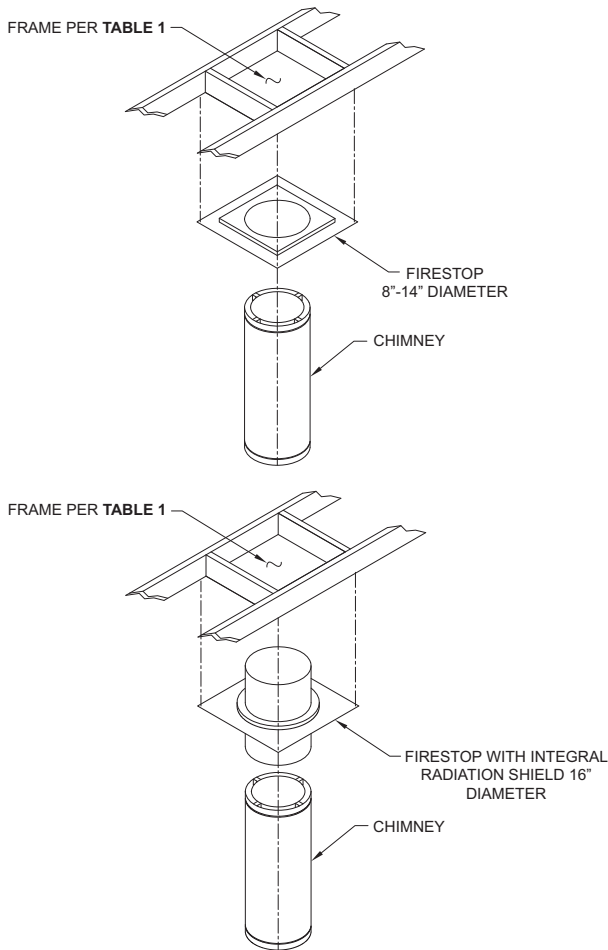

FIG. 4

Cut Roof Opening: If penetrating through the roof, determine and cut an opening in the roof directly above the opening below. The cut opening must be 4 inches larger than the chimney's outside diameter to provide at least a 2 inch clearance all around the chimney. The chimney must be centered in this opening.

Install Firestop: A Firestop is required on each floor penetration in multistory installations. Building Codes require a Firestop at every floor/ceiling level including where the chimney penetrates the attic. FIG. 3 shows a typical 2 story installation with an attic.

NOTE: A Firestop is not installed where the chimney penetrates through the roof. The Firestop is installed on the underside of the ceiling/floor framing and secure in place with nails or screws.

NOTE: The Firestop for 16" diameter has an integral radiation shield and does not allow for a reduced clearance to combustibles.

Angle Support and Support Band: Install an Angle Support if total chimney height is greater than 50 feet, or if the fireplace manufacturer requires it. If additional support is needed, install one or more Angle Supports which will support 30 feet of chimney. See FIG. 5. Slide the Angle Support around the chimney and align over framed opening. Secure to casing with (4) sheet metal screws and assemble brackets per FIG. 6.

Nail the brackets to the framing using a minimum of (2) nails or screws per bracket. A Support Band may be required by some fireplace manufacturers to keep the chimney vertical and help maintain clearances to combustibles within a chase. Clamp the Support Band to the pipe using the nut and bolt provided and secure legs to nearby framing using plumbers strap or guy wires. See FIG 7. The Support Band does not support the weight of the chimney, it is only used to keep the chimney centered within a chase.

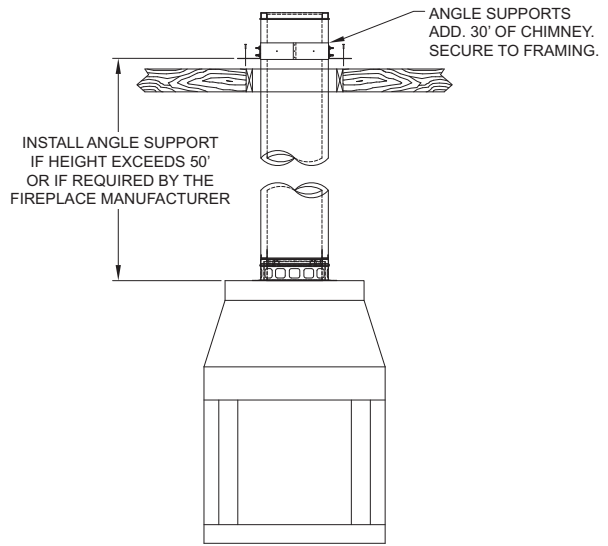

FIG. 5

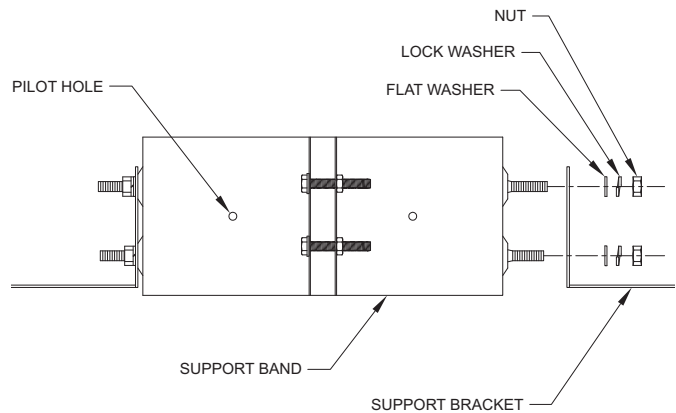

FIG. 6

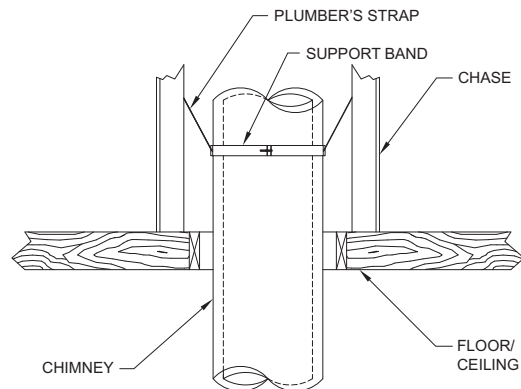

FIG. 7

Attic Insulation Shield: The Attic Insulation Shield must be installed where the chimney passes into an attic. Its purpose is to maintain clearances from loose packed or blown insulation from the chimney. If an Attic Shield is not used the chimney needs to be enclosed within a framed enclosure. Always maintain a 2" air-space clearance to combustibles. Install the shield as follows:

- Remove any insulation or debris from attic floor around the framed opening.
- Assemble chimney sections above the Firestop to a height that extends beyond the height of the attic insulation shield.
- Slip the Attic Insulation Shield over the chimney until the base sits squarely on the framed opening.
- Secure the Attic Insulation Shield to the top of the framed opening using nails or screws. See FIG. 8.

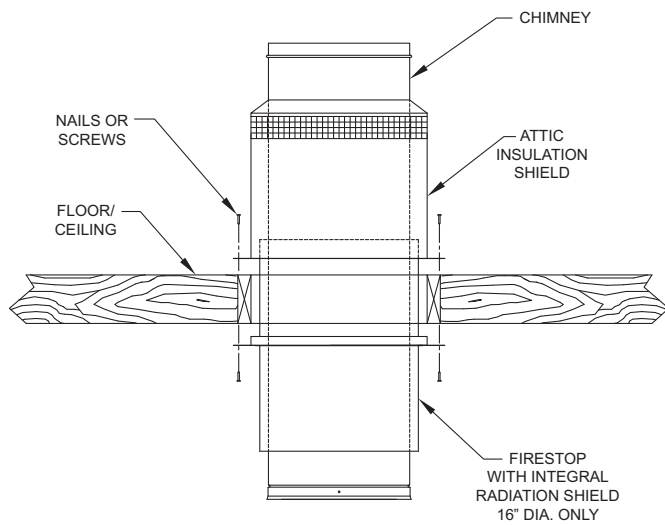

FIG. 8

Termination: NFPA 211, "Standard for Chimneys, Fireplaces, Vents, and Solid Fuel-Burning Appliances", states that chimneys shall extend at least three feet above the highest point where it passes through the roof of a building, and at least two feet higher than any portion of a building within ten feet. See FIG. 9.

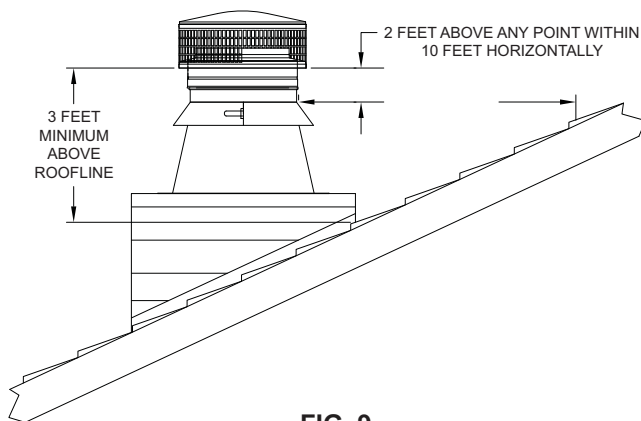

FIG. 9

For chase enclosures, install the chase top cover (supplied by others) to the chase enclosure. Cut a hole in the chase top cover the same diameter as the base of the cone on the flashing. Slide the Radiation Shield (16" diameter ONLY) over the chimney. The tabs of the Radiation Shield go through the center of the flashing and wrap around the top of the flashing. Secure the tabs to the flashing with sheet metal screws when aligned within the flashing and below the top cover plate. Attach the Flashing to the top of the chase cover, sealing with a non-hardening waterproof sealant. Secure in place with screws or rivets. See FIG. 10.

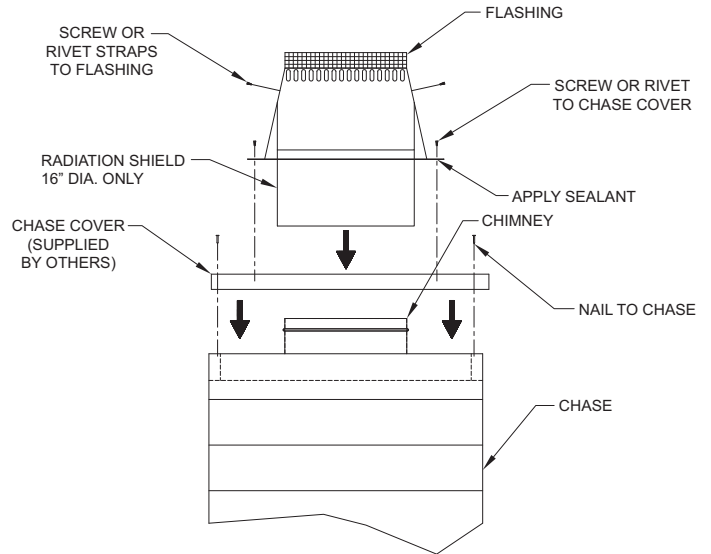

FIG. 10

Attach the storm collar around the chimney above the screen of the flashing. Secure in place with the locking tab and button. Seal around the storm collar with a non-hardening waterproof sealant. Attach the Termination Cap to the chimney by sliding the male to female joint connection together and secure in place with (4) sheet metal screws provided. See FIG. 11.

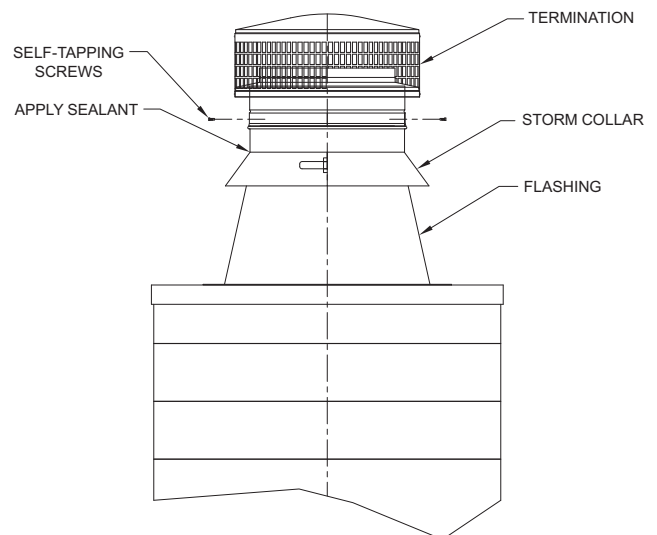

FIG. 11

Elbow Installation: 15° and 30° elbows are provided to allow chimneys to avoid framing members or roof peaks. A maximum of 30° from vertical is allowed and a total of four 30° elbows for 8" - 14" diameters (**FIG. 12A**) and four 15° elbows for 16" diameter (**FIG. 12B & 12C**) or two 30° elbows per each chimney installation. A 2" clearance to combustibles must be maintained.

Attach the elbow to the chimney pipe, support or other part. Using the offset chart, add chimney sections between elbows. A Support Band or plumbers strap is required for every 4 foot interval between elbows to support the load as shown in **FIG. 12A**, **FIG. 12B & 12C**. Attach the upper elbow to bring the chimney back to vertical. See **TABLE 2** and **FIG. 13** for offset combinations.

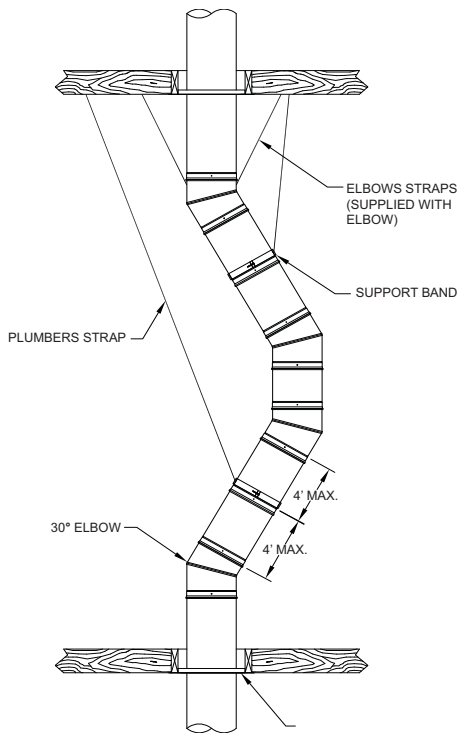

FIG. 12A (8"-14" Diameters)

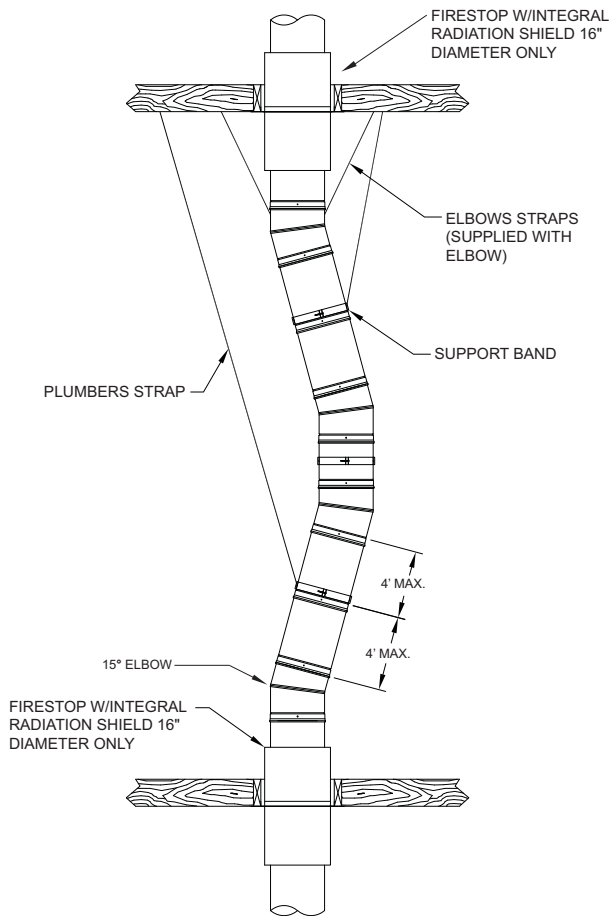

FIG. 12B (16" Diameter)

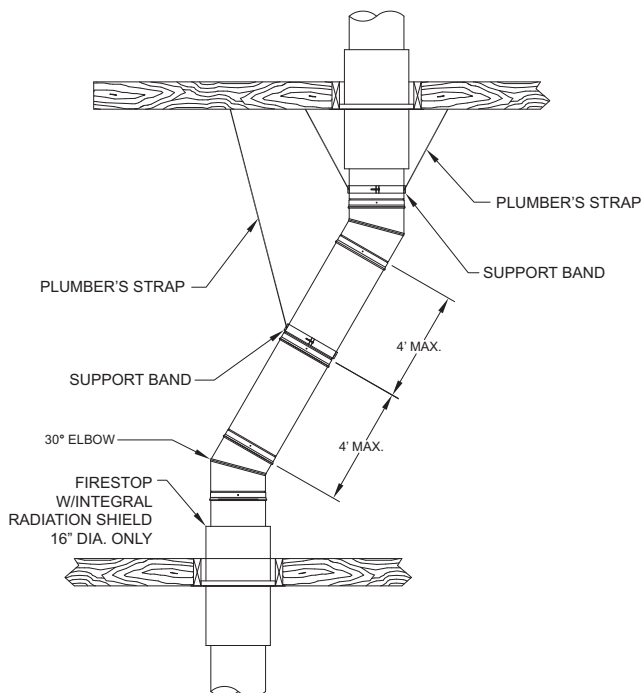

FIG. 12C (16" Diameter)

ELBOW OFFSET CHART

Elbow Angle	Length "A"	8" Diameter		10" Diameter		12" Diameter		14" Diameter		16" Diameter	
		"B"	"C"	"B"	"C"	"B"	"C"	"B"	"C"	"B"	"C"
15°	0"	19-1/4"	2-3/8"	19-3/4"	2-1/2"	20-1/4"	2-1/2"	20-3/4"	2-1/2"	21-1/4"	2-5/8"
	12"	29-1/4"	5"	29-3/4"	5-1/8"	30-3/8"	5-1/4"	30-3/4"	5-1/4"	31-3/8"	5-3/8"
	18"	35"	6-5/8"	35-5/8"	6-3/4"	36-1/8"	6-3/4"	36-5/8"	6-3/4"	37-1/8"	6-7/8"
	24"	40-7/8"	8-1/8"	41-3/8"	8-1/4"	41-7/8"	8-1/4"	42-3/8"	8-3/8"	42-7/8"	8-3/8"
	36"	52-1/2"	11-1/4"	53"	11-3/8"	53-1/2"	11-3/8"	54"	11-1/2"	54-1/2"	11-1/2"
	48"	64"	14-3/8"	64-5/8"	14-1/2"	65"	14-1/2"	65-5/8"	14-5/8"	66"	14-5/8"
	60"	75-7/8"	17-1/2"	76-3/8"	17-5/8"	76-7/8"	17-3/4"	77-1/2"	17-3/4"	78"	17-7/8"
	72"	87-1/2"	20-5/8"	88"	20-3/4"	88-1/2"	20-7/8"	89"	20-7/8"	89-1/2"	21"
	84"	99"	23-3/4"	99-1/2"	23-7/8"	100"	23-7/8"	100-1/2"	24"	101-1/8"	24"
	96"	110-5/8"	26-7/8"	111-1/8"	27"	111-5/8"	27"	112-1/8"	27"	112-5/8"	27-1/8"

Elbow Angle	Length "A"	8" Diameter		10" Diameter		12" Diameter		14" Diameter		16" Diameter	
		"B"	"C"	"B"	"C"	"B"	"C"	"B"	"C"	"B"	"C"
30°	0"	21-1/8"	5-1/4"	22-1/8"	5-5/8"	23-1/8"	5-7/8"	24-1/8"	6-1/8"	25-1/8"	6-3/8"
	12"	30-3/8"	10-5/8"	31-3/8"	10-7/8"	32-3/8"	11-1/8"	33-1/8"	11-3/8"	34-1/8"	11-5/8"
	18"	35-1/2"	13-5/8"	36-1/2"	13-7/8"	37-1/2"	14-1/8"	38-3/8"	14-3/8"	39-3/8"	14-5/8"
	24"	40-3/4"	16-5/8"	41-3/4"	16-7/8"	42-3/4"	17-1/8"	43-1/2"	17-3/8"	44-1/2"	17-5/8"
	36"	51-1/8"	22-5/8"	52-1/8"	22-7/8"	53-1/8"	23-1/8"	53-7/8"	23-3/8"	54-7/8"	23-5/8"
	48"	61-1/2"	28-5/8"	62-1/2"	28-7/8"	63-1/2"	28-1/8"	64-3/8"	29-3/8"	65-3/8"	29-5/8"
	60"	71-7/8"	34-5/8"	72-7/8"	34-7/8"	73-7/8"	35-1/8"	74-7/8"	35-3/8"	75-7/8"	35-3/4"
	72"	82-1/4"	40-5/8"	83-1/4"	40-7/8"	84-1/4"	41-1/8"	85-1/4"	41-3/8"	86-1/4"	41-3/4"
	84"	92-5/8"	46-5/8"	93-5/8"	46-7/8"	94-5/8"	47-1/8"	95-5/8"	47-3/8"	96-5/8"	47-3/4"
	96"	103"	52-5/8"	104"	52-7/8"	105"	53-1/8"	106"	53-3/8"	107"	53-3/4"

TABLE 2

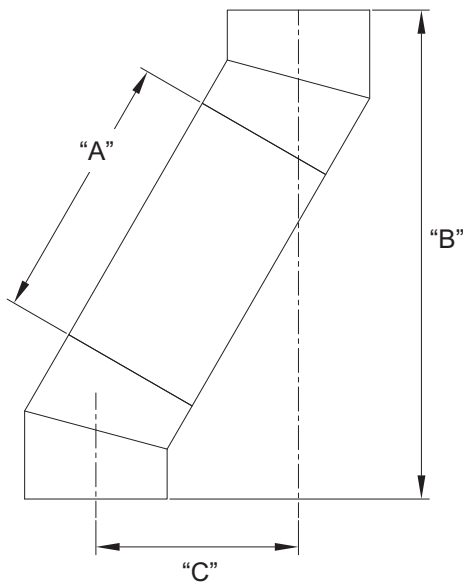
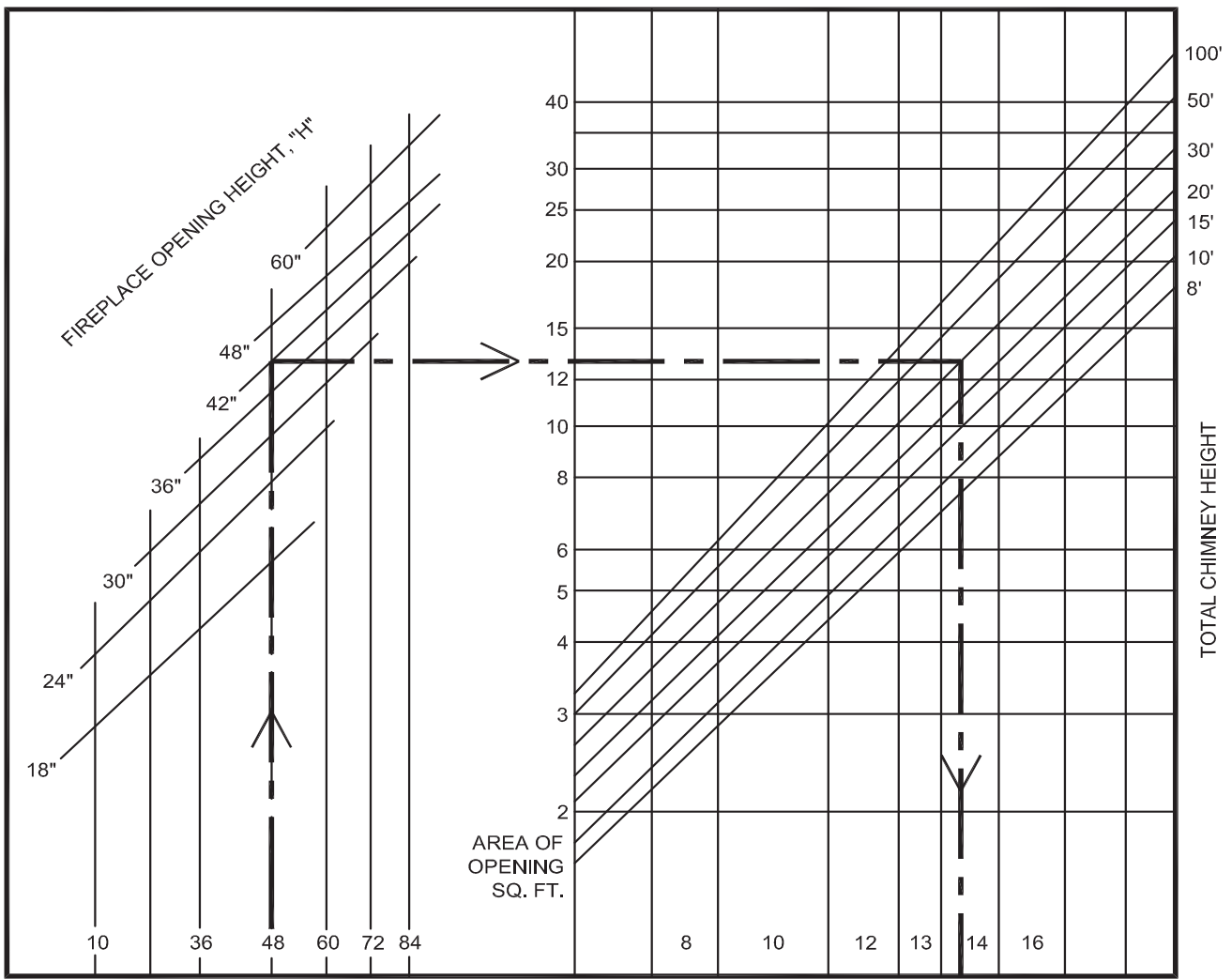

FIG. 13

EXAMPLE: FIREPLACE OPENING 48" WIDTH BY 42" HEIGHT
 CHIMNEY HEIGHT 30' USE 14" DIAMETER



FIREPLACE OPENING WIDTH, "W"

FIG. 14

CHIMNEY SIZE, INCHES DIAMETER

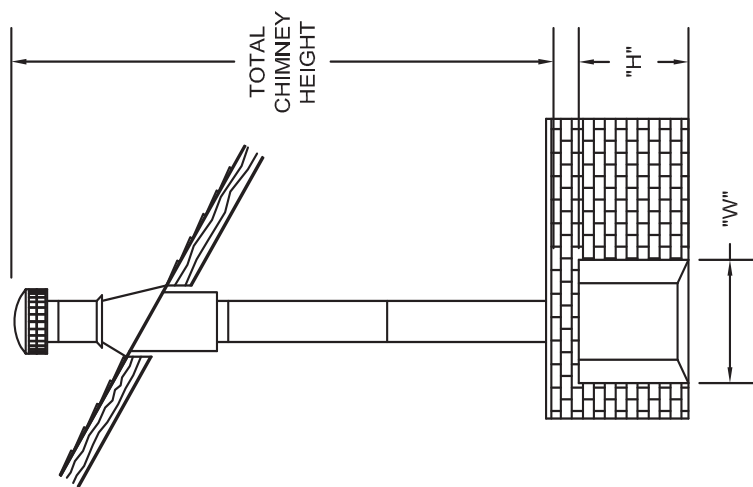

CAUTION: ALWAYS FOLLOW
 MANUFACTURER'S INSTALLATION
 INSTRUCTIONS



P.O. Box 1138 • WICHITA, KS 67201
 (316)943-2351 • Fax (316)943-2717

© 2021 Metal-Fab, Inc. Form No. L2751 02/21
 10128