

Owner's Manual

Care and Operation

CAUTION! Risk of Fire! DO NOT store instruction manuals inside fireplace cavity. High temperatures could cause a fire.

INSTALLER: Leave this manual with the appliance, not inside the appliance.

CONSUMER: Retain this manual for future reference. Do not store inside the appliance

NOTICE: DO NOT discard this manual!



Models:

TRILLIANT25IN
TRILLIANT30IN
TRILLIANT35IN
→ TRILLIANT25IL
TRILLIANT30IL
TRILLIANT35IL

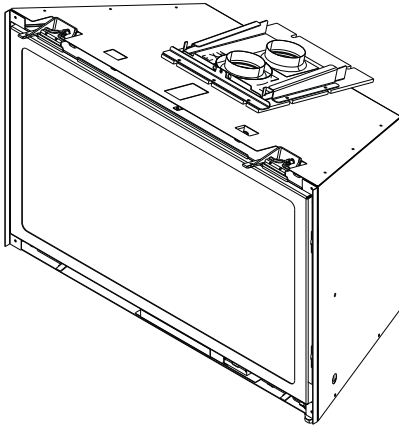

This appliance may be installed as an OEM installation in manufactured home (USA only) or mobile home and must be installed in accordance with the manufacturer's instructions and the *Manufactured Home Construction and Safety Standard, Title 24 CFR, Part 3280* in the United States, or the *Standard for Installation in Mobile Homes, CAN/CSA Z240 MH Series*, in Canada.

This appliance is only for use with the type(s) of gas indicated on the rating plate. This appliance is not convertible for use with other gases, unless a certified kit is used.

▲ WARNING:

FIRE OR EXPLOSION HAZARD

Failure to follow safety warnings exactly could result in serious injury, death, or property damage.

- **DO NOT** store or use gasoline or other flammable vapors and liquids in the vicinity of this or any other appliance.
- **What to do if you smell gas**
 - **DO NOT** try to light any appliance.
 - **DO NOT** touch any electrical switch. **DO NOT** use any phone in your building.
 - Leave the building immediately.
 - Immediately call your gas supplier from a neighbor's phone. Follow the gas supplier's instructions.
 - If you cannot reach your gas supplier, call the fire department.
- Installation and service must be performed by a qualified installer, service agency, or the gas supplier.

! DANGER



HOT GLASS WILL CAUSE BURNS.

DO NOT TOUCH GLASS UNTIL COOLED.

NEVER ALLOW CHILDREN TO TOUCH GLASS.

A barrier designed to reduce the risk of burns from the hot viewing glass is provided with this appliance and must be installed for the protection of children and other at-risk individuals.

Pour demander un exemplaire en français de ce Manuel du propriétaire, visitez www.majesticproducts.com.

1 Welcome

Read this manual before operating this appliance.
Please retain this Owner's Manual for future reference.

Read the Installation Manual before making any installation or finishing changes.

A. Congratulations

Congratulations on selecting a Majestic gas fireplace, an elegant and clean alternative to wood burning fireplaces. The Majestic gas fireplace you have selected is designed to provide the utmost in safety, reliability, and efficiency.

As the owner of a new fireplace, you'll want to read and carefully follow all of the instructions contained in this *Owner's Manual*. Pay special attention to all cautions and warnings.

This *Owner's Manual* should be retained for future reference. We suggest that you keep it with your other important documents and product manuals.

The information contained in this *Owner's Manual*, unless noted otherwise, applies to all models and gas control systems.

Your new Majestic gas fireplace will give you years of durable use and trouble-free enjoyment. Welcome to the Majestic family of fireplace products!

Homeowner Reference Information		<i>We recommend that you record the following pertinent information about your fireplace.</i>	
Model Name:	_____	Date purchased/installed:	_____
Serial Number:	_____	Location on fireplace:	_____
Dealership purchased from:	_____	Dealer Phone:	_____
Notes:	_____		

Listing Label Information/Location The model information regarding your specific fireplace can be found on the rating plate usually located in the control area of the fireplace.

The rating plate contains the following information:

- Type of Gas:** Points to the "NATURAL GAS" section.
- Gas and Electric Information:** Points to the "Minimum Permissible Gas Supply for Purposes of Input Adjustment" table.
- Model Number:** Points to the "Model: XXXXXXXX" field.
- Serial Number:** Points to the "Serial (Serie): XXXXXXXX" field.

MAJESTIC
Majestic, a brand of Hearth & Home Technologies
7571 215th Street West, Lakeville, MN 55044

GAS-FIRED
UL US LISTED

Not for use with solid fuel.
(Ne doit pas être utilisé avec un combustible solide).

Type of Gas (Sorte De Gaz): This appliance must be installed in accordance with local codes, if any; if not, follow ANSI Z223.1 in the USA or CAN/CGA B149 installation codes. *(Installer l'appareil selon les codes ou règlements locaux ou, en l'absence de tels règlements, selon les codes d'installation)*

NATURAL GAS
ANSI Z21XX-XXXX · CSA 2.XX-MXX

Minimum Permissible Gas Supply for Purposes of Input Adjustment.			
Approved Minimum (De Gaz) Acceptable	0.0 in w.c.	(Po. Col. d'eau)	
Maximum Pressure (Pression)	0.0 in w.c.	(Po. Col. d'eau)	
Maximum Manifold Pressure (Pression)	0.0 in w.c.	(Po. Col. d'eau)	
Minimum Manifold Pressure (Pression)	0.0 in w.c.	(Po. Col. d'eau)	
Total Electrical Requirements: 000Vac, 00Hz., less than 00 Amperes			

MADE IN USA

ALTITUDE:	0-0000 FT.	IN CANADA	0000-0000FT.	Model:	XXXXXXXX
MAX. INPUT BTUH:	00,000		00,000	(Modele):	_____
MIN. INPUT BTUH:	00,000		00,000	Serial	XXXXXXXX
ORIFICE SIZE:	#XXXXX		#XXXXX	(Serie):	_____

▲ Safety Alert Key:

- **DANGER!** Indicates a hazardous situation which, if not avoided will result in death or serious injury.
- **WARNING!** Indicates a hazardous situation which, if not avoided could result in death or serious injury.
- **CAUTION!** Indicates a hazardous situation which, if not avoided, could result in minor or moderate injury.
- **NOTICE:** Used to address practices not related to personal injury.

Note: The term “recommend” or “recommended” does not indicate a requirement. It is a best practice suggested by Hearth & Home Technologies®.

Table of Contents

1 Welcome

- A. Congratulations 2
- B. Limited Lifetime Warranty 4

2 Product Specific Information

- A. Appliance Certification 6
- B. Glass Specifications 6
- C. BTU Specifications 6

3 Important Safety and Operating Information

- A. Appliance Safety 7
- B. General Operating Parts 8
- C. Fuel Specifications 8
- D. Wall Surface/TV Guidelines 8
- E. Before Lighting Appliance 10
- F. Lighting Instructions (IPI) 11
- G. Appliance Break-In 12
- H. Heat Management 12
- I. Operation During A Power Outage - IntelliFire Touch® . . 13
- J. Detailed Component Operating Instructions
 - IntelliFire Touch 15

4 Maintenance and Service

- A. Maintenance: Frequency and Tasks 17
- B. Maintenance Tasks - Homeowner 17
- C. Maintenance Tasks - Qualified Service Technician 20

5 Frequently Asked Questions and Troubleshooting

- A. Frequently Asked Questions 22
- B. Frequently Asked Questions - IntelliFire Touch Controls (IFT-RC400) 23
- C. Troubleshooting 24

6 Reference Materials

- A. Accessories 26
- B. Service Parts 27
- C. Contact Information 35

→ = Contains updated information.

B. Limited Lifetime Warranty

Hearth & Home Technologies LLC LIMITED WARRANTY

Hearth & Home Technologies LLC (“HHT”) extends the following warranty for HHT gas, wood, pellet and electric hearth appliances (each a “Product” and collectively, the “Product(s)”) and certain component parts set forth in the table below (“Component Part(s)”) that are purchased from a HHT authorized dealer or distributor.

WARRANTY COVERAGE:

HHT warrants that the Products and their Component Parts will be free from defects in materials and workmanship for the applicable period of Warranty coverage set forth in the table below (“Warranty Period”). If a Product or Component Parts are found to be defective in materials or workmanship during the applicable Warranty Period, HHT will, at our discretion, repair the applicable Component Part(s), replace the applicable Component Part(s), or refund the purchase price of the applicable Product(s). The maximum amount recoverable under this Warranty is limited to the purchase price of the Product. This Warranty is transferable from the original purchaser to subsequent owners, but the Warranty Period will not be extended in duration or expanded in coverage for any such transfer. This Warranty is subject to conditions, exclusions, and limitations as described below.

WARRANTY PERIOD:

Warranty coverage begins at the date of installation. In the case of new home constructions, Warranty coverage begins six months after invoice of the final sale of the Product(s) by an independent, authorized HHT dealer or distributor. However, the Warranty coverage shall commence no later than 24 months following the date of Product shipment from HHT, regardless of the installation or purchase date.

Warranty Period		HHT Manufactured Appliances and Venting					
Component Parts	Labor	Gas	Pellet	Wood	Electric	Component Parts Covered by this Warranty	
1 Year		X	X	X		All parts including handles, external enameled components and other material except as covered by Warranty Conditions, Warranty Exclusions, and Warranty Limitations listed	
2 Years					X	All parts except as covered by Warranty Conditions, Warranty Exclusions, and Warranty Limitations listed	
			X	X		Glass, Electrical components limited to heating element/igniters, Top feed auger assembly, Blowers, Junction Box, Remotes/Wall switches, linear actuator, power cord, vacuum switch, snap disc, wire harnesses and thermocouple	
	X					Electrical components limited to modules, remotes/wall switches, valves, pilots, blowers, junction boxes, wire harnesses, transformers and lights (excluding light bulbs)	
	X			X		Cement Refractory Panels, Glass Liner Panels	
3 years			X			Firepots, burnpots, Harman mechanical feeders	
5 years		X		X		Catalysts, Vented and Vent Free burners and logs	
10 years	1 year	X				Burners, logs and metal/fiber refractory components of HHT manufactured fireplaces or stoves, venting due to poor workmanship	
10 years	3 years		X	X		Castings, Medallions & Baffles, FlexBurn® System (engine, inner cover, access cover and fireback), Firebox and heat exchanger, HHT Chimney & Terminations, Manifolds	
20 years	3 years	X				Firebox and heat exchanger	
All purchased replacement parts and optional accessories							
1 Year	None	X	X	X	X	All purchased replacement parts and optional accessories	

WARRANTY CONDITIONS:

- Because HHT cannot control the quality of any Products sold by unauthorized sellers, this Warranty only covers Products that are purchased through an HHT authorized dealer or distributor unless otherwise prohibited by law; a list of HHT authorized dealers is available on the HHT branded websites.
- This Warranty is only valid while the applicable Product remains at the site of original installation.
- This Warranty is only valid in the country in which the HHT authorized dealer or distributor that sold the applicable Product is authorized to sell applicable Product.
- Contact your installing distributor or dealer for Warranty service. If the installing dealer or distributor is unable to provide necessary parts, contact the nearest HHT authorized dealer or supplier. Additional service fees may apply if you are seeking Warranty service from a dealer other than the dealer from whom you originally purchased the applicable Product.
- No HHT consumer should bear cost of warranty service or costs incurred while servicing warranty claims (i.e., travel, gas, or mileage) when the service is performed within the terms of this Warranty. Check with your dealer or distributor in advance for any costs to you when arranging a warranty call. Travel and shipping charges for parts are not covered by this Warranty.

WARRANTY EXCLUSIONS:

This Warranty does not cover the following:

- Changes in surface finishes as a result of normal use. As a heating appliance, some changes in color of interior and exterior surface finishes may occur. This is not a flaw and is not covered under the Warranty.
- Damage to printed, plated, or enameled surfaces caused by fingerprints, accidents, misuse, scratches, melted items or other external sources and residues left on the plated surfaces from the use of abrasive cleaners or polishes.
- Repair or replacement of parts that are subject to normal wear and tear during the Warranty Period are not covered. These parts include: paint, wood and pellet gaskets, firebricks, wood grates, flame guides, batteries and the discoloration of glass.
- Minor expansion, contraction, or movement of certain parts causing noise. These conditions are normal and complaints related to this noise are not covered by this Warranty.
- Damages resulting from: (1) failure to install, operate, or maintain the applicable Product in accordance with the installation instructions, operating instructions, and listing agent identification label furnished with the applicable Product; (2) failure to install the applicable Product in accordance with local building codes; (3) shipping or improper handling; (4) improper operation, abuse, misuse, continued operation with damaged, corroded or failed components, accident, or improperly/incorrectly performed repairs; (5) environmental conditions, inadequate ventilation, negative pressure, or drafting caused by tightly sealed constructions, insufficient make-up air supply, or handling devices such as exhaust fans or forced air furnaces or other such causes; (6) use of fuels other than those specified in the operation instructions; (7) installation or use of components not supplied with the applicable Product or any other components not expressly authorized and approved by HHT; (8) modification of the appliance not expressly authorized and approved by HHT in writing; and/or (9) interruptions or fluctuations of electrical power supply to the applicable Product.
- Non-HHT venting components, hearth connections or other accessories used in conjunction with the applicable Product.
- Any part of a pre-existing fireplace system in which an insert or a decorative gas applicable Product is installed.
- HHT's obligation under this Warranty does not extend to the Product's capability to heat the desired space. Information is provided to assist the consumer and the dealer in selecting the proper Product for the application. Consideration must be given to the Product location and configuration, environmental conditions, insulation and air tightness of the structure.

This warranty is void if:

- The applicable Product has been over-fired, operated in atmospheres contaminated by chlorine, fluorine, or other damaging chemicals. Over-firing can be identified by, but not limited to, warped plates or tubes, deformation/warping of interior cast iron structure or components, rust colored cast iron, bubbling, cracking and discoloration of steel or enamel finishes.
- The applicable Product is subjected to prolonged periods of dampness or condensation.
- There is any damage to the applicable Product due to water or weather damage which is the result of, but not limited to, improper chimney or venting installation.

LIMITATIONS OF REMEDIES AND LIABILITY:

- **EXCEPT TO THE EXTENT PROVIDED BY LAW, HHT MAKES NO EXPRESS WARRANTIES OTHER THAN THE WARRANTY SPECIFIED HEREIN. The owner's exclusive remedy and HHT's sole obligation under this Warranty or in contract, tort or otherwise, shall be limited to, at HHT's sole option, replacement of the Component Part(s), repair of the Component Part(s), or refund of the original purchase price of the applicable Product(s). In no event will HHT be liable for any incidental or consequential damages caused by defects in the applicable Product. Some States do not allow the exclusion or limitation of incidental or consequential damages, so the above limitation or exclusion may not apply to you. This Warranty gives you specific legal rights and you may also have other rights which vary from State to State. THE DURATION OF ANY IMPLIED WARRANTY IS LIMITED TO DURATION OF THE EXPRESSED WARRANTY SPECIFIED ABOVE FOR THE APPLICABLE PRODUCT. Some States do not allow limitations on how long an implied warranty lasts, so the above limitation may not apply to you.**

2 Product Specific Information

A. Appliance Certification

→ **MODELS:** TRILLIANT25IN, TRILLIANT25IL
 TRILLIANT30IN, TRILLIANT30IL
 TRILLIANT35IN, TRILLIANT35IL
LABORATORY: Underwriters Laboratories, Inc. (UL)
TYPE: Direct Vent Heater
STANDARD: ANSI Z21.88-2019 CSA 2.33-2019

This product is listed to ANSI standards for “Vented Gas Fireplace Heaters” and applicable sections of “Gas Burning Heating Appliances for Manufactured Homes and Recreational Vehicles”, and “Gas Fired Appliances for Use at High Altitudes”.

Gas inserts are designed for installations into solid fuel masonry or factory built fireplaces that have been installed in accordance with the National, Provincial, State and local building codes. Fireplaces are to be constructed of non-combustible materials and, in the absence of local or regional codes, meet criteria of NFPA 211. No additional outside air source is required.

NOTICE: This installation must conform with local codes. In the absence of local codes you must comply with the National Fuel Gas Code, ANSI Z223.1-latest edition in the U.S.A. and the CAN/CGA B149 Installation Codes in Canada.

NOT INTENDED FOR USE AS A PRIMARY HEAT SOURCE.
 This appliance is tested and approved as either supplemental room heat or as a decorative appliance. It should not be factored as primary heat in residential heating calculations.

Installation and service of this appliance should be performed by qualified personnel. Hearth & Home Technologies recommends HHT Factory Trained or NFI certified professionals.



B. Glass Specifications

This appliance is equipped with ceramic glass. Replace glass only with ceramic glass. Please contact your dealer for replacement glass.

C. BTU Specifications

Models <i>(U.S. or Canada)</i>		Maximum Input BTU/h	Minimum Input BTU/h	Orifice Size (DMS)
TRILLIANT25IN (NG)	<i>(0-2000 FT)</i>	27,000	18,900	40
TRILLIANT25IL (Propane)	<i>(0-2000 FT)</i>	25,000	17,500	53
TRILLIANT30IN (NG)	<i>(0-2000 FT)</i>	32,700	22,890	35
TRILLIANT30IL (Propane)	<i>(0-2000 FT)</i>	32,000	22,400	51
TRILLIANT35IN (NG)	<i>(0-2000 FT)</i>	35,000	24,500	33
TRILLIANT35IL (Propane)	<i>(0-2000 FT)</i>	35,000	24,500	50

3 Important Safety and Operating Information

A. Appliance Safety

WARNING! DO NOT operate fireplace before reading and understanding operating instructions. Failure to operate fireplace according to operating instructions could cause fire or injury.



HOT GLASS WILL CAUSE BURNS.

DO NOT TOUCH GLASS UNTIL COOLED.

NEVER ALLOW CHILDREN TO TOUCH GLASS.

- Keep children away.
- CAREFULLY SUPERVISE children in same room as fireplace.
- Alert children and adults to hazards of high temperatures.

High temperatures may ignite clothing or other flammable materials.

- Clothing, furniture, draperies, and other flammable materials must not be placed on or near the appliance.

A barrier designed to reduce the risk of burns from the hot viewing glass is provided with this appliance and must be installed for the protection of children and other at-risk individuals. DO NOT operate the appliance with the barrier removed. If the barrier becomes damaged, the barrier must be replaced with the manufacturer's barrier for this appliance.

Contact your dealer or Hearth & Home Technologies if the barrier is not present or help is needed to properly install one.

Young children should be carefully supervised when they are in the same room as the appliance. Toddlers, young children and others may be susceptible to accidental contact burns.

- A physical barrier is recommended if there are at risk individuals in the house.
- To restrict access to a fireplace or stove, install an adjustable safety gate to keep toddlers, young children and other at risk individuals out of the room and away from hot surfaces.
- Install a switch lock or a wall/remote control with child protection lockout feature.
- Keep remote controls out of reach of children.
- Never leave children alone near a hot fireplace, whether operating or cooling down.

- Teach children to NEVER touch the fireplace.
- Consider not using the fireplace when children will be present.

Contact your dealer for more information, or visit: www.hpba.org/Product-Info/Fireplace-Stove-Heater/Glass-Fronts-Safety.

To prevent unintended operation when not using your fireplace for an extended period of time (summer months, vacations, trips, etc):

- Remove batteries from remote controls.
- Turn off wall controls.
- Set the selector switch on the control module to the off position and remove batteries.



WARNING: This product and the fuels used to operate this product (liquid propane or natural gas), and the products of combustion of such fuels, can expose you to chemicals including benzene, which is known to the State of California to cause cancer and reproductive harm. For more information go to: www.P65Warnings.ca.gov.

Clear Space

WARNING! DO NOT place combustible objects in front of the fireplace or block louvers. High temperatures may start a fire. See Figure 3.1.

Avoid placing candles and other heat-sensitive objects on mantel or hearth. Heat may damage these objects.

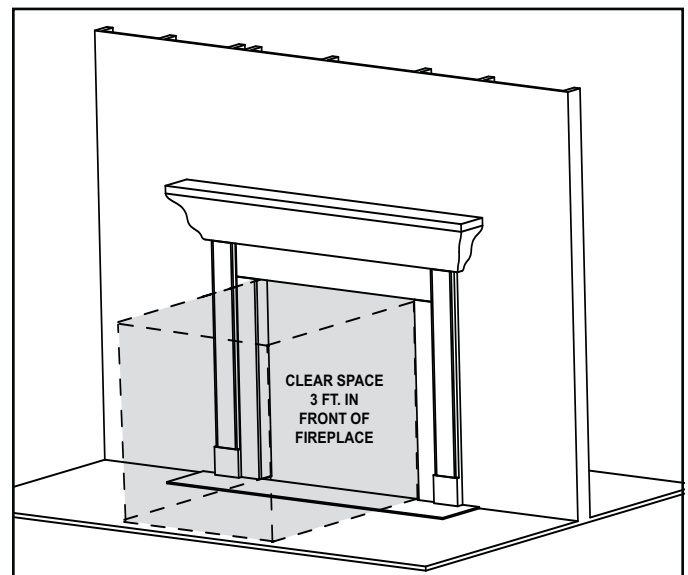

Figure 3.1 Clear Space Requirement - All Models

B. General Operating Parts

Figure 3.2 references the general operating parts of the appliance and the section of this manual in which they are discussed.

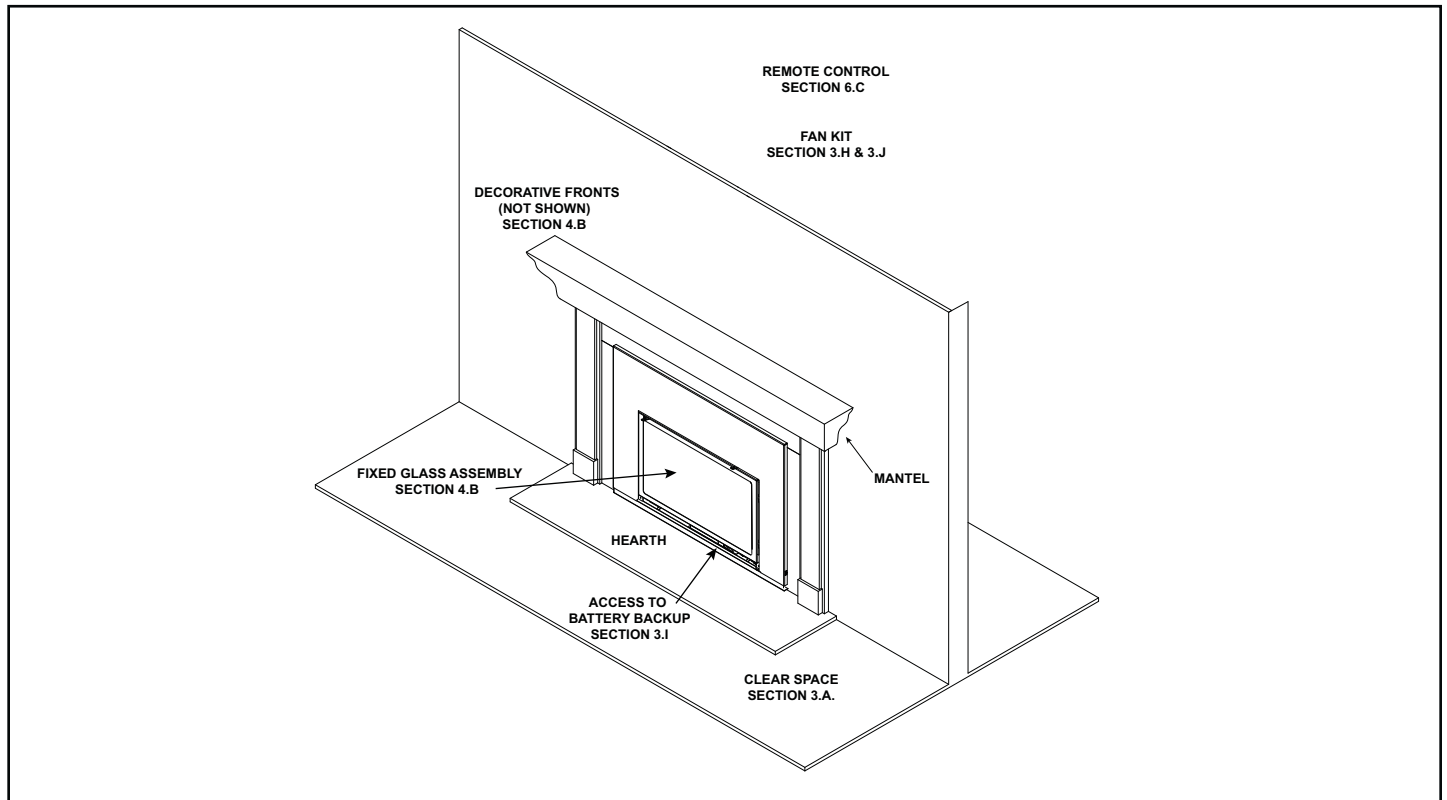

Figure 3.2 General Operating Parts

C. Fuel Specifications

WARNING! Risk of Fire or Explosion! Appliance must be set up for compatible gas type!

- This appliance is designed to operate on either natural gas or propane. Make sure the appliance is compatible with gas type selected for installation site.
- Conversions must be made by a qualified service technician using Hearth & Home Technologies specified and approved parts.

NOTICE: Temperatures listed above are taken with a temperature measuring probe as prescribed by the test standard used for appliance certification. Temperatures on walls or mantels taken with an infrared thermometer may yield increased temperatures of up to 30 °F (17 °C) or more depending on the thermometer settings and material characteristics being measured. Use appropriate finishing materials that are able to withstand these conditions. For additional finishing guidelines, see Section 8 Installation Manual.

D. Wall Surface/TV Guidelines

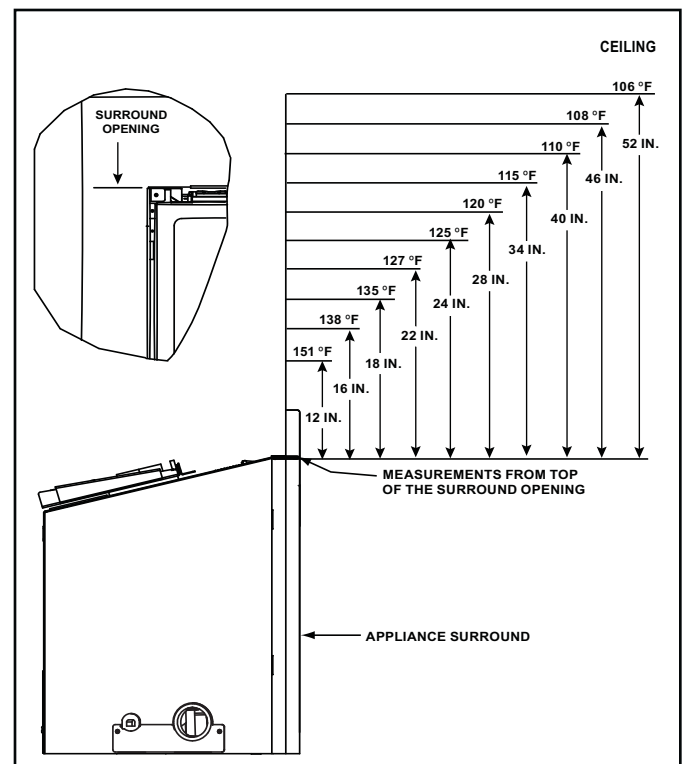
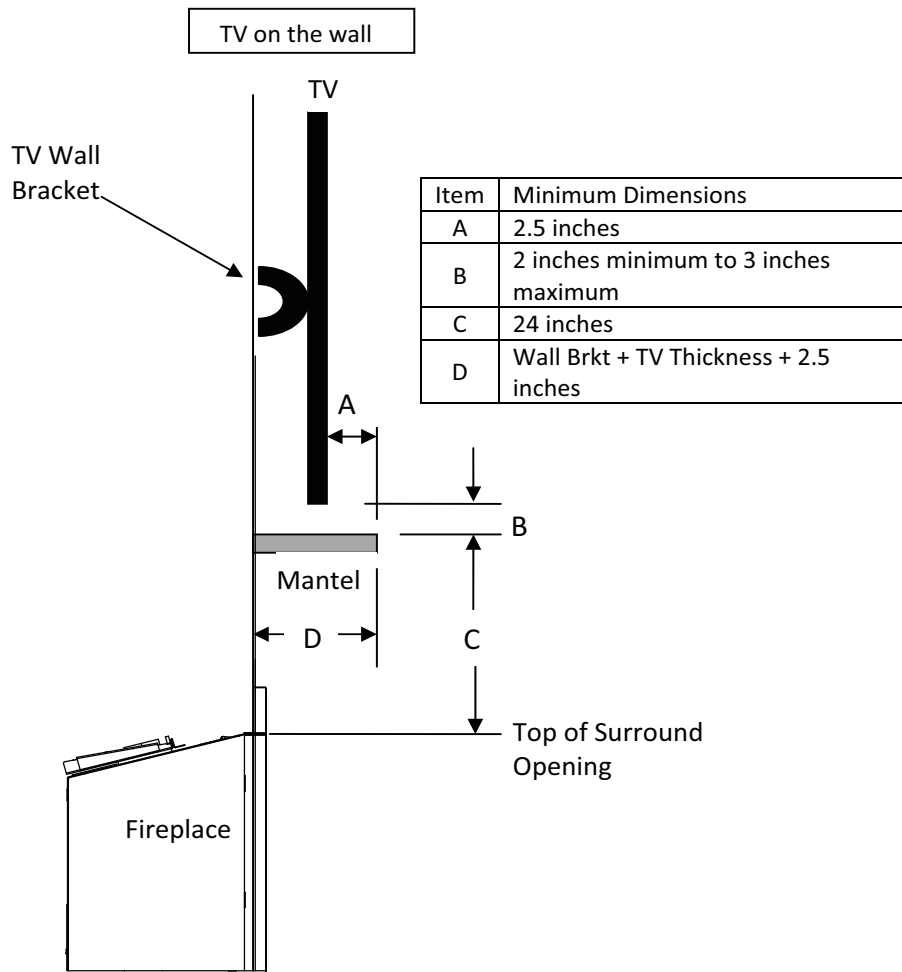

Figure 3.3 Good Faith Wall Surface Temperatures Above Appliance

Good Faith Guidelines for TV Installations above a Gas Fireplace



Notes:

1. These are good faith recommended clearances only and not a guarantee of compliance with all TV manufacturers' maximum allowable operating temperatures.
2. Since every home has unique air flow characteristics and maximum allowable operating temperatures can vary from manufacturer to manufacturer and from model to model, actual TV temperatures should be validated at the time of each installation. TVs should not be used in situations where the actual TV temperature exceeds the manufacturers' maximum allowable operating temperatures identified in the TV's technical specifications. Contact the TV's manufacturer directly if you cannot locate this information or have questions regarding the information.
3. Mantel height and depth must conform to mantle requirements specified in the fireplace installation manual.
4. "C" dimension taken from the top of the hood or fireplace opening.
5. Suggestions on how to further reduce TV temperatures:
 - a. Increase "A" dimension.
 - b. Increase "C" dimension, however, increasing "B" dimension beyond maximum recommended typically results in higher temperatures.

Figure 3.4 Good Faith TV Guidelines

E. Before Lighting Appliance

Before operating this fireplace for the first time, **it is recommended that a qualified service technician:**

- Verify all shipping materials have been removed from inside and/or underneath the firebox.
- Verify multi-purpose tool has been removed and is available.
- Review proper placement of logs, ember material and/or other decorative materials.
- Check the wiring.
- Check the air shutter adjustment.
- Ensure that there are no gas leaks.
- Verify Glass Seal Plate is properly installed. See Figure 3.6.

WARNING! Glass seal plate must be properly installed. Risk of elevated component temps and carbon monoxide exposure.

- Ensure that the glass is sealed and in the proper position and that the integral barrier is in place.

WARNING! Risk of Fire or Asphyxiation! DO NOT operate fireplace with fixed glass assembly removed.

- Verify collar slide plate screw is attached see Figure 3.5.

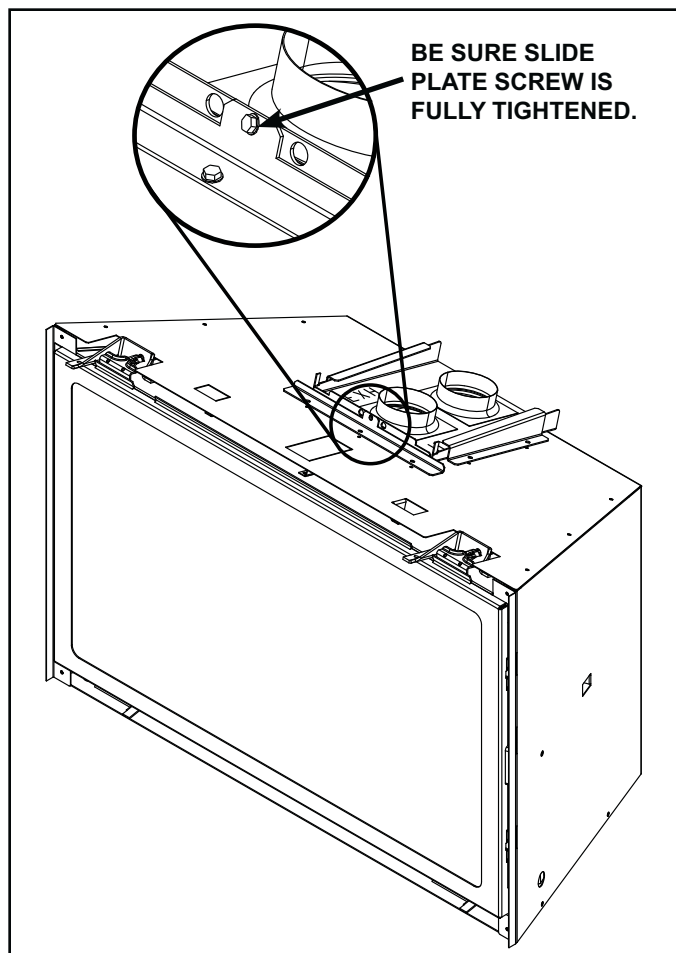

Figure 3.5 Collar slide Plate Screw Detail

F. Lighting Instructions (IPI)

FOR YOUR SAFETY READ BEFORE LIGHTING



WARNING: If you do not follow these instructions exactly, a fire or explosion may result causing property damage, personal injury or loss of life.

- A. This appliance is equipped with an intermittent pilot ignition (IPI) device which automatically lights the burner. **DO NOT** try to light the burner by hand.
- B. **BEFORE LIGHTING**, smell all around the appliance area for gas. Be sure to smell next to the floor because some gas is heavier than air and will settle on the floor.
- WHAT TO DO IF YOU SMELL GAS**
- **DO NOT** try to light any appliance.
 - **DO NOT** touch any electric switch; do not use any phone in your building.
 - Immediately call your gas supplier from a neighbor's phone. Follow the gas supplier's instructions.
 - If you cannot reach your gas supplier, call the fire department.
- C. Use only your hand to push in or turn the gas control knob. Never use tools. If the knob will not push in or turn by hand, **DO NOT** try to repair it, call a qualified service technician. Force or attempted repair may result in a fire or explosion.
- D. **DO NOT** use this appliance if any part has been under water. Immediately call a qualified service technician to inspect the appliance and to replace any part of the control system and any gas control which has been under water.

LIGHTING INSTRUCTIONS (IPI)

1. This appliance is equipped with an ignition device which automatically lights the burner. **DO NOT** try to light the burner by hand.
2. Wait five (5) minutes to clear out any gas. Then smell for gas, including near the floor. If you smell gas, **STOP!** Follow "B" in the Safety Information located on the top of this label. If you do not smell gas, go to next step.
3. To light the burner:
Equipped with wall switch: Turn ON/OFF switch to ON.
Equipped with remote or wall control: Press ON or FLAME button.
Equipped with thermostat: Set temperature to desired setting.
4. If the appliance does not light after three tries, call your service technician or gas supplier.

**GAS
VALVE**

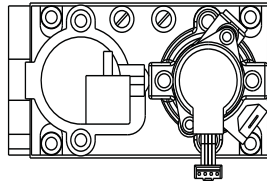

TO TURN OFF GAS TO APPLIANCE

1. Equipped with wall switch: Turn ON/OFF switch to OFF.
Equipped with remote or wall control: Press OFF button.
Equipped with thermostat: Set temperature to lowest setting.
2. Service technician should turn off electric power to the control when performing service.



DANGER



**HOT GLASS WILL CAUSE BURNS.
DO NOT TOUCH GLASS UNTIL COOLED.
NEVER ALLOW CHILDREN TO TOUCH GLASS.**

A barrier designed to reduce the risk of burns from the hot viewing glass is provided with this appliance and must be installed for the protection of children and other at-risk individuals.

WARNING:

DO NOT CONNECT LINE VOLTAGE (110/120 VAC OR 220/240 VAC) TO THE CONTROL VALVE.

Improper installation, adjustment, alteration, service or maintenance can cause injury or property damage. Refer to the owner's information manual provided with this appliance. For assistance or additional information, consult a qualified installer, service agency or the gas supplier.

This appliance needs fresh air for safe operation and must be installed so there are provisions for adequate combustion and ventilation air.



WARNING: This product and the fuels used to operate this product (liquid propane or natural gas), and the products of combustion of such fuels, can expose you to chemicals including benzene, which is known to the State of California to cause cancer and reproductive harm. For more information go to: www.P65Warnings.ca.gov.

Keep burner and control compartment clean. See installation and operating instructions accompanying appliance.

CAUTION:

Hot while in operation. **DO NOT** touch. Keep children, clothing, furniture, gasoline and other liquids having flammable vapors away.

DO NOT operate the appliance with fixed glass assembly removed, cracked or broken. Replacement of the fixed glass assembly should be done by a licensed or qualified service person.

NOT FOR USE WITH SOLID FUEL

For use with natural gas and propane. A conversion kit, as supplied by the manufacturer, shall be used to convert this appliance to the alternate fuel.

Also Certified for Installation in a Bedroom or a Bedsitting Room.

This appliance must be installed in accordance with local codes, if any; if none, follow the *National Fuel Gas Code, ANSI Z223.1/ NFPA 54, or the National Gas and Propane Installation code, CSA B149.1.*

**For additional information on operating your
Hearth & Home Technologies fireplace, please
refer to www.hearthhome.com.**

593-913K

G. Appliance Break-In

NOTICE! Open windows for air circulation during fireplace break-in.

- Some people may be sensitive to smoke and odors.
- Smoke detectors may activate.

Follow the initial break-in procedure below to cure the materials used to manufacture the fireplace and the finishing materials around it.

- The fireplace should be run three to four hours continuously on high.
- Turn the fireplace off and allow it to cool completely.
- Remove fixed glass assembly. See Section 4.B.
- Clean fixed glass assembly. See Section 4.B.
- Verify Glass Seal Plate is properly installed. See Figure 3.6.

WARNING! Glass seal plate must be properly installed. Risk of elevated component temps and carbon monoxide exposure.

- Replace the fixed glass assembly.

Note: Some installations may require additional run time to cure. If odors persist after the initial break-in period, run the fireplace for an additional three to four hours continuously on high.

Note: Some IPI systems have a safety feature that automatically shuts down the fireplace after 9 hours of continuous operation without receiving a command from the remote control. If this occurs, restart the appliance.

- Verify collar slide plate screw is attached see Figure 3.5.

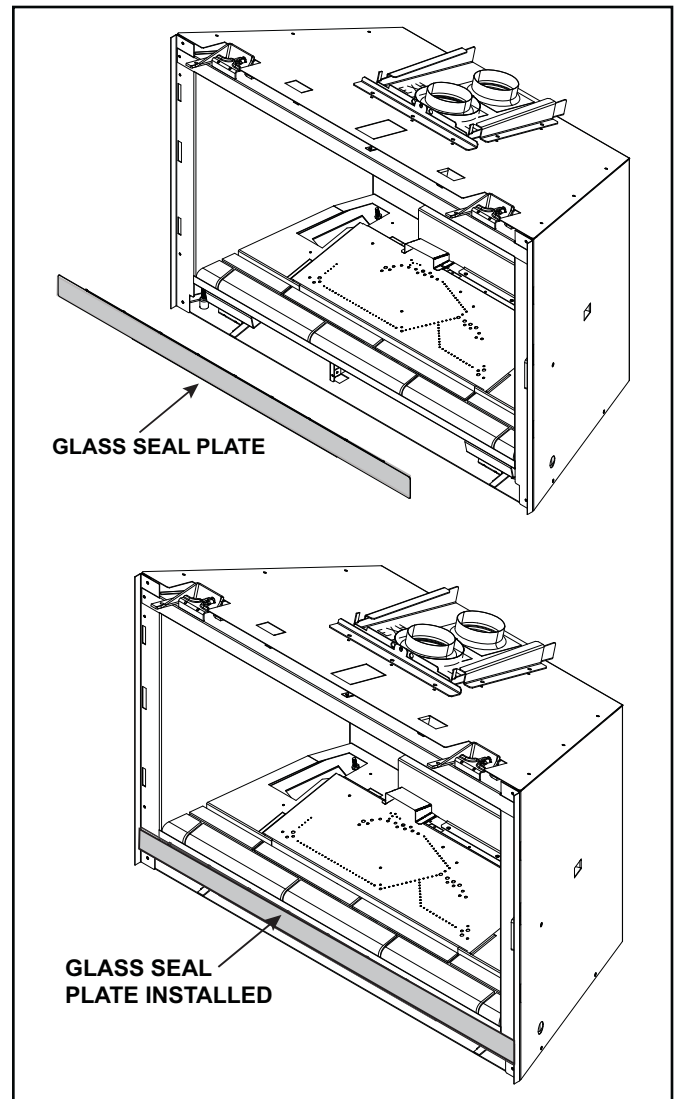

Figure 3.6 Glass Seal Plate

H. Heat Management

Heat Output

Heat output may be controlled by adjusting the “FLAME” setting and “FAN” setting on the RC-400 remote control.

NOTICE! Set the fan speed to high on the RC400 remote control during the first three to four hours of break-in operation. See Section G. This break-in will ensure optimum speed control of the fan during subsequent use.

SEE SECTION 4 FOR COMPONENT ACCESS DETAILS.

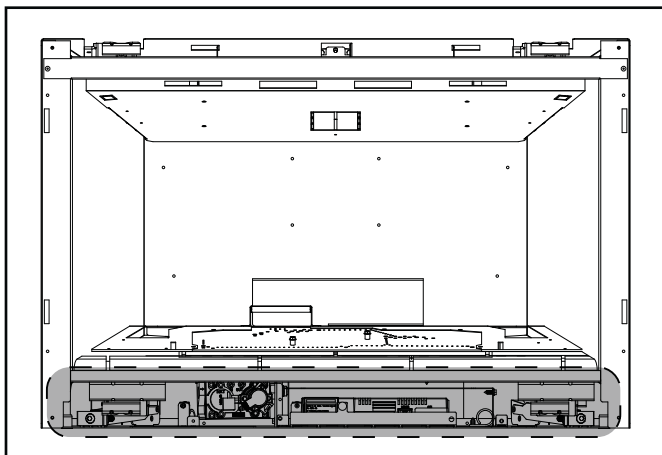

Figure 3.7 Control Cavity

I. Operation During A Power Outage - IntelliFire Touch®

The IntelliFire Touch intermittent pilot ignition system comes with a battery backup system that enables the system to operate in a power outage. This gas appliance is equipped with a USB-C connector to use battery backup power sources. The included 4xAA battery backup power source can support gas appliance operation for up to 72 hours. Other optional battery backup power sources may be used, and could support gas appliance operation for up to 172 hours (7 days). The optional battery backup power sources will require a single cable that has USB-C male connectors to connect the gas appliance to a battery backup power source or any other commercially available battery power sources such as laptops or Lithium-Ion based battery pack (power bank) chargers.

NOTICE: Batteries should only be used as a power source in the event of an emergency power outage. Batteries should not be used as a primary long-term power source.

Operation with 4xAA Battery Backup Power Source:

1. The decorative barrier front should be removed to ease the connection of the battery pack and replaced during operation of the appliance.
2. Locate the USB-C battery power source that was shipped in the gas appliance manual bag.
3. Insert 4xAA batteries into the battery backup power source.
4. Make sure that the 4xAA batteries are inserted matching the indicators shown on the battery backup power source. If not installed correctly, module damage could occur. A complete wiring diagram is included in the Electrical section of the appliance installation manual.

5. Locate the USB-C connector on the appliance as shown in Figure 3.8. Remove rubber plug from the USB-C port and insert the battery backup power source USB-C connector into the appliance USB-C port. Save USB-C rubber plug for reusing after power has been restored.
6. Place the battery backup power source away from any heat source and hot surface to the extent possible. Excessive heat will reduce the battery life. See Figure 3.8.
7. Turn on the gas appliance by using one of the IFT control devices, RC150 Wireless Wall Switch or RC400 Remote Control, or through the Ignition Module.

IFT-RC150 Wireless Wall Switch:

- Toggle the switch as you would under normal circumstances.

IFT-RC400 Wireless Remote:

- Remote receiver is integrated into the ignition module
- Use the remote to turn the appliance on.
- To preserve battery life, do not use the HI/LO flame or THERMOSTAT options.

Ignition Module:

- Access to the control cavity (Figure 3.7) will require the decorative barrier front, glass panel and the glass seal plate to be removed.
- Slide the ON/REMOTE/OFF switch to the ON position.
- Replace the glass seal plate, glass panel and decorative barrier front. The decorative barrier front must be installed while operating the appliance.

Note: If the appliance is equipped with Wi-Fi, the IFT-Wi-Fi app will not be available to control the gas appliance during the AC power loss. The following events will take place from the Wi-Fi app control device.

- The Wi-Fi app will stop communicating with the gas appliance.
- The Wi-Fi app will display the following error message on the app device screen: “Your appliance is currently offline”.
- The error message may take up to 5-10 minutes to be displayed on the app device screen.

NOTICE: Some functionality will be lost when using the battery backup power source. The IFT-RC400 remote control will not operate fan, lights, or any other auxiliary functions that require the AC power.

Operation with Laptop:

The USB-C equipped gas appliance can be easily operated from a laptop during an AC power loss.

The following steps should be followed to turn on the gas appliance.

1. A single cable that has USB-C male connectors or an older version USB cable with suitable adapter is required.
2. Establish a connection between the USB port (USB-C or older version USB) of the laptop and the USB-C port of the gas appliance.
3. The power settings of the laptop may be readjusted to increase runtime from the laptop battery.
4. Make sure that the laptop is kept away from any heat source and hot surface while operating.
5. When the AC power is restored, disconnect the laptop from the USB-C of the gas appliance by removing the USB-C connection cable.

Operation with Portable USB Battery Packs (Power Banks):

The USB-C port can also be used to operate a gas appliance from portable battery packs that charge smartphones and other portable devices.

NOTICE: Some power banks and many USB battery packs may switch off if the current being drawn is too low. IF this is the case, different low power devices such as a cell phone, laptop, etc. can be attached to the portable USB battery packs while operating the gas appliance. Any additional load may work to keep a portable USB battery pack active to run the gas appliance.

To Return Operation Using Electrical (AC) Power:

IFT-RC400 Wireless Remote, IFT-RC400 Wireless Remote:

- Unplug the USB-C battery backup power source from the USB-C port of the gas appliance. Replace the USB-C rubber plug back into port on appliance.
- Remove the 4xAA batteries from the battery pack power source.

Ignition Module:

- Slide the ON/REMOTE/OFF switch to the Remote position.
- Unplug the USB-C battery backup power source from the USB-C port of the gas appliance. Replace the USB-C rubber plug back into port on appliance.
- Remove the 4xAA batteries from the battery pack power source.
- Replace any items removed, including the decorative barrier front..

DISCLAIMER: *This port is not a power input port or power source. No data input or output.*

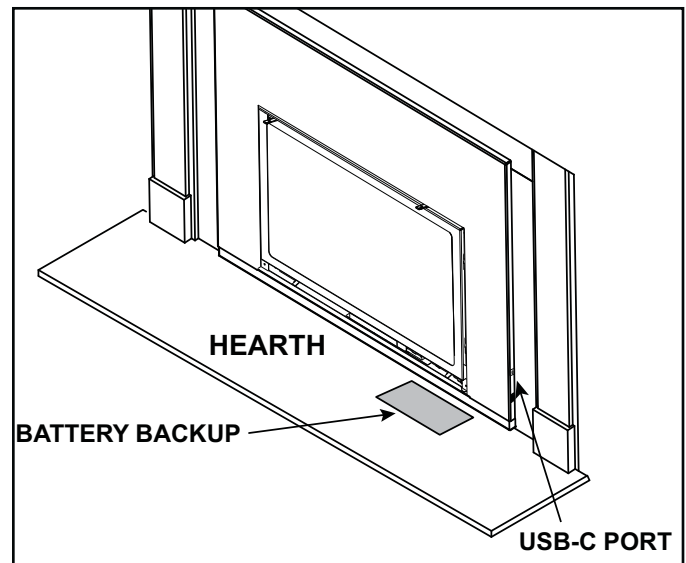

Figure 3.8

J. Detailed Component Operating Instructions - IntelliFire Touch

IFT-ECM Detailed Operating Instruction

This model is shipped from the factory equipped with the IFT-RC400 remote.

SEE SECTION 4 FOR COMPONENT ACCESS DETAILS.

1. The Electronic Control Module (IFT-ECM) has a three-position ON/OFF/REMOTE selector switch that must be set for proper operation. See Figure 3.9. When changing switch positions, it is important to pause in each position for 1-2 seconds.

OFF Position:

The appliance will not respond to any commands from a wired wall switch, IFT-RC150 or IFT-RC400 remote controls. The unit should be in the OFF position during installation, service, backup battery installation, fuel conversion and to reset the IFT-ECM in the event the system goes into a LOCK-OUT mode as the result of a system error. When switched to the OFF position while the appliance is operating, the system will shut down.

ON Position:

The appliance will ignite and run continuously at the HI flame setting. No adjustment in flame height is possible.

The IFT-ECM has a safety feature that will automatically shut down the fireplace after 9 hours of continuous operation in the ON position, except when operated in active thermostat mode.

Remote Position:

The remote position allows operation of the appliance from a wired wall switch, IFT-RC400 or IFT-RC150 remote controls. The IFT-ECM switch must be in this position to pair the IFT-ECM with the IFT-ACM (if installed), and/or IFT-RC400 and IFT-RC150 remote controls. See the IFT-RC400 or IFT-RC150 installation manual for detailed instructions on pairing the IFT-ECM with the remote controls. After successfully pairing a IFT-RC400, all installed accessories can be controlled by the IFT-RC400 (see IFT-RC400 user manual). The RC150 allows the user to turn ON/OFF the flame in the appliance and activate the Cold Climate mode if desired. The IFT-ECM has a safety feature that will automatically shut down the fireplace after 9 hours of continuous operation without receiving a command from the IFT-RC400, IFT-RC150 or wired wall switch.

2. If multiple control options are installed, the IFT-ECM will respond to the last command from the wired wall switch, IFT-RC400 or IFT-RC150.

3. The Pilot button on the IFT-ECM activates the Cold Climate function of the fireplace. This function lights the pilot flame ONLY to provide enough heat in the firebox to reduce condensation in cool, high humidity ambient conditions. To activate the Cold Climate press and hold the Pilot button for one second and release. The IFT-ECM will flash two green LED blinks, beep twice and light and rectify the pilot flame. To turn off Cold Climate, press and hold the Pilot button for one second and release. The IFT-ECM will flash one green LED blink, beep once and shut down the pilot flame. If remote controls are paired with the IFT-ECM, this feature can also be activated with the IFT-RC400 and/or IFT-RC150.

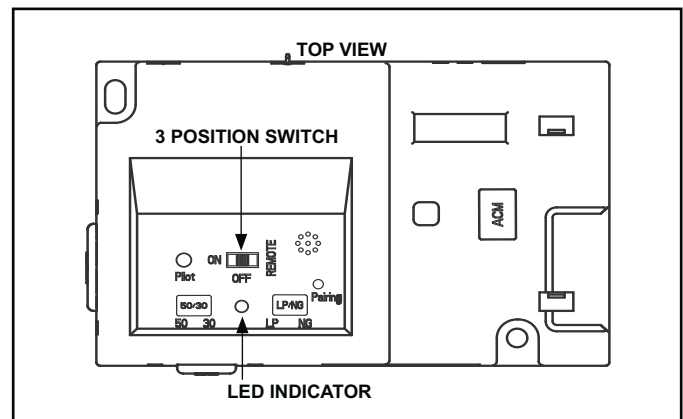

Figure 3.9 IFT-ECM

DANGER

Risk of Explosion

DO NOT cycle the ON/OFF/REM selector switch more than one time within a five minute period. Gas may accumulate in firebox. Call a qualified service technician.

4. An IFT-ECM reset is required if the module is in a lock-out condition. When this occurs, the appliance is shut down and the IFT-ECM status indicator LED will be blinking a RED/GREEN error code along with a one-time audible double-beep. If the IFT-ECM is in a lock-out condition, refer to the troubleshooting chart to interpret the error code and take corrective action as required. To reset the IFT-ECM after a lock-out error:

CAUTION! Risk of burns! Appliance surfaces are hot when operating and during cool down. Use care and wear gloves when opening the front and accessing components inside the appliance.

- Toggle the appliance reset switch to the off position. See Figure 3.10 for reset switch location.

or

- Set the IFT-ECM 3-position selector switch to OFF position.
- Wait five (5) minutes to allow possible accumulated gas to clear.
- Toggle the appliance reset switch to the on position.

or

- Set the IFT-ECM 3-position selector switch to ON or REMOTE position. Module will beep once and flash a three GREEN LED code on successful startup.

If placed in ON position, the appliance will ignite normally if the error condition was corrected.

If placed in IFT-REM position or reset switch used, use the paired IFT-RC400, IFT-RC150 or wired wall switch to start the appliance; appliance will ignite normally if the error condition was corrected.

If the IFT-ECM re-enters the lock-out condition after these steps, call your dealer for service.

Appliance ON/OFF:

A wall control, thermostat or remote control may be used to control the ON/OFF function of the appliance. Follow instructions included with the installed control. Contact your dealer for details.

Fan Kit

- This appliance includes a factory installed fan.
- Fan functions are integrated into the included IFT-RC400 remote control.

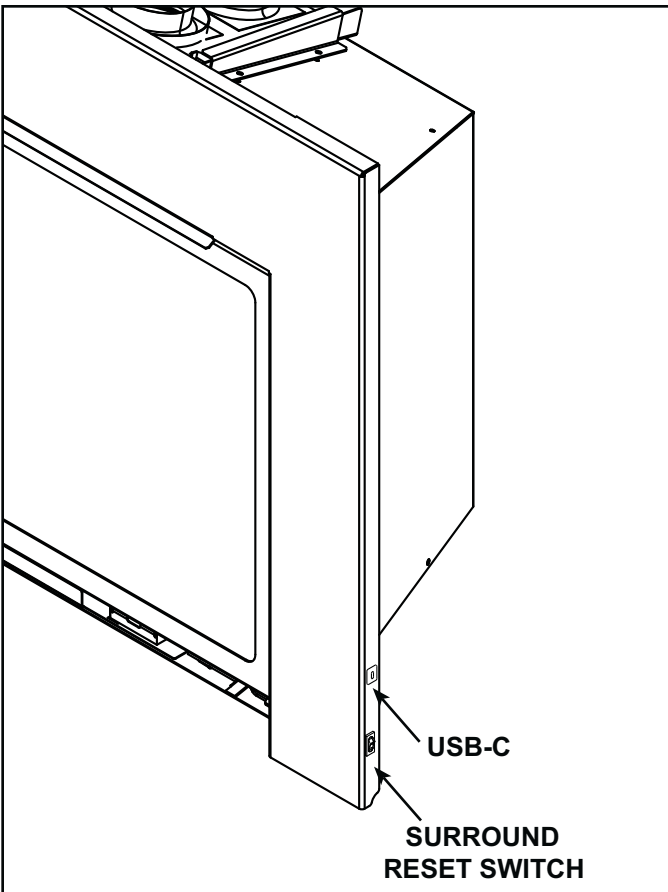

Figure 3.10 Surround Reset Switch and USB-C Battery Backup Port

4 Maintenance and Service

Any safety screen or guard removed for servicing must be replaced prior to operating the fireplace.

When properly maintained, your fireplace will give you many years of trouble-free service. **Contact your dealer** to answer questions regarding proper operation, trouble-shooting and service for your appliance. Visit www.majesticproducts.com to locate a dealer. We recommend annual service by a qualified service technician.

A. Maintenance: Frequency and Tasks

Task	Frequency	To be completed by
Decorative Barrier Front	Annually	Homeowner
Glass Cleaning	Seasonally	
Control Access	Seasonally	
Remote Control	Seasonally	
Venting	Seasonally	
Gasket Seal and Glass Inspection	Annually	Qualified Service Technician
Log Inspection	Annually	
Firebox Inspection	Annually	
Control Compartment & firebox Top	Annually	
Burner Ignition & Operation	Annually	

B. Maintenance Tasks - Homeowner

Installation and repair should be done by a qualified service technician only. The appliance should be inspected before use and at least annually by a professional service person.

The following tasks may be performed annually by the homeowner. If you are uncomfortable performing any of the listed tasks, please call your dealer for a service appointment.

More frequent cleaning may be required due to excessive lint from carpeting, bedding material, etcetera. It is imperative that control compartments, burners and circulating air passageways of the appliance be kept clean. Any safety screen, guard, or barrier removed for servicing the appliance must be replaced prior to operating the appliance.

CAUTION! Risk of Burns! The fireplace should be turned off and cooled before servicing.

Decorative Barrier Front

Frequency: Annually

By: Homeowner

Tools needed: Protective gloves, stable work surface

- Assess condition of screen and replace as necessary.
- Inspect for scratches, dents or other damage and repair as necessary.
- Vacuum and dust surfaces.

Glass Cleaning

Frequency: Seasonally

By: Homeowner

Tools Needed: Protective gloves, glass cleaner, drop cloth, multi-purpose tool, and a stable work surface.

CAUTION! Handle fixed glass assembly with care. Glass is breakable.

- Avoid striking, scratching or slamming glass
- **DO NOT** use abrasive cleaners
- **DO NOT** clean glass while it is hot
- Prepare a work area large enough to accommodate fixed glass assembly and door frame by placing a drop cloth on a flat, stable surface.

Note: Fixed glass assembly and gasketing may have residue that can stain carpeting or floor surfaces.

- Remove door or decorative barrier front from fireplace and set aside on work surface.

Removing Fixed Glass Assembly

WARNING! Risk of Asphyxiation! Handle fixed glass assembly with care. Inspect the gasket to ensure it is undamaged and inspect the glass for cracks, chips or scratches.

- **DO NOT** strike, slam, or scratch glass.
- **DO NOT** operate fireplace with glass removed, cracked, broken or scratched.
- Replace as a complete assembly.
- The glass assembly fastens to the fireplace in four places. The four fastening mechanisms are spring-loaded glass latches. An example of the glass latch is shown in Figure 4.2.
- To release glass assembly, use the supplied multi-purpose tool. See Figure 4.1. While supporting the glass assembly, pull the two bottom spring-loaded latches forward and allow them to retract away from the glass assembly. Tilt the bottom of the glass assembly outward until the top latches disengage.
- Clean glass with a non-abrasive commercially available cleaner.
 - Light deposits: Use a soft cloth with soap and water.
 - Heavy deposits: Use commercial fireplace glass cleaner (consult with your dealer).

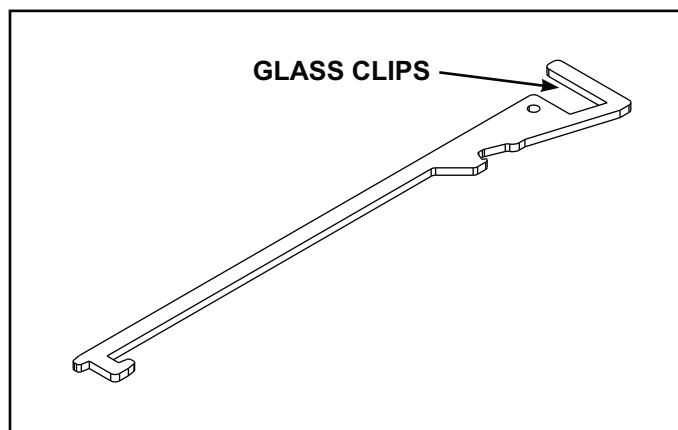

Figure 4.1 Multi-Purpose Tool

Replacing Fixed Glass Assembly

- Verify Glass Seal Plate is properly installed. See Figure 4.3.

WARNING! Glass seal plate must be properly installed. Risk of elevated component temps and carbon monoxide exposure.

- Tilt the top of the glass assembly toward fireplace and slide glass assembly upward to engage top latches. Verify top latches are fully engaged and then fasten the two bottom latches using the supplied multi-purpose tool.
- Reinstall door or decorative barrier front.

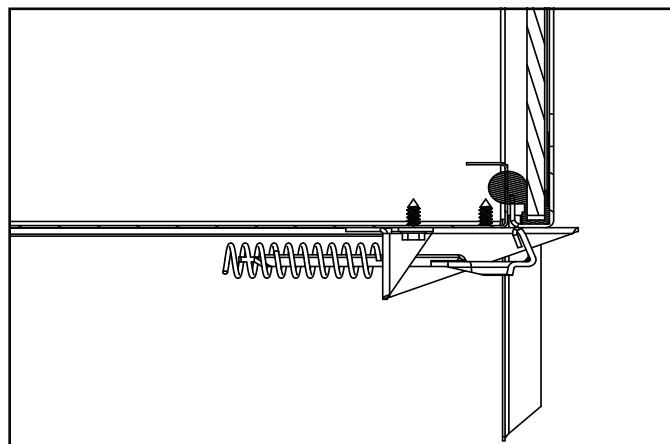

Figure 4.2. Fixed Glass Assembly

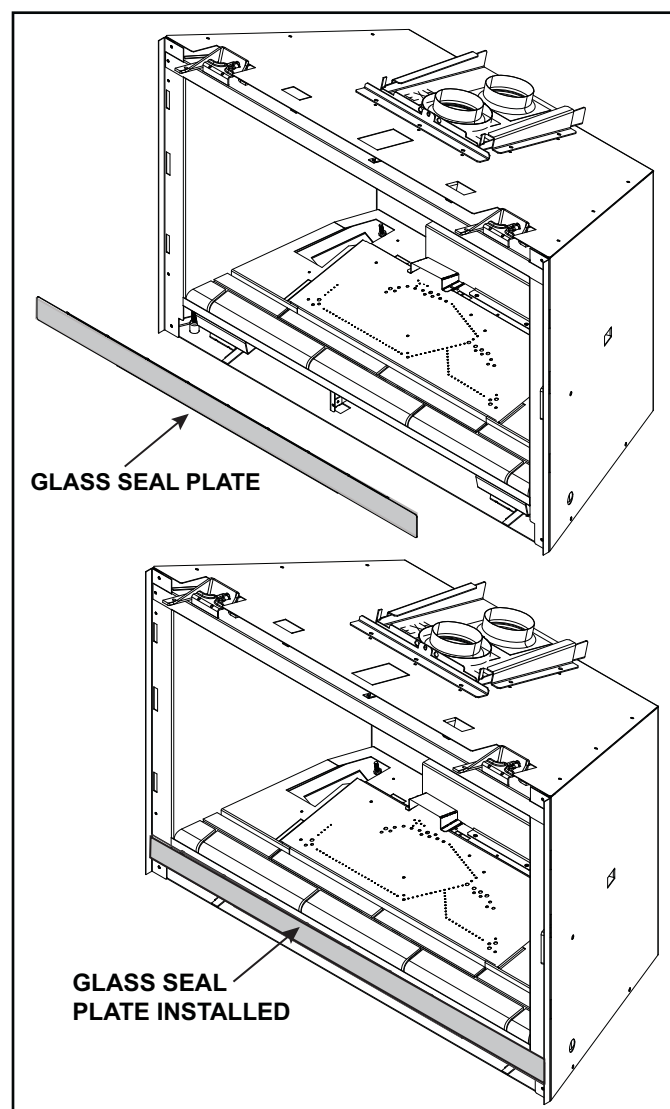

Figure 4.3 Glass Seal Plate

Control Cavity Access

Tools needed: Protective gloves, multi-purpose tool

- Remove decorative barrier front.
- Remove fixed glass assembly.
- Remove glass seal plate. See Figure 4.3.
- For easier access, glass clip assemblies can be removed. See Figure 4.5. Be careful when handling base refractory.

Note: Bottom right glass clip on 25 inch models must be removed to gain access to controls.

- For access, slide out component tray. See Figure 4.4.

Note: Wires may need to be removed from clips for full access. See Figure 4.4.

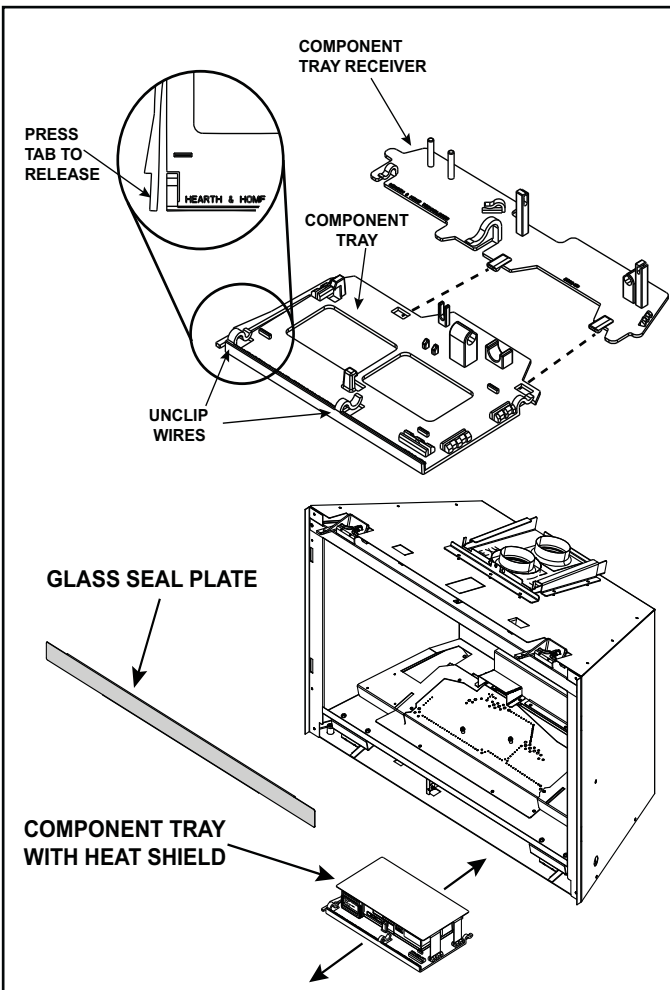

Figure 4.4 Component Tray Access

CAUTION: Be sure to reinstall the component heat shield before firing the appliance. Components will overheat without the heatshield in place.

CAUTION: Be sure to reinstall wires into the retaining clips.

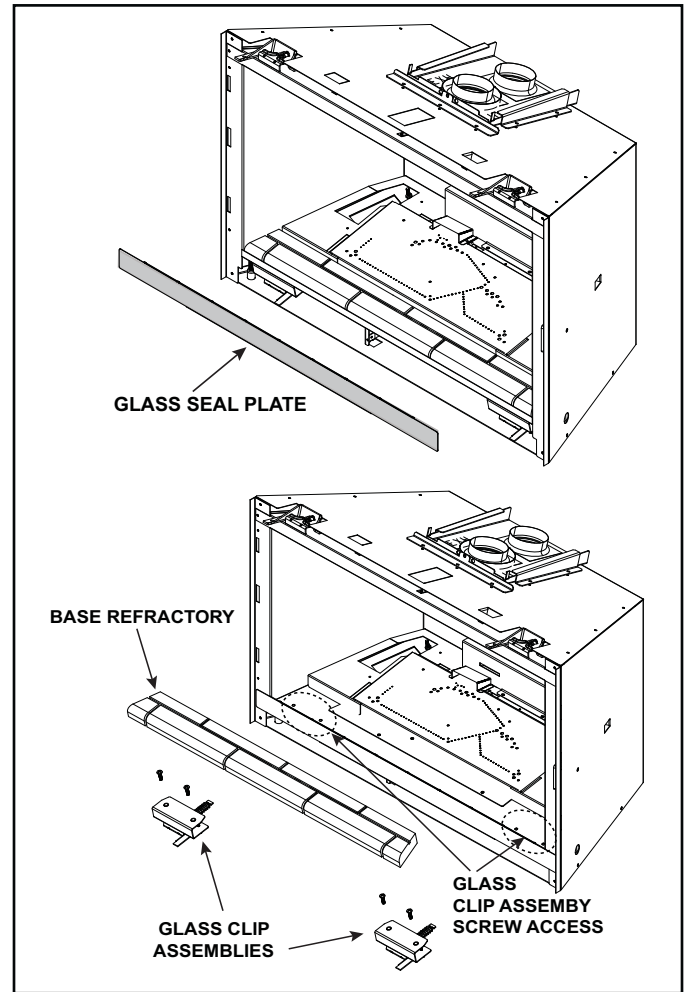

Figure 4.5 Glass Clip Removal

Remote Control

Frequency: Seasonally

By: Homeowner

Tools needed: Replacement batteries and remote control instructions.

- Locate remote control transmitter and receiver.
- Verify operation of remote. Refer to remote control operation instructions for proper calibration and setup procedure.
- Replace batteries as needed in remote transmitters.
- Place remote control out of reach of children.

If not using your fireplace for an extended period of time (summer months, vacations/trips, etc), to prevent unintended operation:

- Remove batteries from remote controls.
- Turn the ON/OFF/REMOTE switch on the control module to OFF.

Venting

Frequency: Seasonally

By: Homeowner

Tools needed: Protective gloves and safety glasses.

- Inspect venting and termination cap for blockage or obstruction such as plants, bird nests, leaves, snow, debris, etc.
- Verify termination cap clearance to subsequent construction (building additions, decks, fences, or sheds).
- Verify collar slide plate screw is attached see Figure 3.5.
- Inspect for corrosion or separation.
- Verify weather stripping, sealing and flashing remains intact.
- Inspect draft shield to verify it is not damaged or missing.

C. Maintenance Tasks - Qualified Service Technician

The following tasks must be performed by a qualified service technician.

Gasket Seal and Glass Assembly Inspection

Frequency: Annually

By: Qualified Service Technician

Tools needed: Protective gloves, drop cloth, multi-purpose tool, and a stable work surface.

- Inspect gasket seal and its condition.
- Inspect fixed glass assembly for scratches and nicks that can lead to breakage when exposed to heat.
- Confirm there is no damage to glass or glass frame. Replace as necessary.
- Verify that fixed glass assembly is properly retained and attachment components are intact and not damaged. Replace as necessary.
- Verify Glass Seal Plate is properly installed. See Figure 4.3.

WARNING! Glass seal plate must be properly installed. Risk of elevated component temps and carbon monoxide exposure.

Logs

Frequency: Annually

By: Qualified Service Technician

Tools needed: Protective gloves.

- Inspect for damaged or missing logs. Replace as necessary. Refer to Installation manual for log placement instructions.
- Verify correct log placement and no flame impingement causing sooting. Correct as necessary.

Control Compartment and Firebox Top

Frequency: Annually

By: Qualified Service Technician

Tools needed: Protective gloves, vacuum cleaner, dust cloths

- Vacuum and wipe out dust, cobwebs, debris or pet hair. Use caution when cleaning these areas. Screw tips that have penetrated the sheet metal are sharp and should be avoided.
- Verify that the collar slide plate screw is installed. See Figure 3.5.
- Remove all foreign objects.
- Verify unobstructed air circulation.
- Ensure no wire connections become disengaged.

Burner Ignition and Operation

Frequency: Annually

By: Qualified Service Technician

Tools needed: Protective gloves, vacuum cleaner, whisk broom, flashlight, voltmeter, indexed drill bit set, and a manometer.

- Verify burner is properly secured and aligned with pilot or igniter.
- Clean off burner top, inspect for plugged ports, corrosion or deterioration. Replace burner if necessary.
- Replace Glowing Embers® with new dime-size pieces. **DO NOT** block ports or obstruct critical lighting paths. Refer to appliance installation manual for proper ember placement.
- Verify batteries have been removed from battery back-up IPI systems to prevent premature battery failure or leaking.
- Check for smooth lighting and ignition carryover to all ports. Verify that there is no ignition delay. Inspect and ensure the lighting of the main burner occurs within four seconds of the main gas valve opening.
- Inspect for lifting or other flame problems.
- Verify air shutter setting is correct. See Installation Manual for required air shutter setting. Verify air shutter is clear of dust and debris.
- Verify vertical restrictor setting is correct. See Installation Manual for required vertical restrictor setting.
- Inspect orifice for soot, dirt and corrosion. Verify orifice size is correct. See Service Parts List for proper orifice sizing.
- Verify manifold and inlet pressures. Adjust regulator as required.
- Check all accessible gas-carrying tubes, connections, pipes and other components for leaks.
- Inspect pilot flame pattern and strength. See Figure 4.6 for proper pilot flame pattern. Clean or replace orifice spud as necessary.
- Inspect IPI flame sensing rod for soot, corrosion and deterioration. Polish with fine steel wool or replace as required.
- Verify that there is not a short in flame sense circuit by checking continuity between pilot hood and flame sensing rod. Replace pilot as necessary.

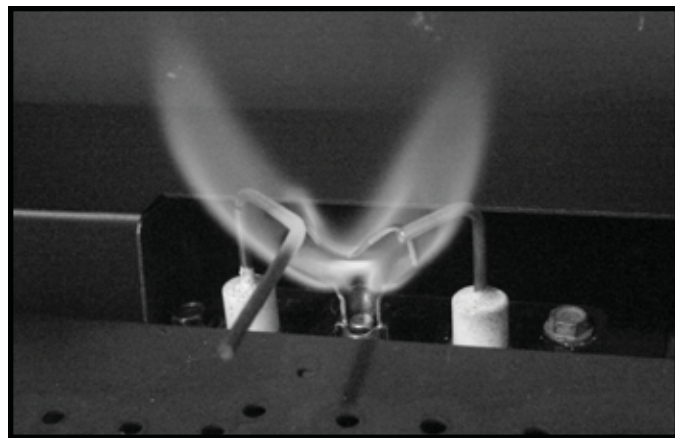

Figure 4.6 IPI Pilot Flame Patterns

5 Frequently Asked Questions and Troubleshooting

A. Frequently Asked Questions

ISSUE	SOLUTIONS
Condensation on the glass	<p>This is a result of gas combustion and temperature variations. Prior to appliance being turned on, the inside of the glass has cooled below the dew point producing a byproduct of combustion: water in the form of condensation. As the fireplace glass warms, the condensation will disappear.</p> <p>In the summer, the inside of your fireplace contains hot humid air from outdoors. When the air from outdoors contacts glass cooled below the dew point by your air conditioning, moisture in that air will condense.</p>
Blue flames	This is a result of normal operation and the flames will begin to yellow as the appliance is allowed to burn for 20 to 40 minutes.
Erratic flames	<p>Verify that the glass assembly is correctly installed and that all four glass latches are engaged over the four tabs on the glass frame.</p> <p>Vent baffle/flue restrictor may be needed when long vertical vent runs are used. Refer to Installation Manual, Section 7: Venting.</p>
Odor from appliance	When first operated, this appliance may release an odor for the first several hours. This is caused by the curing of the paint and the burning off of any oils remaining from manufacturing. Odor may also be released from finishing materials and adhesives used around the appliance. See recommended appliance break-in procedures (Section G).
Film on the glass	This is a normal result of the curing process of the paint and logs. Glass should be cleaned within 3 to 4 hours of initial burning to remove deposits left by oils from the manufacturing process. A non-abrasive cleaner such as gas fireplace glass cleaner may be necessary. See your dealer.
Metallic noise	Noise is caused by metal expanding and contracting as it heats up and cools down, similar to the sound produced by a furnace or heating duct. This noise does not affect the operation or longevity of the appliance.
Is it normal to see the pilot flame burn continually?	In an intermittent pilot ignition system (IPI), the pilot flame should turn off when appliance is turned off. The factory supplied RC-400 has a "Pilot-on" feature labeled as cold climate.
Power Outages (battery backup)	This appliance can operated on battery power in the event of a power outage. To install the battery pack, the decorative barrier front must be removed. The battery pack is shipped in the appliance manual bag (4 AA batteries required). Refer to Section 3.1 for more details.

Contact your dealer for additional information regarding operation and troubleshooting. Visit www.majesticproducts.com to locate a dealer.

B. Frequently Asked Questions - IntelliFire Touch Controls (IFT-RC400)

Symptom	Possible Cause	Corrective Action
The appliance does not respond to commands from the remote control display does not light up when screen is touched.	Batteries are depleted.	Verify batteries are new.
	Batteries are incorrectly oriented.	Verify batteries are installed in correct orientation as shown on batteries receptacle.
The display on remote lights up when screen is touched but it does not respond to commands.	Touchscreen has lost calibration.	Touchscreen needs to be re-calibrated. Call dealer to have screen re-calibrated.
	Child Lock is ON.	Check child lock icon located at the top of the remote display. If ON, it will show as a 'locked' symbol. To unlock, remove battery compartment door, locate child lock switch and move to 'unlock' position. Verify child lock icon on screen is now displayed in 'unlock' position.
The remote displays the following message on-screen: No dealer info available.	Dealer information not programmed into remote.	Remote will still provide all available functions, and appliance is fully available for use. Call dealer to have them program.
The remote displays the following message on-screen: Call "Dealer Name & Number" to schedule maintenance.	300 hours of use. Appliance is still fully functional.	The appliance has been burning for 300 hours and is due for a regular maintenance. Call dealer to have them perform maintenance.
The room temperature displayed on the remote is either slow or quick to respond while operating in thermostat mode.	Remote is placed at a very short distance or too far away from the appliance.	Try to keep the remote close to the appliance but not directly in front of it. The remote acts as the thermostat.
	Remote is placed in the path of an air draft or vent.	Move the remote away from the direct path of air flow. The remote acts as the thermostat.
	Flame Modulation	The control system is designed to automatically adjust the flame intensity based on the difference between the desired room temperature, and actual temperature. In thermostat mode, the hearth appliance will start in HI flame, but as the actual temperature approaches the desired set temperature on the remote, the flame intensity will automatically decrease. Automatic flame modulation will result in more control of the temperature, and will cause the appliance to cycle OFF/ON less.
The appliance turns OFF the flame after extended periods of operation.	9 hour safety shutdown timer	This is normal behavior. The appliance has a safety timer that will automatically turn OFF the flame after nine hours of uninterrupted operation.
The remote displays the following message on-screen: Fan will turn on within 3 minutes.	Functioning as intended.	The appliance has a three minute delay timer before the fan is turned ON. This allows the air surrounding the appliance to be heated before being pushed into the room.
The remote displays the following message on-screen: "Replace remote batteries."	Low batteries in remote.	Install new batteries in the remote.
The remote is displaying an incorrect brand.	Remote was programmed incorrectly.	Call dealer to have them program the remote with correct branding. Remote is still fully functional and the appliance is unaffected.
After turning flame ON using remote, the flame does not turn ON immediately and instead a two minute timer is displayed.	Power vent is installed on the appliance.	This is expected behavior and the two minute timer is called a pre-purge timer. The flame will turn ON at the expiration of the timer.
The remote displays the following message on-screen: "Remote Control Communication Error."	No power to appliance.	Verify home circuit breaker is on and master reset is on (if equipped).
	Power outage.	Install new batteries in battery backup.
The remote displays the following message on -screen: Sorry your appliance did not start. Try again by pressing Flame On.	No power to appliance. No gas to appliance. Accumulation of air in gas line from extended period of appliance inactivity. Gas control system failure.	Verify that appliance has power and gas. Verify that the appliance accepts flame ON commands with an audible beep, and successfully turns flame on within 90 seconds. If this failure persists, contact dealer for service.

C. Troubleshooting

With proper installation, operation, and maintenance your gas appliance will provide years of trouble-free service. If you do experience a problem, this troubleshooting guide will assist a qualified service technician in the diagnosis of a problem and the corrective action to be taken. This troubleshooting guide can only be used by a qualified service technician. Contact your dealer to arrange a service call by a qualified service technician.

Note to Qualified Service Technician: Additional resources including troubleshooting guides and service videos are available through Hearth & Home Technologies. Contact your dealer or access resources through your myhht.com account.

IntelliFire Touch

Error Codes:

ECM LED Error Codes	Description
3 Red: 1 Green	IFT-RC400 error message: 'Appliance Safely Disabled', pilot sparks for 90 sec, no flame rectification.
2 Red: 1 Green	IFT-RC400 display: 'Error Pilot Flame', pilot valve solenoid not detected.
2 Red: 2 Green	Sparking feedback signal error, spark coil failure.
5 Red: 1 Green	IFT-RC400 display: 'Error Power Vent' (if installed).

See Troubleshooting matrix for more detail on Lock-out Error Codes, Possible Causes and Corrective Actions.

Troubleshooting:

Symptom	Possible Cause	Corrective Action
Pilot won't light, module clicks but no spark 90 sec, 3 Red/1 Green Lock out.	Incorrect wiring.	Verify 'S' (White) sense wire and 'I' (orange) ignitor wire are connected to correct terminals on IFT-ECM.
	Loose connections or electrical shorts in wiring.	Verify no loose connections or electrical shorts in wiring from module to pilot assembly. Verify wire insulation is not damaged. Verify wires are not grounding out to chassis, pilot burner, or any other metal object. Replace any damaged wires.
	Ignitor gap is too large.	Verify spark gap is approximately 0.095" (2.41 mm) to 0.135" (3.43 mm).
Pilot won't light, there is no noise or spark.	No AC power, AC/DC adaptor faulty, backup batteries (if being used) depleted, IFT-ECM slider switch in OFF position.	Verify IFT-ECM slider switch is in ON or REM position. Verify AC power available to junction box. Verify AC/DC adaptor is plugged into junction box and ECM. Verify AC/DC adaptor output voltage is between 5.7-6.3 Vdc. If battery pack is used, check battery pack voltage is >4.2 V (if not, replace batteries).
	Shorted or loose connection in system wiring or wiring harness.	Verify system wiring configuration. Remove and reinstall wiring harness that plugs into module. Check continuity of wires in valve wiring harness. Replace any damaged components.
	Poor or no system ground.	Verify black ground wire in valve harness is connected to metal chassis of fireplace.
Pilot won't light, there is no noise or spark, 2 Red/1 Green Lockout.	Pilot solenoid not detected.	Check if valve harness orange wire is connected to pilot solenoid valve. Check pilot solenoid resistance, nominal is 40 ohms. If open or shorted, replace valve. Check valve harness wire continuity, if open replace 6-pin harness.
Pilot won't light, there is no noise or spark, 2 Red/2 Green Lockout.	Spark coil failure.	Replace ECM.

IntelliFire Touch - (continued)

Symptom	Possible Cause	Corrective Action
Pilot sparks but does not light, after 90 sec, 3 Red/1 Green Lockout	No gas supply.	Verify incoming gas line ball valve is 'Open'. Verify inlet pressure is within requirement for gas type used. Contact gas supplier.
	ECM has poor ground.	Verify wiring, check valve harness black wire is securely grounded to metal chassis.
	Gas valve defective.	Check pilot valve solenoid kick and hold voltages during ignition cycle. Kick V should be >1 V, hold V minimum 0.26 V. If voltages are OK, replace gas valve.
Pilot lights but main burner does not light. Pilot continues to spark for 90 sec then goes into 3 Red/1 Green Lockout.	No flame detected. Flame rectification issue.	Check if white sense lead is securely connected to 'S' terminal of IFT-ECM. Check resistance of sense lead between sense rod tip and connector to IFT-ECM, should be less than 1 ohm - if not, replace pilot assembly. Check system ground, ensure black valve harness wire is securely attached to metal chassis. Check wiring for damage. With system OFF, check resistance between tip of sense rod and pilot hood, should be resistance (>1 M-ohm).
	No flame detected or sense rod contamination.	With glass assembly installed, verify pilot flame is engulfing flame sense rod on pilot assembly. Verify inlet gas pressure is correct for gas type. Polish flame sense rod with fine steel wool to remove any contaminants that may have accumulated.
Pilot lights and rectifies, but main burner does not light.	Main valve solenoid.	Check if green wire in valve harness is connected to green main valve solenoid. Check main valve solenoid resistance, nominal is 60 ohms. If open or shorted, replace valve. Verify valve inlet pressure is correct for gas type.
Pilot and main do not light, ECM goes into 5 Red/1 Green Lockout.	Power Vent (PV) Failure.	Power Vent blower defective - check wiring to IFT-ACM, check if blower is working. Check if PV pressure switch is connected to brown and black wire in 6-pin valve wire harness. Check if pressure switch is closed (shorted) when PV blower is running. Refer to PV troubleshooting instructions.
Appliance lights and runs for a few minutes then shuts down and/or appliance cycle ON and OFF with less than 90 sec of ON time.	Shorted or loose connection in flame detection circuit.	Check if white sense lead is securely connected to 'S' terminal of IFT-ECM. Check resistance of sense lead between sense rod tip and connector to IFT-ECM, should be less than 1 ohm - if not, replace pilot assembly. Check system ground, ensure black valve harness wire is securely attached to metal chassis. Check wiring for damage. With system OFF, check resistance between tip of sense rod and pilot hood, should be resistance (>1 M-ohm).
	Poor flame rectification or contaminated sense rod.	With glass assembly installed, verify pilot flame is engulfing flame sense rod on pilot assembly. Verify inlet gas pressure is correct for gas type. Polish flame sense rod with fine steel wool to remove any contaminants that may have accumulated. Verify no soot deposits are in sense rod to pilot hood gap.
	Logs are set up wrong.	Remove and re-install logs per the log placement instructions.
	Damaged pilot assembly.	Verify the pilot assembly ceramic insulator around the flame sensing rod is not cracked, damaged or loose. Check resistance between tip of sense rod and IFT-ECM connector, should be less than 1 ohm. Replace pilot assembly if damage is detected.

6 Reference Materials

A. Accessories

Install approved accessories per instructions included with accessories.

Contact your dealer for a list of approved accessories.

WARNING! Risk of Fire and Electric Shock! Use *ONLY* Hearth & Home Technologies-approved optional accessories with this appliance. Using non-listed accessories could result in a safety hazard and will void the warranty.

Remote Controls, Wall Controls and Wall Switches

After a qualified service technician has installed the remote control, wall control or wall switch, follow the instructions supplied with the control installed to operate your fireplace:

For safety:

- Install a switch lock or a wall/remote control with child protection lockout feature.
- Keep remote controls out of reach of children.

See your dealer if you have questions.

Required Decorative Barrier Front, Surrounds

This appliance requires a Surround/Decorative Barrier Front. For available options, consult your dealer.

WARNING! Risk of Fire! Install *ONLY* doors or fronts approved by Hearth & Home Technologies. Unapproved doors or fronts may cause fireplace to overheat.

This fireplace has been supplied with an integral barrier to prevent direct contact with the fixed glass panel. DO NOT operate the fireplace with the barrier removed.

Contact your dealer or Hearth & Home Technologies if the barrier is not present or help is needed to properly install one.

For more information refer to the instructions supplied with your decorative barrier front.



B. Service Parts

TRILLIANT25IN, TRILLIANT25IL

25" Gas Insert - DV

IN Beginning Manufacturing Date: Jun 2023

IL Beginning Manufacturing Date: July 2024

Ending Manufacturing Date: Active

Log Set Assembly

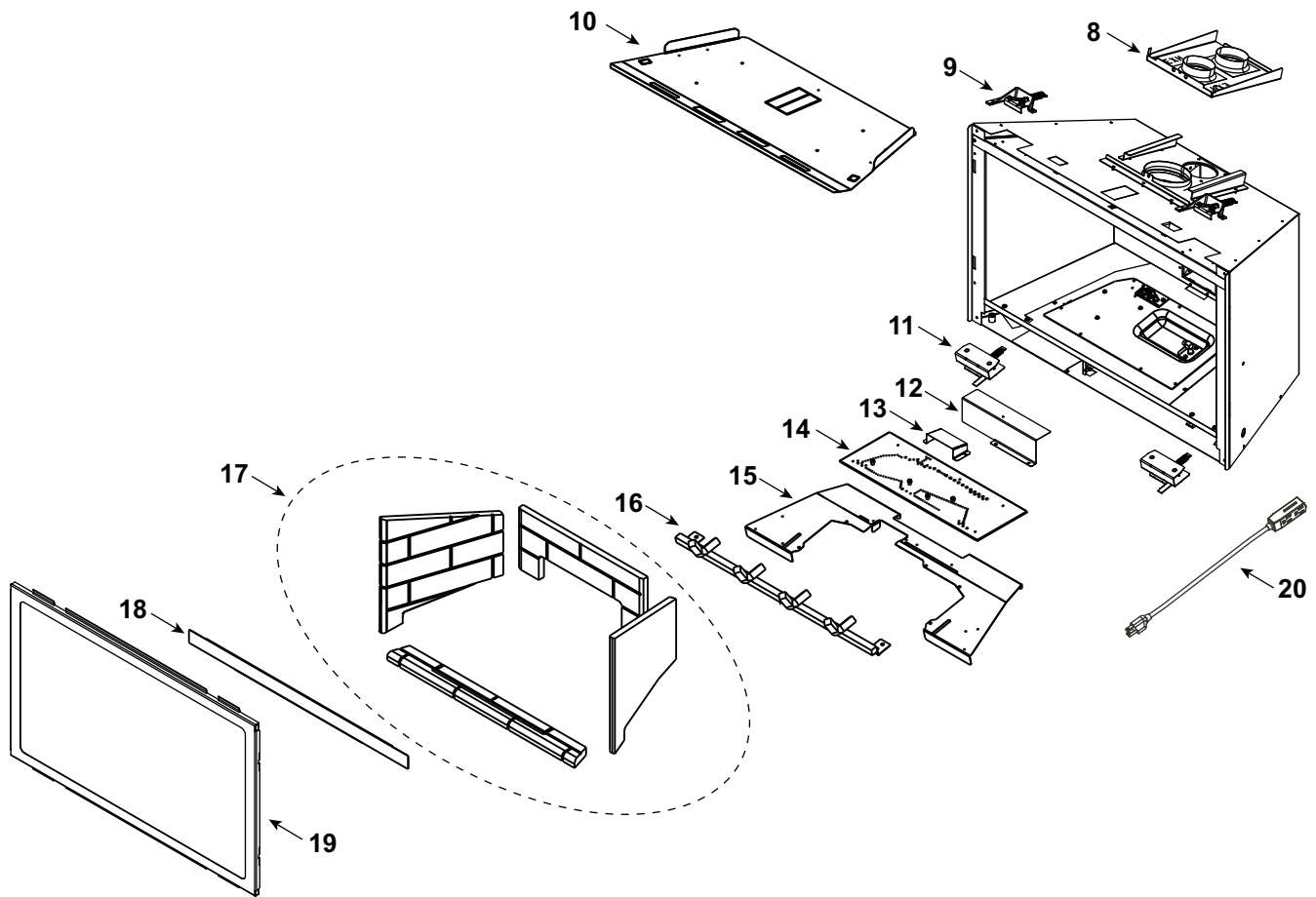
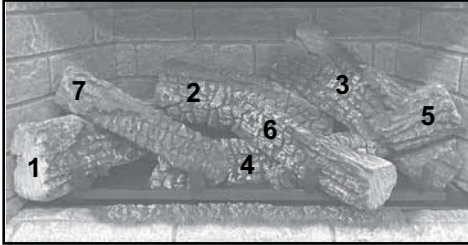

Part number list on following page.



IMPORTANT: THIS IS DATED INFORMATION. Parts must be ordered from a dealer or distributor. **Hearth and Home Technologies does not sell directly to consumers.** Provide model number and serial number when requesting service parts from your dealer or distributor.



Stocked at Depot

ITEM	DESCRIPTION	COMMENTS	PART NUMBER	
	Log Assembly (Hearth Refractory not Included)		LOGS-2537	Y
1	Log 1		SRV2537-711	
2	Log 2		SRV2537-712	
3	Log 3		SRV2537-713	
4	Log 4		SRV2538-714	
5	Log 5		SRV2537-716	
6	Log 6		SRV2537-717	
7	Log 7		SRV2537-715	
8	Slide Plate Assembly		2532-014	
	Tool, Slide Plate (Multi-purpose)		2532-140	
	Gasket		2532-113	
9	Glass Clip Assembly, Top	Qty 2 req	2155-046	
10	Baffle, Firebox		2531-138	
11	Glass Clip Assembly, Bottom	Qty 2 req	2532-009	
12	Air Scoop		2532-135	
13	Pilot Shield		2532-153	
14	Burner Assembly		2537-007	Y
15	Base Pan		2537-130	
16	Grate		SRV2537-014	
17	Refractory Assembly		SRV2537-076	
	Hearth Refractory		SRV2537-703	
18	Seal, Glass Frame		2531-122	
19	Glass Door Assembly		GLA-2531	Y
20	Power Cord		2201-024	Y
	Fan		GFK-160A	Y

Additional service part numbers appear on following page.



Log Set Assembly

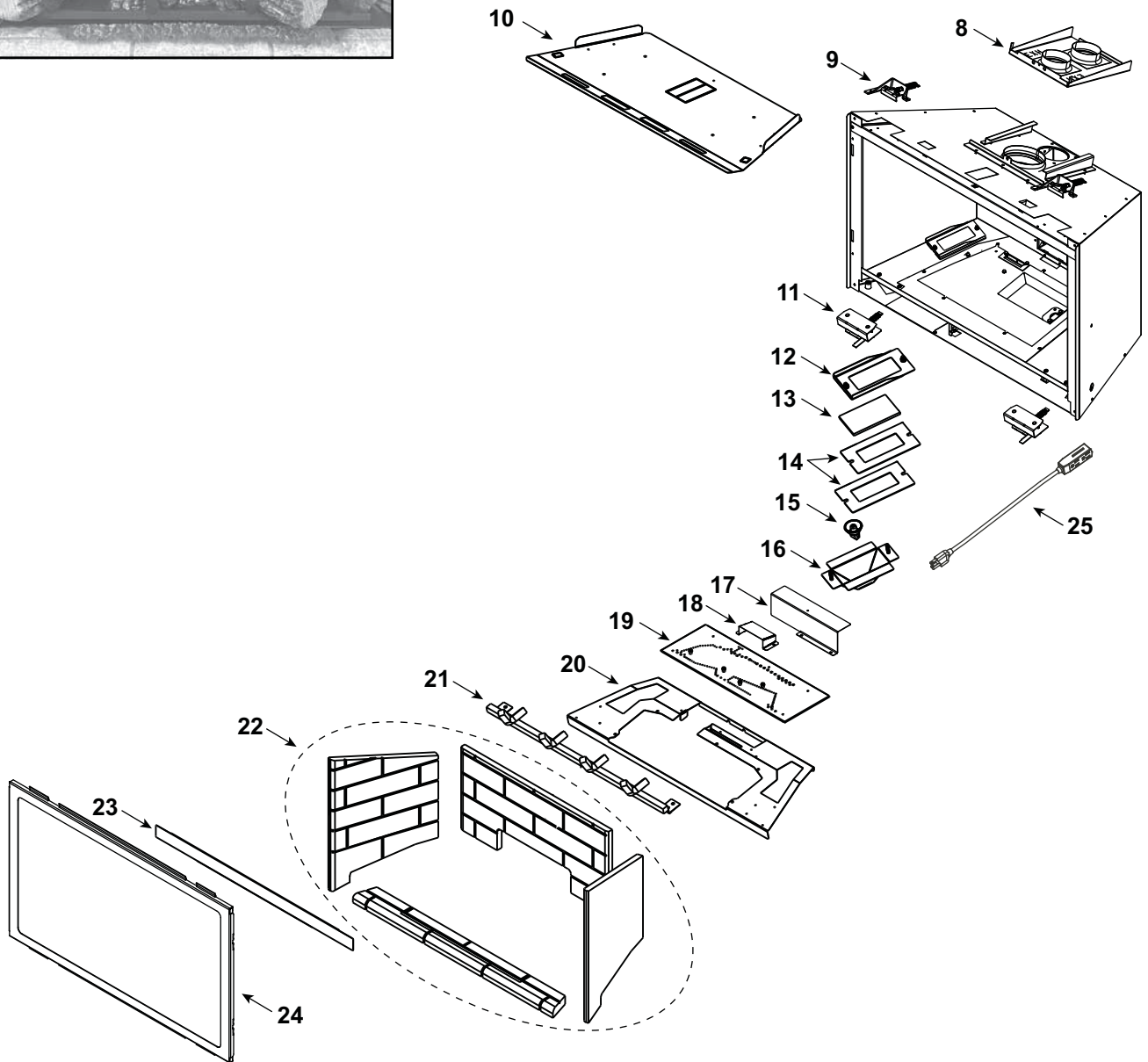
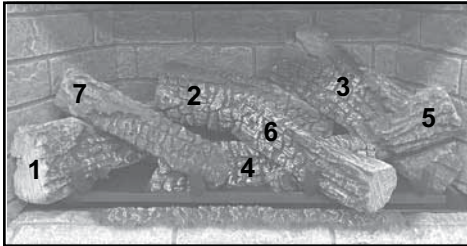



Service Parts

TRILLIANT30IN, TRILLIANT30IL

IN Beginning Manufacturing Date: Jun 2023
 IL Beginning Manufacturing Date: July 2024
 Ending Manufacturing Date: Active

IMPORTANT: THIS IS DATED INFORMATION. Parts must be ordered from a dealer or distributor. **Hearth and Home Technologies does not sell directly to consumers.** Provide model number and serial number when requesting service parts from your dealer or distributor.



Stocked at Depot

ITEM	DESCRIPTION	COMMENTS	PART NUMBER	
	Log Assembly (Hearth Refractory not Included)		LOGS-2538	Y
1	Log 1		SRV2538-711	
2	Log 2		SRV2538-712	
3	Log 3		SRV2538-713	
4	Log 4		SRV2538-714	
5	Log 5		SRV2538-716	
6	Log 6		SRV2538-717	
7	Log 7		SRV2538-715	
8	Slide Plate Assembly		2532-014	
	Tool, Slide Plate (Multi-purpose)		2532-140	
	Gasket		2532-113	
9	Glass Clip Assembly, Top	Qty 2 req	2155-046	
10	Baffle, Firebox		2532-138	
11	Glass Clip Assembly, Bottom	Qty 2 req	2532-009	
12	Light Glass, Hold Down	Qty 2 req	2532-149	
13	Accent Glass	Qty 2 req	2532-151	
14	Light Glass Gasket	Qty 4 req	2532-150	
15	Halogen Reflector Lamp, 50W	Qty 2 req	2201-150	Y
16	Light Tub Assembly	Qty 2 req	2532-006	
	Light Wire Assembly		2532-017	Y
17	Air Scoop		2532-135	
18	Pilot Shield		2532-153	
19	Burner Assembly		2538-007	Y
20	Base Pan		2538-130	
21	Grate		SRV2538-014	
22	Refractory Assembly		SRV2538-076	
	Hearth, Refractory		SRV2538-703	
23	Seal, Glass Frame		2532-122	
24	Glass Door Assembly		GLA-2532	Y
25	Power Cord		2201-024	Y
	Fan		GFK-160A	Y

Additional service part numbers appear on following page.



Log Set Assembly

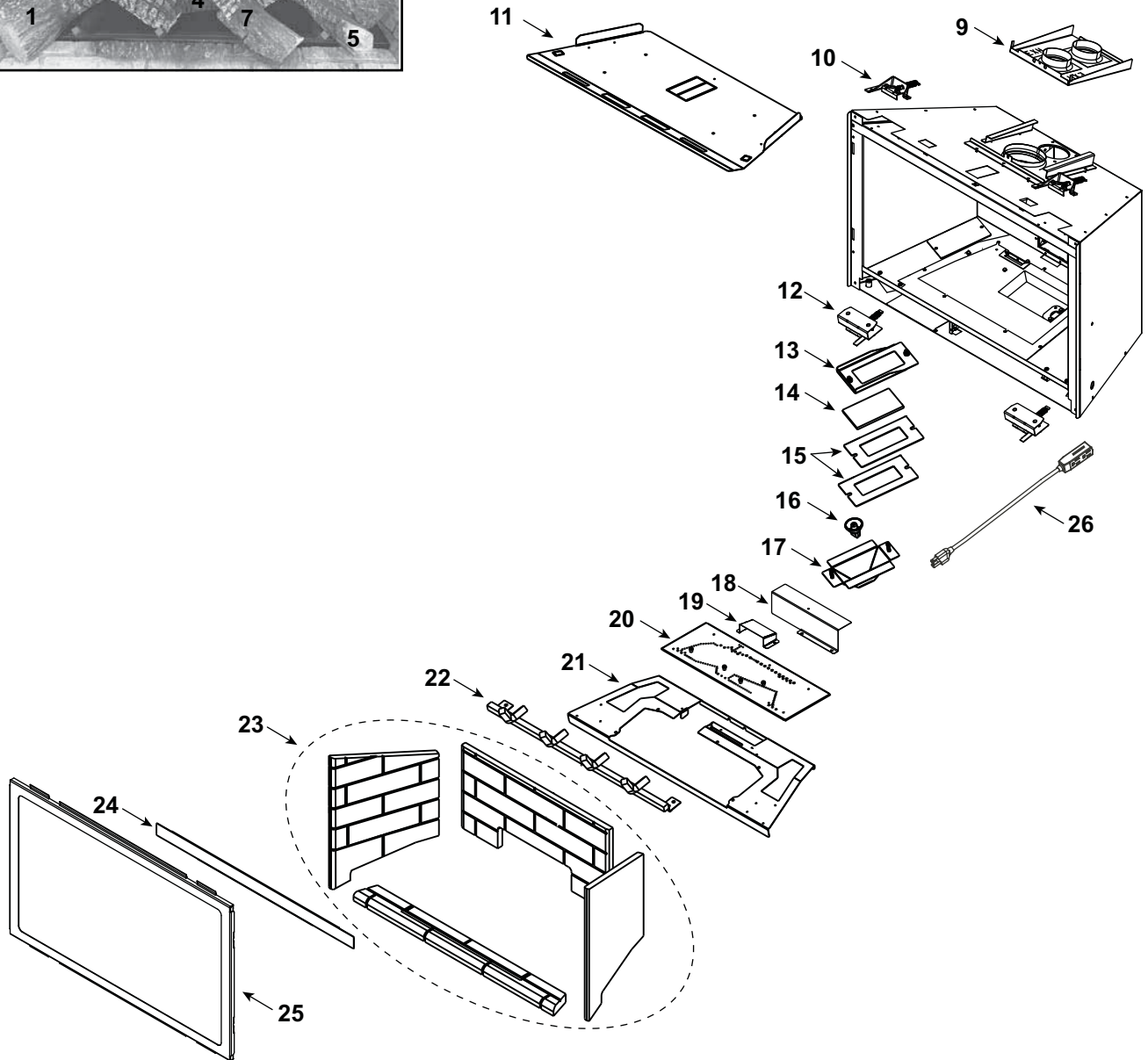
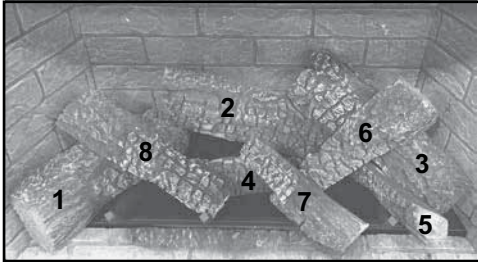



Service Parts

TRILLIANT35IN, TRILLIANT35IL

IN Beginning Manufacturing Date: Jun 2023
 IL Beginning Manufacturing Date: July 2024
 Ending Manufacturing Date: Active

IMPORTANT: THIS IS DATED INFORMATION. Parts must be ordered from a dealer or distributor. **Hearth and Home Technologies does not sell directly to consumers.** Provide model number and serial number when requesting service parts from your dealer or distributor.



**Stocked
at Depot**

ITEM	DESCRIPTION	COMMENTS	PART NUMBER	
	Log Assembly (Hearth Refractory not Included)		LOGS-2539	Y
1	Log 1		SRV2539-711	
2	Log 2		SRV2539-712	
3	Log 3		SRV2539-713	
4	Log 4		SRV2539-714	
5	Log 5		SRV2538-715	
6	Log 6		SRV2539-716	
7	Log 7		SRV2538-717	
8	Log 8		SRV2539-718	
9	Slide Plate Assembly		2532-014	
	Tool, Slide Plate (Multi-purpose)		2532-140	
	Gasket		2532-113	
10	Glass Clip Assembly, Top	Qty 2 req	2155-046	
11	Baffle, Firebox		2533-138	
12	Glass Clip Assembly, Bottom	Qty 2 req	2532-009	
13	Light Glass, Hold Down	Qty 2 req	2532-149	
14	Accent Glass	Qty 2 req	2532-151	
15	Light Glass Gasket	Qty 4 req	2532-150	
16	Halogen Reflector Lamp, 50W	Qty 2 req	2201-150	Y
17	Light Tub Assembly	Qty 2 req	2532-006	
	Light Wire Assembly		2532-017	Y
18	Air Scoop		2532-135	
19	Pilot Shield		2532-153	
20	Burner Assembly		2539-007	Y
21	Base Pan		2539-130	
22	Grate		SRV2538-014	
23	Refractory Assembly		SRV2539-076	
	Hearth, Refractory		SRV2539-703	
24	Seal, Glass Frame		2533-122	
25	Glass Door Assembly		GLA-2533	Y
26	Power Cord		2201-024	Y
	Fan		GFK-160A	Y

Additional service part numbers appear on following page.



IN Beginning Manufacturing Date: Jun 2023
 IL Beginning Manufacturing Date: July 2024
 Ending Manufacturing Date: Active

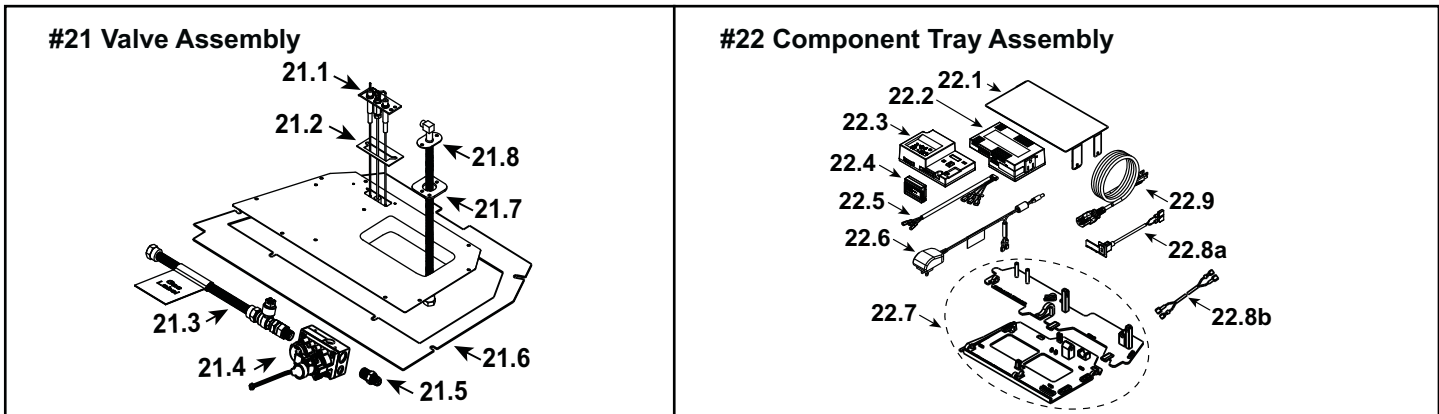

IMPORTANT: THIS IS DATED INFORMATION. Parts must be ordered from a dealer or distributor. **Hearth and Home Technologies does not sell directly to consumers.** Provide model number and serial number when requesting service parts from your dealer or distributor.



Stocked at Depot

ITEM	DESCRIPTION	COMMENTS	PART NUMBER	Stocked at Depot
21.1	Pilot Assembly NG		2550-013	Y
	Pilot Assembly Propane		2550-014	Y
21.2	Pilot Gasket		2532-134	
21.3	Flex Ball Valve Assembly		2532-081	Y
21.4	Valve NG		SRV2166-302	Y
	Valve Propane		2166-303	Y
21.5	Male Connector	Pkg of 5	303-315/5	Y
21.6	Gasket, Valve Plate		2532-131	
21.7	Gasket, Bulkhead		438-407	
21.8	Bulkhead w/Flex Tube		SRV7000-156	Y
	Orifice NG (#40C)	Trilliant25	582-840	Y
	Orifice Propane (#53C)		582-853	Y
	Orifice NG (#35C)	Trilliant30	SRV582-835	Y
	Orifice Propane (#51C)		SRV582-851	Y
	Orifice NG (#33C)	Trilliant35	582-833	Y
	Orifice Propane (#50C)		582-850	Y
22.1	Component Heat Shield		2532-144	Y
22.2	Module, B Type AC		SRV2326-150	Y
22.3	Module, IFT Control		SRV2326-130	Y
22.4	Module, RF FCC		SRV2326-120	Y
22.5	Harness, IFT 6 Pin Wiring		SRV2326-132	Y
22.6	6 Volt DC Power Adapter		2326-191	Y
22.7	Tray, Component & Wire		2532-172	Y
22.8a	Assembly, USB-C Bracket	SN Range LC5673022 - LC6494692	2532-301	Y
22.8b	40" Wire Harness	Post LC6494692	SRV2531-140	Y
22.9	Cable, B Type AC Module		SRV2326-152	Y

Additional service part numbers appear on following page.



IN Beginning Manufacturing Date: Jun 2023
 IL Beginning Manufacturing Date: July 2024
 Ending Manufacturing Date: Active

IMPORTANT: THIS IS DATED INFORMATION. Parts must be ordered from a dealer or distributor. **Hearth and Home Technologies does not sell directly to consumers.** Provide model number and serial number when requesting service parts from your dealer or distributor.



Stocked
at Depot

ITEM	DESCRIPTION	COMMENTS	PART NUMBER	Stocked at Depot
	Battery Pack**		SRV2326-142	Y
	Bolt, Level Leg	Qty 4 req	2073-162/24	Y
	Ember Rocks	Trilliant30 Trilliant35	2201-853	
	Fan Dampener		SRV2532-686	
	Back Cover Plate (Fan Access)		SRV2532-166	
	Mineral Wool		050-721	
	RC400 Remote		SRV2326-110	Y
	Screw, Bottom Glass Clip	Qty 4 req	419-802/24	Y
	Touch up Paint		TUP-GBK-12	Y
	Vermiculite Embers		MYSTIC-EMBERS	
Conversion Kits				
	Conversion Kit NG		NGK-MI-IFT	Y
	Conversion Kit Propane		LPK-MI-IFT	Y
	Pilot Orifice NG		SRV593-528	Y
	Pilot Orifice Propane		593-526	Y
	Regulator NG		NGK-DXV-50	Y
	Regulator Propane		SRVLPK-DXV-50	Y

**Fuse for battery pack can be sourced locally, not a warranty item. Specs are 250v, 3A fuse, 3/4" long



C. Contact Information



Majestic, a brand of Hearth & Home Technologies
7571 215th Street West, Lakeville, MN 55044
www.majesticproducts.com

Please contact your Majestic dealer with any questions or concerns.
For the location of your nearest Majestic dealer,
please visit www.majesticproducts.com.

- NOTES -

NOTICE		
	DO NOT DISCARD THIS MANUAL	
<ul style="list-style-type: none">• Important operating and maintenance instructions included.	<ul style="list-style-type: none">• Read, understand and follow these instructions for safe installation and operation.	<ul style="list-style-type: none">• Leave this manual with party responsible for use and operation.

This product may be covered by one or more of the following patents: (United States) 7077122, 7074035, 7234932, 7322819, 7422011, 7726300, 8147240, 9625149 or other U.S. and foreign patents pending.

2000-945F

Printed in U.S.A. - Copyright 2024