

MAGNUM WINCHESTER

Corn/Biomass/Wood Pellet Stove

Models: WINACP, WINACI, WINDCI, WINDCP

Owner's Manual

Installation – Operation – Maintenance Instructions

NOTE: THESE INSTRUCTIONS MUST BE SAVED for future reference

PLEASE READ THIS ENTIRE MANUAL BEFORE INSTALLATION AND USE OF THIS PELLET BURNING STOVE. FAILURE TO FOLLOW THESE INSTRUCTIONS MAY RESULT IN PROPERTY DAMAGE, BODILY INJURY OR EVEN DEATH.

IMPORTANT: Always contact your local Magnum dealer/installer with questions before contacting the factory. When you call, have your serial number, purchase date, who installed the unit and a list of questions.

- ✓ When installing your **MagnuM Winchester (WIN) Corn/Biomass/Wood Pellet** stove, particular attention needs to be made in regards to fire protection. If the unit is not properly installed, a house fire may result. For your safety, follow the installation and operation instructions provided, and if a question arises contact local building or fire officials about restrictions and installation requirements in your area.
- ✓ Read the operations and fuel section of this manual before plugging in your unit.
- ✓ Always unplug the unit before attempting any service work.
- ✓ Do not connect the unit to a chimney flue already serving another appliance.
- ✓ When installing the chimney pipe to the unit, it is important to remember that the unit operates on a negative pressure and the chimney on a positive pressure. All chimney connections, elbows and fittings must be airtight. **(Proper venting practices must be followed. Consult with a venting professional)**
- ✓ Ashes must be disposed of in a metal container with a tight fitting lid.
- ✓ All minimum clearances to combustibles must be followed.
- ✓ The **MagnuM Corn/Biomass/Wood Pellet Stove** is tested for operation with wood pellets, with an ash content of no more than 2% and Corn with a moisture content from 10-14 percent. **It is recommended that wood pellets with an ash content of 1% or less be used for efficient operation of this unit. Higher ash content fuels will require additional maintenance and service. Also, for use with wood pellets, cherry pits, olive pits or other pelletized Biomass fuel. Corn with 11-12 percent moisture is ideal.**
- ✓ **It is important to use fuel that is clean, dry and consistent.** Make sure that your supplier is giving you the same fuel each time that you purchase. It is recommended that you purchase your entire heating season supply of fuel at one time so that the fuel will be the same.
- ✓ **A voltage surge protector or ground fault outlet is required for this unit. The electrical component warranty will be voided if surge protection is not installed before operating this unit.**
- ✓ **A grounded outlet must be provided with proper polarity. A constant 115 volt (12volt on DC models), 60 cycles must be provided for proper operation or the warranty of this appliance will be forfeited.**
- ✓ **Special attention needs to be taken to clean out the top heat exchangers of this unit on a regular basis. The fly ash settles on the heat exchangers and must be cleaned off to keep the unit operating properly. Check for plugging every two-four weeks or when needed.**
- ✓ **If unit is not operated for extended periods of time (like summer) unplug the unit and disconnect the battery to assure long life of electrical components.**

AMERICAN ENERGY SYSTEMS, INC. GRANTS NO WARRANTY, IMPLIED OR STATED, FOR THE INSTALLATION OR MAINTENANCE OF THE STOVE AND ASSUMES NO RESPONSIBILITY FOR ANY CONSEQUENTIAL DAMAGE(S).

AMERICAN ENERGY SYSTEMS, INC. - 150 Michigan Street SE - HUTCHINSON, MINNESOTA 55350

Web Site: www.MagnuMheat.com

<u>SECTION</u>	<u>PAGE</u>
Introduction/Specifications.....	3
Technical Bulletin/Importance of Adequate Fresh Air.....	4
Safety Steps.....	5
Burning Solid Fuels.....	6, 7
Unpacking Your Magnum Wood Pellet Appliance	7, 8
Clearances.....	9
Guidelines for Exhaust Venting Systems Design.....	10, 11
Design Guidelines for Outside Combustion Air Connection.....	12
Installation Precautions.....	13
Installation Configurations.....	14
Vent Termination General Instructions.....	15
Horizontal Installation.....	16
Vertical Installation.....	17, 18
AC/DC Control Panel/Thermostat Hook-up.....	19, 20
Magnum WIN Insert Installation	21, 22, 23
Installation Instructions.....	24, 25, 26
Control Panel/Thermostat Hook-up.....	27
Optional 12 Volt Battery Back-up.....	28
Operating Instructions AC/DC/All Models.....	29, 30, 31
Cleaning Instructions.....	32, 33
Cleaning Instructions for the Winchester Insert.....	34, 35
Automatic Features.....	36
Glass Maintenance, Adjustment, Removal and Replacement.....	37
Circuit Board Functions.....	38, 39
Setting the Draft.....	40
Wiring Diagram AC/DC.....	41, 42
Draft Slide Gate Adjustment.....	43
Solar Panel Connections.....	43
Igniter Replacement.....	44
Trouble Shoot Guide.....	45, 46, 47, 48
Magnum Winchester Replacement Parts List.....	49
Warranty.....	50
Service Record.....	51

TESTING/CERTIFICATION INFORMATION

The Magnum WIN stove (report # 150-S-01b-4) independently tested in accordance with ASTM E1509

The Magnum WIN Insert (report # 097-S-04-2) independently tested in accordance with ASTM E1509

Tested with OMNI-Test Laboratories, Inc, BEAVERTON, OREGON 97005

per EPA Method 28A, ULC C1482-M1990, CAN/ULC-S627-00, ULC-S628, APFI req.

The pellet fired appliance has been tested and listed for use in manufactured homes in accordance with

Oregon

Administrative Rules 814-23-900 through 814-23-909 (UM) 84-HUD

SERIAL # _____ DATE PURCHASED _____

READ THIS MANUAL THOROUGHLY BEFORE INSTALLING THIS UNIT AND KEEP THIS
MANUAL IN A HANDY PLACE FOR FUTURE REFERENCE.

DEAR VALUED MAGNUM PRODUCT OWNER,

We appreciate your decision to help preserve our precious environment by purchasing your **MagnuM Corn/Biomass/Wood Pellet Appliance**. With everyone working together, we can have clean air and renewable heat for our homes.

Please read this Owners Manual carefully before using this appliance and if you have any questions contact your local **MagnuM** dealer. We appreciate your business and wish you many warm days and nights with your new **MagnuM Corn/Biomass/Wood Pellet Appliance**.

Sincerely,
Mike Haefner, President
American Energy Systems, Inc.

P.S. You are very important to the success of our business and your referral of our products is very much appreciated. Many of our Resellers have referral rewards available and I encourage you to ask your local dealer how to get involved in helping make our country energy self-sufficient. **GOOD LUCK!**

SPECIFICATIONS

American Energy Systems, Inc., manufacturer of the **MagnuM Winchester Appliances**, reserves the right to alter its products, their specifications and/or price without notice.

Safety tested and EPA exemption tested by Omni to UL 1482, CAN/ULC-S627, ULC-S628, APFI requirements, Oregon administrative rules 814-23-900 to 814-23-909 and E.P.A. Method 28A.

	Winchester	Insert
Heating range	8,000- 40,000 BTU	
Fuel Storage Capacity	Up to 68 Lbs.	Up to 60 Lbs.
Width	24"	23 1/2"
Height	33"ped, 40"leg,	21 1/2"Insert
Depth	22"	21 1/2"

	CLEARANCE TO COMBUSTIBLES, Stoves Insert clearance to combustibles are on pages 21-24
	Vertical Termination w/3" Pellet Vent
Back Wall	3" (75mm)
Side	3" (75mm)
Corner	3" (75mm)
Flue to Wall	3" (75mm)
Floor Protection	6" (150mm) out in front of unit 6" to sides

BTU input will vary, depending on the brand of fuel, size of fuel, quality of fuel and moisture content. Consult your authorized MagnuM reseller for information on the best fuel to use to get the best results. Fuel feed rates can vary as much as 50 percent depending on fuel quality, size, brand and moisture content.

Technical Bulletin

Importance of Adequate Fresh Air

Every home is a slightly different situation and depending on the design of the air movement within the home, might be easy to distribute heat or very difficult. If you have boiler heat or other non-ducted central heating this becomes even more of a challenge as adequate circulation within the home and proper make up air for combustion is lacking because of the design of your central heating system.

When a forced-air system is put into a home that is not designed with proper circulatory patterns, it might be necessary to add return air ducts or at least vents to get the air moving around the home. Fresh air for the home and fresh air for combustion will have to be added or the stove or furnace will burn dirty and efficiency will suffer.

Your dealer needs to assess the fresh air requirements for the home. At a minimum, there should be a 6" or larger (this should be determined by figuring what the home requires) fresh air vent coming in to a neutral part of the home to make sure that there is adequate fresh air to the home. Then the 3" make up air to the unit is required to be provided.

If the wood pellets are not burning correctly you need to address a few things. Are the wood pellets wet or dirty? If they are, make sure that your wood pellets are cleaned (we have an excellent "E-SIFTER" product that will do a great job) and below 15 percent moisture. 3-4 percent moisture is ideal.

The most common cause of wood pellets not burning properly is contaminated air or negative pressure in the home. It can be as simple as the air adjustment not set properly on the side of the stove or it could be that there is a serious lacking of good quality air in the home caused by negative pressure. If you have done any remodeling or if this is a newer home, it is a very real possibility that this is happening. Most basements have negative pressure even if you feel that your home is drafty. This is called the stack or chimney effect.

If there is a black coating of soot coming into the home it is caused by the reversal of the exhaust that would normally exit the stove outside being drawn into the home by negative pressure or improperly installed venting. Depending on your venting configuration this could be aggravated by back drafts, high wind and cold chimneys.

Sometimes this also occurs if there is an intake for fresh air too close to the exhaust on the outside of the home or other conditions causing the exhaust to be pulled back into the home.

The first indications of negative pressure affecting the stove occurs app. 3 days after the stove is lit. The glass gets dirty very easy, the firepot might keep filling up even though you pull the air adjustment out, and you notice that the venting fills up with soot rapidly. After a few days, the exhaust can no longer adequately pull out all of the fly ash so it reverses and is pulled into the home. This might happen through the venting if it is not sealed properly or it might come out when you open the door for maintenance and also backwards through the air wash system.

This can be easily corrected by adding the fresh air for the home and also for the appliance. It is imperative that you would have your dealer or installer check the unit out for proper operation to make sure that there is nothing mechanical wrong with the appliance and then determine your need for proper fresh air. Your dealer can contact the factory with any questions that he might have.

SAFETY STEPS

IMPORTANT: Proper installation of this stove is crucial for proper and safe operation. Installing this product improperly may result in a house fire and/or personal injury. All applicable building codes for your location must be followed. In areas where building codes require additional steps to the installation of this product not included in this manual, the building codes will take precedent and must be followed. Contact your local building inspector to obtain any necessary permits or inspection guidelines before installing the product. **(This appliance must be installed by a trained professional installer to assure proper installation and warranty of this product) Warranty labor, parts failing due to improper installation and shipping will not be covered if the unit is not installed by a trained installer.**

- ✓ **DISCONNECT THE POWER CORD BEFORE SERVICING THIS STOVE! A power surge protector is required.** The unit must be plugged in to a **grounded** 110 volt 60 Hz or a 12V DC sealed battery power source. NEVER use an “unsealed” type battery, nor operate unit on a battery without a 12 volt 4 ampere in-line fuse on a positive line.
- ✓ Always route the power cord away from the unit. Do not route cord in foot traffic areas. Do not pinch cord under furniture. Do not add any additional length to the power cord.
- ✓ This product requires simple periodic maintenance for proper operation and long life of the stove. Read and follow the maintenance schedule closely. **Do not operate with the doors or hopper open.**
- ✓ **The Magnum Winchester stove models are designed, approved and tested to burn corn/wood pellets and other Biomass fuels.** The burning of other solid fuels such as cord wood in this stove is not permitted. If you are burning fuels not approved for this appliance it will void the warranty and no service/warranty will be allowed.
- ✓ The Magnum models will burn high ash content fuels but will require additional maintenance/cleaning.
- ✓ A working smoke detector must be installed in the same room as this product.
- ✓ It is recommended that a fire extinguisher “class a-b-c” be installed close to the appliance.
- ✓ Flammable or explosive liquids such as gasoline, naphtha or engine oil must NEVER be used in or around this stove. These liquids must be stored well away from this stove as the open flame in the burn chamber could ignite the fumes of such liquids. **Do not burn garbage in this unit.**
- ✓ According to HUD requirements, when installed in a mobile home, this stove must be grounded directly to the steel chassis of the mobile home and bolted to the floor.
- ✓ This stove is not intended for use in commercial installations but can be used.
- ✓ The moving parts of this stove are propelled by high torque electric motors. The auger can cause severe injury to body parts that may get near them. Keep all body parts away from the auger while the stove is plugged into an electrical outlet. These moving parts may begin moving at any time while the stove is plugged in.
- ✓ This unit must be installed on a non-combustible surface. Make sure that the unit is level.
- ✓ Do not attempt internal service to the unit when it is burning and or plugged into power.
- ✓ It is a good idea to burn the unit outside for a couple hours before installation to burn off any paint or oil fumes. (Most resellers pre-burn the unit before you receive them, do not worry if your unit looks like it has been burnt.)

IMPORTANT: It is the customer’s responsibility to make sure the Magnum appliance is installed with the proper make up air system and the home is checked for adequate fresh air so that the appliance does not become the fresh air source for the home.

BURNING SOLID FUELS (shelled corn and wood pellets)

Unlike petroleum and natural gas products, solid fuels such as wood pellets create ash as the fuel is burned. Even with the highly efficient flame your **MagnuM** stove will produce, the solid fuels used will produce ash. This ash will have to be cleaned out of the stove from time to time. The cleaning procedure will be discussed later in this manual. You can minimize the amount of cleaning required and maximize the efficiency of your stove by maintaining the correct draft settings.

The draft setting on your stove may have to be changed from time to time to accommodate your specific burning conditions. Proper draft setting will be discussed later in this manual. The point we wish to make here is that your **MagnuM** stove, due to the nature of solid fuels, will require brief periodic attention. Please do not expect to light your stove and walk away from it until you want to shut it off in the spring. A few moments of adjustment and cleaning from time to time is an important part of burning solid fuels.

The **MagnuM** stove has been designed to burn wood pellets that meet the Association of Pellet Fuel Industries standards. Since these fuels vary greatly in quality and consistency, AES cannot be responsible for damage done to your stove due to fuel problems. The following are guidelines to using and selecting proper fuels for your stove.

SHELLED CORN (11-12 percent moisture recommended)

- ✓ Store your corn supply in a dry place and keep the bags or containers sealed to prevent your corn from absorbing excess moisture. Test the moisture content periodically to maintain the proper dryness.
- ✓ **Check your corn for foreign objects. Your stove warranty will not cover damage done to your stove due to foreign objects in the fuel supply.**
- ✓ **Do not carry your corn supply over into the next heating season if possible unless properly stored.** If you carry over your corn supply make sure to check the corn for proper moisture content.
- ✓ **DO NOT BURN “TREATED” SEED CORN IN YOUR STOVE.** Seed corn is treated with chemical pesticides that are harmful or fatal if swallowed; therefore, seed corn is dangerous to have in the house, especially where children can reach it. **Burning treated seed corn in your stove will void the warranty and will destroy the exhaust system on the unit.**
- ✓ **Corn must be 14% or less moisture content.** Wet corn will cause rapid plugging and deterioration of the stove and exhaust system, lower the heat output and will void the product warranty.
- ✓ Corn must be cleaned and free from debris. Corn right from the field will often have stalks, sticks, bolts and cob debris, which can plug the auger and/or cause damage to the auger and motor. Damage caused by dirty corn and other foreign objects are not covered by the product warranty. Ask for clean corn when you purchase it from your local corn supplier. Clean corn can be purchased in bulk or bagged from most elevators, feed stores or even your local farmer.

ALWAYS ASK FOR CORN WITH 11-12% MOISTURE CONTENT.

- ✓ **If you are having trouble finding clean Corn, contact your local MagnuM Dealer and ask them to get you an “Energy Sifter” corn cleaning system.** Cleaning your corn with the Energy Sifter from American Energy Systems will assure clean corn and a more consistent burn rate. It is also important to vacuum out your hopper once a month to assure trouble free auguring of the corn.

- ✓ There are many varieties of corn grown around the world. Each variety has unique characteristics including the shape and size of the kernel. Your stove will burn more consistently with a small to mid-size kernel corn. If the kernel size of the corn varies greatly or if you switch sources frequently, you will get a less consistent burn, which will require more attention to the draft setting on your stove. Therefore, purchasing corn from the same source will help achieve a more consistent burn. **DO NOT USE CORN WITH A HIGH WAX CONTENT!**

WOOD PELLETS

- ✓ Be consistent in your wood pellet fuel supplier. Wood pellets will vary in content and burn characteristics from supplier to supplier. A consistent supply of wood pellets will require fewer adjustments to the draft of the stove.
- ✓ Check your wood pellets for foreign objects. Your stove warranty will not cover damage done to your stove due to foreign objects in the fuel supply.
- ✓ Store your wood pellets in a dry place to prevent them from absorbing excess moisture.
- ✓ Vacuum the hopper out after every 6-7 bags to eliminate buildup of sawdust. More often if the wood pellets are poor quality. If sawdust is a problem you will have to screen each bag of fuel for a consistent feed.
- ✓ Wood pellets vary from supplier to supplier in ash content from less than 1% to 3% or more. Low ash content pellets will allow you to burn the stove longer between cleanings. Only wood pellets manufactured to the Association of Pellet Fuel Industries (A.P.F.I.) standard for residential pellet fuels are recommended. Look for A.P.F.I. registration number on the back of pellets. Consult your local **MagnuM** reseller for more information on approved wood pellet fuel.
- ✓ It is strongly recommended not to keep a supply of wood pellets over the summer months. Moisture will build up and cause problems in the fall with your appliance operation. Make sure that your supplier is not selling you left over fuel or fuel that has been out in the rain.

UNPACKING YOUR MAGNUM CORN/BIOMASS/WOOD PELLET UNIT

When you receive your MagnuM Corn/Biomass/Wood Pellet Stove, Pedestal unit, Leg unit or Fireplace Insert, be careful to inspect all parts and components to make sure that nothing was damaged or lost in shipment. If there was shipping damage, be sure to report it to your MagnuM reseller, or the shipping company that delivered your unit. Freight damage claims must be made to the Freight Company immediately. If parts are missing contact your local MagnuM reseller or contact the factory right away. Your satisfaction is our top priority.

To uncrate your **MagnuM** appliance:

- 1) Cut the banding straps and open the carton lid. The carton is stapled to the wood pallet so it will be necessary to pull the cardboard loose from the pallet. Remove the crating box carefully lifting up over the top of the unit. Be careful not to scratch the unit with the staples. Remove the wood blocks and plastic. We strongly urge you to recycle the packaging materials to help protect the environment.

The Pedestal unit comes completely assembled, the Insert comes with the shroud packaged separately and the Leg unit comes with the legs packaged in the hopper.

The installation of the Insert shroud is shown later in the installation manual. Make sure that the shroud is with the unit when you get it.

The following diagram will show how to install the legs on the Leg Unit. The legs are wrapped up and packaged in the hopper. Unpack the legs and get the four (4) nuts out of the hardware bag.

Tip the unit back so that you can get the leg onto the bolt that is sticking down in each corner of the bottom of the base. Be sure to have someone helping hold the unit while you are attaching the leg. The casting could break if bound or dropped.

NOTE: It is best to attach the legs on one side first and then lift the unit up level to attach the other side. You can also attach the legs on the back two corners first and then the front.

Place the ¼” nut on the bolt that is located on the base of the unit and attach the leg to the bolt. Swing the leg so that the foot of the leg is parallel with the 45-deg. angle of the front of the unit. Align the back leg to match the front leg.

Be careful not to bind the leg when bolting onto the unit so that it does not break. The legs are designed to face at a 45 degree angle so that they will face in the same direction as the slanted side of the face.

When the legs are bolted on and positioned where you like them, tighten the four (4) nuts. Make sure not to over tighten the nuts and twist them off.

CLEARANCES

NOTE: Clearances for the Insert models are shown on pages 21-24

CONVENTIONAL CLEARANCES

A...SIDEWALL	3 In. (75 mm)
B...BACK WALL	3 In. (75 mm)..... (VERTICAL VENTING INSTALLATION REQUIRES A MIN. 3" CLEARANCE FROM COMBUSTIBLES TO VENT PIPE).
C...CORNER WALL	3 In (75 mm)..... (VERTICAL VENTING INSTALLATION REQUIRES A MIN. 3" CLEARANCE FROM COMBUSTIBLES TO VENT PIPE).
D...VENT PIPE TO WALL	3 In (75 mm)..... (MAINTAIN 3" INCH CLEARANCE FOR ALL INSTALLATIONS)
E...FLOOR PROTECTION FRONT	6 In (150 mm)
F...FLOOR PROTECTION SIDES	6 In (150 mm)

Floor protection must be 3/8" inch minimum thickness non-combustible material or equivalent extending beneath heater and to the front/side/rear as indicated.

HORIZONTAL INSTALLATION

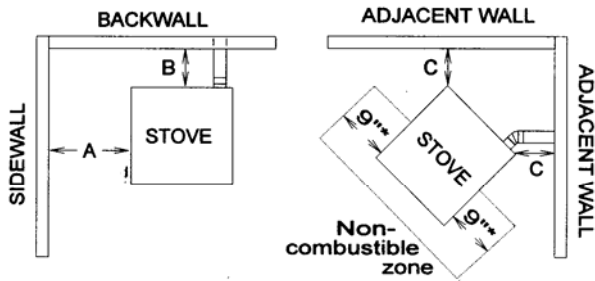

FLOOR PROTECTION

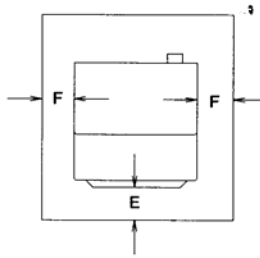

* Sides of the stove to the front of the grill openings must have a 9"inch clearance.

VERTICAL INSTALLATION

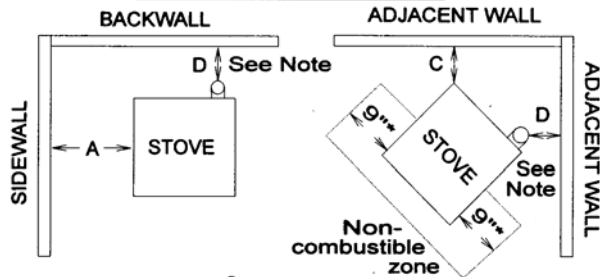

CHIMNEY AND CONNECTOR: 3" LISTED PELLET VENT ONLY

NOTE: REGARDLESS OF STOVE CLEARANCE, VENT PIPE MUST ALWAYS HAVE A 3" INCH CLEARANCE.

ALCOVE CLEARANCES

MIN. ALCOVE WIDTH	27 In. (694 mm)
MIN. ALCOVE HEIGHT	47 In. (1194 mm)
MAX. ALCOVE DEPTH	36 In. (914 mm)

WARNING: THE MINIMUM CLEARANCES LISTED ABOVE ARE BASED ON 3" INCH PL LISTED PELLET VENT PIPE. IF YOUR APPIANCE IS NOT PROPERLY INSTALLED A HOUSE FIRE MAY RESULT. PLEASE FOLLOW THE PIPE MANUFACTURERS INSTRUCTIONS AND LOCAL BUILDING CODES FOR THE CLEARANCE TO COMBUSTIBLES REQUIRED FOR THE INSTALLATION OF THE VENT PIPE BEING USED.

GUIDELINES FOR EXHAUST VENTING SYSTEMS DESIGN

It is recommended that only an authorized Magnum installer install your wood pellet stove. The following installation guidelines must be followed to ensure conformity with both the safety listing of this stove and to local building codes.

- ✓ A listed 3” or 4” type “PL” pellet vent exhaust system must be used for FREESTANDING installation and attached to the pipe connector provided on the back of the stove. Use a 3” to 4” adapter for 4” pipe. A cap must be used at the termination of type “L” vent chimneys.
- ✓ Do not terminate vent in any **enclosed or semi-enclosed** area, such as; carports, garage, attic, crawl space, under a sundeck or porch, narrow walkway or closed area, or any location that can build up a concentration of fumes such as a stairwell, covered breezeway, etc.
- ✓ Vent surfaces can get hot enough to cause burns if touched by children. Non-combustible shielding or guards may be required. **Do not install a flue damper in the exhaust vent of this unit.**
- ✓ Termination must exhaust above air inlet elevation. **It is recommended that at least 3 ft. of vertical pipe be installed when the appliance is vented directly through a wall or in a basement.** This will create some natural draft to prevent the possibility of smoke or odor during appliance shutdown and to keep exhaust from causing a nuisance or hazard from exposing people or shrubs to high temperatures. In any case, the safest and preferred venting method is to extend the vent through the roof. **Do not connect this unit to a chimney flue serving another appliance.**
- ✓ Distance from doors and windows, gravity or ventilation air inlet into building:
Not less than 4 ft. / 1.2 m below, 4 ft. / 1.2 m horizontally from, 1 ft. / 305 mm above (This does not apply if the windows are non-opening or have been fixed so they cannot open.)
- ✓ Distance from bottom of termination and grade – 1 ft. / 305 mm minimum. This is conditional upon the plants and nature of grade surface. The exhaust gases are not hot enough to ignite grass, plants or shrubs located in the vicinity of the termination. The grade surface must not be a lawn. Distance from bottom of termination and public walkway is 7ft. / 2.1m minimum.
- ✓ Distance to combustible materials – 2 ft. / 610 mm. This includes adjacent building, fences, protruding parts of the structure, roof overhang, plants and shrubs, etc.
- ✓ It is recommended that a single or double clean-out “tee”, for cleaning the vent in both directions, be installed at every 90-degree junction to enable collection of fly ash and to permit periodic cleaning of the exhaust system. 90-degree elbows accumulate fly ash and soot, thereby reducing exhaust flow and performance of the stove.
- ✓ Total length of horizontal vent must not exceed 10 feet / 3,000 mm. All joints in the vent system must be fastened by at least three (3) screws, and all joints must be sealed with *high temp* RTV silicone sealer to be airtight.
- ✓ A 3” inch single-wall, stainless steel flexible or rigid exhaust pipe should be used for INSERT installations and must be attached to the stove with a single-wall, stainless steel “tee” with a clean-out cap. The stainless steel “tee” should be inclined at 45-degrees to enable the vent to be centered on the stove and allow the “tee” to be cleaned without removing the stove (see diagram 11.1).
- ✓ When venting into an existing masonry or factory built chimney, the chimney must be cleaned, with all creosote removed. The chimney must be a type suited for solid fuel. **WARNING:** The chimney and the chimney connections must be kept clean and in good condition.
- ✓ The “PL” venting or single wall stainless exhaust system must be installed so as to be GAS TIGHT! The vent manufacturer’s installation procedures must be followed. In addition, pipe connections, joints and all pipe seams within the home should be sealed with high temperature RTV silicone sealer.
- ✓ If an insert is to be installed into an unlined masonry chimney, it is recommended that a 3” or 4” inch stainless steel pipe be extended to the top of the existing chimney. The top of the existing chimney should be sealed with a steel plate (see diagram 11.2).

GUIDELINES FOR EXHAUST VENTING SYSTEMS DESIGN, CONT.....

To determine whether a 3” or 4” inch exhaust system should be used, follow the guidelines below:

- 1) Determine the “equivalent pipe length” for each component used according to the comparison chart below. Add the “equivalent pipe length” of all components to get the “total equivalent pipe length”.
- 2) Determine the altitude at which you are installing the stove.
- 3) Cross-reference the “total equivalent pipe length” and the altitude using the graph below.

NOTE: The “total equivalent pipe length” should not exceed 30’ feet.

Diagram 11.1

Component	Equivalent Length	Equivalent Pipe Length			
			=		
Horizontal Straight Pipe	Actual Length in ft. x 1.0	Horizontal Pipe	=	1 x (2+1) =	3 ft.
Vertical Straight Pipe	Actual Length in ft. x 0.5	Vertical Pipe	=	0.5 x 8 =	4 ft.
90° Elbow or Tee	5.0 feet	90 Degree Tee	=	2 x 5 =	10 ft.
45° Elbow	3.0 feet	45 Degree Tee	=	1 x 3 =	3 ft.
		TOTAL	=		20 ft.

NOTE: These are guidelines only. Proper venting is accomplished by design and common sense. In most installations 3” inch diameter venting is adequate. If it does not vent properly you will have to change it to 4” inch.

Diagram 11.2

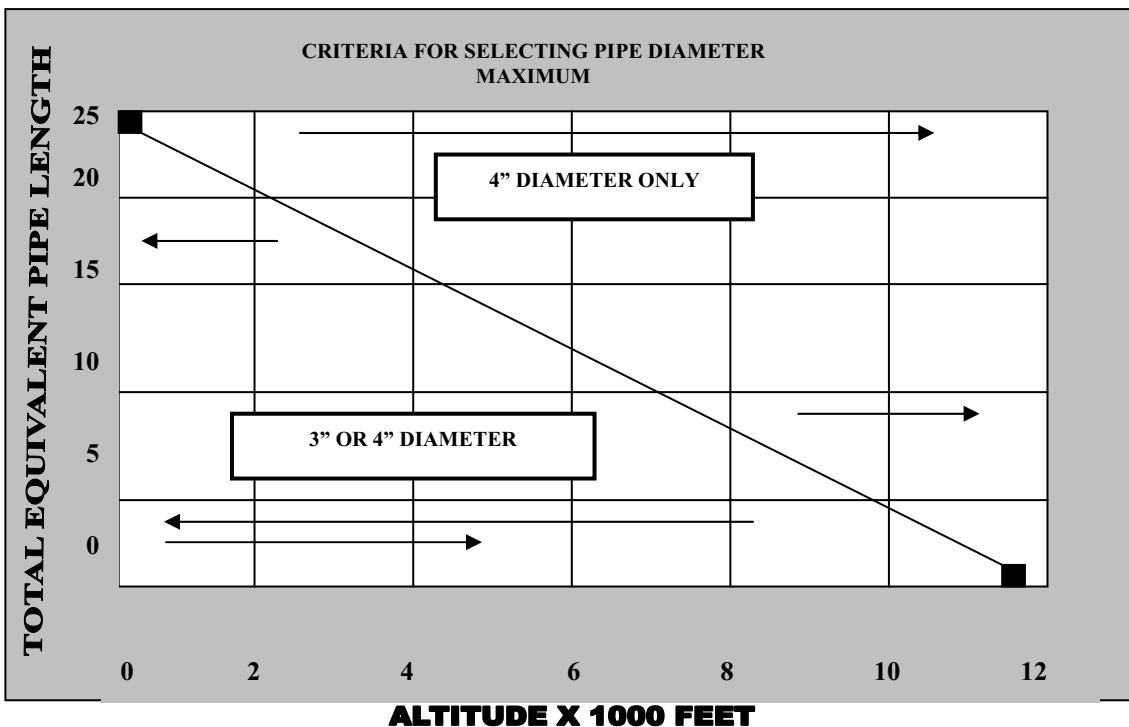

DESIGN GUIDELINES FOR OUTSIDE COMBUSTION AIR CONNECTION

OUTSIDE MAKE-UP AIR FOR COMBUSTION IS REQUIRED ON ALL INSTALLATIONS

- 1) For FREESTANDING installations with horizontal through-the-wall exhaust, it is REQUIRED that the stove combustion air intake be connected to a fresh air intake outside. If the home is newer or has been tightly insulated it is imperative to the operation of the unit to install outside combustion air. If you do not, then an additional 6" inch intake into the furnace room in the basement is required.
- 2) For INSERT installations into an existing fireplace, or FREESTANDING installations with a vertical exhaust, outside air connection is required. It is not recommended to exit the fresh air intake out the top of the chimney.
- 3) Connection to outside the house is REQUIRED for all installations.

IMPORTANT: It is the customer's responsibility to make sure that there is adequate fresh air to the home so that the MagnuM appliance does not become the fresh air source.

90 DEGREE BEND TERMINATION

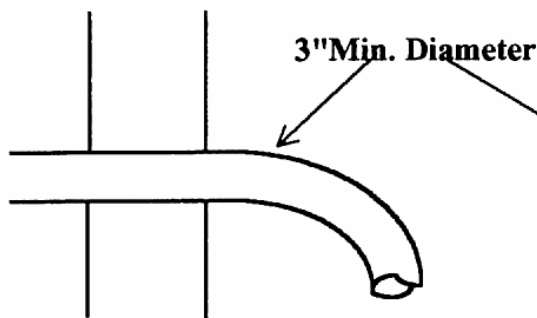

WIND HOOD TERMINATION

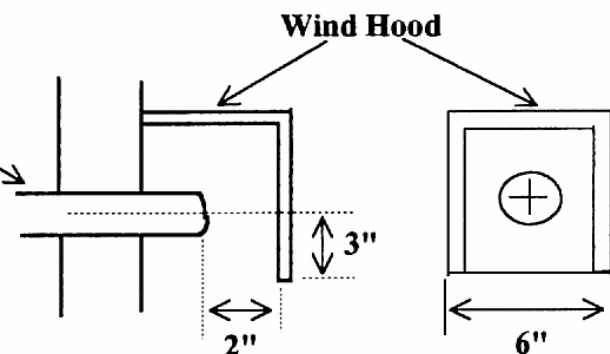

- 4) Only non-combustible piping 3" inches in diameter is approved to use for outside air connections (straight or flexible). PVC pipe is NOT approved and should NEVER be used.
- 5) If the air inlet is connected to the outside, it MUST be terminated with a vertical 90-degree bend (down) or with a wind hood. Failure to do so could result in a burn back during high winds blowing directly up the air inlet during a simultaneous power failure (see diagram above).
- 6) It is important not to terminate the inlet of the fresh air intake too close to the venting outlet for the exhaust. It is recommended that the inlet for the fresh air is a minimum of 3' to 5' feet away from the venting outlet and at least 1'-2' feet below.
- 7) Blockage, excessive length, or bends in the air intake pipe will starve the stove of combustion air. A 90-degree bend is equivalent in restriction to approximately 30" inches of straight inlet pipe.

INSTALLATION PRECAUTIONS

CAUTION: Do not install this appliance in any manner other than as described in this manual. If you have any questions about properly venting or installing your **MagnuM** corn/biomass/wood pellet stove, please contact your dealer or American Energy Systems, Inc. for information.

NOTE: THIS STOVE MUST BE BURN TESTED OUTSIDE IN A WELL VENTILATED AREA FOR AT LEAST FOUR (4) HOURS. THIS WILL CURE THE PAINT AND SEASON THE STOVE METAL. SMOKING AND STEAMING IS NORMAL DURING THE CURING PROCESS, AND MAY CONTINUE DURING THE FIRST FEW TIMES THE STOVE IS USED.

The **ONLY** authorized exhaust vent pipe for this appliance is **3” or 4” inch listed Type PL pellet vent pipe**, designed for use with pellet stoves. This stove may be connected to an existing factory-built chimney using pellet vent pipe as a connector, and a 3”-4”, 3”-6”, or 3”-8” **PELLET VENT to CHIMNEY ADAPTER**. Follow the pellet vent pipe manufacture’s instructions for the installation of the vent pipe being used. (See “Existing Vertical Installation”).

As you plan your installation, consider the following:

- The stove should be placed as central in the home as possible. Consider safety, convenience, traffic flow and the fact that the stove will need a venting system and fresh air to the outside of the home.
- Before drilling or cutting holes, select the location of the appliance. Determine where the ceiling rafters, wall studs or floor joists are located before making any large holes as the appliance may have to be moved.
- Care must be taken to maintain minimum clearances to combustibles as per local building codes, fire codes, and the safety listing tag on the inside hopper lid.
- An outside air source **must be** connected to the stove and can be brought in through the sidewall or vented crawl space. Flexible or rigid pipe should be used and will connect to the adaptor on the back of the stove. (See air inlet location under the **CLEARANCE** section of this manual)
- Place the stove where you will enjoy watching the fire along with getting the best heat distribution possible. Locating the stove in a closed room will not allow the unit to perform properly. Installing the stove in an un-insulated area will also not allow the stove to heat the home properly.
- If the home was not designed with proper heat circulation, the stove will not perform properly. Make sure that the installer looks at the entire home as a unit when installing your **MagnuM** appliance. Make sure that there is adequate cold air returns to pull the heat to adjoining rooms.

DO NOT CONNECT THIS STOVE TO A CHIMNEY FLUE SERVING ANOTHER APPLIANCE.

DO NOT USE SINGLE WALL PIPE FOR ANY INSTALLATION.

DO NOT INSTALL A FLUE DAMPER IN THE EXHAUST VENTING SYSTEM OF THIS UNIT. THIS EXHAUST SYSTEM IS PRESSURIZED.

Electrical power is 115volt-60 Hz. The stove is provided with a six foot grounded electrical cord, and should be connected to a standard 3 prong 115volt, 60 Hz electrical outlet. (Make sure you have a surge protector installed.) Do not route the cord in front of, or under the stove.

NOTE: A MAJOR CAUSE OF VENT RELATED FIRES IS FAILURE TO MAINTAIN REQUIRED CLEARANCES (AIR SPACES) TO COMBUSTIBLE MATERIAL. PLEASE FOLLOW THE VENT PIPE MANUFACTURERS INSTRUCTIONS AND LOCAL BUILDING CODES FOR THE PROPER CLEARANCES TO COMBUSTIBLES REQUIRED FOR THE INSTALLATION OF THE VENT PIPE BEING USED.

INSTALLATION CONFIGURATIONS

The Magnum Corn/Biomass/Wood Pellet Appliances may be installed as follows:

- 1) A freestanding unit (with a pedestal only).
- 2) A hearth mounted fireplace insert into a masonry or factory built fireplace.
- 3) A built-in heater mounted in an alcove with a pedestal.
- 4) A built-in heater mounted on a non-combustible floor without a pedestal.

MOBILE HOME INSTALLATION REQUIREMENTS

IN ADDITION TO THE STANDARD INSTALLATION INSTRUCTION, THE FOLLOWING REQUIREMENTS ARE MANDATORY FOR INSTALLATION IN A MOBILE HOME:

WARNING
DO NOT INSTALL IN SLEEPING ROOM

- 1) Stove must be permanently bolted to the floor.
- 2) Stove must have permanent outside air source.
- 3) Stove must be permanently, electrically ground to the steel chassis of the mobile home. (12 ga. or larger wire)
- 4) All vertical chimney vent must have wall supports every five (5') feet.
- 5) All exhaust systems must have a spark arrestor.

CAUTION
**The structural integrity of the mobile home floor, wall and ceiling must be maintained.
Check with your local building official as other codes may apply.**

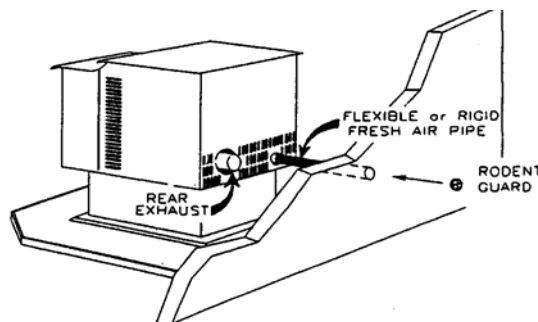
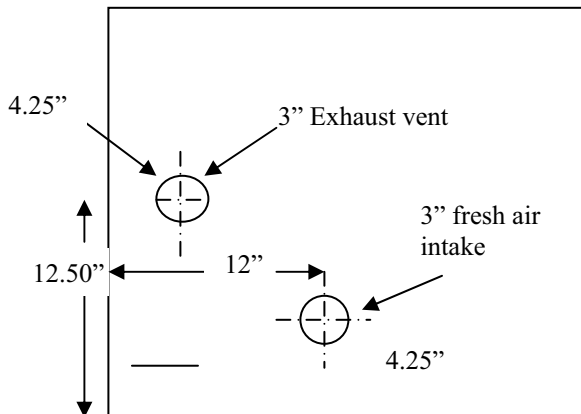

Outside air can be drawn through the floor or through the sidewall.

VENT TERMINATION GENERAL INSTRUCTIONS

NOTE: The following are general instructions for installing this appliance.

THE PELLET VENT MANUFACTURER'S INSTRUCTIONS SHOULD BE FOLLOWED FOR THE VENT PIPE BEING USED. USE ONLY 3" or 4" INCH LISTED TYPE PL PELLET VENT PIPE.

WARNING: Shut off all electrical power to the wall or room where the appliance is going to be installed before cutting any holes. Be careful not to drill or cut into any water lines or electrical wiring as water damage or electrical fire may result.

Upon determining the best location for your new appliance, maintain at least the minimum allowable clearances. Line up a plumb bob to the flue collar on the stove with the location for the hole in the wall or ceiling before drilling or cutting any holes. (See rear exhaust and air inlet locations under the **CLEARANCE** section of this manual.) **Be sure to allow for any stove pad that you will be placing underneath the unit.**

Prepare the vent pipe for painting (if you are painting the venting) by wiping down with straight vinegar. Rinse vinegar off with clean water and allow the pipe to dry. Use high temperature paint as directed by the manufacturer (the standard paint is Stove Bright Metallic Black). Let the paint dry for a couple hours before assembling.

Drill and enlarge the hole as required for installation of the wall thimble, vent pipe and components **per the pellet vent manufacturer's instructions.**

Connect the pipe and lock the joints as directed by the pellet vent manufacturer, and secure the vent pipe to the flue collar on the back of the stove. Add a small bead of RTV high temperature silicone around the outside edge of the flue collar prior to securing the vent pipe. Drill and attach the vent pipe to the flue collar with sheet metal screws. **Alternate (preferred) method:** Attach the approved PL pipe adaptor on the back of the exhaust pipe located on the rear of the appliance, secure with a 3" hose clamp and then attach all venting to the pipe adaptor.

Do not terminate the vent in any enclosed or semi-enclosed area, such as a carport, garage, attic, crawl space, under a sun deck or porch, in a narrow walkway or closely fenced area, stairway, covered breezeway, or any other location which can build up a concentration of flue gases.

Vent surfaces can become hot enough to cause burns if touched. Non-combustible shielding or guards may be required.

Note: Make sure that you leave adequate clearance between the back of the unit and the wall to allow for proper cleaning, servicing, and for when you open the hopper lid, that it does not hit the wall. It is recommended that you leave 4"-6" inches of clearance between the appliance and the back wall of the home.

NOTE: THE VENT PIPE SHOULD BE INSPECTED FREQUENTLY TO VERIFY THE INTEGRITY OF THE VENTING SYSTEM AND TO INSURE THAT NO OBSTRUCTIONS OR BUILD-UP EXIST WITHIN THE VENT PIPE. FAILURE TO INSPECT THE VENT PIPE CAN CAUSE A MALFUNCTION OR HAZARDOUS OPERATION OF THE STOVE.

HORIZONTAL INSTALLATION

EXHAUST VENT TERMINATION SHALL BE AS FOLLOWS:

A MINIMUM OF 4' FEET/1220mm BELOW, BESIDE AND 1' FOOT ABOVE ANY DOOR OR WINDOW THAT OPENS, OR ANY OPENING INTO A BUILDING.

A MINIMUM OF 2' FEET/610mm FROM ANY ADJACENT BUILDING OR OVERHANG.

A MINIMUM OF 7' FEET/2130mm ABOVE GRADE, WHEN LOCATED ADJACENT TO PUBLIC WALKWAYS.

A MINIMUM OF 2' FEET/610mm ABOVE GRASS, PLANTS OR OTHER COMBUSTIBLES.

Note: The pipe lengths shown are for reference only.
Your actual pipe length requirements may differ.

SINGLE WALL PIPE SHALL NOT BE
USED FOR ANY INSTALLATION.

HORIZONTAL INSTALLATION SHALL
BE A MAXIMUM OF 5' FEET.

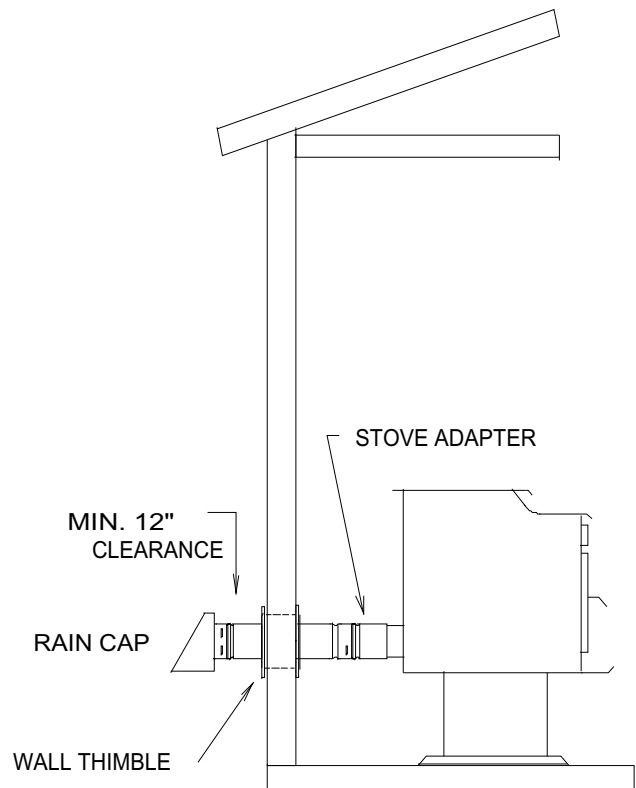
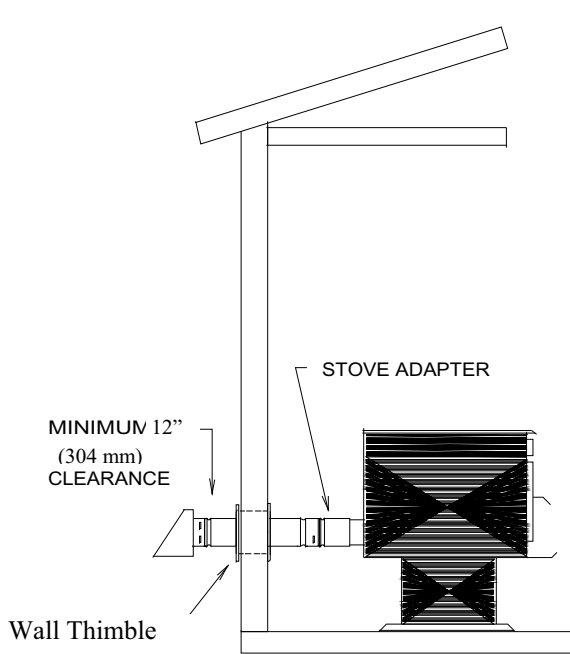

WARNING:
Vent surfaces can become hot enough to cause burns
if touched. Non-combustible shielding may be required.

**PLEASE FOLLOW THE PELLET VENT MANUFACTURER'S INSTRUCTIONS AND LOCAL BUILDING CODES
FOR THE CLEARANCES TO COMBUSIBLES REQUIRED FOR INSTALLATION OF THE VENT PIPE BEING
USED.**

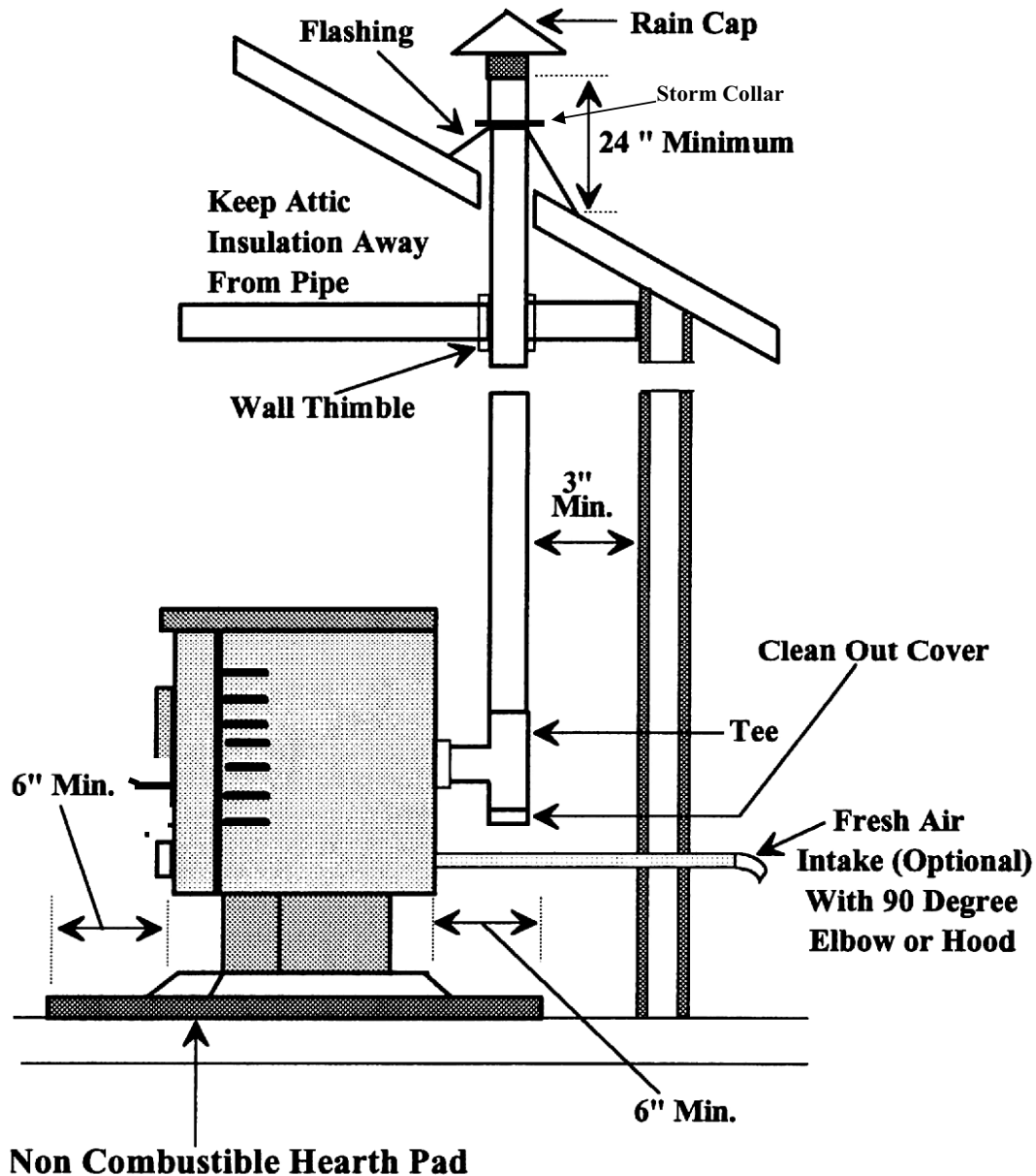

INSIDE VERTICAL PIPE WITH ROOF TERMINATION

VERTICAL INSTALLATION

GUIDELINES FOR CONNECTING TO AN EXISTING FACTORY-BUILT CHIMNEY:

1. Inspect the chimney for the presence of creosote, soot or other combustible deposits, and blockage or obstructions. Thoroughly clean the chimney and remove any obstructions.
2. Thoroughly inspect the chimney for soundness, proper clearances and presence of all necessary parts, including a chimney cap, prior to making the connection.
3. This stove may be connected to an existing ceiling-mounted factory-built chimney with a diameter of 4", 6", or 8" inches.
4. Use a 3"-4", 3"-6" or 3"-8" inch pellet vent to chimney adapter provided by the pellet vent manufacturer.
5. Use only listed 3" inch Type PL pellet vent pipe between the stove and the chimney.
6. Follow the pellet vent manufacturer's instructions to assemble the vent pipe and make the connection to the chimney.

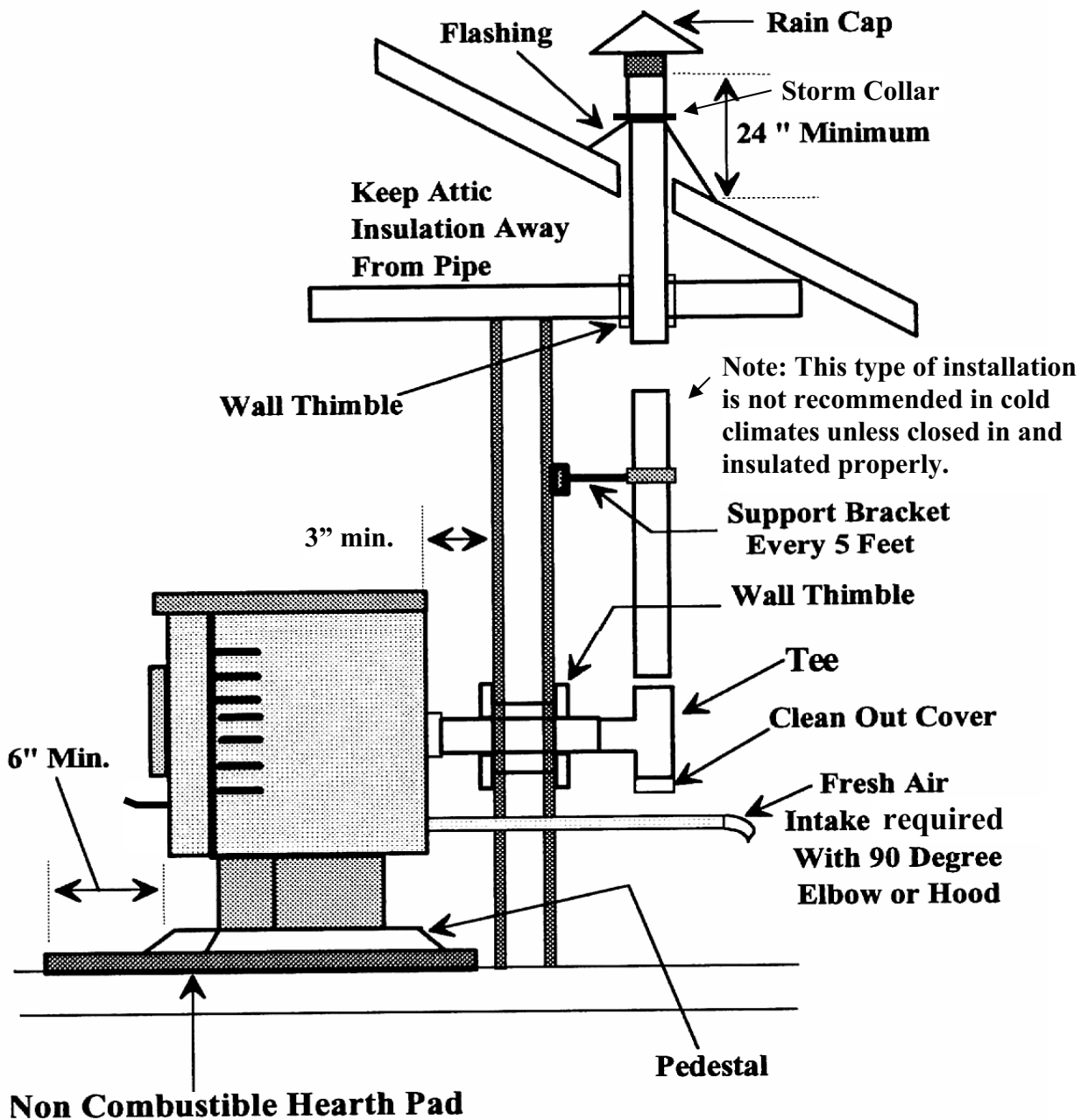

**THROUGH THE WALL, VERTICAL PIPE INSTALLATION
WITH TERMINATION THROUGH THE ROOF**

Warning: Unless the venting is enclosed and insulated, this installation will cause poor venting, excess ash buildup, premature failure of exhaust system, staining of the house siding and serious creosote buildup. This installation should not be used in a cold climate area.

AC CONTROL PANEL/THERMOSTAT HOOK-UP

WARNING: ALWAYS DISCONNECT POWER CORD DURING ANY ELECTRICAL OPERATION

1. Remove control panel from protective packaging.
2. Connect the one way molex plug to the control panel; do not pull on the wire harness inside the stove.

NOTE: Use only a low voltage mercury or bi-metal thermostat switch. (No power required on thermostat)

NOTE: If you are not going to use the thermostat function then skip steps #4 - #8 and go to Step #9.

3. Locate the thermostat on a wall six (6') to (10') feet away.
4. Route the wires into the stove near where the AC power cord enters.
5. Pull the thermostat wire through to the control panel cut-out.
6. Move the factory installed jumper from the upper position to the lower position. (see details below)
7. Connect the thermostat wires to the two terminals on the back of the control panel.
When the room temperature drops below the thermostat setting, the thermostat switch will close, allowing the stove to operate at the medium or higher settings. When the room temperature matches the thermostat setting, the thermostat switch will open, allowing the stove to operate at the low setting.
8. Locate the control panel into the side panel cut-out and secure with four (4) #7 X 1/2 Phillips screws (supplied). Do not over tighten. Set control board to thermostat operation.
9. The stove is now ready for operation. Refer to the **OPERATING INSTRUCTIONS**.

Note: The thermostat function of the stove will cycle with the room temperature when the "Fuel Feed Control" is set at a medium or higher setting.

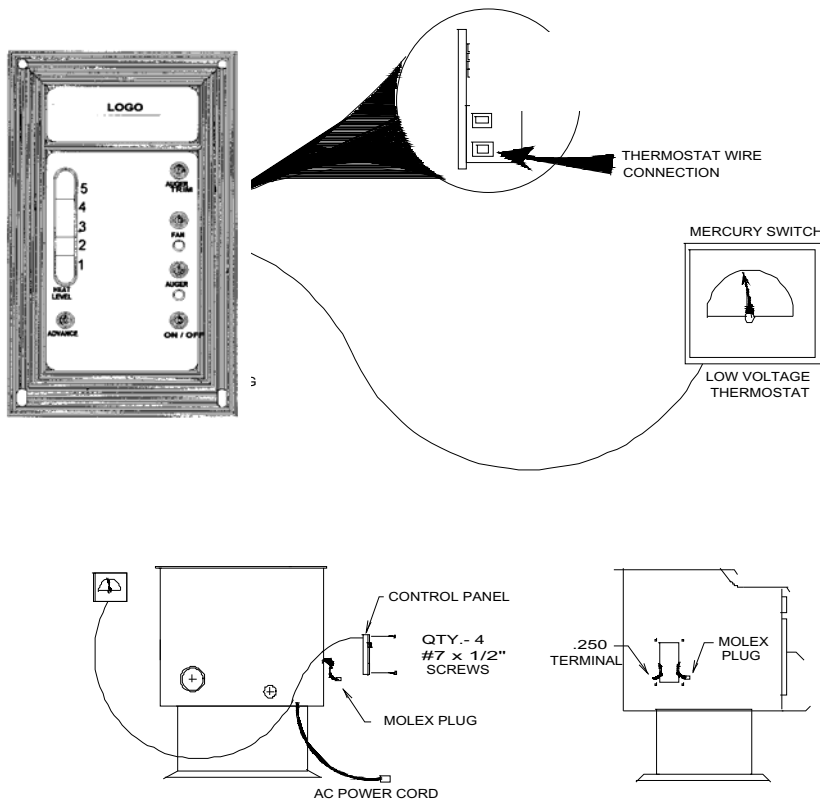

DC CONTROL PANEL/THERMOSTAT HOOK-UP

WARNING: ALWAYS DISCONNECT POWER CORD DURING ANY ELECTRICAL OPERATION

10. Remove control panel from protective packaging.
11. Connect the one way mox plug to the control panel; do not pull on the wire harness inside the stove.

NOTE: Use only a low voltage mercury or bi-metal thermostat switch. (No power required on thermostat)

NOTE: If you are not going to use the thermostat function then skip steps #4 - #8 and go to Step #9.

12. Locate the thermostat on a wall six (6') to (10') feet away.
13. Route the wires into the stove near where the AC power cord enters.
14. Pull the thermostat wire through to the control panel cut-out.
15. Move the factory installed jumper from the upper position to the lower position. (see details below)
16. Connect the thermostat wires to the two terminals on the back of the control panel. When the room temperature drops below the thermostat setting, the thermostat switch will close, allowing the stove to operate at the medium or higher settings. When the room temperature matches the thermostat setting, the thermostat switch will open, allowing the stove to operate at the low setting.
17. Locate the control panel into the side panel cut-out and secure with four (4) #7 X ½ Phillips screws (supplied). Do not over tighten. Set to Thermostat operation on the top front of the board.
18. The stove is now ready for operation. Refer to the **OPERATING INSTRUCTIONS**.

Note: The thermostat function of the stove will cycle with the room temperature when the "Fuel Feed Control" is set at a medium or higher setting.

The Thermostat wire connection is located on the back of the board just above the white mox connector.

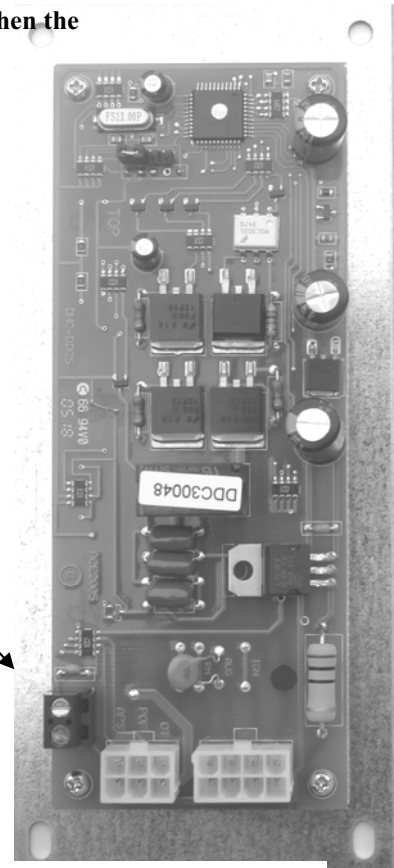
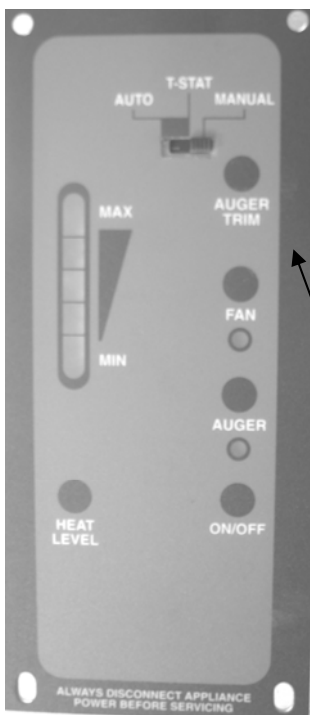

To operate the unit in the thermostatic operation mode, place the selector switch in the T-Stat position. (Center position)

MAGNUM WIN INSERT INSTALLATION

CLEARANCES - MASONRY FIREPLACES

FLOOR PROTECTION - The hearth and floor area underneath the insert, **MUST BE COMPLETELY NON-COMBUSTIBLE, WITH NO WOOD UNDERNEATH.**

The following are clearances to combustibles - **MASONRY FIREPLACE BUILT TO UBC CHAPTER 37.**

MINIMUM CLEARANCES TO COMBUSTIBLES

- A - Top of stove to mantle..... 15" in.
- B - Side of stove to sidewall..... 12" in.
- C - Side Hearth Extension..... 9" in.
- D - Hearth extension..... 16" in.

MINIMUM OPENING FOR INSERT INSTALLATION

- E - Height.....21.5" in.
- F - Depth.....16" in.
- G - Width (at front).....30" in.
- Width (at 15 inches depth).....21" in.

EXHAUST & FRESH AIR LOCATION

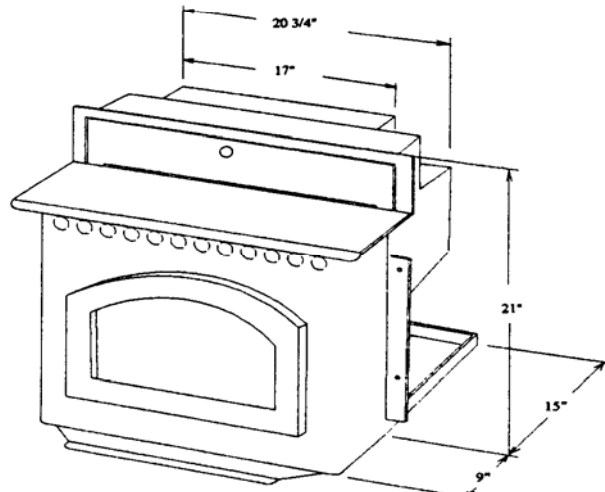
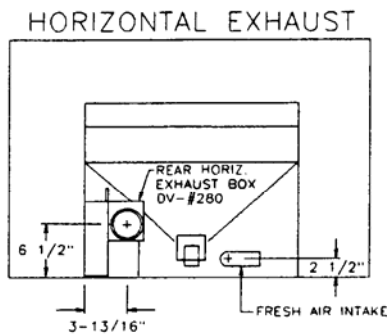
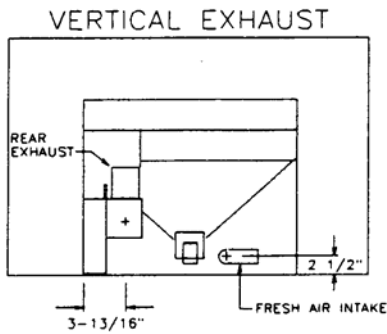
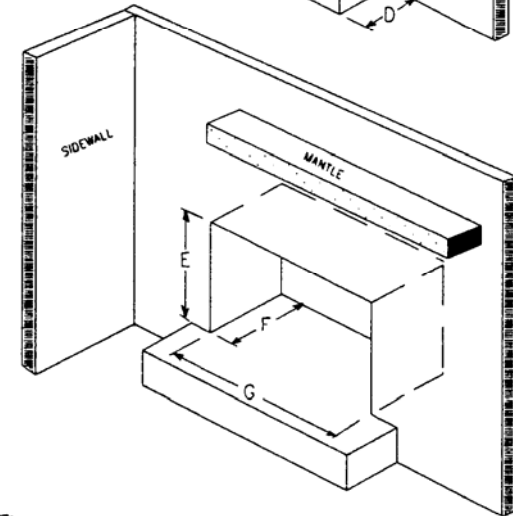
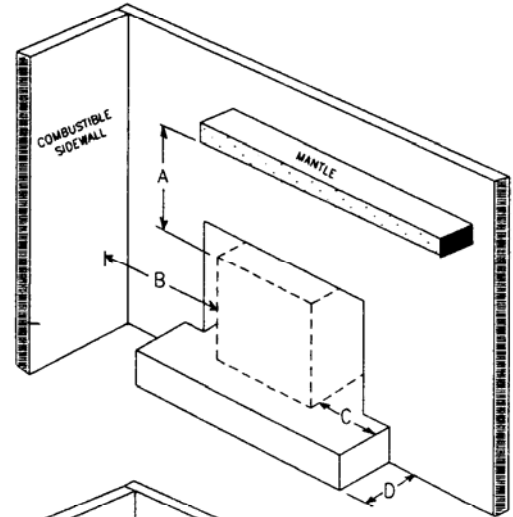

WIN INSERT INSTALLATION cont.

CLEARANCES - FRAMING TO COMBUSTIBLES

NOTE: DIAGRAMS ARE FOR REFERENCE ONLY. CONSULT WITH A BUILDING CONTRACTOR AND LOCAL BUILDING CODES FOR CONSTRUCTION REQUIREMENTS. FOLLOW THE PIPE MANUFACTURERS INSTALLATION INSTRUCTIONS AND CLEARANCES.

INSTALLATION PRECAUTIONS

1. Outside the house, make sure there are no obstructions for the installation of the chase and flue.
2. On the inside of the house, check the wall for the location of existing plumbing and electrical wiring.
3. Locate the wall studs on the inside wall and mark out the finished wall opening. Transfer the wall opening to the exterior wall by drilling pilot holes in the corners of the marked out wall opening. Cut the opening in the walls.
4. The depth of the flue chase will depend on the wall LISTED BELOW.
5. Frame the wall opening and chase according to local building codes.
6. Hearth and hearth extensions must be non-combustible construction as per UBC Chapter 37 for fireplaces and extend 6" inches in front of appliance.
7. Install appliance into the opening, check the clearances to combustibles.
8. Install the flue pipe per manufacturers instructions and clearances. Secure the pipe using wall brackets every 4 feet of pipe.
9. Fire stops must be installed in the chase for each floor level. Install siding on chase.
10. Electrical power is 120-60hz. Do not route the cord in front of, under or along the side of the stove. Do not Remove the grounding prong from the power cord.
11. See OPERATING INSTRUCTIONS for starting your stove.

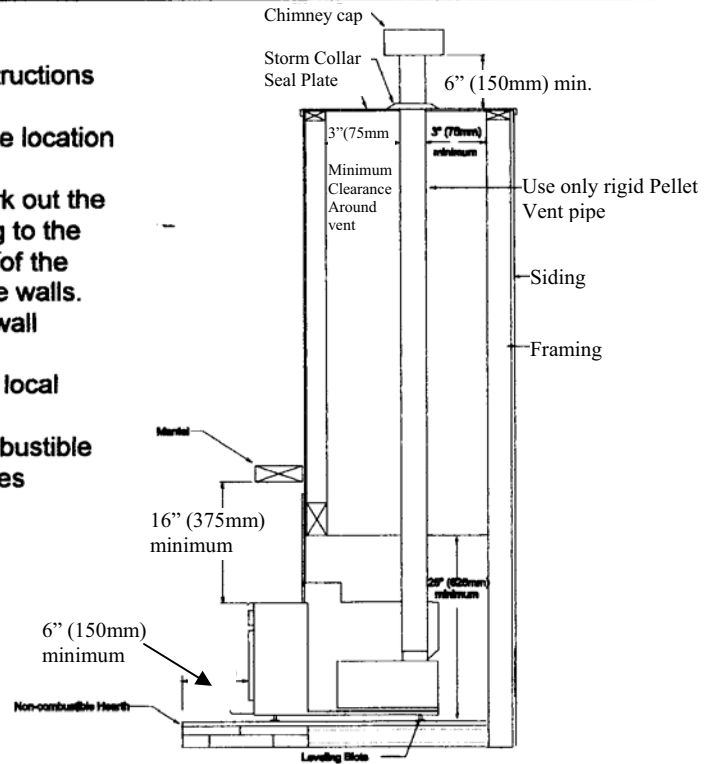

Minimum Clearances to Combustibles

- | | | |
|----|-----------------------------|------------|
| A. | Insert to Sidewall..... | 12 inches |
| B. | Front Hearth Extension..... | 6 inches |
| C. | Side Hearth Extension..... | 9 inches |
| D. | Side of Stove to Enclosure. | 5.5 inches |
| E. | Opening Height..... | 25 inches |
| F. | Opening Depth..... | 24 inches |
| G. | Opening Width..... | 32 inches |

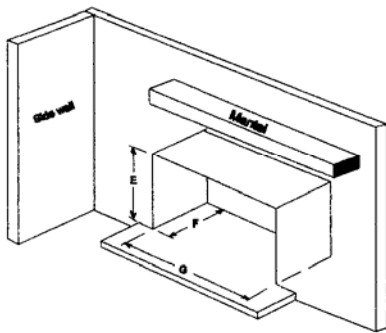

(8)

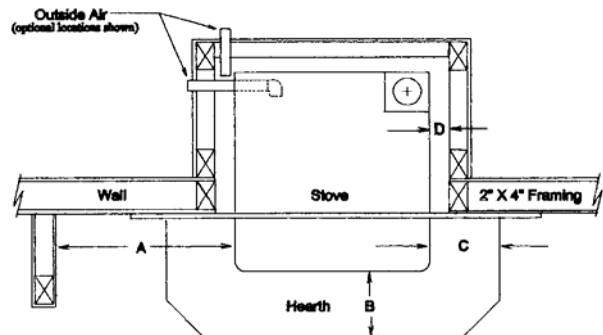

WIN INSERT INSTALLATION cont.

CLEARANCES - UL Listed Factory Built Fireplace

FLOOR PROTECTION - The hearth and floor area underneath the insert must be continuous non-combustible material such as cement, brick, ceramic tile, or other approved material for floor protection.

The following are clearances to combustibles:

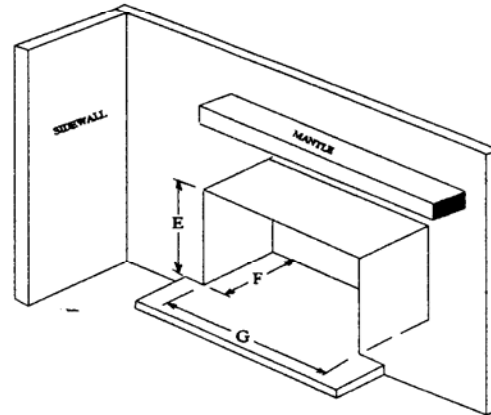
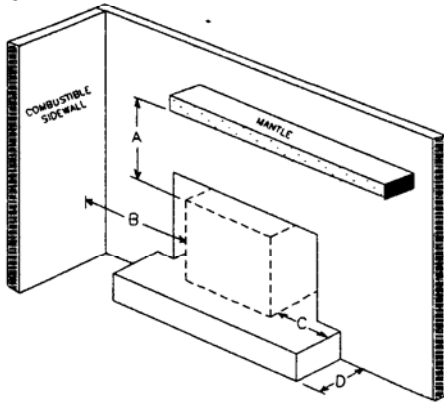

UL Listed Factory Built Fireplace

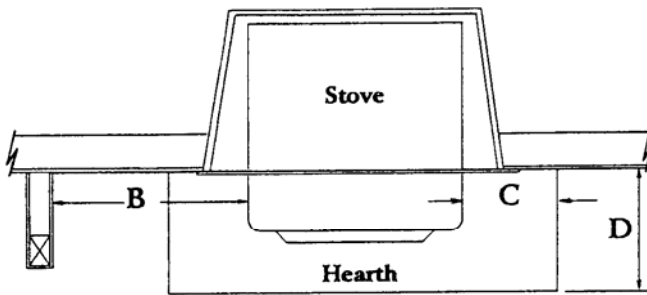

MINIMUM CLEARANCES TO COMBUSTIBLES

- A - Top of stove to mantel..... 15”In.
- B - Side of stove to sidewall.... 12”In.
- C - Side of hearth extension.... 9”In.
- D - Hearth extension..... 16”In.

MINIMUM OPENINGS FOR INSERT INSTALLATION

- E - Height..... 21.5” In.
- F - Depth..... 16” In.
- G - Width at front..... 30” In.
- Width at 16” depth...21” In.

NOTE:

For a raised Hearth, you can have a decorative skirting made by your installer to finish off the front of the unit. The skirting must be made out of non-combustible materials and must support the weight of the unit.

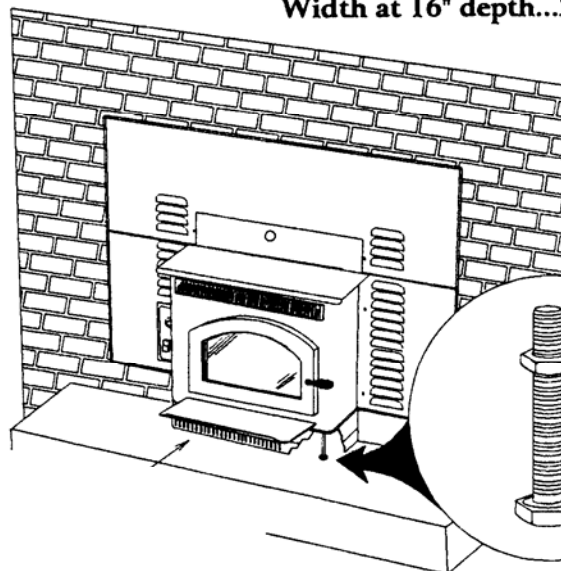

When extending the unit beyond a raised hearth, you must use some type of support bolt to hold and level the unit.
(not provided)

INSTALLATION INSTRUCTIONS

VERTICAL INSTALLATION

The fireplace and chimney should be cleaned before installing. Painting the interior will help seal any odors.

1. Measure the fireplace to determine that the stove will fit to specifications and clearances to combustibles per safety label and clearance section of this manual.
2. Remove or secure the flue damper to the open position.
3. Venting of the exhaust may be terminated 36" above the bottom seal plate or extended to the chimney top.
4. **Extending the exhaust to the chimney top is recommended in all fireplaces.**

EXTENDING EXHAUST TO CHIMNEY TOP

1. Route 3" flex stainless steel chimney pipe at least 3' beyond the desired termination point to insure enough length for proper connection to the stove flue collar when the stove is positioned in the fireplace opening. (6" min. length of liner is required at top after liner is properly installed).
2. An outside air source must be connected to the stove with 2" diameter Class 0 or Class 1 flexible duct pipe or other metal pipe at least 0.016 inches thick. Fresh air can be brought in through the ash clean-out door, top of chimney, or a hole drilled through the rear of chimney.
3. Measure and install bottom seal plate and top seal plate. Cut out holes for exhaust and combustion air.
4. Seal plates with non-hardening mastic. Place non-hardening mastic around exhaust and fresh air pipe.
5. Install chimney cap on exhaust. Terminate fresh air at top by bending pipe as illustrated. Place 1/4" mesh screen on end of fresh air for rodent guard.
6. Provide or otherwise install 110 volt A.C. power receptacle as required to make the necessary power connections. (In some cases a power source can be brought in through the rear ash door or ash trap in floor)
7. Position the stove in the fireplace and adjust the leveling bolts if necessary.
8. Route power cord out the side of the stove closest to 110V receptacle. **Do not place power cord next to the side of stove. Do not route power cord under the stove.**
9. Place the power cord behind the side panel and use the "channel" created by the mortar joint between brick or rock to route the power cord out of the firebox.
10. Connect the 3" flex stainless steel pipe to the stove flue collar and slide stove back to final position.

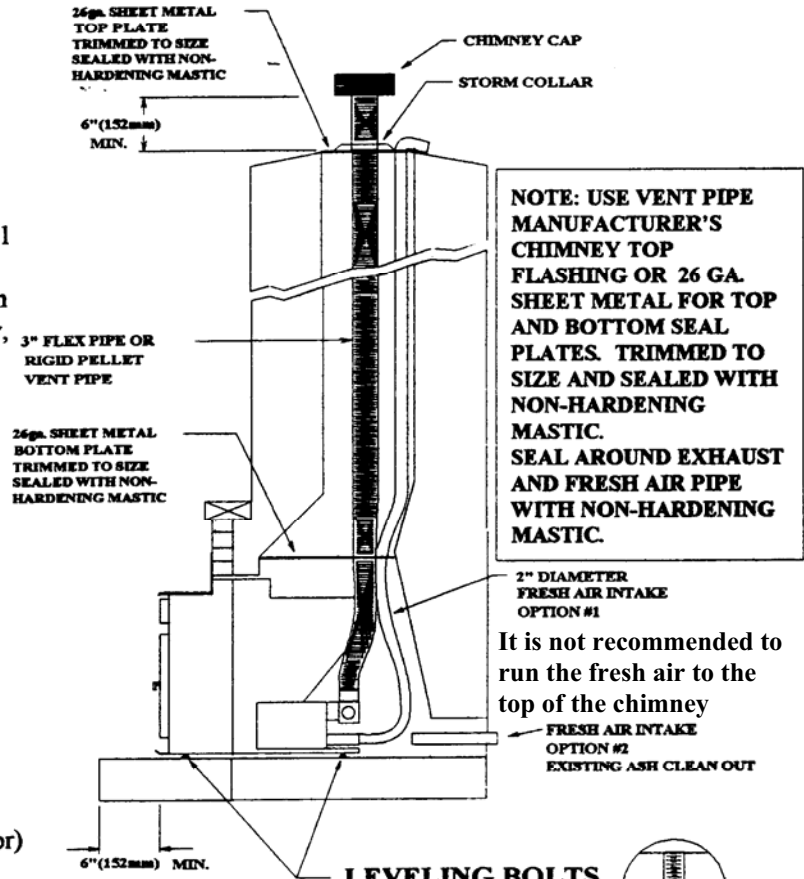

NOTE: USE VENT PIPE MANUFACTURER'S CHIMNEY TOP FLASHING OR 26 GA. SHEET METAL FOR TOP AND BOTTOM SEAL PLATES. TRIMMED TO SIZE AND SEALED WITH NON-HARDENING MASTIC. SEAL AROUND EXHAUST AND FRESH AIR PIPE WITH NON-HARDENING MASTIC.

It is not recommended to run the fresh air to the top of the chimney

FRESH AIR INTAKE OPTION #2 EXISTING ASH CLEAN OUT

Your installer will determine what type of leveling bolts or other means that will level the unit properly.

It is best to route the fresh air intake either out the back of the fireplace cavity or down and out to an outside air source. Running the fresh air up and out the top of the chimney can cause excessive draft issues.

INSTALLATION INSTRUCTIONS....Continued

HORIZONTAL VENT TERMINATION CLEARANCES

EXHAUST VENT TERMINATION SHALL BE AS FOLLOWS:

A MINIMUM OF 4 FEET/1220mm BELOW, BESIDE AND 1 FOOT ABOVE ANY DOOR OR WINDOW THAT OPENS, OR ANY OPENING INTO A BUILDING.

A MINIMUM OF 2 FEET/610mm FROM ANY ADJACENT BUILDING OR OVERHANG.

A MINIMUM OF 7 FEET/2130mm ABOVE GRADE, WHEN LOCATED ADJACENT TO PUBLIC WALKWAYS.

A MINIMUM OF 2 FEET/610mm ABOVE GRASS, PLANTS OR OTHER COMBUSTIBLES.

PLEASE FOLLOW THE PIPE MANUFACTURER'S INSTRUCTIONS AND LOCAL BUILDING CODES FOR THE CLEARANCE TO COMBUSTIBLES REQUIRED FOR INSTALLATION OF THE VENT PIPE BEING USED.

HORIZONTAL INSTALLATION INTO A MASONRY FIREPLACE

Non-combustible fireplace hearth and hearth extension.

Note: For horizontal venting use Horizontal Vent Adaptor

1. Measure the fireplace to determine that the stove will fit to specifications and clearances to combustibles per safety label and clearance section of this manual. Maintain exhaust termination clearances as shown above.
2. Maintaining the minimum allowable clearances, determine the exhaust and combustion air hole location
Note: Combustion air may be installed vertically through the chimney cavity.
3. Be careful not to drill or cut into any water lines or electrical wiring as water damage or electrical fire may result.
4. Enlarge the hole as required for the installation of the listed pellet vent pipe.
5. Position the stove in the fireplace and adjust the leveling bolts if necessary.
6. Install the 3" rigid pellet vent pipe through the opening and connect to stove flue collar.
7. Place listed cap on exterior maintaining minimum clearance as shown.
8. Provide or otherwise install 110 volt A.C. power receptacle as required to make the necessary power connections. (In some cases a power source can be brought in through the rear ash door or ash trap in the floor) **Do not route the power cord under the stove. Do not route the power cord next to the side of the stove.**
9. Place the power cord behind the side panel and use the "channel" created by the mortar joint between brick or rock to route the power cord out of the firebox.
10. Install shroud and trim as shown
11. Slide insert back into final position. Do not restrict air flow through vents in the shroud.
12. Route the wiring harness through the cutout on side panel "B"

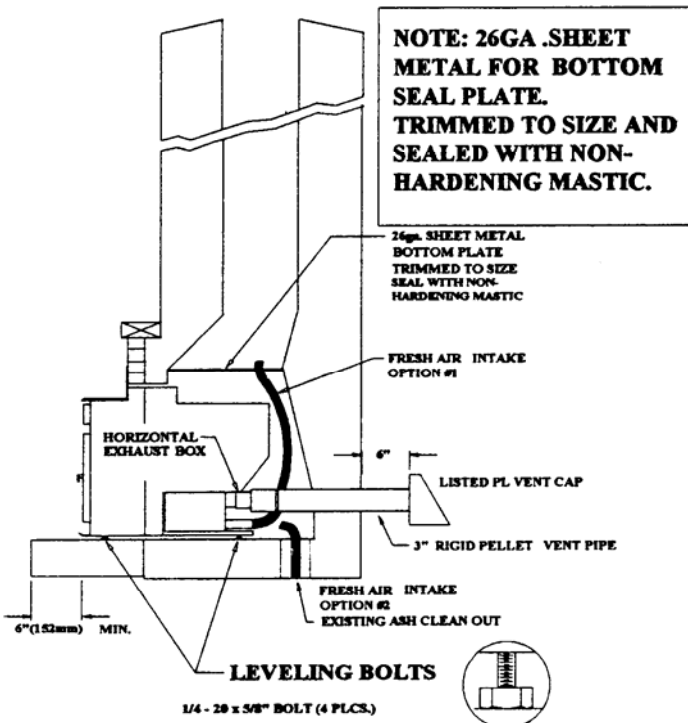

INSTALLATION INSTRUCTIONS....Continued

SHROUD and TRIM INSTALLATION

1. Install shroud top "A" to the stove. Align the top with corresponding holes on stove (see diagram below). Fasten with the # 7 sheet metal screws that are provided.
2. Slide the top lip of side panel "B" & "C" under the Shroud Top "A" and align with corresponding holes. Fasten with the # 7 sheet metal screws that are provided (see diagram below).
3. Attach the trim pieces to the sides and top of shroud. Trim may be cut if necessary.
4. Route the wiring harness through the cutout on side panel "B".
5. Slide insert back into final position. Do not restrict air flow through vents in the shroud.

Do not route power cord under the stove or next to the side of the stove.
Place the power cord behind the side panel and use the "channel" created by the mortar joint between the brick or rock to route the power cord out of the firebox.

Fireplace Insert Shroud Installation Diagram:

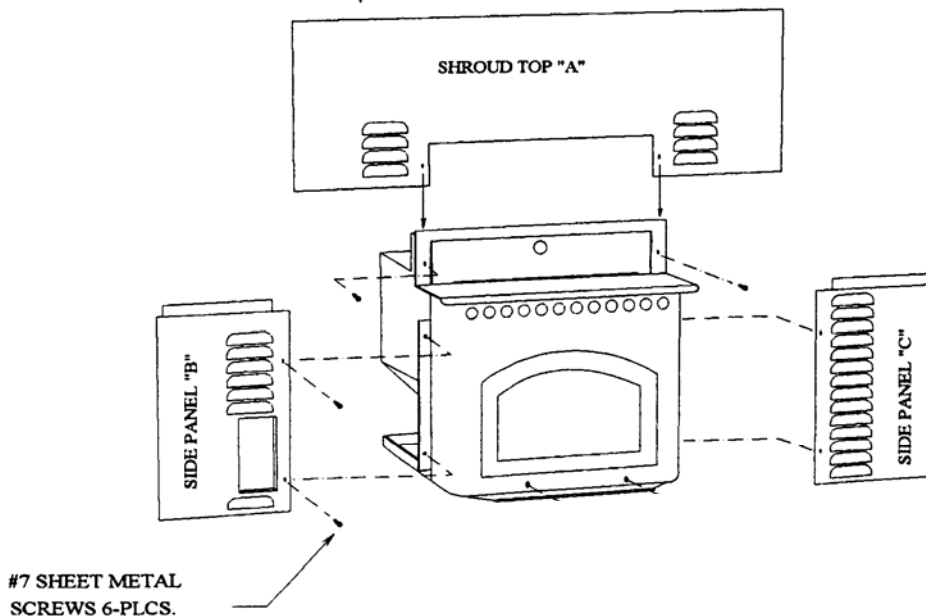

CONTROL PANEL / THERMOSTAT HOOK-UP

WARNING: ALWAYS DISCONNECT POWER CORD DURING ANY ELECTRICAL OPERATION

1. Remove control panel from protective packaging.
2. Connect the one way molex plug to the control panel, do not pull on the wire harness inside the stove.
3. Connect the .250 terminal to the .250 terminal spade on the control panel. Do not pull on the terminal wire inside the stove.

NOTE: Use only a low voltage mercury or bi-metal thermostat switch. (No power required on thermostat)

NOTE: If you are not going to use the thermostat function then skip steps #4 - #8 and go to step #9.

4. Locate the thermostat on a wall six (6') to (10') feet away.
5. Route the wires into the stove near where the AC power cord enters.
6. Pull the thermostat wires through to the control panel cut-out.
7. Move the factory installed jumper from the upper position to the lower position. (see detail below)
8. Connect the thermostat wires to the two terminals on the back of the control panel.
When the room temperature drops below the thermostat setting, the thermostat switch will close, allowing the stove to operate at the medium or higher settings. When the room temperature matches the thermostat setting, the thermostat switch will open, allowing the stove to operate at the low setting.
9. Locate the control panel into the side panel cut-out and secure with four (4) #7 x 1/2 Phillips screws (supplied). Do not over tighten.
10. The stove is now ready for operation. Refer to the OPERATING INSTRUCTIONS.

Note: The thermostat function of the stove will cycle with the room temperature when the "Fuel Feed Control" is set at a medium or higher setting.

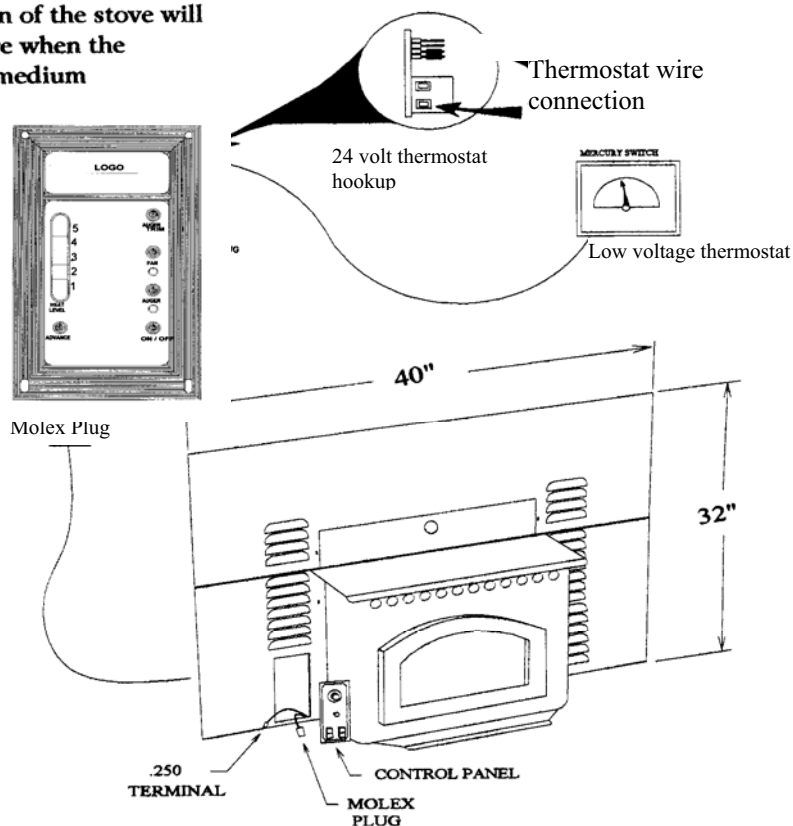

OPTIONAL 12 VOLT BATTERY BACK-UP

WARNING: ALWAYS DISCONNECT POWER CORD DURING ANY ELECTRICAL OPERATION

Note: Never use an unsealed battery.

1. Disconnect the 110 volt AC power before connecting the 12 volt battery.
2. Determine the location for the 12 volt battery and obtain the proper length and type of wire (Use 18 gauge stranded wire)
3. Drill and install 1/2" conduit where passing through a wall or floor.
4. Connect a red 18 gauge wire to red positive (+) battery terminal on the stove.
5. Install a 4 amp inline fuse on the red positive wire near the stove.
6. Connect a black 18 gauge wire to black negative (-) battery terminal on the stove.
7. Pass wire through the conduit to battery location. Allow enough wire length between battery box and exterior wall for a drip loop to prevent moisture from reaching terminals. (see diagram)
8. Connect the red positive (+) lead to the positive (+) battery terminal.
9. Connect the black negative (-) lead to the negative (-) battery terminal.
10. Reconnect the 110 volt AC power. The stove is now ready for 12 volt back-up and will switch automatically to 12 volt operation when AC power is lost. When AC power is restored, the stove will automatically switch back to AC power and recharge the battery.

**NOTE: THE SELF IGNITER WILL NOT START THE STOVE IN THE DC POWER MODE.
(12v Battery Back-up)**

STARTING THE STOVE IN DC POWER MODE (12v Battery Back-up)

1. Clean out and dump the firepot.
2. Pull the air damper rod out to approximately $\frac{1}{4}$ to $\frac{3}{4}$.
3. Turn the "Fuel Feed Control" to the 3rd position.
4. Open the door and add approved fire starter to $\frac{1}{2}$ " of pellets in the firepot and light the fire starter. Once the fire starter is burning freely, close the door.
5. When the pellets are burning well, press the "On/Off" switch to the "On" position.
6. Let the fire continue to build approximately 1 minute, then push the "Start" button.

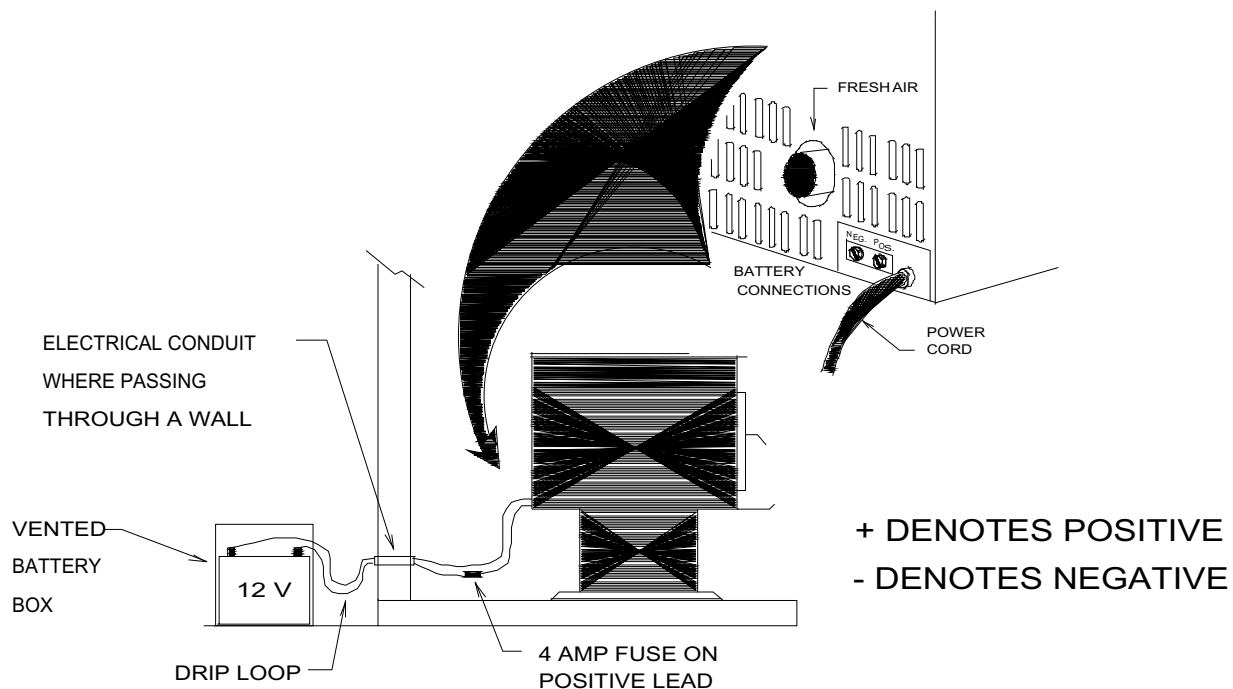

OPERATING INSTRUCTIONS (DC Models)

NOTE: Each time the stove is started, the firepot should be checked for debris and clear air holes. Some fuels will cause the firepot to build up more frequently making it necessary to stir and clean the firepot more often. Do not allow ash to build up underneath the firepot. Take the firepot out at least weekly to vacuum out any ash in the bottom.

PRIMING THE AUGER:

Place Thermostat switch in manual position or turn up wall thermostat to call for heat. Never leave the stove unattended during priming or start-up. Priming the auger is required when the unit is new or when the hopper has completely run out of fuel. Be sure to vacuum out the hopper every 4-6 bags of fuel.

TO PRIME THE AUGER:

- Load the hopper with Fuel.
- Push the “On/Off” switch to the “On” position. Wait about 1 minute.
- Press the “auger” switch button until fuel begins to drop into the firepot. When fuel begins to drop regularly, the auger is primed.

STARTING YOUR STOVE: Place Thermostat switch in manual position or turn up wall thermostat to call for heat.

Note: The viewing door, ash pan door and hopper door must be closed and/or latched during operation.

- Turn the air intake butterfly damper to approximately ¼ open. (located on back of unit)
- If using a DC battery, make sure that all connections are secure. If the unit will not start, the battery (not supplied with unit) may need charging.
- Clean out the firepot; make sure nothing is plugging the igniter.
- Press the “On/Off” switch to the “On” position.

This stove is equipped with a self igniter (optional) that will start Wood Pellets without the use of fire starter. **NOTE: The igniter will not operate if the unit is on DC battery power. You must manually light the unit.**

Fuel will drop into the firepot and ignite in 3-5 minutes. The igniter will continue to run for approximately 10 min until a fire is established. If a fire is not started within the minimum cycle time, the auger will stop feeding and you will need to start the cycle over again.

Pushing and holding the auger switch allows you to prime the auger and add fuel to the firepot automatically. This can be done app. 1 minute after pushing the on/off start button. The unit starts automatically on the low heat setting. When you have started the unit (app. 10 minutes) you can press and hold the heat level button and it will advance one heat setting. Press the button until you have reached the desired heat setting. It is recommended to burn the unit on the number 3 heat setting for the first 30-45 minutes.

The convection blower speed varies directly with the feed rate. The “High Fan” switch will override the variable fan function (# 1 heat setting only). Setting 2-5 is full fan speed.

NOTE: In case of a power outage or interruption lasting longer than 5 seconds, the “Start” button must be pushed to re-engage the auger. The self-igniter will not operate if the unit is on battery power. Manually light the unit.

IMPORTANT: The circuit board will not function properly if the outlet is not a constant 115 volt, 60 cycle power source. The outlet must be grounded properly and have the correct polarity. A polarity and ground tester can be picked up at any hardware store to assure proper operation. If you are using a power generator, solar power or wind generation make sure that you have a constant correct power source.

The unit’s electrical warranty would become void if a constant power source is not available. Also, make sure that a proper surge protector is between the unit and the power source. The circuit board will not be warranted if there is not a surge protector installed to the unit.

It is strongly recommended that you unplug the power source during times when the unit is not being operated to protect the unit from power surges, power spikes and drops in power. It is very common for a circuit board to work when the unit is shut off in the spring and then won’t work in the fall. Unplugging the unit will prevent this from happening.



OPERATING INSTRUCTIONS (AC models)

NOTE: Each time the stove is started, the firepot should be checked for debris and clear air holes. Some fuels will cause the firepot to build up more frequently making it necessary to stir and clean the firepot more often. Do not allow ash to build up underneath the firepot.

PRIMING THE AUGER:

Never leave the stove unattended during priming or start-up. Priming the auger is required when the unit is new or when the hopper has completely run out of fuel. **Be sure to vacuum out the hopper every 4-6 bags of fuel.**

TO PRIME THE AUGER:

- Load the hopper with fuel.
- Push the “On/Off” switch to the “On” position.
- Press the auger override switch until fuel begins to drop into the firepot.
When fuel begins to drop regularly, the auger is primed. You may need to prime the auger a couple times if the fuel has been completely run out. This may take 2 or 3 cycles to light properly.

STARTING YOUR STOVE

Note: The viewing door, ash pan door and hopper door must be closed and/or latched during operation.

- Pull the air damper control rod out to approximately 1/4.
- Clean out and dump the firepot. Place a small amount of fuel in firepot.
- Press the “On/Off” button to initiate the start up sequence.
- Set the heat level on #3. (Press the advance button.)
This stove maybe equipped with a self igniter that will start the pellets without the use of fire starter. Fuel will drop into the firepot and ignite in 3-5 minutes. The igniter will continue to run for approximately 10 min until a fire is established. If a fire is not started within the minimum cycle, the auger will stop feeding.

The auger button allows you to prime the auger and add fuel to the firepot automatically. Press and hold the button until you have the right fuel load.

Do not continue to hold the auger button under normal operation, as it could overload the firepot, smother the fire and lead to a dangerous condition.



The convection blower speed varies directly with the feed rate. The “Fan” button will override the variable fan function when pressed. It will set the convection blower to high at any feed rate setting.

NOTE: In case of a power outage, the pressure switch has tripped, the door has been opened, the hopper door has been left open or any power interruption lasting longer than 5 seconds, the “On/Off” button must be pushed and held for app. 7 seconds (or until you here a click) to re-engage the auger system.

IMPORTANT: The circuit board will not function properly if the outlet is not a constant 115 volt, 60 cycle power source. The outlet must be grounded properly and have the correct polarity. A polarity and ground tester can be picked up at any hardware store to assure proper operation. If you are using a power generator, solar power or wind generation make sure that you have a constant correct power source.

The unit’s electrical warranty would become void if a constant power source is not available. Also make sure that a proper surge protector is between the unit and the power source. The circuit board will not be warranted if there is not a surge protector installed to the unit.

It is strongly recommended that you unplug the power source during times when the unit is not being operated to protect the unit from power surges, power spikes and drops in power. It is very common for a circuit board to work when the unit is shut off in the spring and then won’t work in the fall. Unplugging the unit will prevent this from happening.

OPERATING INSTRUCTIONS...continued (ALL MODELS)

PROPER FUEL

This stove is designed and approved to burn approved Biomass fuel only. Do not use any other type of fuel. Clean corn with moisture content less than 15% must be used. Factory approved pellets are those ¼” in diameter and not over 1” in total length. Larger pellets will cause the auger to jam or bridge in the pellet hopper. The use of unapproved fuel will void all warranties. Do not burn damp or wet pellets. The stove’s performance depends greatly on the quality of your pellet fuel.

Clean fuel means a consistent and trouble-free operation. Do not use corn/wood pellets that have:

1. **Excess fines**-loose material that looks like sawdust or sand. Loading this material into the hopper may eventually slow down or jam the auger and prevent the flow of fuel in the hopper compartment. Dirty Corn (corn cobs, cockle burrs, etc. will plug the auger)
2. **Binders**-material used to hold the pellet together. Wax content corn cannot be used.
3. **High ash content**-avoid pellet brands that immediately smoke up the viewing window and leave a residue in the burn pot. You will be required to clean the ash boxes and vent pipe more frequently. It may be necessary to sample several brands until you find a brand of pellets that will burn properly. Corn supply must be clean, consistent and preferred 11-12% moisture.

RUNNING YOUR STOVE

- A. After starting the stove, leave it burning on the #3 setting for at least 20-30 minutes to allow the stove to heat to operating temperatures. You may then set the desired burn rate by moving the control switch to the desired operating position.
- B. Select the most efficient burn by adjusting the air damper control rod in or out. An air damper closed too much will produce a lazy and slow flame. Adjusted properly, the flames should be bright and lively. Altitude and fuel types greatly affect the amount of air required. Opening the damper approximately ¼-1/2 will be sufficient for most installations and fuels. **The operating temperatures of this unit may vary with the different types or grades of fuel used.**

TURNING THE STOVE OFF

- A. Move the power switch to the “Off” position. (push the On/Off button on the AC & DC models) The fan will continue to run for approximately 45 minutes to let the stove cool down, and then automatically shut itself off.

NOTE: IF THIS UNIT RUNS OUT OF FUEL AND COOLS DOWN, THE AUGER WILL STOP FEEDING. IT WILL BE NECESSARY TO PRIME THE AUGER ANY TIME THE HOPPER RUNS OUT OF FUEL. THE BLOWERS WILL CONTINUE TO RUN UNTIL THE POWER SWITCH IS MOVED TO THE “OFF” POSITION.

WARNING: DO NOT USE ADDITIONAL GRATES TO SUPPORT THE FUEL.

WARNING: Auger jams are the leading cause of stove malfunctions. Jams occur due to foreign objects in the fuel, or more commonly, failure to follow the operating instructions. Most auger jams are preventable by properly priming the auger as required before starting the stove. Keeping the hopper from running out of fuel will help prevent auger jams.

IMPORTANT: Selecting the proper combustion air is done by moving the air damper control rod in or out to decrease or increase the air flow (in = closed = decrease, out = open = increase). High altitude or high ash fuel may require more air for efficient fuel combustion. The stove should be started with the damper control rod out in the 1/4 open position.

CLEANING INSTRUCTIONS

NOTE: BE SURE THE STOVE IS TURNED OFF, THE POWER CORD IS UNPLUGGED, AND THE UNIT IS COLD BEFORE CLEANING OR SERVICING.

RECOMMENDED CLEANING PERIODS:

- A. The heat exchange tubes in the stove should be cleaned daily.
- B. The firebox should be cleaned every 3 to 7 days or when needed.
- C. The interior ash chambers should be inspected and cleaned as needed.
- D. The chimney pipe and cap should be checked monthly for soot buildup.
- E. Combustion blower should be cleaned as needed. Check at least semi-annually.

DISPOSAL OF ASHES:

Ashes should be placed in a metal container with a tight fitting lid. The closed container of ashes should be placed on a noncombustible floor or on the ground, well away from all combustible materials, pending final disposal. If the ashes are disposed by burial in soil or otherwise locally dispersed, they should be retained in the closed container until all cinders have been thoroughly cooled.

WARNING: MANY HOME VACUUM CLEANERS ALLOW ASH TO ESCAPE INTO THE ROOM AIR; HOWEVER, VACUUMING (Use an approved Ash vacuum system.) IS RECOMMENDED OCCASIONALLY TO AID IN SEASONAL CLEANING AND KEEP THE UNIT FREE OF EXCESS ASH. DISCARD THE VACUUM BAG AFTER EACH USE ON THE STOVE.

FIREBOX: This needs to be done every 3-7 days depending on fuel quality, heat settings.

Shut off unit and let cool, open the door, sweep or vacuum out the ash buildup. Remove the firepot and empty, inspect all air holes and clean if blocked. Inspect under the firepot for buildup of ash. Replace the firepot in the stove. Periodically inspect the ash chambers "A", "B", and "C" by removing the inspection doors. If the heat exchangers become plugged remove the three (3) wing nuts, bracket and brick panels. The ash chambers can be removed from the firewall for a more thorough cleaning.

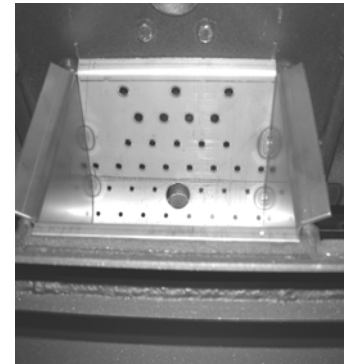
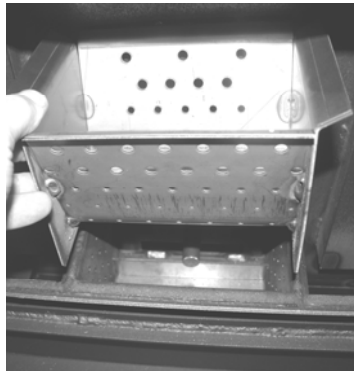

BACK ASH CHAMBER AREA: Every 2-4 weeks Periodically inspect the back ash chambers to make sure that they have not plugged. Contact your local dealer for the proper cleaning tools. Clean out any obstruction that would cause the ash to not drop out of the chamber. There is a clean out plug behind the ash pan that needs to be inspected once a month.

ASH PAN: Empty as needed.

Empty the ash pan before it overflows with ash. Clean out the area that the ash pan sits in so that the ash pan can go back to its original location.

NOTE: The ash pan door must be latched for the unit to operate.

WARNING: Failure to clean the stove is a leading and preventable cause of stove malfunctions. Fuel types and installations may dramatically affect the cleaning intervals required for your stove. Sampling different brands of fuel to find the cleanest burning fuel available in your area can greatly reduce the amount of maintenance required.

HEAT EXCHANGER:

This stove is designed with a built-in heat exchange rake. The rake handle is located on the front of the stove and is moved backwards and forwards several times to remove the buildup of ash. After cleaning, push the rake handle in until it stops.

Ash Rake Handle



COMBUSTION BLOWER:

Over the course of the heating season dust and ash may collect on the blades of the combustion blower. Periodically they should be inspected, vacuumed, and clean. The combustion blower is accessed by opening the stove's right side panel and then removing the inspection caps or the exhaust manifold cover (See figure to the right). Never operate the stove without the inspection cap or manifold cover in place.

200 Manual Reset High Temp Shut Off Auger Thermodisk

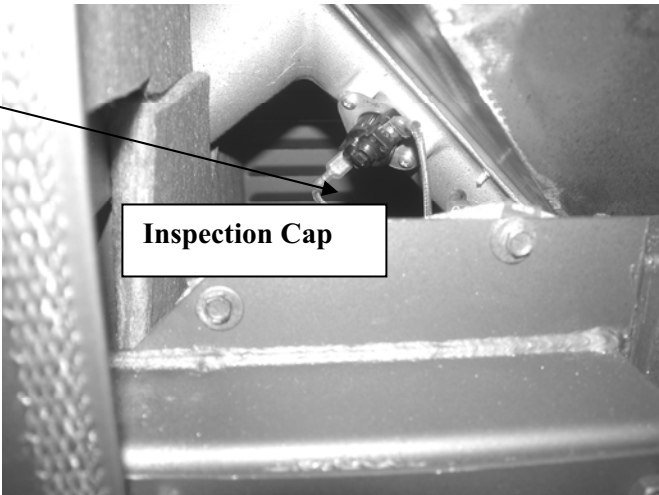

Inspection Cap



Auto Reset 110 deg Normally open Cool Down

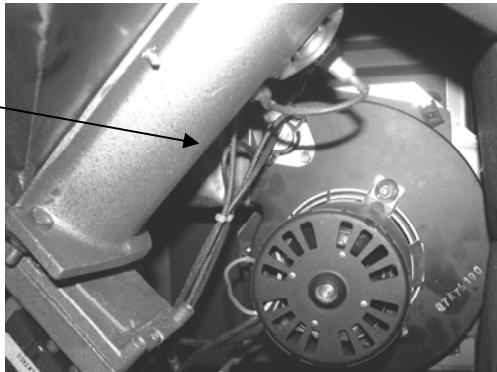

The convection (room air fan) blower will accumulate dust, pet hair, etc. on the blades during the heating season. This must be vacuumed and clean as needed. If you have pets, the convection blower will need to be cleaned regularly as the pet hair will clog up the blades and motor windings and cause premature wear, overheating and failure of the blower system.

CLEANING INSTRUCTIONS FOR THE WIN INSERT

WARNING: DISCONNECT THE POWER CORD BEFORE CLEANING OR SERVICING THIS UNIT. THE STOVE MUST BE TURNED OFF AND COOLED BEFORE USING THE RAKE HANDLE.

II. HEAT EXCHANGER:

This stove is designed with a built-in heat exchange tube rake. The ash rake handle is located on the front of the stove and is moved backwards and forwards several times to remove the buildup of ash. After cleaning, push the rake handle in until it stops.

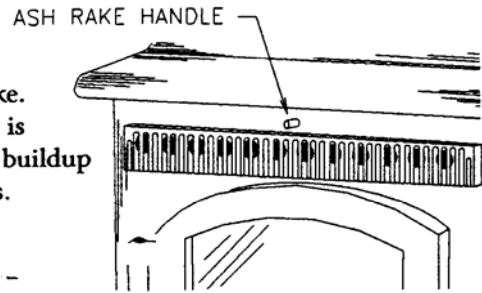

III. COMBUSTION BLOWER:

Over the course of the heating season dust and ash may collect on the blades of the combustion blower. Periodically they should be removed. The combustion blower is accessed by removing the inspection cap (See figure below). Never operate the stove without the inspection cap.

IV. VENT EXHAUST BOX:

The vent exhaust box is accessed by removing the inspection cap (See figure below). Periodically it should be inspected and vacuumed clean.

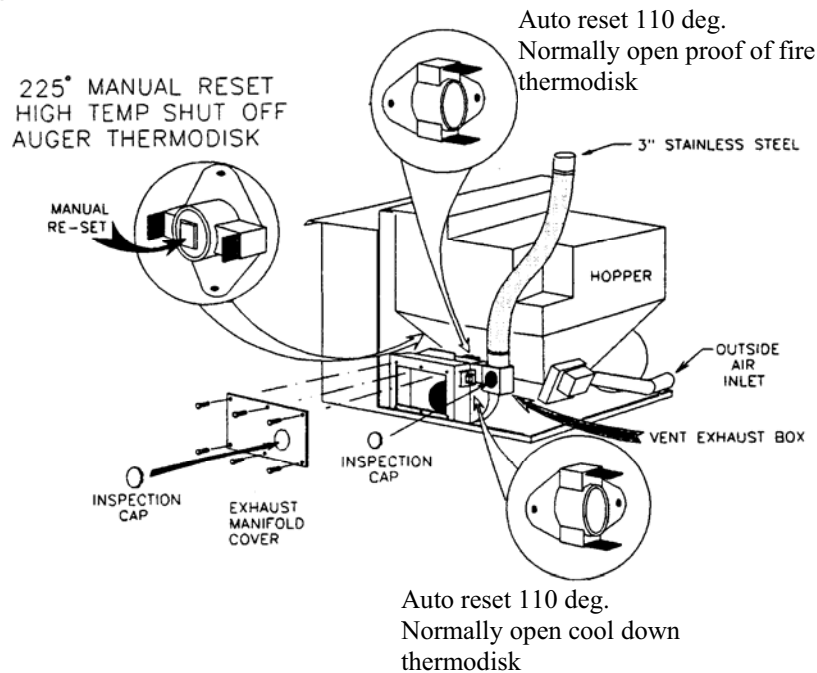

The convection (room air fan) blower will accumulate dust, pet hair, etc. on the blades during the heating season. This must be vacuumed and clean as needed. If you have pets, the convection blower will need to be cleaned regularly as the pet hair will clog up the blades and motor windings and cause premature wear, overheating and failure of the blower system.

INSERT CLEANING INSTRUCTIONS...continued

WARNING: DISCONNECT POWER CORD BEFORE CLEANING OR SERVICING.

NOTE: CLEANING INTERVALS MAY VARY GREATLY WITH DIFFERENT TYPES/BRANDS OF FUEL DUE TO THE ASH CONTENT, MOISTURE, AND MATERIAL COMPOSITION OF DIFFERENT FUELS.

INSPECT AND CLEAN EXHAUST SYSTEM FREQUENTLY

	DAILY	WEEKLY	MONTHLY	ANNUALLY
FIREPOT	Stirred Emptied	SCRAPPED & CLEANED		
FIREBOX (BURN CHAMBER)	CHECKED	CLEANED		
ASH CHAMBERS	CHECKED	CLEANED	EXTRA CLEANING	
EXCHANGER TUBES	CLEANED	EXTRA CLEANING		
COMBUSTION FAN			INSPECTED	CLEANED
VENTING SYSTEM		CHECKED	CLEANED	
GASKETS			INSPECTED	
DOOR GLASS		CLEANED	INSPECTED	

V. CHIMNEY CLEANING:

- A. **Creosote Formation** - Any time wood or a wood product is burned slowly, tar and other bi-products of combustion are produced. These products can condense in a cooled chimney flue and will accumulate over a period of time. It is important to remove these products periodically to eliminate the possibility that they will be ignited in the chimney and produce damage to the chimney or even possibly destroy the home. Clean the chimney as often as needed and never go more than one (1) year without a flue cleaning.
- B. **Soot and Fly Ash - Formation and Need for Removal** - The products of combustion will contain small particles of fly ash. The fly ash will collect in the exhaust venting system and restrict the flow of the flue gases. Incomplete combustion, such as it occurs during startup, shutdown, or incorrect operation of the stove will lead to some soot formation which will collect in the exhaust venting system. The exhaust venting system should be inspected at least once every year to determine if cleaning is necessary.
- C. **Inspection and Removal** - The chimney connector and the chimney should be inspected to eliminate the risk of a chimney fire. Check the chimney from both the top and bottom. The creosote should be removed with a brush designed for your chimney. A chimney sweep can perform this service. It is recommended that before each heating season the entire system be professionally inspected, cleaned, and repaired if necessary.

AUTOMATIC FEATURES

A. THERMOSTAT OPTION (Optional):

When using a thermostat, set the unit to one of the medium or higher settings. The unit will burn at the rate selected on demand by the thermostat (medium to high). When the room temperature drops below the thermostat setting, the thermostat switch will close, allowing the unit to operate at the medium or higher settings. When the room temperature matches the thermostat setting, the thermostat switch will open, allowing the stove to operate at the low setting.

B. THERMOSTAT EQUIPMENT REQUIRED (is optional): A low voltage millivolt thermostat that will automatically switch between settings previously selected. Type CL2 thermostat wire-20 AWG, 2 conductors.

C. VACUUM PRESSURE SWITCH/STOVE PRESSURE SENSOR:

A blocked flue, a down draft, open door, open hopper lid, negative or positive pressure in the home, drafty location of the appliance, not hooking up the outside air, improper venting or maintenance of the 3” inch exhaust venting from the stove will cause the pressure switch to shut off the auger. To resume operation, it is necessary to locate the cause and correct it. Restart the unit following the instructions in this manual.

D. HIGH TEMP THERMODISK/SNAP DISK:

If the unit overheats, it will shut itself down safely. The unit may not be restarted until it has cooled and the reset button is depressed. (See Thermodisk location section) If the auger does not turn after cleaning the back of the unit, you might have tripped this disk. To reset high temp push in on the center button until it clicks into place.

E. SELF-IGNITER (Optional):

Automatically ignites the pellets within 3-5 minutes, without the use of fire starter. The igniter will continue to run for approximately 10 minutes until a fire is established. If the fuel is wet, poor quality or the hopper has not been primed, it might take 2 or 3 cycles for the unit to properly light. Using a small amount of fire starter will help with this.

F. PROOF OF FIRE THERMODISK/SWITCH/SNAP DISK:

If the temperature required by the PROOF OF FIRE thermodisk is not high enough within the 10 (15 minutes on the AC models) minute cycle, the auger will stop feeding fuel.

G. COOL DOWN SENSOR/SWITCH/LOW LIMIT: (Same as Proof of Fire Thermodisk)

After the power switch has been moved to the “OFF” position, the blowers will continue to run for approximately 45 minutes. The cool down sensor will allow the stove to cool down and then automatically shut itself off. If the hopper runs out of fuel and the stove cools off, the auger will stop feeding. However, the blowers will continue to run until the POF switch has cooled down to initiate the shut down cycle

GLASS MAINTENANCE, ADJUSTMENT, REMOVAL AND REPLACEMENT

Your **Magnum Biomass Pellet Stove** comes to you with the glass door installed in place, ready for use. The glass is surrounded on the edges with a gasket and seated in a glass channel. It is held in place with two (2) clips on the top and two (2) clips on the bottom and two (2) clips on each side.

REMOVAL OF BROKEN OR DAMAGED GLASS

Open the door and lift it off of hinges. If the door is tight, tap gently on the bottom of the door with your hand or rubber hammer. Lay door on newspaper with glass clips facing you. Using a #2 Phillips screwdriver, loosen the screws and take the glass clips off. Remove the broken glass carefully and discard. Check to insure that the gasket material under the glass is in working order. You can obtain this material from the factory or from an authorized **Magnum** reseller if it is in need of replacement.

Reverse the above procedure for replacing the new glass. **When installing the new glass insure that the glass is not sitting on top of any obstructions. The glass will break when tightening the screws if the glass is on the gasket. Hold the glass toward the top of the door glass channel when tightening.**

WARNING

**Do no operate unit with broken glass.
Do not substitute original factory glass.
You must use only factory authorized glass:
Do not slam door shut.
Do not strike glass.
Do not use abrasive cleaners.
Do not clean when glass is hot.**

CLEANING THE GLASS

When the fire is first started, it will produce some smoke. The smoke might accumulate on the glass surface. Before the fire gets hot, open the door and wipe the glass surface off with a damp rag. Do not touch the surface with your hands. If after constant use, the glass is dirty; you must clean the glass so that it will not become etched with the fly-ash. When the glass has cooled off, take a damp rag, put a little fly ash from the unit on it and clean the glass. If this does not clean the glass use a special glass cleaner provided by your **Magnum** reseller. **We have found that Amway's Crème Glass & Chrome Cleaner works very well.**

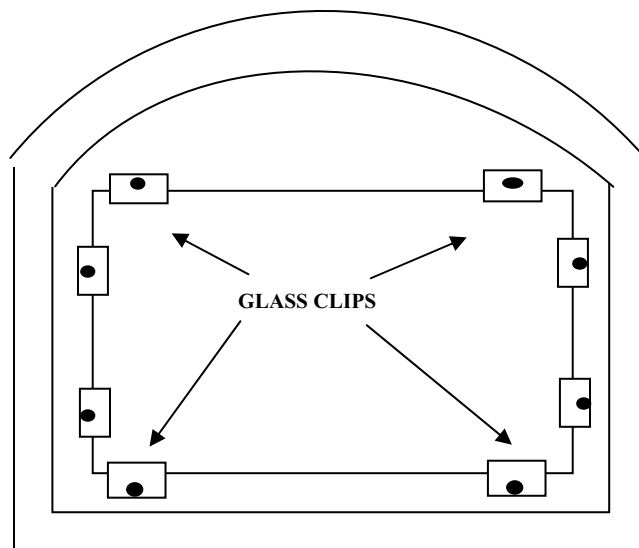

CIRCUIT BOARD/CONTROL BOARD FUNCTIONS (How does the circuit board operate?)

Startup/Normal Operation

When the circuit board is energized (the On/Off button is pushed), the start up cycle is initiated. This starts a timed 8-15 minute cycle which allows the unit to light. If the unit is on AC power, the automatic ignition system will energize. The igniter (optional feature) will glow red in the firepot for 10 minutes and then shut off to protect the igniter. If the unit is on DC back up power the automatic ignition system will not work and the unit will have to be lit manually. If the proof of fire thermodisk has not reached operating temperature, the unit will go into the shut down mode. The circuit board is programmed to start at a specified feed rate regardless of where the heat level setting is set. The unit should be set to the # 2 or #3 heat level setting for the first 45 minutes. To restart the system if it does not light, push the ON/OFF button and the startup sequence will start over again. If you open the door, it will stop the startup sequence.

The circuit board is programmed to start on the # 2 heat setting regardless of what the advance heat setting is on.

NOTE: Make sure that the wall thermostat is turned up so the unit will start. (When using T-STAT or AUTO settings.)

Once the unit is operating at the proper temperature (usually after 10-15 minutes), the circuit board switches from the start up cycle to normal operation. Then the manual draft slide can be set for the right fuel load in the firepot.

The unit is not designed to be operated for long periods of time on the highest heat level setting. Optimum efficiency is achieved by using lower settings (2 or 3). It is also recommended that the unit not be run for extended periods of time on the #1 heat level setting. The draft blower and venting will fill up with fly ash after a period of time. It is recommended to run the unit on a higher # heat level setting (2 or 3) once a week. Run it this way for a few hours to clear the venting and draft blower.

With all models, the manual draft will have to be adjusted when the higher (4-5) heat level settings are used. The circuit board will automatically change the draft and also the room air speed when you change heat level settings.

If you open the door, ash pan door, hopper lid, have negative or positive pressure in the home or place the unit in a drafty location the vacuum pressure switch will shut off the auger and the unit will go into shut down mode. If the unit does not respond, then the pressure switch will have to be re-set by pressing and holding the start button for several seconds, or unplugging the power and starting over again.

Shutdown

To shut the unit down, simply press the On/Off button. The room fan and exhaust blower will continue to operate until the low limit/cool down sensor tells it that the fire is out. At that point the exhaust fan will continue to run for an additional 45 minutes to make sure there is no exhaust in stove.

Before starting the Magnum Biomass unit again, it is important to remember to clean out the firepot, empty the ashes, clean out the heat exchangers, vacuum out the hopper if needed and fill the hopper with fuel.

Basic Circuit Board Functions (expanded)/Diagnostics Operation

The ON/OFF button initiates the start of the circuit board and the shut down of the board. Pushing the ON/OFF button momentarily will engage the start up sequence. The ON/OFF button also is used to re-set the board when the vacuum switch or proof of fire switch is tripped. Pushing the ON/OFF button until the board re-sets (usually 3-5 seconds) will re-establish the system and the fire will continue unless there is a failure in the electrical components.

When you push the ON/OFF button to start the unit, the green light will flash until the start up sequence is complete (app. 10-15 min.). During the start up sequence, the fuel level setting will be overridden and the unit will feed at the #2 fuel rate setting. After the start up sequence has been established (app. 10-15 min.) the unit will run at whatever fuel level setting you selected. The number #2 or #3 heat level setting is recommended.

The auger light will flash when the auger is running. After the first (1) minute of startup, you can hold the auger button down to override the system and manually prime the auger.

The room fan button will override the # 1 heat level setting fan speed and go to high speed. This will not change the fan speed on the #2 - #5 heat level settings.

The auger trim button allows for a low fuel setting fine tune adjustment on the # 1 heat level setting ONLY. When pushing the auger trim button, if the #1 and # 4 heat level setting light is on this indicates the lowest fuel feed setting, when pushing the auger trim button again, if the #1 and #5 heat level setting light is on this indicates the highest fuel setting. If no light is on, this indicates the normal programmed # 1 low heat level setting.

The heat level setting button is a manual heat adjustment. Pushing the heat level setting button will advance the heat settings one level each time that it is pushed. The LED light will show which heat level setting the unit is on. At start up, regardless of where the heat level setting button is set, the unit will feed on the #2 heat level setting. Once the start up sequence has been established, the fuel feed rate setting will run at whatever fuel level setting you selected.

During a short power outage, the board will detect if the proof of fire switch is engaged. If it is still engaged (closed) the unit will auto re-start.

DIAGNOSTICS:

If the proof of fire switch does not close after 15 minutes, the board will shut the igniter and auger feed motor off then it will put the unit into a shut down mode. The # 3 heat level setting led light will flash indicating the proof of fire switch did not close. If the air pressure switch, opens during operation at any time, the system will auto disable the auger motor and/or the igniter. If the switch does not reset during start up, the # 2 heat level setting led light will flash indicating that the air pressure switch is not closed. This will initiate the shut down mode. As of 5/1/07 the following error lights have been added to the DC control panel. Bad auger motor the #1 led light will flash and shut down the system, igniter drawing to many ohms the #4 led light will flash, the system will continue to work but must be checked, high limit switch opens the #5 led light will flash and shut down the unit. If the start up mode fails during the AUTO T-STAT mode, the unit will shut down and require toggling (on/off) of T-STAT to restart.

Your MagnuM comes with the ability to use three (3) separate programming features. This programming must be done by a qualified factory trained technician. Contact your local dealer to set up an appointment to have this done. The unit also has three (3) separate modes of operation (switch located on top of board). The manual setting allows the operator to choose heat level setting changes. The T-STAT setting allows the operator to set the high heat level setting and when the thermostat is satisfied, the unit will automatically go to the low heat level setting. The AUTO setting allows the unit to shut completely off when the thermostat is satisfied and re-start when the thermostat calls for heat. This setting can only be used with wood pellets.

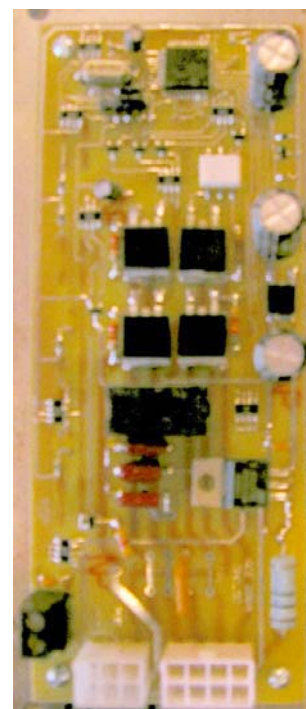

SETTING THE DRAFT

A proper draft setting is crucial to the successful burning of solid fuels. Draft refers to the amount of air flowing through the burn chamber/firebox of your unit. Too much or too little draft will cause your unit to burn improperly and may result in the fire burning out. Please follow these guidelines carefully as you operate your unit to achieve maximum efficiency and enjoyment.

- ✓ The amount of draft required for your unit to burn properly will depend upon your installation and the fuel you use. You can set your draft by looking at the flame and following these guidelines. The manual draft knob is the rod and knob on the left side of the unit. Pulling the knob out increases the draft and pushing the knob in decreases the draft. A little movement of the knob goes a long way to changing the flame. It may take several trial and error adjustments on the draft to achieve the correct setting.
- ✓ The flame should be an “active” flame. A flame that moves around lazily and emits visible smoke needs more draft. To give the fire more draft, pull the damper out 1/8” and check the flame again. If the status of the flame has not changed, move the damper another 1/8” until you get a clean “dancing” flame. **If moving the damper does not change the fire, you might have negative pressure in the home.**
- ✓ The base of the flame should be blue in color and the top of the flame should be white with some yellow.
- ✓ If the flame does not have enough draft, fuel will build up in the firepot and eventually smother the flame. If this happens, or if you notice the firepot is filling up with partially burned fuel, open the damper 1/8” at a time until the fire is clean and dancing. If this continues and moving the draft knob does not change anything, you probably have a negative air problem and should have a service tech inspect your installation. **Do not operate the unit if smoke is being pulled into the home.**
- ✓ If the flame has too much draft, the flame will look like a torch in that it will be moving rapidly and blowing fuel out of the firepot. If you find that you have this condition, move the damper inward 1/8” at a time until the condition of the flame changes.
- ✓ If the fuel crusts over, you will need to check into the fuel quality. This will also be a problem if you do not have outside air hooked up or if your home is starving for fresh air.

AC MODEL WIRING DIAGRAM

WARNING: DISCONNECT POWER BEFORE SERVICING THIS UNIT.

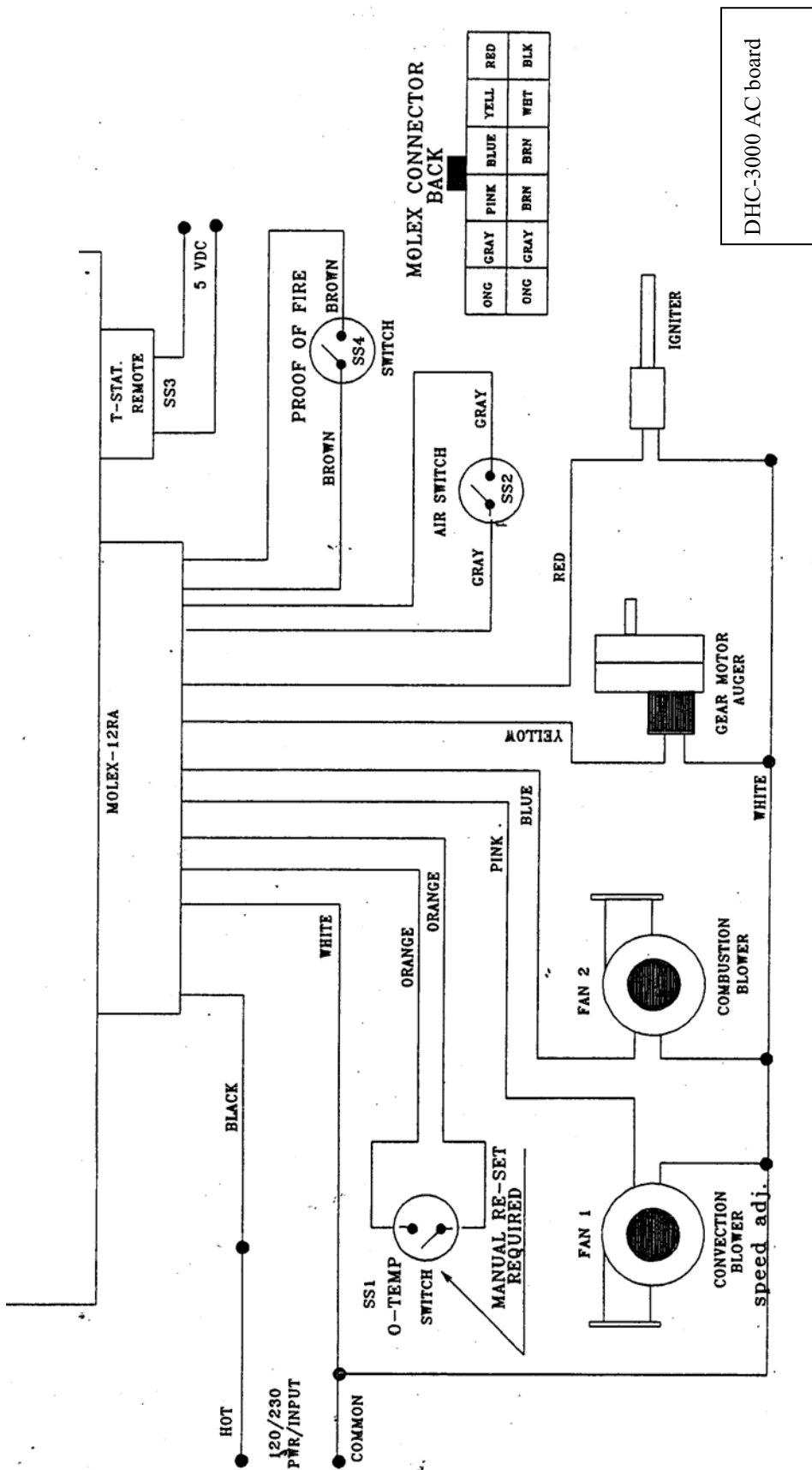

DC MODEL DDC-3000 WIRING DIAGRAM

WARNING: DISCONNECT POWER BEFORE SERVICING THIS UNIT

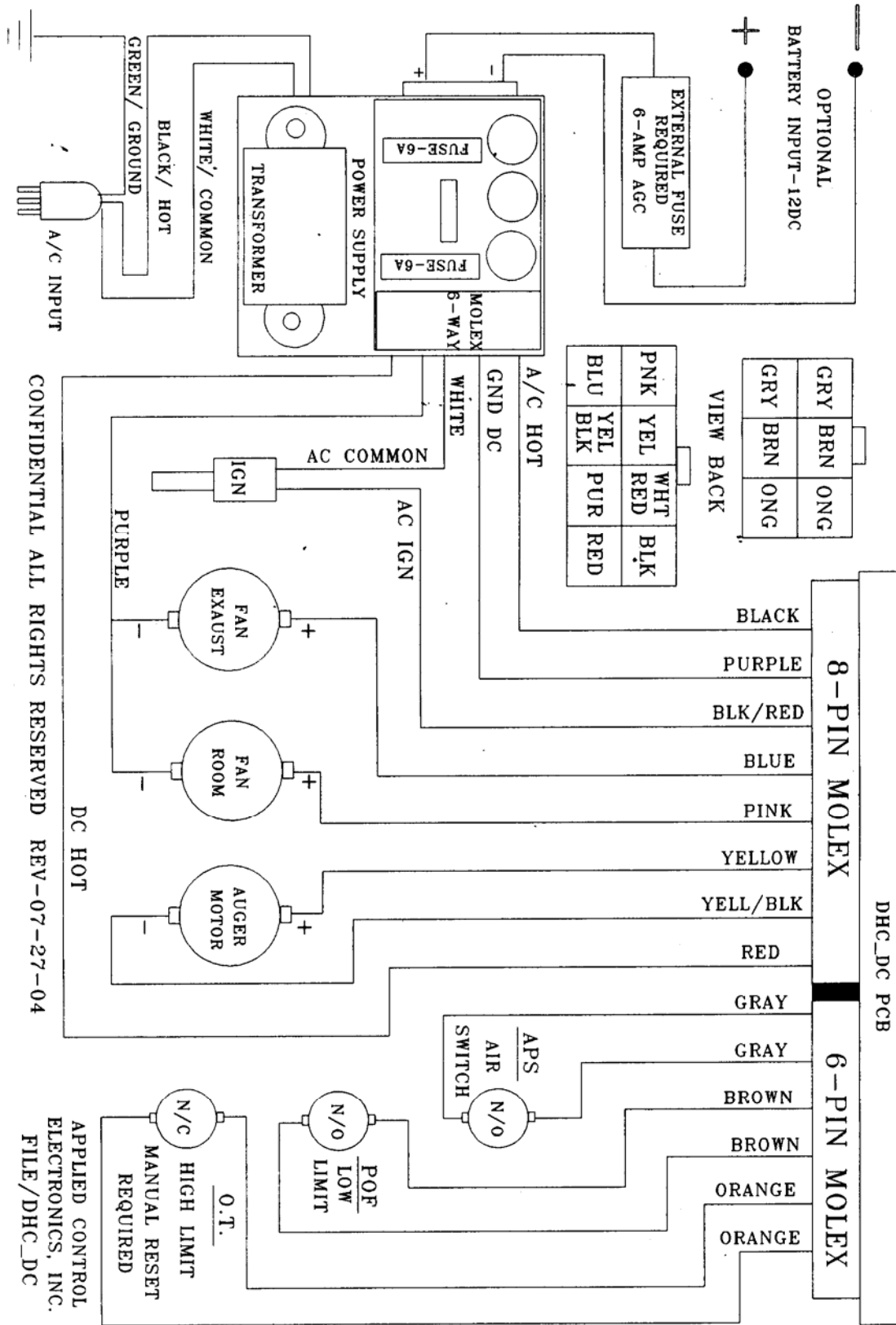

CONFIDENTIAL ALL RIGHTS RESERVED REV-07-27-04

APPLIED CONTROL ELECTRONICS, INC. FILE/DHC_DC

OPTIONAL SOLAR PANEL CONNECTIONS

WARNING: Use a 3 AMP, 50 volt diode on the “+” positive lead between the solar panel and battery as shown in the diagram below.

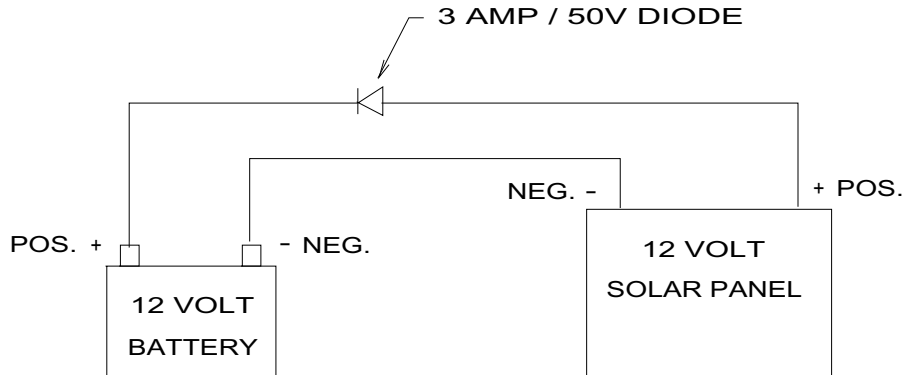

DRAFT SLIDE GATE ADJUSTMENT

NOTE: Draft Slide Gate does not come with unit. This is a add-on only done by a qualified technician

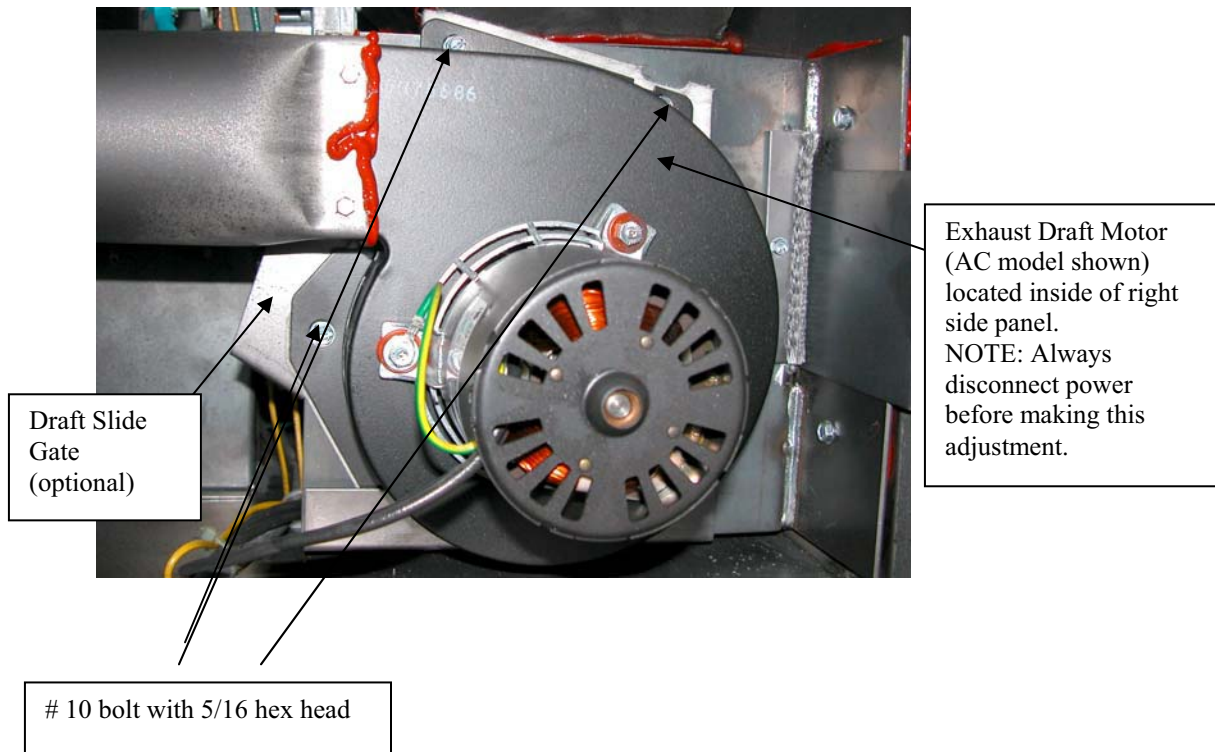

The normal operation of the Magnum appliances would be with the Draft Slide Gate open fully as shown. When the gate is in the fully open position, the plate will be against the mounting plate as shown.

If the unit needs a draft correction adjustment, loosen the bolts (see above) and then rotate the slide gate a few degrees at a time until the proper operation of the unit is achieved.

NOTE: This adjustment must be made by a qualified Magnum Service Technician.

When rotating the slide gate, be careful not to damage the gasket. Re-tighten the bolts and check for leaks.

IGNITER REPLACEMENT

The igniter system on the Magnum appliances' is an integral part of the wiring system. If the igniter is shorted out, the wiring must be disconnected in order for the unit to operate. If the wires are by-passed it will cause the stove to short out and blow a fuse. It is recommended that once a season the igniter is checked for proper operation and replaced if it does not glow red.

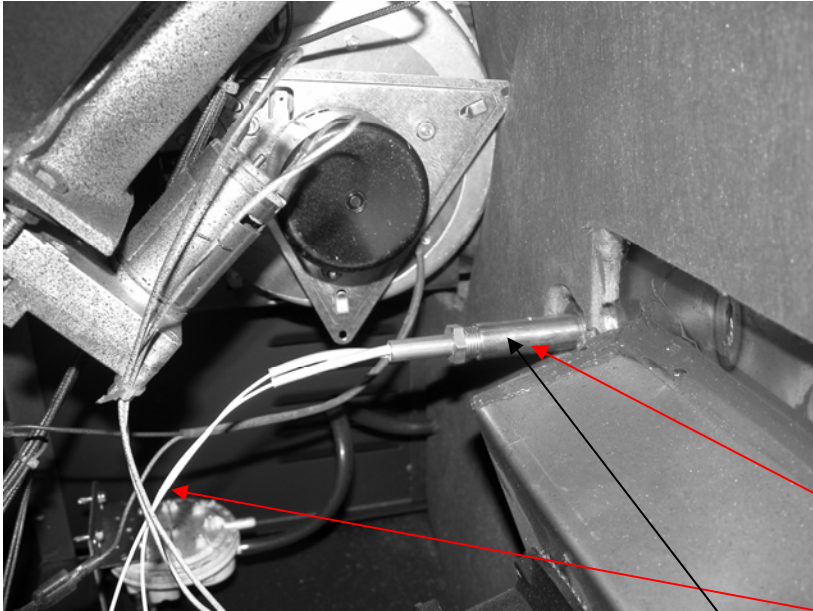

Access to the igniter assembly, can be made by opening the left side panel. The power must be disconnected, check that you do not pull on the wiring, when taking out the circuit board. Take special care not to cut yourself or damage wiring.

Use two (2) pliers or needle nose pliers to take the wire terminals apart. Be careful not to pull the wire out of the terminal ends as they are tight.

Ignitor

Wires for Igniter

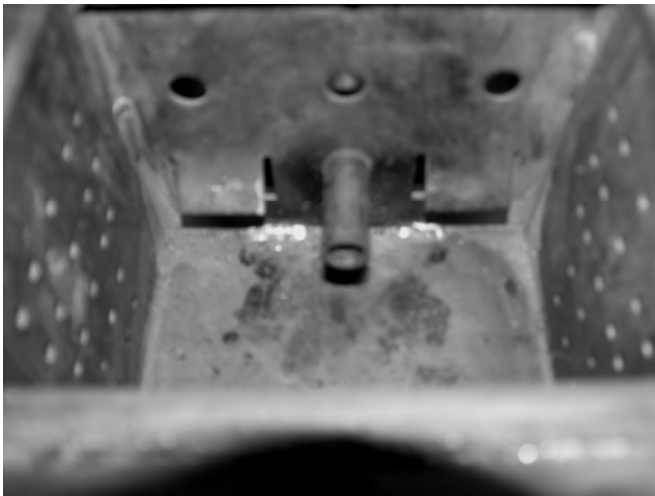

The igniter assembly is threaded, turn counter clockwise to loosen. You will be able to slide the igniter out the back if the end of the igniter in the firepot is not deformed. If the igniter will not slide out the back, you will need to work the igniter back and forth to dislodge any buildup.

Remove the firepot from the unit to access the igniter end. When installing the new igniter, hand tighten the igniter and then apply slight pressure to secure the threads. Do not over tighten the igniter assembly.

If you over tighten the igniter assembly it may ruin the igniter. Crimp and attach the terminal ends to the wiring harness. If you do not have a terminal crimping tool, you will need to get one from a hardware store. Igniters are a consumable item and will need to be replaced periodically.

Do not attempt to take the igniter out of the unit while the unit is plugged into power or if the igniter is hot.

TROUBLE SHOOTING GUIDE

Unplug power to the appliance before performing any service.

PROBLEM	CAUSES	SOLUTIONS
<p>? Fire burns with a lazy, orange flame and/or fuel builds up in the firepot and the glass will soot up quickly.</p>	<ul style="list-style-type: none"> ◆ Insufficient combustion air. ◆ Feed rate too high for manual draft setting. ◆ Fuel has too much moisture, has too many fines, too high of ash content or is old. ◆ Combustion/Exhaust blower plugged or going out. ◆ Venting plugged with fly ash or ice. ◆ Home does not have adequate make up air (negative pressure). ◆ Ash slides are pulled out. 	<ul style="list-style-type: none"> ✓ Remove any clinkers or ash from the firepot by using scraping tool. Clean entire system. ✓ Clean out primary air in firepot holes if plugged. ✓ Empty ash drawer. Clean out heat exchangers by removing the access plates. ✓ Change to a better grade of fuel if necessary. ✓ Check that damper control knob is adjusted properly. Pull out to increase fire burn. ✓ Push ash cleanout slides in. ✓ Check gasket seal around the door. If the door is loose, adjust the handle latch. A small adjustment can be made to the door seal by adjusting the door latch rod and/or the door hinges. Replace the door gasket if necessary. ✓ Check for blockage in the air inlet tube or exhaust pipe. Clean out as needed. ✓ Check combustion/exhaust blower impeller. This can be done by removing the exhaust pipe and shining a light into the tube or using the access plug on the exhaust manifold side plate. ✓ Replace combustion/exhaust blower if needed. <p>NOTE: Negative pressure in a home is a serious issue. All MagnuM appliances should be installed with outside air hookups.</p> <p>Also, make sure that adequate ventilation is supplied for the rest of the home, or the unit will become the air intake causing problems.</p>

PROBLEM	CAUSES	SOLUTIONS
<p>? Fire goes out or stove shuts down automatically.</p>	<ul style="list-style-type: none"> ◆ Hopper is empty. ◆ Fuel is not feeding. ◆ High limit temperature switch has tripped. ◆ Vacuum pressure switch has tripped. ◆ Poor quality or wet fuel. ◆ Combustion air too high. ◆ Fuel feed rate is too low. 	<ul style="list-style-type: none"> ✓ Refill hopper. ✓ See “Fuel will not feed” below. ✓ Allow stove to cool for 1 hour and relight after re-setting the high temperature thermodisk. If this problem persists, particularly at lower burn rates, then the high limit snap switch may need to be replaced contact your authorized Magnum reseller. ✓ Correct cause of vacuum pressure switch tripping. Have an authorized tech service unit. Install outside air. ✓ Replace fuel with proper fuel. ✓ Adjust the damper to reduce combustion airflow. ✓ Have your Magnum reseller adjust the fuel control.
<p>? Fuel will not feed.</p>	<ul style="list-style-type: none"> ◆ Hopper is empty. ◆ Auger, circuit board, high limit switch tripped. ◆ Foreign object caught in auger. ◆ Fuel is dirty or wet. ◆ Auger, circuit board, pressure switch or relay. 	<ul style="list-style-type: none"> ✓ Check contents of the hopper. Add fuel if necessary. ✓ Check all operations, fuses, re-set manual high limit thermodisk. ✓ Clean out auger system. ✓ Have your Magnum reseller diagnose the problem and replace parts if needed.
<p>? Stove runs for 10 minutes and then shuts down.</p>	<ul style="list-style-type: none"> ◆ Exhaust gas is not up to temperature. Started on too low of heat level setting. Must be on # 3 heat level setting. ◆ Low limit snap switch not operating correctly; may be defective. ◆ Wires to either the low limit snap switch (mounted on the side of the firebox) are loose or disconnected. 	<ul style="list-style-type: none"> ✓ Relight the stove. Start on # 3 heat level setting. ✓ Have your Magnum reseller replace the low limit switch. ✓ Contact your Magnum reseller for service.
<p>? Blower will not shut off after the fuel has been switched off and the stove has cooled down.</p>	<ul style="list-style-type: none"> ◆ Low limit snap switch has failed in the closed position. ◆ Unit has not cooled down yet. 	<ul style="list-style-type: none"> ✓ Have your Magnum reseller replace the low limit snap switch. ✓ It can take up to 1 hour for the unit to cool down enough for the blower to shut off. If it takes longer than 2 hours for the blower to shut off or if it fails to shut off contact your local Magnum service technician.

PROBLEM	CAUSES	SOLUTIONS
<p>? Room blower will not operate.</p>	<ul style="list-style-type: none"> ◆ No power to stove. ◆ No power to control board. ◆ Blower has overheated due to dirt on blades or in motor. ◆ Blower is defective. 	<ul style="list-style-type: none"> ✓ Check to see that the unit is plugged into the wall outlet. ✓ Check to see if your circuit breaker has “tripped”. ✓ Clean blades and motor, have a Magnum tech replace blower if needed.
<p>? Soot or fly ash in the house.</p>	<ul style="list-style-type: none"> ◆ Cleaning the glass, particularly when the unit is operating. ◆ Leakage on the joints between the combustion fan, exhaust pipe and “PL” vent. This will be evident by dust on the heat exchanger tubes and the impeller of the room fan. ◆ Using a conventional vacuum for cleaning. Ash will bypass the filter and enter the room. ◆ Negative pressure in home sucking ash/soot out of venting and unit. ◆ Fireplace insert installation: If the existing fireplace opening was not thoroughly cleaned and painted before the insert was installed, then the room fan may be picking up the fireplace dust, soot or ash and blowing it into the home. 	<ul style="list-style-type: none"> ✓ Clean the glass when the unit is not running. ✓ Seal any leaks in the exhaust system with RTV high temperature silicone sealer. ✓ Use approved ash vacuum. ✓ Correct negative pressure situation. ✓ Pull the insert away from the fireplace opening. Thoroughly clean the opening and paint the inside of the opening with latex or an inexpensive spray paint to hold the finer particles of dust.
<p>? Buildup of soot on glass, venting and heat exchangers.</p>	<ul style="list-style-type: none"> ◆ Dirty fuel. ◆ Inadequate air supply. ◆ Negative pressure in home. ◆ Air wash plugged or out of adjustment. 	<ul style="list-style-type: none"> ✓ Make sure you use clean fuel. ✓ Pull manual draft control out slightly to insure there is app. ½ inch of fuel in firepot. ✓ Install outside air to unit. Verify home has adequate make-up air. (Suggested 6” make-up air into home.) ✓ Clean air-wash located on bottom of glass door.

CAUTION: When performing any internal electrical maintenance

- Moving parts inside of the cabinet may cause injury.
- HOT parts. Do not operate the unit with panel open.
- Risk of electrical shock. Disconnect power before servicing unit.
- In the event of component failure, replace with original factory equipment.

IMPORTANT: Electrical work must be performed by a Factory authorized technician.

PROBLEM	CAUSES	SOLUTIONS
<p>? Fuel burns off to quickly, have difficulty keeping a pilot fire.</p>	<ul style="list-style-type: none"> ◆ Air shutter is open to far. ◆ Over drafting on a vertical install. ◆ Outside air is not hooked up. ◆ Positive or negative pressure in home is affecting the units operation. 	<ul style="list-style-type: none"> ✓ Adjust your air damper to a more closed position. ✓ A chimney restrictor may need to be installed. Consult with your Magnum dealer. ✓ Make sure that the installation is correct and nothing is affecting the furnace room.
<p>? Foreign object caught in the auger and will not turn.</p>	<ul style="list-style-type: none"> ◆ Accidental object in fuel. 	<ul style="list-style-type: none"> ✓ If there still is a fire, let it extinguish and let the unit cool down. Unplug unit after the fire has exhausted. It will be necessary to clean out hopper. As you are facing the unit open the right side panel. ✓ Take the auger motor off and gently turn the auger backwards until the object is free. ✓ If you cannot get the object loose, contact your Magnum Reseller.
<p>? Getting to much ash.</p>	<ul style="list-style-type: none"> ◆ Dirty fuel. ◆ Wet fuel. ◆ Lack of clean combustion air. ◆ Dirty or plugged stove or venting. Poor exhaust vent configuration. ◆ Negative pressure present in the home. ◆ Exhaust fan motor going out. ◆ Use combustion enhancement system. 	<ul style="list-style-type: none"> ✓ Dirty, wet fuel will produce excessive ash. ✓ Obtain quality fuel. ✓ Take proper steps to protect fuel from the elements to not take on moisture. ✓ Check air damper and check combustion air inlet for obstructions. ✓ Check all cleanouts and exhaust venting for obstructions. Refer to cleaning section of this manual. ✓ Call your Magnum reseller to inspect the installation, operation and replace any bad parts if necessary.
<p>? The heat output is not as high as when the unit was installed.</p>	<ul style="list-style-type: none"> ◆ Wet or dirty fuel. ◆ Inadequate cleaning. ◆ Change of fuel to lower BTU value. ◆ Negative pressure or improper fresh air make up system. 	<ul style="list-style-type: none"> ✓ Wet fuel has a much lower BTU output. Dirty fuel does not produce adequate heat. Excessive amounts of fines interrupt the amount of fuel delivered for burning and will decrease heat output. ✓ Clean heat exchangers daily, inspect unit for proper air flow. ✓ Have your Magnum dealer check for proper installation and negative pressure in the home.

MAGNUM WINCHESTER APPLIANCES REPLACEMENT PARTS LIST

ORDER #	MODEL NAME/DESCRIPTION	Dealer Pricing	MSRP
BC2500	MagnuM Baby Countryside Auto-Light system, complete assembly		
BC2009	Igniter, Baby Countryside		
RP2010	MagnuM Baby Countryside, Win, Essex DC Power Supply RPS-300		
RP2004DC3	MagnuM Baby Countryside, WIN, Essex Control Board (DC)		
RP2007	MagnuM Baby Countryside Circuit Board (Digital electronic board)		
P1315	4 ¾" diameter draft blower blade (located in draft blower housing)		
P1316	3" diameter blade for DC Combustion (draft) blower		
RP2100	Door Gasket (separate) per foot (specify WIN or Essex)		
RP2020	MagnuM Baby Countryside, WIN, Essex, Avent DC 2 rpm Auger Motor		
RP2022	MagnuM Baby Countryside, WIN AC 2 rpm Auger Motor		
RP2025	MagnuM Baby Countryside, WIN, Essex DC Combustion (draft) Blower Motor (Motor Only)		
RP2026	WIN, Essex DC Combustion (draft) Blower Motor support plate		
RP2027	WIN, Essex DC Combustion (draft) Blower (complete assembly)		
RP2030	MagnuM Baby Countryside, WIN AC Combustion Blower (complete assembly)		
RP2035	MagnuM Baby Countryside, WIN, Essex, Avent DC Room Fan		
MF3541	MagnuM Baby Countryside, WIN AC Convection blower		
RP2045	F-110 N/O POF Switch (interchangeable with F-140 & F-150)		
RP2050	L-225 N/C Switch (manual reset) MagnuM Baby C/S, WIN / Essex		
RT080	MagnuM Baby Countryside, WIN, Essex, Hopper Pressure Switch		
RP2099	Glass Gasket (separate) per foot (specify WIN or Essex)		
RP2063	MagnuM Baby Countryside, AC unit Wire Harness assembly		
RP2062	MagnuM Baby Countryside DC unit Wire Harness assembly		
RP2098	MagnuM Baby Countryside / WIN / Essex Arched Glass (w/gasket)		
	Gold Grill assembly (separate)		
	Nickel Grill Assembly (separate)		
RP2087	MagnuM Baby Countryside, Essex Black Trivet (separate)		
RP2088	MagnuM Baby Countryside, Essex Gold Trivet (separate)		
RP2089	MagnuM Baby Countryside, Essex Nickel Trivet (separate)		
RP2090	MagnuM Baby Countryside, WIN, Essex, Avent Auger Assembly		
	NOTE: RP2090 used on some models, RP2090-P400 used on newer models. Provide serial number when ordering		
RP2091	Auger Bushing (set)		
P1155	Heat Exchanger Rake Handle		
RP2093	Damper Spring Handle		
RP2096	Neoprene Hose ¼" ID Hose (per foot)		
RP2097	Door Handle Assembly		
RP2001	WIN Brick Panel, Left		
RP2002	WIN Brick Panel, Right		
RP2065	WIN Gold Door Finish (only) (re-finish gold door)		
RP2070	WIN Gold Door (complete door assembly)		
RP2072	WIN Black Door (complete door assembly)		

5 YEAR LIMITED WARRANTY

This warranty is issued by American Energy Systems, Inc. (Manufacturer) and extends only to the original purchaser of this product.

This limited warranty will not become effective unless you have returned the attached warranty card within 30 days of your purchase. If you fail to do so, you may make no claim under this warranty. American Energy Systems, Inc. excludes and disclaims all implied warranties including, but not limited to, the implied warranty of merchantability.

For a period of (five) 5 years from the original purchase, Manufacturer will warrant, to the original consumer-purchaser, that all steel components are free from defects in materials and workmanship (except the firepot, which has a lifetime warranty and glass which carries a lifetime warranty against heat breakage). There is expressly no warranty on the fiberglass rope gasketing, pyroboard insulation (brick backing), log sets, paint, brass or gold plated surfaces, baffles or handles.

The original manufacturer covers all electrical components, for a period of one year from the original purchase date.

There is no warranty coverage for variances in fuel feed rates. BTU heat ratings will vary with different fuel conditions and is not considered a defect if the unit does not feed a constant amount of fuel.

The warranty covers defects in materials and workmanship in covered components, provided the product has been installed and operated strictly in accordance with manufacturers printed instructions. This warranty does not cover damage or breakage due or caused by mishandling, freight damage or misuse or unauthorized modification of the structure or electrical system.

This warranty will become null and void if unauthorized fuel is used.

This warranty will become null and void if outside air is not connected to the appliance.

This warranty will become null and void if the appliance is not installed according to the guidelines and requirements of this manual along with proper venting and operation of the appliance.

Before exercising this warranty, a local representative must inspect the unit to determine if the unit is defective. If the inspection reveals that the failure is due to defective material or workmanship and the part is covered by the condition of this warranty, the Manufacturer will, at its option, repair or replace the defective part. The sole duty of the Manufacturer and liability under this warranty is limited to the repair or replacement of the covered defective part. The purchaser shall assume all costs related to shipping the replacement parts or return of the unit to the factory for replacement. If it is determined that the defect was caused by the Manufacturer, the Manufacturer will cover the costs of shipping the repaired unit or replacement parts to the original purchaser.

REMOVAL OR REINSTALLATION COSTS ARE NOT COVERED BY THIS WARRANTY.

Neither the Manufacturer, nor the Reseller to the purchaser, accepts responsibility, legal or otherwise, for incidental or consequential damage to property of persons resulting from the use of this product. Any warranty implied by law, including but not limited to implied warranties of merchantability or fitness, shall be limited to one year from the date of original purchase. Whether a claim is made against the Manufacturer based on a breach of this warranty or any other type of warranty, expressed or implied by law, Manufacturer shall in no event be liable for any special, indirect, consequential or other damages of any nature whatsoever in excess of the original purchase price of this product. All warranties by Manufacturer are set forth herein and no claim shall be made against Manufacturer on any oral warranty or representation.

THE MANUFACTURER WILL NOT BE LIABLE FOR ANY DAMAGE RESULTING FROM THIS APPLIANCE BEING INSTALLED BY A NON-CERTIFIED/FACTORY TRAINED INSTALLER

Some states do not allow the exclusion or limitation of consequential damages, or limitations of implied warranties, so the limitations or exclusions set forth in this warranty may not apply to you. This warranty gives you specific legal rights and you may also have other rights, which vary, from state to state.

Warranty/replacement parts must be handled through the dealer that sold you your appliance.

ALL CLAIMS NOT HANDLED THROUGH YOUR LOCAL DEALER UNDER THIS WARRANTY MUST BE MADE IN WRITING TO THE MANUFACTURER AT:

AMERICAN ENERGY SYSTEMS, INC., 150 Michigan Street SE, Hutchinson, Minnesota 55350

Technical Support telephone number 320-234-0743

Included with the claim needs to be the following:

Name, address and telephone number of local reseller or representative.

Name, address and telephone number of the original purchaser.

Name, address and telephone number of the installer

Date of purchase along with the model and serial number of the unit.

Nature of defect and procedures of what has been done to correct the problem. **(unit must be checked out by the dealer that sold you the unit before submitting warranty replacement parts.)**

SERVICE RECORD

DATE	SERVICE OR CLEANING PERFORMED

This record must be sent in when any warranty claims are made.