

MAGNUM COUNTRYSIDE®

BIOMASS CORN/WOOD PELLET STOVE /FIREPLACE INSERT

Safety tested and EPA exemption tested by Omni-Test Laboratories, Inc to UL 1482, CAN/ULC-S627, ULC-S628, APFI requirements, Oregon administrative rules 814-23-900 to 814-23-909 and E.P.A. Method 28A.

OWNER'S MANUAL

Installation – Operation – Maintenance Instructions

NOTE: These instructions must be saved

PLEASE READ THIS ENTIRE MANUAL BEFORE INSTALLATION AND USE OF THIS BIOMASS CORN/WOOD PELLET BURNING STOVE. FAILURE TO FOLLOW THESE INSTRUCTIONS MAY RESULT IN PROPERTY DAMAGE, BODILY INJURY OR EVEN DEATH.

IMPORTANT: Always contact your local dealer/installer with questions before contacting the factory.

When you call have your serial number, purchase date, who installed the unit and a list of questions.

This appliance must be installed by a qualified/trained factory approved installer to assure proper operation/warranty.

- ✓ When installing your **Countryside Biomass Corn/Pellet** stove, particular attention needs to be made in regards to fire protection. If the unit is not properly installed, a house fire may result. For your safety, follow the installation and operation instructions provided, and if a question arises contact local building or fire officials about restrictions and installation requirements in your area.
- ✓ Read the operations and fuel section of this manual before plugging in your unit.
- ✓ Always unplug the unit before attempting any service work.
- ✓ Do not connect the unit to a chimney flue already serving another appliance.
- ✓ When installing the chimney pipe to the unit, it is important to remember that the unit operates on a negative pressure and the chimney on a positive pressure. All chimney connections, elbows and fittings must be airtight. **(proper venting practices must be followed. Consult with a venting professional)**
- ✓ Ashes must be disposed of in a metal container with a tight fitting lid.
- ✓ All minimum clearances to combustibles must be followed.
- ✓ The **Countryside Biomass Corn/Pellet Stove** is tested for operation with 14% or less moisture corn or with wood pellets with an ash content of no more than 3%. **It is recommended that Corn with 11-12% moisture or wood pellets with an ash content of 1% or less be used for efficient operation of this unit. Corn over 12% moisture has a lower BTU value and will be hard to burn on the lower settings.**
- ✓ **It is important to use fuel that is clean, dry and consistent.** Make sure that your supplier is giving you the same fuel each time that you purchase. It is recommended that you purchase your entire heating season supply of fuel at one time so that the fuel will be the same.
- ✓ **A voltage surge protector or ground fault outlet is required for this unit. The electrical warranty will be voided if surge protection is not installed before operating this unit.**
- ✓ **A grounded outlet must be provided with proper polarity. A constant 115 volt, 60 cycles must be provided for proper operation or the warranty of this appliance will be forfeited.**
- ✓ **DISCLAIMER NOTICE:** No guarantee is made regarding the heating capacity of this product. The actual area that this unit will heat depends on factors such as building conditions, heat loss, type of construction, amount and type of insulation, type of air movement and heat distribution and the location of the product.
- ✓ **IMPORTANT:** Your home must be checked to verify that there is no negative pressure that will effect the operation of this appliance.

AMERICAN ENERGY SYSTEMS, INC. GRANTS NO WARRANTY, IMPLIED OR STATED, FOR THE INSTALLATION OR MAINTENANCE OF THE STOVE AND ASSUMES NO RESPONSIBILITY FOR ANY CONSEQUENTIAL DAMAGE(S).

AMERICAN ENERGY SYSTEMS, INC. -150 Michigan Street SE - HUTCHINSON, MINNESOTA 55350

Web Site: www.hearthdirect.com

Rev. date 08/06

TABLE OF CONTENTS

	PAGE
CLEAN BURN (special additive)	3
INTRODUCTION & SPECIFICATIONS.....	4
IMPORTANCE OF ADEQUATE FRESH AIR.....	5
SAFETY STEPS.....	6
BURNING SOLID FUELS (SHELLED CORN/WOOD PELLETS).....	7-8
UNPACKING YOUR COUNTRYSIDE STOVE.....	8
INSTALLATION REQUIREMENTS (FLOOR PROTECTION).....	9
CLEARANCES TO COMBUSTIBLES.....	10
GUIDELINES FOR EXHAUST SYSTEMS DESIGNS.....	11-12
DESIGN GUIDELINES FOR OUTSIDE COMBUSTION AIR CONNECTION.....	13
INSTALLATION PRECAUTIONS.....	14
VENT TERMINATION GENERAL INSTRUCTIONS.....	15
INSTALLATION CONFIGURATIONS.....	16
ALCOVE INSTALLATION REQUIREMENTS.....	17
FREESTANDING STOVE INSTALLATION CONFIGURATIONS.....	18-20
FIREPLACE INSERT INSTALLATION CONFIGURATIONS.....	21-22
GLASS MAINTENANCE.....	23
STOVE CONTROLS.....	24
LIGHTING INSTRUCTIONS.....	25
CIRCUIT BOARD FUNCTIONS.....	26
SETTING THE DRAFT.....	27
MAINTENANCE INSTRUCTIONS.....	27-30
AUTOMATIC SAFETY FEATURES.....	31
HOPPER AUGER SAFETY SWITCH LOCATION.....	32
THERMOSTAT INSTALLATION.....	33
TROUBLE SHOOTING GUIDE.....	34-37
WIRING DIAGRAM.....	38
SETTING THE CIRCUIT BOARD.....	39
DRAFT SLIDE GATE ADJUSTMENT.....	40
REPLACEMENT PARTS LIST / WARRANTY/ SERVICE RECORD.....	41-44
WARRANTY REGISTRATION CARD.....(IN HARDWARE PACKET)	

CLEAN BURN CORN ADDITIVE TM

AMERICAN ENERGY SYSTEMS INC. HAS DEVELOPED AN ADDITIVE THAT WHEN MIXED WITH CORN VIRTUALLY ELIMINATES THE (CLINKERING) THAT IS CAUSED BY THE COMBUSTION PROCESS OF BURNING CORN.

HOW DOES IT WORK AND WHY DO YOU NEED IT?

The clean burn additive is a unique blend of the right ingredients that will oxygenate the combustion process producing a cleaner more productive fire. This will generate more BTU'S out of corn, clean up the combustion process and produce less ash.

HOW DO YOU MIX THE CLEAN BURN ADDITIVE?

Depending on how much starch or protein content that you have in your corn supply you will have to change the percentage of mixture. The normal mixture is a ratio of one (1) part Clean Burn additive to 150 parts of corn. This translates to approximately 1/2 pound of Clean Burn for every hopper of corn. (app. 1-2 handfuls)

To mix the Clean Burn additive simply add it to the corn and mix in by hand.

If you have corn with low starch content you may be able to decrease the mixture, and corn with high starch content will require more. The easiest way to tell if the mixture is right is, after a day of burning, look at the Fuel Stirrer in the Firepot and if there is any buildup of clinker on the fingers you need to increase the mixture.

If there is excessive white powder in the firepot you can decrease the mixture.

Using the Clean Burn additive will reduce maintenance, ash content, buildup in the firepot, fly-ash on the outside of the home and will increase the heat output. The additional heat output will more than pay for the cost of the additive.

CAN I USE OYSTER SHELLS/CRUSHED EGG SHELLS AS AN ADDITIVE?

We have found that the oyster shells/ crushed egg shells, even though they will work, can cause auger jams, pre-mature wear or damage to the auger motor and excessive ash buildup if not used properly. We recommend that you use oyster shells/crushed egg shells sparingly (1 handful per hopper est.) and vacuum the hopper out once a week. If you do use them excessively it will cause the auger system to fail. The auger system is not warranted against wear or damaged caused by abrasion or jamming.

GIVE CLEAN BURN A TRY. YOU WILL BE PLEASANTLY SURPRISED.

DEAR VALUED COUNTRYSIDE OWNER,

We appreciate your decision to help preserve our precious environment by purchasing the **Magnum Countryside Biomass Corn/Wood Pellet Appliance**. With everyone working together, we can have clean air and renewable heat for our homes.

Please read this Owners Manual carefully before using this appliance and if you have any questions contact your local **Magnum** reseller. We appreciate your business and wish you many warm days and nights with your new **Magnum Countryside Biomass Corn/Wood Pellet Appliance**.

Sincerely,

Mike

Mike Haefner, President
American Energy Systems, Inc.

P.S. You are very important to the success of our business and your referral of our products is very much appreciated. Many of our Resellers have referral rewards available and I encourage you to ask your local dealer how to get involved in helping make our country energy self-sufficient. **GOOD LUCK!**

SPECIFICATIONS

American Energy Systems, Inc., manufacturer of the **Magnum Countryside Biomass Corn/Wood Pellet Appliances**, reserves the right to alter its products, their specifications and/or price without notice.

Safety tested and EPA exemption tested by Omni-Test Laboratories, Inc to UL 1482, CAN/ULC-S627, ULC-S628, APFI requirements, Oregon administrative rules 814-23-900 to 814-23-909 and E.P.A. Method 28A.

	3502 Insert	3500P&3500L
Heat Range*	10,000 to 56,000 BTU/HR	
Fuel Storage Capacity	Up to 75 Lbs.	Up to 75 Lbs.
Width	28"	28"
Height (Insert)	23"	N/A
Height with Pedestal	N/A	33"
Depth	28"	28"

	CLEARANCE TO COMBUSTIBLES	
	Vertical Termination w/ 3" Pellet Vent	Horizontal Termination w/ 3" or 4" Pellet Vent
Back	1"	9"
Side	1"	1"
Corner	1"	1"

BTU output will vary, depending on the brand of fuel, size of fuel, quality of fuel and moisture content.

Consult your authorized Magnum dealer for information on the best fuel to use to get the best results.

Fuel feed rates can vary as much as 50 percent depending on fuel quality, size, brand and moisture content

Importance of adequate fresh Combustion Air

Every home is a slightly different situation and depending on the design of the air movement within the home, might be easy to distribute heat or very difficult. If you have boiler heat or other non-ducted central heating this becomes even more of a challenge as adequate circulation within the home and proper make up air for combustion is lacking because of the design of your central heating system.

When a forced-air system is put into a home that is not designed with proper circulatory patterns, it might be necessary to add return air ducts or at least vents to get the air moving around the home. Fresh air for the home and fresh air for combustion will have to be added or the stove or furnace will burn dirty and efficiency will suffer.

Your dealer needs to assess the fresh air requirements for the home. At a minimum, there should be a 6" or larger (this should be determined by figuring what the home requires) fresh air vent coming in to a neutral part of the home to make sure that there is adequate fresh air to the home. Then the 3" make up air to the unit is required to be provided. **This must be done on every installation.**

If the (fuel) corn is not burning correctly you need to address a few things. Is the corn wet or dirty? If it is, make sure that your corn is cleaned and below 15 percent moisture. 11-12 percent moisture is ideal. Also make sure that your appliance is installed, venting and operating properly.

The most common cause of corn not burning properly is contaminated air or negative pressure in the home. It can be as simple as the air adjustment not set properly on the side of the stove or it could be that there is a serious lacking of good quality air in the home caused by negative pressure. If you have done any remodeling or if this is a newer home, it is a very real possibility that this is happening. Most basements have negative pressure even if you feel that your home is drafty. This is called the stack or chimney effect. **This is the number one cause of a unit not performing properly.**

If there is a black coating of soot coming into the home it is caused by the reversal of the exhaust that would normally exit the stove outside being drawn into the home by negative pressure or improperly installed venting. Depending on your venting configuration this could be aggravated by back drafts, high wind and cold chimneys. **This is a serious issue. Consult your dealer or installer immediately.**

Sometimes this also occurs if there is an intake for fresh air too close to the exhaust on the outside of the home or other conditions causing the exhaust to be pulled back into the home.

The first indications of negative pressure affecting the stove occurs app. 3 days after the stove is lit. The glass gets dirty very easy, the firepot might keep filling up even though you pull the air adjustment out, and you notice that the venting fills up with soot rapidly. After a few days, the exhaust can no longer adequately pull out all of the fly ash so it reverses and is pulled into the home. This might happen through the venting if it is not sealed properly or it might come out when you open the door for maintenance and also backwards through the air wash system.

This can be easily corrected by adding the fresh air for the home and also for the appliance. It is imperative that you would have your dealer or installer check the unit out for proper operation to make sure that there is nothing mechanical wrong with the appliance and then determine your need for proper fresh air. Your dealer can contact the factory with any questions that he might have.

SAFETY STEPS

IMPORTANT: Proper installation of this stove is crucial for proper and safe operation. Installing this product improperly may result in a house fire and personal injury. All applicable building codes for your location must be followed. In areas where building codes require additional steps to the installation of this product not included in this manual, the building codes will take precedent and must be followed. Contact your local building inspector to obtain any necessary permits or inspection guidelines before installing the product. **(This appliance should be installed by a trained professional installer to assure proper installation and warranty of this product) Warranty Labor and shipping will not be covered if the unit is not installed according to the instructions included in this manual.**

- ✓ **DISCONNECT THE POWER CORD BEFORE SERVICING THIS STOVE! A power surge protector is required.** The unit must be plugged in to a **grounded** 110 -volt power source.
- ✓ Always route the power cord away from the unit. Do not route cord in foot traffic areas. Do not pinch cord under furniture. Do not add any additional length to the power cord.
- ✓ This product requires simple periodic maintenance for proper operation and long life of the stove. Read and follow the maintenance schedule closely.
- ✓ **The Magnum Countryside stove is designed, approved and tested to burn shelled corn, or wood pellets.** Other fuels may require purchasing a different firepot or other accessories. The burning of other solid fuels such as cord wood in this stove is not permitted. If you are burning fuels not approved for this appliance it will void the warranty and no service/warranty will be allowed. The Magnum Countryside will burn high ash content fuels but will require additional maintenance/cleaning.
- ✓ A working smoke detector must be installed in the same room as this product.
- ✓ Flammable or explosive liquids such as gasoline, naphtha or engine oil must NEVER be used in or around this stove. These liquids must be stored well away from this stove as the open flame in the burner chamber could ignite the fumes of such liquids. **Do not burn garbage in this unit.**
- ✓ According to HUD requirements, when installed in a mobile home, this stove must be grounded directly to the steel chassis of the mobile home and bolted to the floor.
- ✓ This stove is not intended for use in commercial installations but can be used.
- ✓ The moving parts of this stove are propelled by high torque electric motors. The auger and Fuel Stirrer can cause severe injury to body parts that may get near them. Keep all body parts away from the auger and Fuel Stirrer while the stove is plugged into an electrical outlet. These moving parts may begin moving at any time while the stove is plugged in.
- ✓ This unit must be installed on a non-combustible surface. Make sure that the unit is level.
- ✓ Do not attempt internal service to the unit when it is burning and or plugged into power.
- ✓ It is a good idea to burn the unit outside for a couple hours before installation to burn off any paint or oil fumes. (most resellers pre-burn the unit before you receive them, do not worry if your unit has looks like it has been burnt)

IMPORTANT: It is the customer's responsibility to make sure the Magnum Countryside appliance is installed with the proper make up air system and the home is checked for adequate fresh air so that the appliance does not become the fresh air source for the home.

BURNING SOLID FUELS (shelled corn and wood pellets)

Unlike petroleum and natural gas products, solid fuels such as corn and wood pellets create ash as the fuel is burned. Even with the highly efficient flame your **MagnuM Countryside** stove will produce, the solid fuels used will produce ash. This ash will have to be cleaned out of the stove from time to time. The cleaning procedure will be discussed later in this manual. You can minimize the amount of cleaning required and maximize the efficiency of your stove by maintaining the correct draft settings.

The draft setting on your stove may have to be changed from time to time to accommodate your specific burning conditions. Proper draft setting will be discussed later in this manual. The point we wish to make here is that your **MagnuM Countryside** stove, due to the nature of solid fuels, will require brief periodic attention. Please do not expect to light your stove and walk away from it until you want to shut it off in the spring. A few moments of adjustment and cleaning from time to time are an important part of burning solid fuels.

The **MagnuM Countryside** stove has been designed to burn shelled corn or wood pellets that meet the Association of Pellet Fuel Industries standards. Since both of these fuels vary greatly in quality and consistency, AES cannot be responsible for damage done to your stove due to fuel problems. The following are guidelines to using and selecting proper fuels for your stove.

SHELLED CORN (11-12 percent moisture recommended)

- ✓ Store your corn supply in a dry place and keep the bags or container sealed to prevent your corn from absorbing excess moisture. Test the moisture content periodically to maintain the proper dryness. **Check your Corn for foreign objects. Your stove warranty will not cover damage done to your stove due to foreign objects in the fuel supply.**
- ✓ **Do not carry your corn supply over into the next heating season if possible unless properly stored.** If you carry over your corn supply make sure to check the corn for proper moisture content.
- ✓ **DO NOT BURN “TREATED” SEED CORN IN YOUR STOVE.** Seed corn is treated with chemical pesticides that are harmful or fatal if swallowed; therefore, seed corn is dangerous to have in the house, especially where children can reach it. **Burning treated seed corn in your stove will void the warranty and will destroy the exhaust system on the unit.**
- ✓ **Corn must be 14% or less moisture content.** Wet corn will cause rapid plugging and deterioration of the stove and exhaust system, lower the heat output and will void the product warranty.
- ✓ Corn must be cleaned and free from debris. Corn right from the field will often have stalks, sticks, bolts and cob debris, which can plug the auger and/or cause damage to the auger and motor. Damage caused by dirty corn and other foreign objects are not covered by the product warranty. Ask for clean corn when you purchase it from your local corn supplier. Clean corn can be purchased in bulk or bagged from most elevators, feed stores or even your local farmer.

ALWAYS ASK FOR CORN WITH 11-12% MOISTURE CONTENT.

If you are having trouble finding clean corn, contact your local MagnuM Countryside Dealer and ask them to get you information about corn cleaning system. Cleaning your corn with the Energy Sifter from American Energy Systems will assure clean corn and a more consistent burn rate. It is also important to vacuum out your hopper once a month to assure trouble free auguring of the corn.

- ✓ There are many varieties of corn grown around the world. Each variety has unique characteristics including the shape and size of the kernel. Your stove will burn more consistently with a small to mid-size kernel corn. If the kernel size of the corn varies greatly or if you switch sources frequently, you will get a less consistent burn, which will require more attention to the draft setting on your stove. Therefore, purchasing corn from the same source will help achieve a more consistent burn. **DO NOT USE CORN WITH A HIGH WAX CONTENT!**

WOOD PELLETS

- ✓ As with corn, be consistent in your pellet supplier. Pellets will vary in content and burn characteristics from supplier to supplier. A consistent supply of pellets will require fewer adjustments to the draft of the stove.
- ✓ Check your pellets for foreign objects. Your stove warranty will not cover damage done to your stove due to foreign objects in the fuel supply. **Vacuum the hopper to get rid of sawdust.**
- ✓ Store your pellets in a dry place to prevent them from absorbing excess moisture.
- ✓ **Vacuum the hopper out after every 6-7 bags to eliminate buildup of sawdust.** More often if the pellets are poor quality. If sawdust is a problem you will have to screen each bag of fuel for a consistent feed.
- ✓ Wood pellets vary from supplier to supplier in ash content from less than 1% to 3% or more. Low ash content pellets will allow you to burn the stove longer between cleanings. Only wood pellets manufactured to the Association of Pellet Fuel Industries (A.P.F.I.) standard for residential pellet fuels are recommended. Look for A.P.F.I. registration number on the back of pellets. Consult your local **Magnum Countryside** dealer for more information on approved wood pellet fuel.

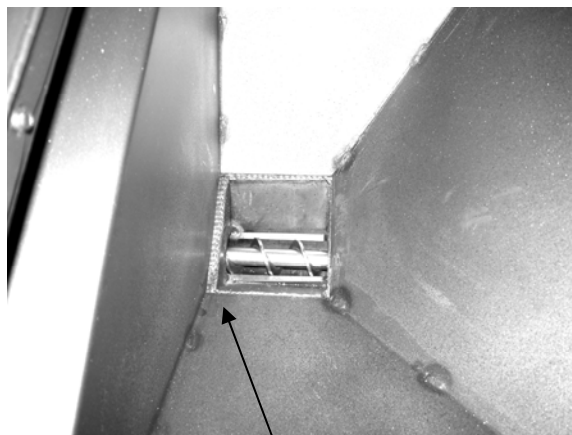

Inside of hopper

UNPACKING YOUR MAGNUM COUNTRYSIDE CORN/PELLET STOVE

When you receive your **Magnum Countryside Corn/Pellet Stove, Leg unit or Fireplace Insert**, be careful to inspect all parts and components to make sure that nothing was damaged or lost in shipment. If there was shipping damage, be sure to report it to your Countryside reseller, or the shipping company that delivered your unit. **Freight damage claims must be made to the Freight Company immediately.** If parts are missing contact your local **Magnum Countryside** dealer or contact the factory right away. **Your satisfaction is our top priority.**

To uncrate you're **MagnuM Countryside Corn/Pellet Stove:**

- 1) Cut the banding straps and open the carton lid. The carton is stapled to the wood pallet so it will be necessary to pull the cardboard loose from the pallet. Remove the crating box carefully lifting up over the top of the unit. Be careful not to scratch the unit with the staples. Remove the wood blocks and plastic. We strongly urge you to recycle the packaging materials to help protect the environment.

The Pedestal Ash Pan unit comes completely assembled, the Insert comes with the shroud packaged separately and the Leg unit comes with the Legs packaged in the hopper.

The installation of the Insert Shroud is shown later in the installation manual. Make sure that the shroud is with the unit when you get it.

The following diagram will show how to install the legs on the Leg Unit. The legs are wrapped up and packaged in the hopper. Unpackage the legs and get the (4) nuts out of the hardware bag.

Tip the unit back so that you can get the leg onto the bolt that is sticking down in each corner of the bottom of the base. Be sure to have someone helping hold the unit while you are attaching the leg. The casting could break if bound or dropped. **NOTE: It is best to attach the legs on one side first and then lift the unit up level to attach the other side. You can also attach the legs on the back two corners first and then the front.**

Place the ¼" nut on the bolt that is located on the base of the unit and attach the leg to the bolt. Swing the leg so that the foot of the leg is parallel with the 45-deg. angle of the front of the unit. Align the back leg to match the front leg.

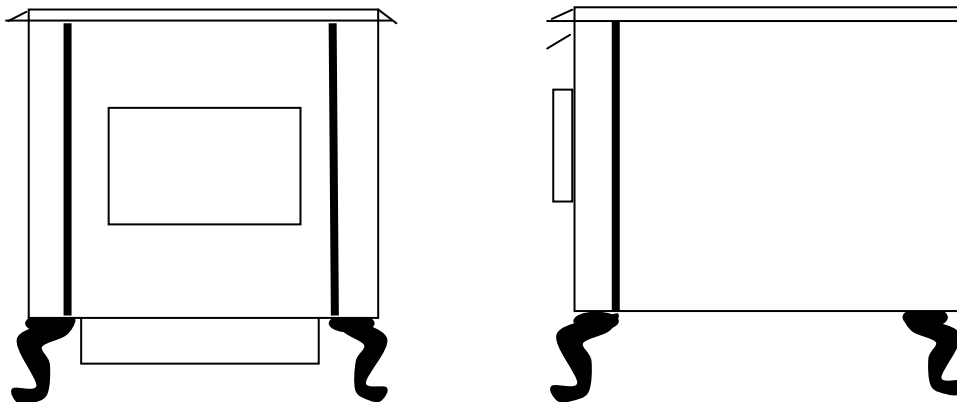

Be careful not to bind the leg when bolting onto the unit so that it does not break. The legs are designed to face at a 45 degree angle so that they will face in the same direction as the slanted side of the face.

When the legs are bolted on and positioned where you like them, tighten the (4) four nuts. Make sure not to over tighten the nuts and twist them off.

FLOOR PROTECTION

The **MagnuM Countryside Freestanding Stove** may be installed on a combustible floor, with proper floor protection, or on a masonry hearth. The hearth or non-combustible floor protector must extend a minimum of (6) six inches in front of and (8) eight inches from each side of the ash removal door.

NOTE: If installing the 3502 (Insert Model) into a build-in application where there is not an existing fireplace, you will have to install a non-combustible floor underneath and 6 inches out in front of the unit. This would require a 2-3 inches thick masonry floor (the thickness of one brick) or ¾ inch thick rock board.

CLEARANCES TO COMBUSTIBLES

The stove must be installed with the following minimum clearances to side and back wall combustible materials. **NOTE:** These are minimum clearances to combustible walls established by the testing lab. The amount of room needed on the left side of the unit to access the electrical panel is (6) six inches. When venting straight out the back of the unit, the B clearance is 1". C clearance is for a vertical vent install.

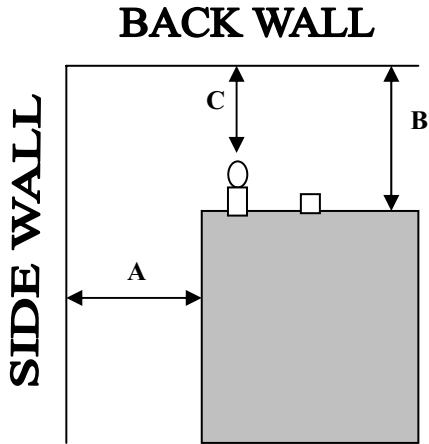

**Residential/ Mobile Home
Vertical Installation**

A=1" B=7" or 1"
if straight out the
wall install
C=3" if tee install
D=3" E=1"

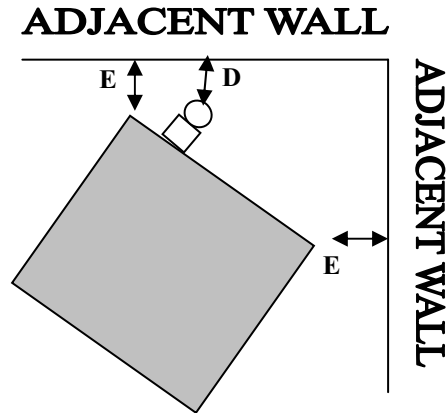

**Residential/Mobile Home
Horizontal + Vertical
Corner Installation**

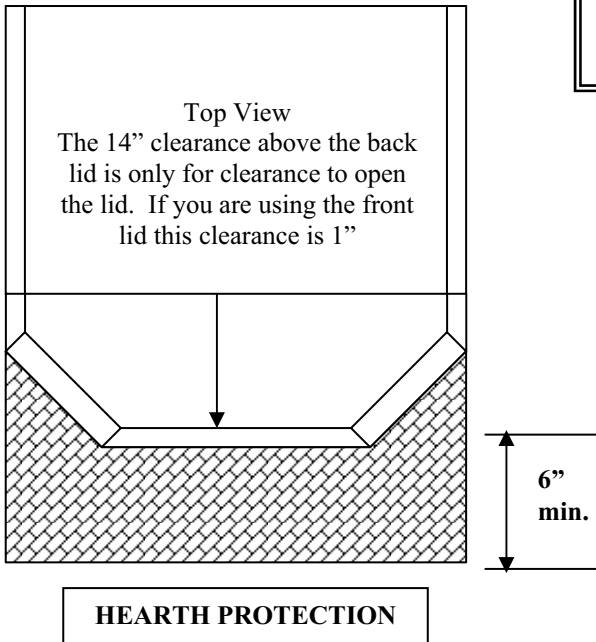

The side and top clearance are to be used when installing the CountrySide into an alcove as shown to the left and below.

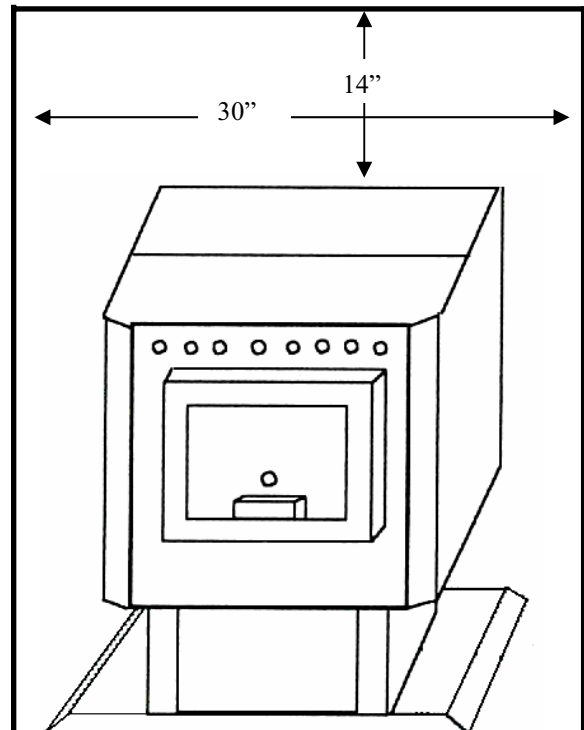

GUIDELINES FOR EXHAUST VENTING SYSTEMS DESIGN

It is recommended that only an authorized Magnum Countryside installer install your pellet/corn stove. The following installation guidelines must be followed to ensure conformity with both the safety listing of this stove and to local building codes.

- ✓ A listed 3” or 4” type “PL” pellet vent exhaust system must be used for FREESTANDING installation and attached to the pipe connector provided on the back of the stove. Use a 3” to 4” adapter for 4” pipe. A cap must be used at the termination of type “L” vent chimneys. When in doubt about what size to use, use 4” venting.
- ✓ Do not terminate vent in any **enclosed or semi-enclosed** area, such as; carports, garage, attic, crawl space, under a sundeck or porch, narrow walkway or closed area, or any location that can build up a concentration of fumes such as a stairwell, covered breezeway, etc.
- ✓ Vent surfaces can get hot enough to cause burns if touched by children. Non-combustible shielding or guards may be required. **Do not install a flue damper in the exhaust vent of this unit.**
- ✓ Termination must exhaust at least 2 feet above air inlet elevation. **It is recommended that at least 5 ft. of vertical pipe be installed when the appliance is vented directly through a wall or in a basement.** This will create some natural draft to prevent the possibility of smoke or odor during appliance shutdown and to keep exhaust from causing a nuisance or hazard from exposing people or shrubs to high temperatures. In any case, the safest and preferred venting method is to extend the vent through the roof. **Do not connect this unit to a chimney flue serving another appliance.**
- ✓ Distance from doors and windows, gravity or ventilation air inlet into building:
Not less than 4 ft. / 1.2 m below, 4 ft. / 1.2 m horizontally from, 1 ft. / 305 mm above (This does not apply if the Windows are non-opening or have been fixed so they cannot open.)
- ✓ Distance from bottom of termination and grade – 1 ft. / 305 mm minimum. This is conditional upon the plants and nature of grade surface. We recommend at least 2 feet / 610mm. The exhaust gases are not hot enough to ignite grass, plants or shrubs located in the vicinity of the termination. The grade surface must not be a lawn. Distance from bottom of termination and public walkway is 7ft. / 2.1m minimum.
- ✓ Distance to combustible materials – 2 ft. / 610 mm. This includes adjacent building, fences, protruding parts of the structure, roof overhang plants and shrubs, etc.
- ✓ It is recommended that a single or double clean-out “tee”, for cleaning the vent in both directions, be installed at every 90° junction to enable collection of fly ash and to permit periodic cleaning of the exhaust system. 90° elbows accumulate fly-ash and soot thereby reducing exhaust flow and performance of the stove.
- ✓ Total equivalent length of horizontal vent must not exceed (10 ft.) / 3 m. **We recommend not going over 5 feet and will need to be done if the unit does not operate correctly.** Extra cleaning will have to be done over 4 feet. All joints in the vent system must be fastened by at least 3 screws, and all joints must be sealed with RTV silicone sealer to be airtight.
- ✓ A 3” single-wall, stainless steel flexible or rigid exhaust pipe should be used for INSERT installations and must be attached to the stove with a single-wall, stainless steel “tee” with a clean-out cap. The stainless steel “tee” should be inclined at 45° to enable the vent to be centered on the stove and allow the “tee” to be cleaned without removing the stove (see diagram on page 17).
- ✓ When venting into an existing masonry or factory built chimney, the chimney must be cleaned, with all creosote removed. The chimney must be a type suited for solid fuel. **WARNING:** The chimney and the chimney connections must be kept clean and in good condition.
- ✓ The “PL” vents or single wall stainless exhaust system must be installed so as to be GAS TIGHT! The vent manufacturer’s installation procedures must be followed. In addition, pipe connections, joints and all pipe seams within the home should be sealed with high temperature RTV silicone sealer.
- ✓ If an insert is to be installed into an unlined masonry chimney, it is recommended that at 3” or 4” stainless steel pipe be extended to the top of the existing chimney. The top of the existing chimney should be sealed with a steel plate (see diagram on page 17).

GUIDELINES FOR EXHAUST VENTING SYSTEMS DESIGN, CONT.....

To determine whether a 3” or 4” exhaust system should be used, follow the guidelines below:

- 1) Determine the “equivalent pipe length” for each component used according to the comparison chart below. Add the “equivalent pipe length” of all components to get the “total equivalent pipe length”.
- 2) Determine the altitude at which you are installing the stove.
- 3) Cross-reference the “total equivalent pipe length” and the altitude using the graph below.

NOTE: The “total equivalent pipe length” should not exceed 30 feet.

Component	Equivalent Length	Equivalent Pipe Length			
			=		
Horizontal Straight Pipe	Actual Length in ft. x 1.0	Horizontal Pipe	=	1 x (2+1) =	3 ft.
Vertical Straight Pipe	Actual Length in ft. x 0.5	Vertical Pipe	=	0.5 x 8 =	4 ft.
90° Elbow or Tee	5.0 feet	90 Degree Tee	=	2 x 5 =	10 ft.
45° Elbow	3.0 feet	45 Degree Tee	=	1 x 3 =	3 ft.
		TOTAL	=		20 ft.

NOTE: These are guidelines only. Proper venting is accomplished by design and common sense. In most installations 3 inch diameter venting is adequate. If it does not vent properly you will have to change it to 4”. When in doubt about what size to use, then use 4 inch. Insert installations should use 4 inch.

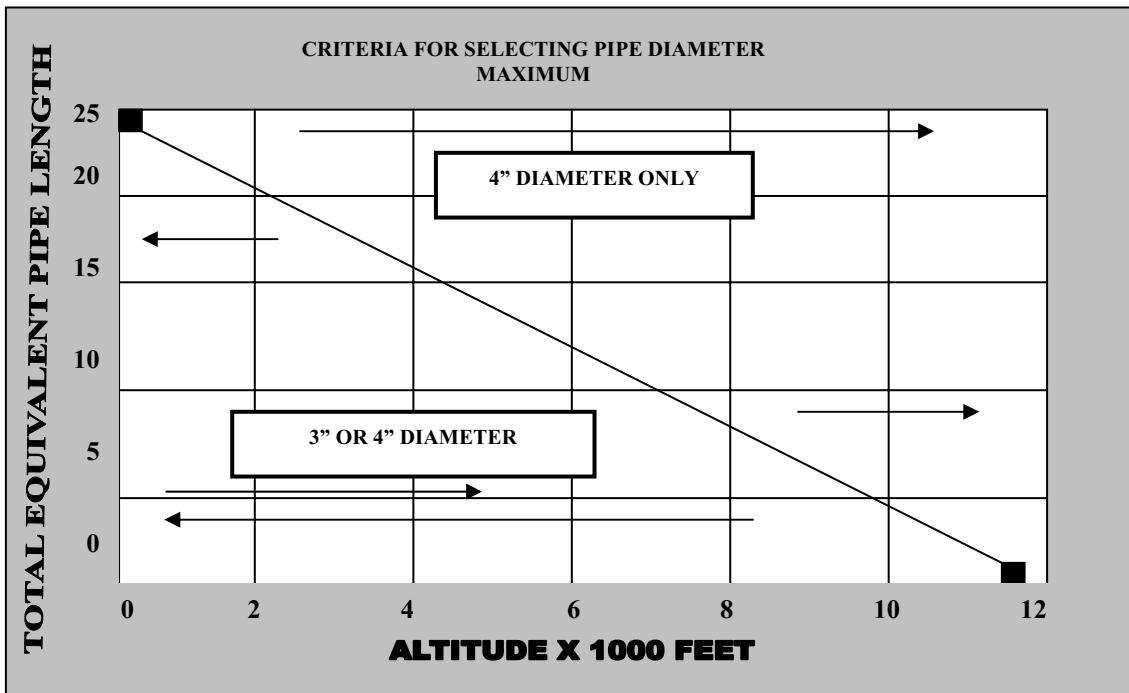

DESIGN GUIDELINES FOR OUTSIDE COMBUSTION AIR CONNECTION

OUTSIDE MAKE-UP AIR FOR COMBUSTION IS REQUIRED ON ALL INSTALLATIONS

- 1) For FREESTANDING installations with horizontal through-the-wall exhaust, it is REQUIRED that the stove combustion air intake be connected to a fresh air intake outside. If the home is newer or has been tightly insulated it is imperative to the operation of the unit to install outside combustion air. If you do not, then an additional 6 inch intake into the furnace room in the basement is required.
- 2) For INSERT installations into an existing fireplace, or FREESTANDING installations with a vertical exhaust, outside air connection is required.
- 3) Connection to outside the house is REQUIRED for mobile home installations.

IMPORTANT: It is the customer's responsibility to make sure that there is adequate fresh air to the home so that the Magnum Countryside appliance does not become the fresh air source.

90 DEGREE BEND TERMINATION

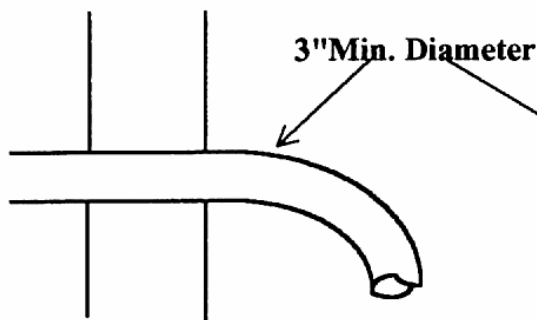

WIND HOOD TERMINATION

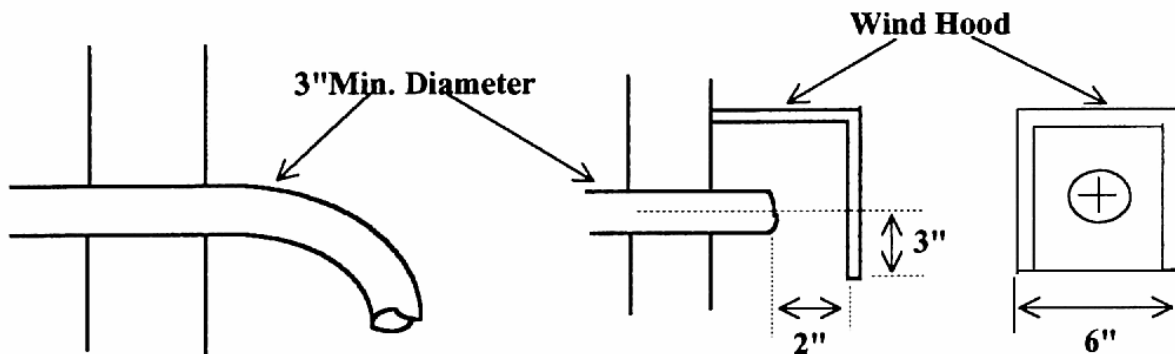

- 4) Only non-combustible pipe 3 inches in diameter is approved to use for outside air connections (straight or flexible). PVC pipe is NOT approved and should NEVER be used.
- 5) If the air inlet is connected to the outside, it MUST be terminated with a vertical 90-degree bend (down) or with a wind hood. Failure to do so could result in a burn back during high winds blowing directly up the air inlet during a simultaneous power failure (see diagram above).
- 6) It is important not to terminate the inlet of the fresh air intake too close to the venting outlet for the smoke. It is recommended that the inlet for the fresh air is a minimum of 3 feet away from the venting outlet and at least 2 feet below.
- 7) Blockage, excessive length, or bends in the air intake pipe will starve the stove of combustion air. A 90-degree bend is equivalent in restriction to approximately 30 inches of straight inlet pipe.

INSTALLATION PRECAUTIONS

CAUTION: Do not install this appliance in any manner other than as described in this manual. If you have any questions about properly venting or installing your **Magnum Countryside Biomass Corn/Wood Pellet** stove, please contact your dealer or American Energy Systems, Inc. for information.

NOTE: THIS STOVE MUST BE BURN TESTED OUTSIDE IN A WELL VENTILATED AREA FOR AT LEAST (4) FOUR HOURS. THIS WILL CURE THE PAINT AND SEASON THE STOVE METAL. SMOKING AND STEAMING IS NORMAL DURING THE CURING PROCESS, AND MAY CONTINUE DURING THE FIRST FEW TIMES THE STOVE IS USED.

The **ONLY** authorized exhaust vent pipe for this appliance is **3 or 4 inch listed Type PL pellet vent pipe**, designed for use with corn or pellet stoves. This stove may be connected to an existing factory-built chimney using pellet vent pipe as a connector, and a 3-4", 3-6", or 3-8" **PELLET VENT to CHIMNEY ADAPTER**. Follow the pellet vent pipe manufacture's instructions for the installation of the vent pipe being used. (See "Existing Vertical Installation").

As you plan your installation, consider the following:

- The stove should be placed as central in the home as possible. Consider safety, convenience, traffic flow and the fact that the stove will need a venting system and fresh air to the outside of the home.
- Before drilling or cutting holes, select the location of the appliance. Determine where the ceiling rafters, wall studs or floor joists are located before making any large holes as the appliance may have to be moved.
- Care must be taken to maintain minimum clearances to combustibles as per local building codes, fire codes, and the safety listing tag on the inside hopper lid.
- An outside air source **must be** connected to the stove and can be brought in through the sidewall or vented crawl space. Flexible or rigid pipe should be used and will connect to the adaptor on the back of the stove. (See air inlet location under the **CLEARANCE** section of this manual)
- Place the stove where you will enjoy watching the fire along with getting the best heat distribution possible. Locating the stove in a closed room will not allow the unit to perform properly. Installing the stove in an un-insulated area will also not allow the stove to heat the home properly.
- If the home was not designed with proper heat circulation, the stove will not perform properly. Make sure that the installer looks at the entire home as a unit when installing your Countryside appliance. Make sure that there is adequate cold air returns to pull the heat to adjoining rooms.

**DO NOT CONNECT THIS STOVE TO A CHIMNEY FLUE SERVING ANOTHER APPIANCE.
DO NOT USE SINGLE WALL PIPE FOR ANY INSTALLATION.
DO NOT INSTALL A FLUE DAMPER IN THE EXHAUST VENTING SYSTEM OF THIS UNIT.
THIS EXHAUST SYSTEM IS PRESSURIZED.**

Electrical power is 115volt-60 Hz. The stove is provided with a six foot grounded electrical cord, and should be connected to a standard 3 prong 115volt, 60 Hz electrical outlet. (Make sure you have a surge protector) Do not route the cord in front of, or under the stove.

NOTE: A MAJOR CAUSE OF VENT RELATED FIRES IS FAILURE TO MAINTAIN REQUIRED CLEARANCES (AIR SPACES) TO COMBUSTIBLE MATERIAL. PLEASE FOLLOW THE VENT PIPE MANUFACTURERS INSTRUCTIONS AND LOCAL BUILDING CODES FOR THE PROPER CLEARANCES TO COMBUSTIBLES REQUIRED FOR THE INSTALLATION OF THE VENT PIPE BEING USED.

VENT TERMINATION GENERAL INSTRUCTIONS

NOTE: The following are general instructions for installing this appliance.

THE VENT PIPE MANUFACTURER'S INSTRUCTIONS SHOULD BE FOLLOWED FOR THE VENT PIPE BEING USED. USE ONLY 3 or 4 INCH LISTED TYPE PL PELLET VENT PIPE.

WARNING: Shut off all electrical power to the wall or room where the appliance is going to be installed before cutting any holes. Be careful not to drill or cut into any water lines or electrical wiring as water damage or electrical fire may result.

Upon determining the best location for your new appliance, maintain at least the minimum allowable clearances. Line up a plumb bob to the flue collar on the stove with the location for the hole in the wall or ceiling before drilling or cutting any holes. (See rear exhaust and air inlet locations under the **CLEARANCE** section of this manual) **Be sure to allow for any stove pad that you will be placing underneath the unit.**

Prepare the vent pipe for painting (if you are painting the venting) by wiping down with straight vinegar. Rinse vinegar off with clean water and allow the pipe to dry. Use high temperature paint as directed by the manufacturer (the standard paint is Stove Bright Metallic Black). Let the paint dry for a couple hours before assembling.

Drill and enlarge the hole as required for installation of the wall thimble, vent pipe and components **per the pipe manufacturer's instructions.**

Connect the pipe and lock the joints as directed by the pipe manufacturer, and secure the vent pipe to the flue collar on the back of the stove. Add a small bead of RTV high temperature silicone around the outside edge of the flue collar prior to securing the vent pipe. Drill and attach the vent pipe to the flue collar with sheet metal screws. **Alternate (preferred) method:** Attach the approved PL pipe adaptor on the back of the exhaust pipe located on the rear of the appliance, secure with a 3" hose clamp and then attach all venting to the pipe adaptor.

Do not terminate the vent in any enclosed or semi-enclosed area, such as a carport, garage, attic, crawl space, under a sun deck or porch, in a narrow walkway or closely fenced area, stairway, covered breezeway, or any other location which can build up a concentration of flue gases.

Vent surfaces can become hot enough to cause burns if touched. Non-combustible shielding or guards may be required.

Note: make sure that you leave adequate clearance between the back of the unit and the wall to allow for proper cleaning, service and also so that when you open the hopper lid that it does not hit the wall. It is recommended that you leave 4-6 inches of clearance between the appliance and the back wall of the home.

NOTE: THE VENT PIPE SHOULD BE INSPECTED FREQUENTLY TO VERIFY THE INTEGRITY OF THE VENTING SYSTEM AND TO INSURE THAT NO OBSTRUCTIONS OR BUILD-UP EXIST WITHIN THE VENT PIPE. FAILURE TO INSPECT THE VENT PIPE CAN CAUSE A MALFUNCTION OR HAZARDOUS OPERATION OF THE STOVE.

INSTALLATION CONFIGURATIONS

The Magnum Countryside Biomass Corn/Pellet Stove / Fireplace Insert may be installed as follows:

- 1) A freestanding unit 3500P & 3500L models
- 2) A hearth mounted fireplace insert into a masonry or factory built fireplace (3502 & 3500L)
- 3) A built-in heater mounted in an alcove with a pedestal (3500P & 3500L)
- 4) A built-in heater mounted on a non-combustible floor without a pedestal (3502 & 3500L)

MOBILE HOME INSTALLATION REQUIREMENTS

IN ADDITION TO THE STANDARD INSTALLATION INSTRUCTION, THE FOLLOWING REQUIREMENTS ARE MANDATORY FOR INSTALLATION IN A MOBILE HOME:

WARNING
DO NOT INSTALL IN SLEEPING ROOM

- 1) Stove must be permanently bolted to the floor.
- 2) Stove must have permanent outside air source.
- 3) Stove must be permanently electrically ground to the steel chassis of the mobile home.
- 4) All vertical chimney vent must have wall supports every (5) five feet.
- 5) All exhaust systems must have a spark arrestor.

CAUTION
The structural integrity of the mobile home floor, wall and ceiling must be maintained.
Check with your local building official as other codes may apply.

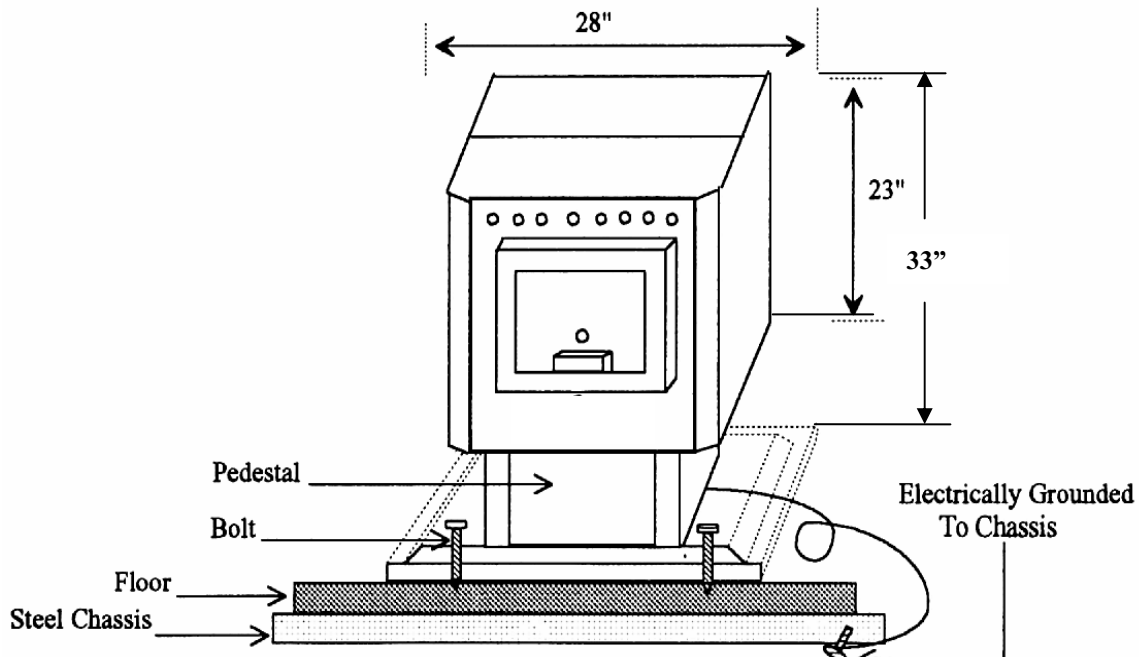

ALCOVE INSTALLATION REQUIREMENTS

The **MagnuM Countryside** is approved for the standard alcove height of 72 inches, or for a reduced alcove height with a minimum of 14 inches from the top of the stove (clearance for opening top lids). The maximum alcove depth is 60 inches and the listed side clearances are a minimum of 1 inch. The 14" clearance is only needed for opening the back lid. If the front lid protrudes out of the opening a 1" clearance is all that is required.

ALCOVE CLEARANCE RECOMMENDATIONS

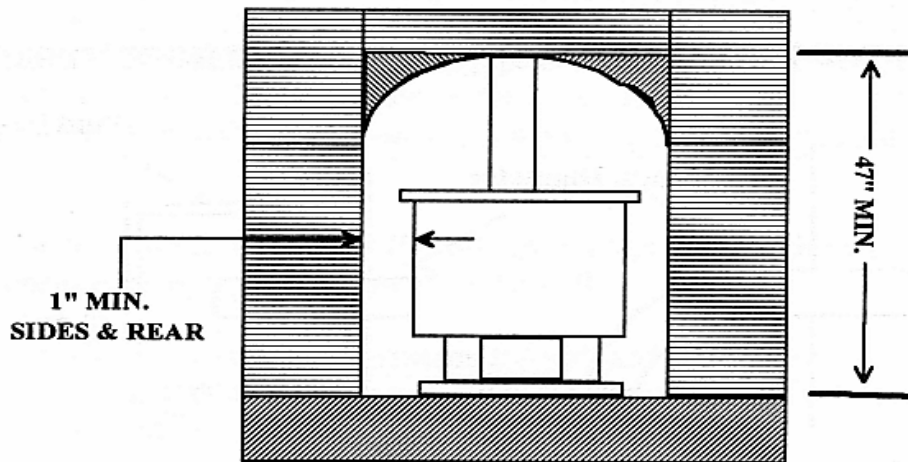

ALCOVE - THROUGH THE WALL INSTALLATION REQUIREMENTS

The stove is approved for horizontal exhaust; however, we recommend that the exhaust goes vertically for five feet, or above the eave of the house. This will help draw smoke out of the stove in the event of a power failure.

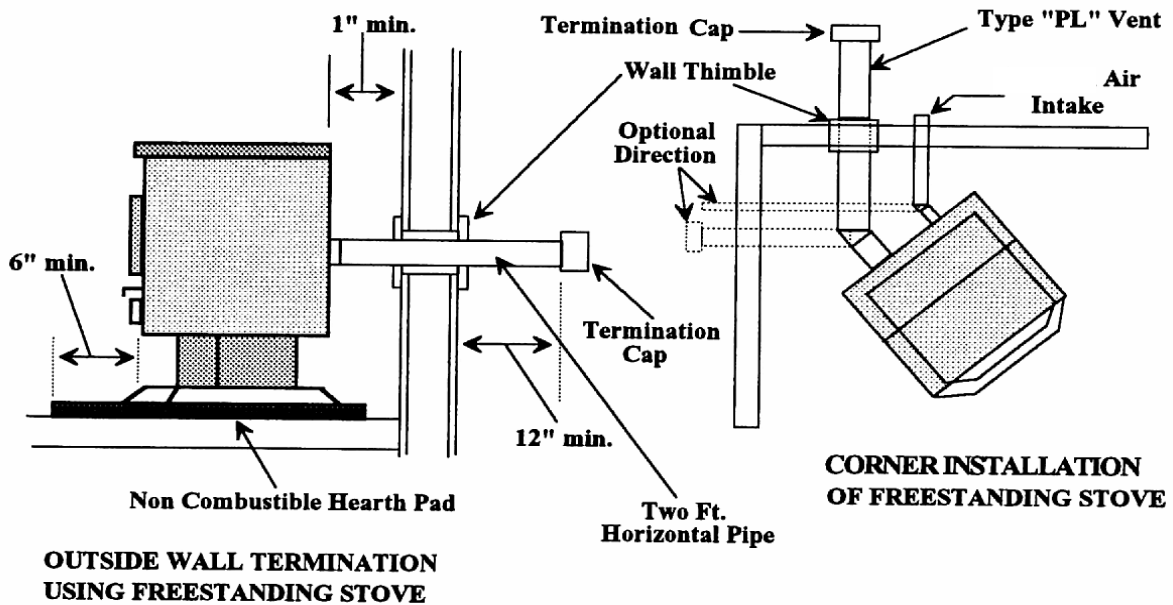

FREESTANDING STOVE INSTALLATION REQUIREMENTS

Horizontal Exhaust Termination:

- 1) Locate proper position for the type "PL" wall thimble (F). Use a saber saw or key-hole saw to cut a
- 2) 7 1/4-inch diameter hole through the wall (G) for a 3-inch pipe. For a 4-inch pipe, cut an 8 1/4-inch hole. Install the wall thimble in the hole. The size of hole opening will vary with brand of wall thimble.
- 3) Position stove approximately 12" from the wall on the noncombustible floor pad. Push the type "PL" pipe (D) through the wall thimble (F). Squeeze a bead of high temperature RTV silicone sealer (A) around the outside of the 3" diameter exhaust pipe approximately 1/2" from the stove back panel (B). Firmly push on a section of type "PL" pipe (D) until the inner pipe liner pushes up against the bead of RTV sealer. Don't seal the entire 3" diameter pipe as you will not be able to disassemble the pipe at a later date. The bead of silicone will act as a gasket right on the end of the 3" pipe (D). **Alternate Method:** An approved type "PL" connector back clamp may be used to allow easy disconnect for maintenance. (The RTV sealant must be used in mobile home installation)
- 4) Push stove with pipe attached towards wall. Pipe (D) will go through the wall thimble (F). Be careful not to dislodge the thimble. Position stove not closer than 1" to the wall.
- 5) **NOTE:** Make sure that you leave enough clearance between the wall and the back of the unit so that when you open the hopper lid it will not hit pictures on the back wall. It is recommended that you leave 4-6" between the wall and the back for the unit for easy access.
- 6) Install type "PL" termination cap (H) with rodent screen cap (optional) on outside end of pipe. **Note:** The end of the exhaust pipe must extend a minimum of 12 inches from the outside of the building. Rodent screen cannot be less than 3/8" opening mesh.
- 7) If installing with combustion air from outside, cut a separate hole through the wall for the fresh air tube (E). This tube must be 3" minimum diameter steel only. Connect outside air pipe inlet on stove (C). This tube must be terminated with a 90 degree elbow or hood. Care must be taken not to interfere with the operation of the combustion-air back draft damper. Always make sure that it moves freely.

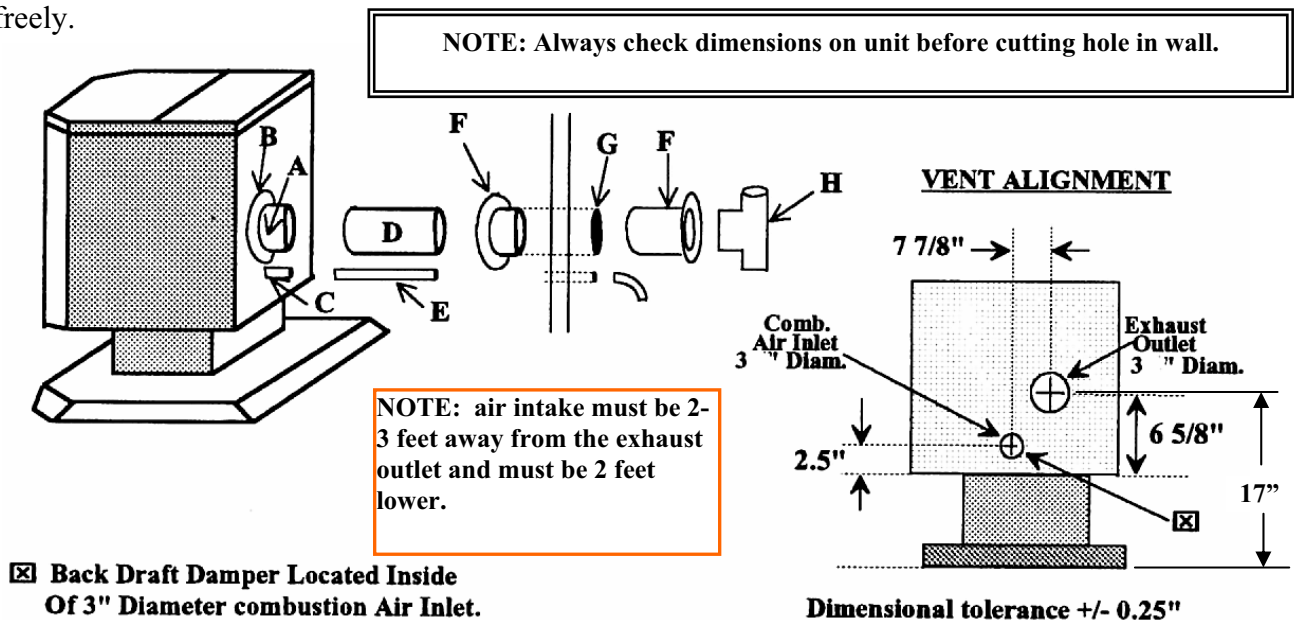

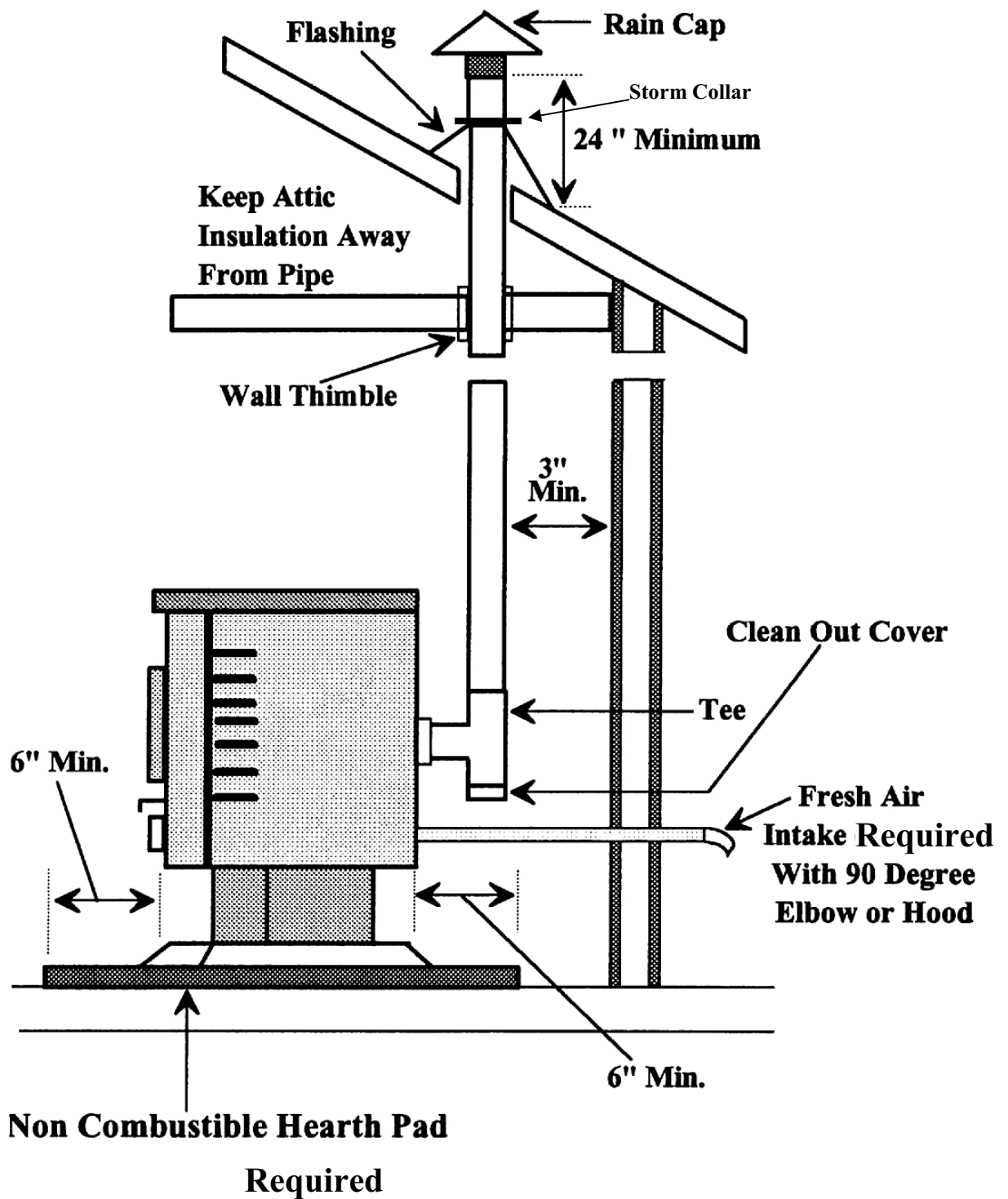

INSIDE VERTICAL PIPE WITH ROOF TERMINATION

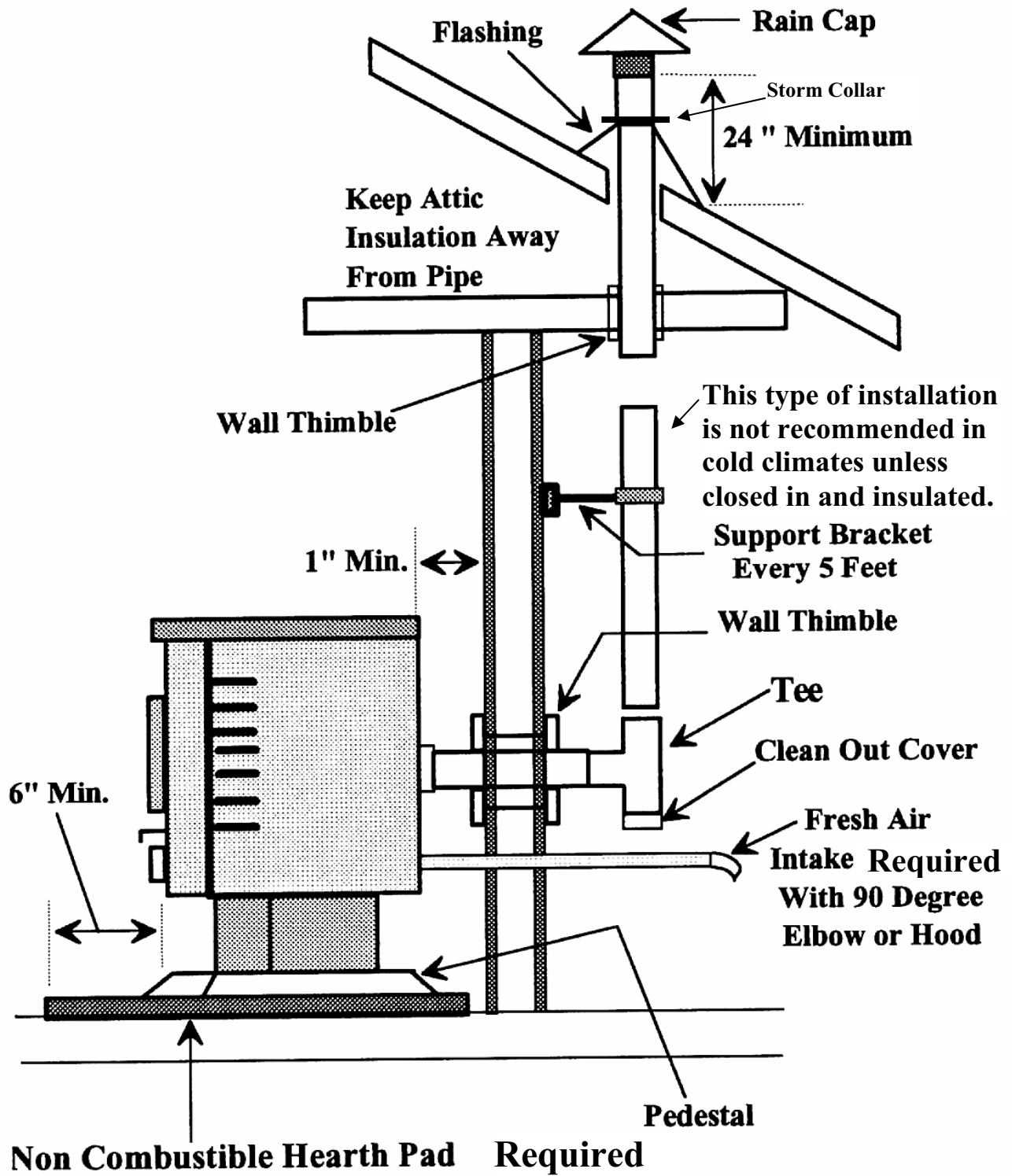

THROUGH THE WALL, VERTICAL PIPE INSTALLATION WITH TERMINATION THROUGH THE ROOF

WARNING: Unless the venting is enclosed and insulated this installation will cause poor venting and serious creosote buildup in cold climate areas.

FIREPLACE INSERT INSTALLATION REQUIREMENTS

The **Magnum Countryside Model 3502 Fireplace Insert** may be installed in a masonry factory built fireplace or on a non-combustible floor as shown below. **NOTE:** When installing as a fireplace insert, the unit must extend out of the fireplace opening 12" to accommodate access to the circuit board panel, draft slide (located on the left side of the insert) and the top front hopper lid (to fill the hopper with fuel).

CAUTION
 There are serious consequences for using makeshift compromises during installation. Always use proper listed materials. Do not cut corners. Serious complications and possible safety risks may occur. Always use a certified installer.

NOTE: The circulation air inlet fins must be inside the room. Do not put the shroud in front of them.

NOTE: Existing fireplace dampers must be locked in the open position, seal any openings between the masonry of the fireplace and the facing masonry.

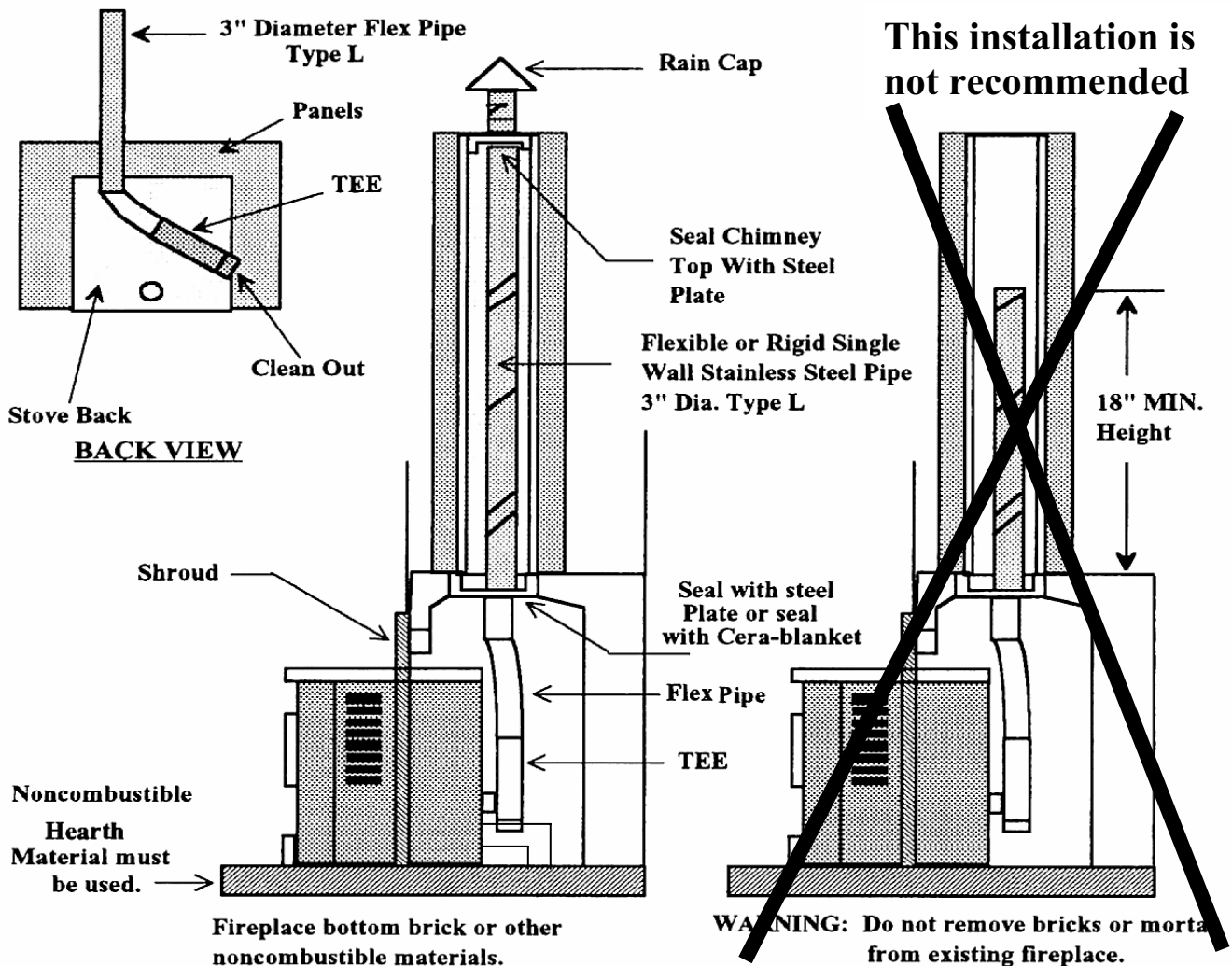

FIREPLACE INSERT INSTALLATION CONTINUED.....

The **Magnum Countryside Model 3502 Fireplace Insert** requires a fireplace shroud for proper installation. The shroud is designed to slip over the stove-top between the front and back hopper lids. Shrouds can be customized for particular installations (custom order).

- 1) Position unit so that the shroud can be slid over the top lid behind the sliding draft control knob (located on the left side of the unit). Alternate Method: Open the back lid, slide shroud over sides, slide onto front lid, close back lid, slide onto back lid.
- 2) Attach 3" flex pipe connector to the 3" exhaust tube on the back of the unit. Allow enough flex pipe to pull the unit out of the fireplace opening for maintenance but be careful not to crimp pipe when pushing insert into place.
- 3) You may silicone around the fireplace shroud connecting it to the stove or leave the shroud loose for easy removal during vent cleaning. This will have to be done after pushing unit into place. Be sure to route the stove plug-in-cord through the shroud before pushing the unit into place.

PERIODIC MAINTENANCE

At least once a year the chimney and smoke chamber must be inspected and cleaned. The fireplace insert will have to be removed for the purpose of inspecting the fireplace insert and the chimney. The buildup of fly-ash in the chimney pipe will cause the unit to operate inefficiently. Continued use will cause malfunction of the unit. Venting should be checked at least monthly

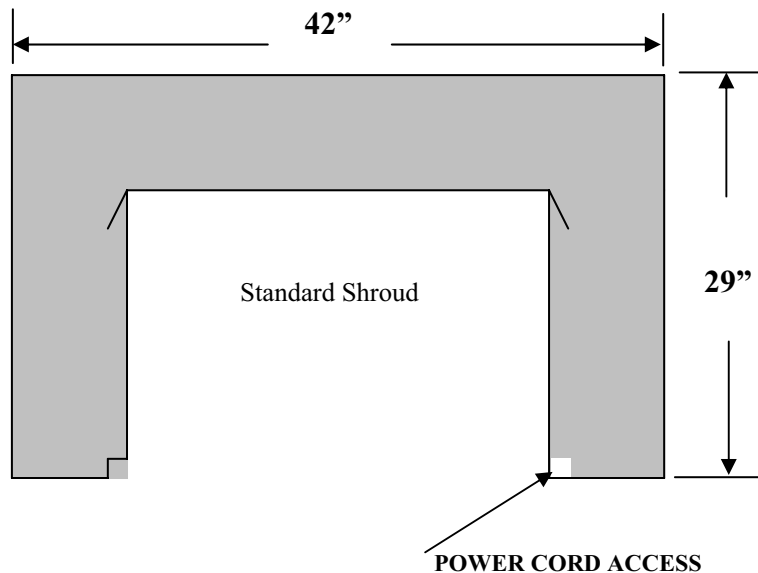

To Remove the Fireplace Insert:

Disconnect the power supply, slide the insert forward leaving the shroud in place and being careful not to dislodge the chimney flex pipe, open the clean-out to empty the fly-ash, inspect chimney conditions and connections, clean as needed, slide insert back into place, make sure that all chimney connections are in place and then re-connect the power supply.

It is important to do regular cleaning and maintenance to an insert as the venting is long and will build up with fly-ash.

GLASS MAINTENANCE, ADJUSTMENT, REMOVAL AND REPLACEMENT

Your **MagnuM Countryside Corn/Pellet Stove** comes to you with the glass door installed in place, ready for use. The glass is surrounded on the edges with a gasket and seated in a glass channel. It is held in place with two (2) clips on the top and two (2) clips on the bottom

REMOVAL OF BROKEN OR DAMAGED GLASS

Open the door and lift off of hinges. If the door is tight, tap gently on the bottom of the door with your hand or rubber hammer. Lay door down on newspaper with glass clips facing you. Using a #2 Phillips screwdriver, loosen the screws and take off the glass clips. Remove the broken glass carefully and discard. Check to make sure that the gasket material under the glass is in good shape. You can get this material from the factory or from an authorized **MagnuM Countryside** dealer if it needs to be replaced. Reverse the above procedure for replacing new glass. **When installing the new glass make sure that the glass is not sitting on top of any obstruction. The glass will break when tightening the screws if the glass is on the gasket. Hold the glass toward the top of the door glass channel when tightening.**

WARNING

**Do no operate unit with broken glass.
Do not substitute original factory glass.
You must use only factory authorized glass:
(8^{11/16}" x 15^{1/8}" high temperature Ceramic glass, 5mm thick)
Do not slam door shut.
Do not strike glass.
Do not use abrasive cleaners.
Do not clean when glass is hot.**

CLEANING THE GLASS

When the fire is first started, it will produce some smoke. The smoke might accumulate on the glass surface. Before the fire gets hot, open the door and wipe the glass surface off with a damp rag. Do not touch the surface with your hands. If after constant use, the glass is dirty; you must clean the glass so that it will not become etched with the fly-ash. When the glass has cooled off, take a damp rag, put a little fly-ash from the unit on it and clean the glass. If this does not clean the glass use a special glass cleaner provided by your **MagnuM Countryside dealer**. **We have found that Amway crème glass & chrome cleaner works real well.**

Glass Hold Down Clip (4)

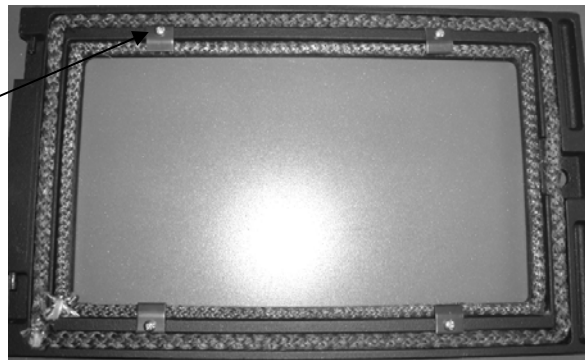

STOVE CONTROLS

Front view

Adjustable Air Deflector
Move up or down to adjust air direction

Adjustable Door Handle
lifts up and turns to the left to open

Ash clean out slides (3500P & 3500L model) Pull out to empty ashes out of firebox area and back heat exchanger area. You will have to scrape the ashes down through the holes on the inside of the unit. (using the scraper tool) Make sure to push the slides all the way in when done.

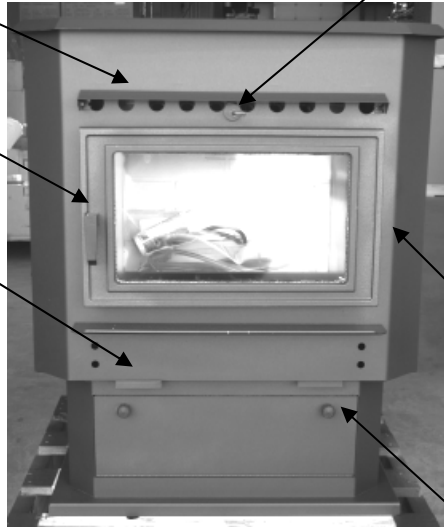

Sliding heat exchanger tube cleaning rod. Pull in and out to clean heat exchanger tubes.

There is a scraper provided with the unit for cleaning out the ash. There is a hole in one end for hooking onto the front heat exchanger tube rod for cleaning if the unit is hot.

If you want to, you can purchase an adhesive back hook and place it on the back panel of the unit to store the scraper tool. This can be purchased at any local hardware store.

Adjustable hinges. Loosen locking nut and move in or out to adjust.

Left view

Left Side

Circuit Board control panel. Open door and select heat and fuel stirrer settings. Top knob is the heat selector, lower knob is the fuel stirrer selector.

Manual Draft Adjustment control knob. Slide in or out to decrease or increase draft



Pedestal Ash Pan (3500P & 3500L models) Turn (2) knobs counter clockwise to open ash pan door, pull out ash pan (be sure to wear gloves) and empty into a metal sealed container. Make sure that the ash pan area is clean before putting the ash pan back into place. Close ash pan door and turn knobs clockwise until door is tight and sealed. NOTE: the unit will not operate correctly if the door is not closed and latched to get a proper seal.

Side view showing control operation

Slide Heat Exchanger Tube cleaning rod in and out to clean tubes
shown pulled out at least twice a day

Adjustable Air Deflector

Ash Cleanouts located on the left and right side of the front of unit. Slide out for cleaning. (3500P & 3500L models) **shown pulled out**

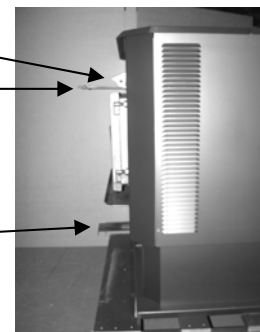

LIGHTING INSTRUCTIONS

Before lighting your **Magnum CountrySide** for the first time make sure that all items are out of the hopper and firebox area. Turn the heat setting and fuel stirrer knob to the off position and push the manual draft in as far as it will go. **Note:** If using a wall thermostat option, make sure that the thermostat is turned up above room temperature. The unit will operate on low fire if the thermostat is turned down. **Always start the fire on the # 3 heat setting.**



- ✓ Place a small handful of wood pellets or fire starter in the firepot.
- ✓ Squirt a small amount of fire starter gel on top of the wood pellets. (Evenly across the wood pellets)
- ✓ Light the fire starter and wait app. 1-minute for it to start burning.

- ✓ Turn the heat setting knob to the number 3 setting and pull out the manual draft knob approximately ¼ inch. (more or less if necessary)

- ✓ Turn the Fuel Stirrer knob to the number 1 setting and let it rotate a couple turns to stir the firestarter and wood pellets together. Then turn the fuel stirrer off until the fire is burning good. (approximately 1 minute)

- ✓ Once the wood pellets are burning good enough for the fuel stirrer to stay on (app. 1 minute), turn the fuel stirrer to the number 1 setting and leave it on. Adjust the manual draft knob (located on the left side of the unit to the left of the circuit board) so that there is approximately ½ inch of fuel in the bottom of the firepot. This level cannot be determined quickly. Minor adjustments will have to be made until the main fuel starts coming in and the unit is up to temperature.

- ✓ **NOTE: Even if you are burning corn or other fuels in your Magnum Countryside, wood pellets make an excellent source of starter fuel. Corn takes too much starter gel to get lit and up to temperature. (DO NOT START THE FIRE WITH CORN)**
- ✓ Three minutes after the heat setting knob is turned to the number 3 setting the fuel will start to feed into the firepot. If the firepot begins to fill up with unburned fuel, open the manual draft knob a little to burn up the excess fuel. If the fire is going out because there is too much fuel coming in, turn the heat setting knob off and then turn back on. This will give you another 3 minutes before fuel feeds in. **You can also open the hopper lid.**

- ✓ If the fire is burning too fast and the fuel is being burned up too quickly, push the manual draft knob in a little to slow the fire down. This should be done in small 1/16” increments so that the fire doesn’t change too quickly.

- ✓ Once the fire has established itself (usually 10 to 15 minutes) adjust the manual draft knob so that there is approximately ½ inch of fuel in the bottom of the firepot. **Do not let the fuel build up any higher than that or it will cause the fire to burn dirty and you will get excessive ash. If the fuel level is too low (below ¼”) the fire may go out.**

Damper Control Function

The damper control knob is located on the left side of the unit close to the circuit board access panel. You pull out on the knob to increase the air to the firepot and push in to decrease the air to the firepot. The proper setting will vary from home to home so fine tuning has to be done in the home with the fuel that you plan to use.

When you change fuel sources it may become necessary to readjust the damper control knob. You should not have to continually adjust the manual knob except when using the high fuel setting. The circuit board automatically adjusts the air to the firepot on the settings from 1 to 4.

CIRCUIT BOARD FUNCTIONS

Startup

When the circuit board is energized (unit plugged in) there is a 15 second purging of the auger tube to allow fuel to enter the firepot. To initiate the startup, turn the heat setting knob to the number 3 setting. If the unit is started on the 1 or 2 settings the firebox temperature may not raise fast enough for the low limit sensor to engage. When the heat setting knob is turned on, the draft blower starts but the auger feed does not start feeding fuel until after 3 minutes.

The fuel stirrer can be turned on at this time and run for a couple of turns to stir the fuel. After the fuel is lit, the fuel stirrer can be left on the number 1 setting. Corn may require a higher setting if the moisture content is high or if the corn has high starch content. Wood pellets may require a higher setting if the ash content is high or if you are running the unit on the high setting.

New feature if fuel stirrer control is left in the off position more then 10 minutes it will automatically shut the stove down.

NOTE: Make sure that the wall thermostat is turned up so that the unit will start on the number 3 setting.

If the fire is not hot enough to engage the low limit sensor, (within 20 minutes) the circuit board will cycle through the shut down mode and the unit will shut down. The green indicator light will blink rapidly to show that the unit is not operating properly. To restart the system, simply turn the heat-setting knob to the off position and turn back on to the number 3 setting.

Once the unit is operating at the proper temperature (usually 10-15 minutes), select the heat setting that you want, adjust the manual draft adjustment knob so that the fuel is app. ½ inch thick in the bottom of the firepot. **(There should be a nice bed of red coals in the bottom of the firepot).**

The number 3 heat setting is best for corn and the number 4 heat setting is best for wood pellets for a high fire burn. The high heat setting should only be used if the home is over 2500 square feet or the weather is extremely cold. The high heat setting is intended for use with wood pellets and the highest heat setting for corn would be the number 4 setting.

The unit is not designed to be operated for long periods of time on the highest setting. Optimum efficiency is achieved by using lower settings. It is also recommended that the unit not be run for extended periods of time on the number 1 setting. The draft blower and venting will fill up with fly ash after a long period of time. Once a day pull the manual draft knob out all the way and turn the unit up on high. Run it this way for a few minutes to clear the venting and draft blower. It is good to run the unit on one of the higher settings at least once a week to clear the system and eliminate the buildup of fly-ash.

Shutdown

To shut the unit down simply turn the heat setting knob to the off position and the system will enter the shut down mode. **The fuel stirrer, room fan and exhaust blower** will continue to operate until the low limit safety sensor tells it that the fire is out and the firepot has gone through its cleaning cycle. After this time the fuel stirrer will shut off. When this happens the fuel auger will go into the purging cycle and auger a small amount of fuel out of the auger into the firepot. Then the entire system shuts down.

Before starting up the Magnum Countryside Biomass Corn/Wood Pellet unit again, it is important to remember to shut off the fuel stirrer so that the fire can be started properly. It will also ensure that the fuel stirrer will not start with someone having his or her hand in the firepot area.

SETTING THE DRAFT

A proper draft setting is crucial to the successful burning of solid fuels. Draft refers to the amount of air flowing through the burn chamber of your stove. Too much or too little draft will cause your stove to burn improperly and may result in the fire burning out. Please follow these guidelines carefully as you operate your stove to achieve maximum efficiency and enjoyment.

- ✓ The amount of draft required for your stove to burn properly will depend upon your installation and the fuel you use. You can set your draft by looking at the flame and following these guidelines. The manual draft knob is the rod and knob on the left side of the stove. Pulling the knob out increases the draft and pushing the knob in decreases the draft. A little movement of the knob goes a long way to changing the flame. It may take several trial and error adjustments on the draft to achieve the correct setting.
- ✓ The flame should be an “active” flame. A flame that moves around lazily and emits visible smoke needs more draft. To give the fire more draft, pull the damper out 1/8” and check the flame again. If the status of the flame has not changed, move the damper another 1/8” until you get a clean “dancing” flame. **If moving the damper does not change the fire, you might have negative pressure in the home.**
- ✓ The base of the flame should be blue in color and the top of the flame should be yellow.
- ✓ If the flame does not have enough draft, fuel will build up in the firepot and eventually smother the flame. If this happens, or if you notice the firepot is filling up with partially burned fuel, open the damper 1/8” at a time until the fire is clean and dancing.
- ✓ If the flame has too much draft, the flame will look like a torch in that it will be moving rapidly and blowing fuel out of the firepot. If you find that you have this condition, move the damper inward 1/8” at a time until the condition of the flame changes.

MAINTENANCE INSTRUCTIONS

DAILY MAINTENANCE

- ✓ **Surfaces on the front of the stove will be extremely hot during operation.** Always wear heat resistant gloves to perform periodic maintenance.
- ✓ Using the hole in the handle end of the clean-out tool, move the heat exchanger rod in and out 10 times and return it to operating position, all the way in. This should be performed twice a day to maintain peak efficiency.

Heat Exchanger Rod
with Handle Attached

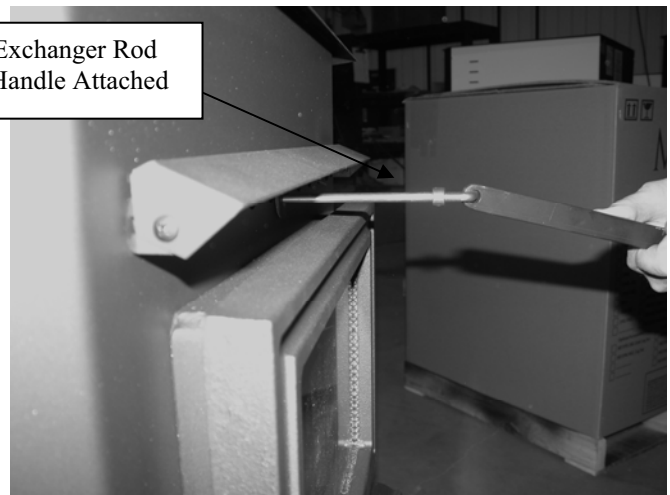

Left side heat exchanger shown



- ✓ Using the clean-out tool, tap the side heat exchangers that are located on the left and right sides of the firebox. When you open the door, they are located directly inside to the left and right. When you tap the sides with the clean-out tool the loose fly-ash will drop out of these slots.

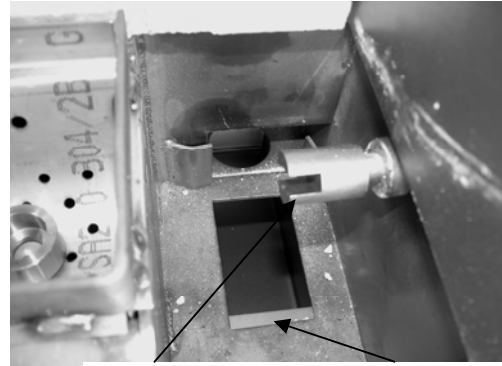

Shown with cleanout door pulled out to open back cleanout hole and front cleanout.

- ✓ (3500P & 3500L model) Pull the lower front ash cleanouts out and scrape any fly-ash down into the pedestal ash pan. Push them back in all the way.

MAINTENANCE INSTRUCTIONS CONTINUED...

- ✓ While you are tapping the side heat exchangers, we recommend that you pull the draft knob all the way out for a minute or two and put the unit on high fire. This will allow the unit to self-clean the heat exchanger area, the draft fan and exhaust chimney pipe.
- ✓ If a clinker ball develops in the firepot, scrape it out with the clean-out. You may have to do this once or twice a day depending on the moisture content of the corn. If this is not cleaned out, it could cause the fuel stirrer to jam. Clinker balls are a direct result of excessive corn moisture and they do not indicate a problem with the stove. AES highly recommends an additive called "Clean Burn" be added to your corn to eliminate these clinkers. Contact your local **MagnuM Countryside** dealer for availability and cost.
- ✓ Open the stove doors and wipe the inside of the glass with a damp cloth as needed.

SPECIAL CLEANING/OPERATIONAL INSTRUCTIONS WITH UNIT SHUT DOWN:

3500P & 3500L Models: After cleaning or when operating the 3500P & 3500L models you need to make sure that the clean-out plates are in the closed position. Push the front (2) clean-out slides all the way in and make sure that you have replaced the left & right clean-out plates that are located on the inside of the unit. (These plates are located inside the firebox to the left and right of the firepot in the lower corners of the firebox.) If these plates are not in the closed position the unit will burn dirty.

3502 Insert Models: After cleaning or when operating the model 3502 models you need to make sure that the clean-out plates are in the closed position. There are clean-out plates that need to be closed. These are located to the left and right of the firepot inside the firebox in the back lower section of the firebox. Remove the ash pan, clean out all the ash using ash vacuum and replace the ash pan. Make sure to lock the ash pan in place.

All models have a heat exchanger tube cleaning rod to clean the heat exchanger tubes. This should be done twice a day if you are using wet or dirty fuel.

3500P & 3500L models have (2) front cleanout slides that must be in the closed position when burning the unit.

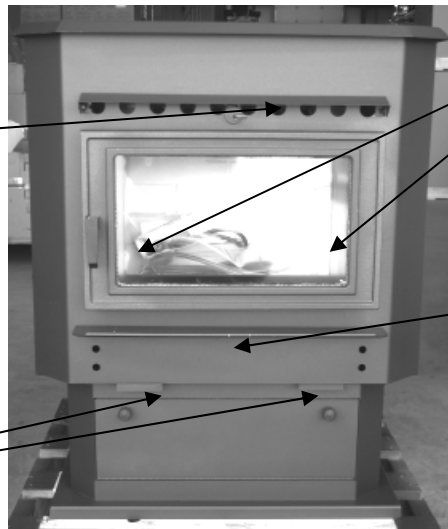

All models have clean-out plates located inside the door in the lower left and right corners of the firebox. Make sure that these are closed when operating the unit.

3502 models make sure that the ash pan is locked in place.

WEEKLY MAINTENANCE

- ✓ Set the stove on high fire. Open the draft to 100% and allow the stove to burn for 15 minutes. Resume desired heat and draft setting.
- ✓ Shut down the stove as directed in the operating instructions. Allow the stove to cool to room temperature. Remove the small clean-out slides in the lower corners of the firebox. Tap the sides of the burn chamber with the clean-out tool. Do not tap the firewall behind the burn box as it may damage the insulation. Using the clean-out tool, scrape the fly ash from the clean-out chambers toward the front of the burn chamber. Remove the fly ash from the burn chamber and replace the clean out chamber doors.

Must be positioned as shown to remove firepot

- ✓ Remove the ash pan and dump the ash into a metal container.



Ash pan

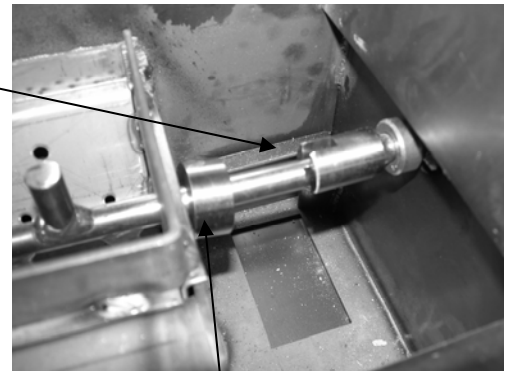

Coupler Shaft

- ✓ Remove the firepot by stopping the fuel stirrer in the upright position, slide the collar off of the fuel stirrer coupler shaft and pull up and out on the firepot. Using the clean-out tool, remove any ash that might have built up in the system or air intake.

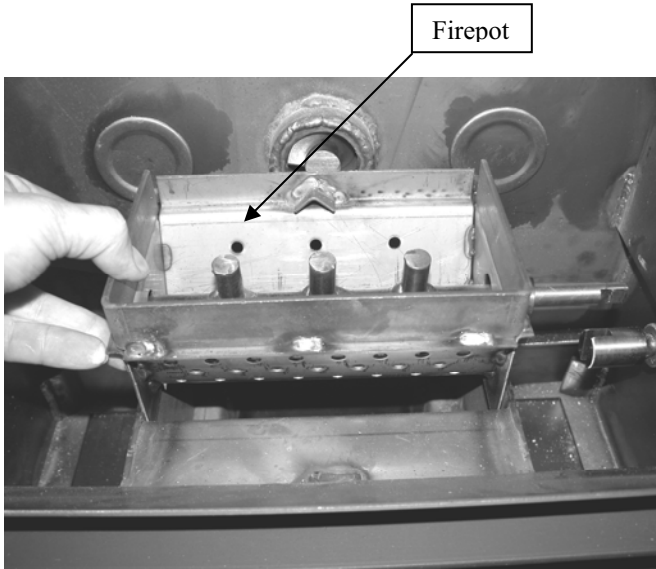

- ✓ Cleaning of the exhaust system will depend upon the ash and debris content of your fuel. If your fuel has a high ash content and/or significant debris in it, your exhaust system will require weekly cleaning. Cleaner fuels will allow for monthly cleaning of the exhaust system. Remove the exhaust pipe from the back of your stove and remove any ash that may have collected in the pipes. Replace the pipes to the stove and seal with high temperature seal tape. If you have installed proper clean out tees you will not have to take the chimney sections apart.

- ✓ While you are doing the weekly cleaning, have the unit set on high and the draft knob all the way out. This will help draw the fly ash to the back of the stove. (Remember the unit is not burning.) After cleaning, push the draft knob back into the stop collar.

REMEMBER: A clean unit burns efficiently and will remain trouble free!

- ✓ While you are doing the monthly cleaning, it is recommended to vacuum inside of firebox. Remove firebrick located on the inside of the unit. Then remove the knock-out plugs located on the panel as shown. Thoroughly vacuum ash out of area using a ash vacuum cleaner.

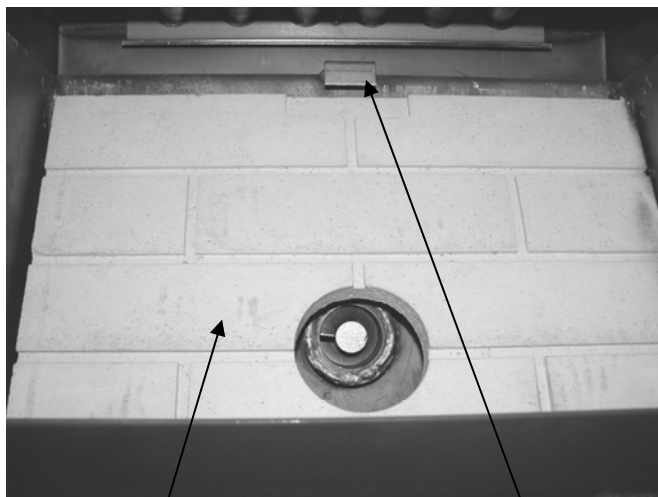

Firebrick

Firebrick retaining clip

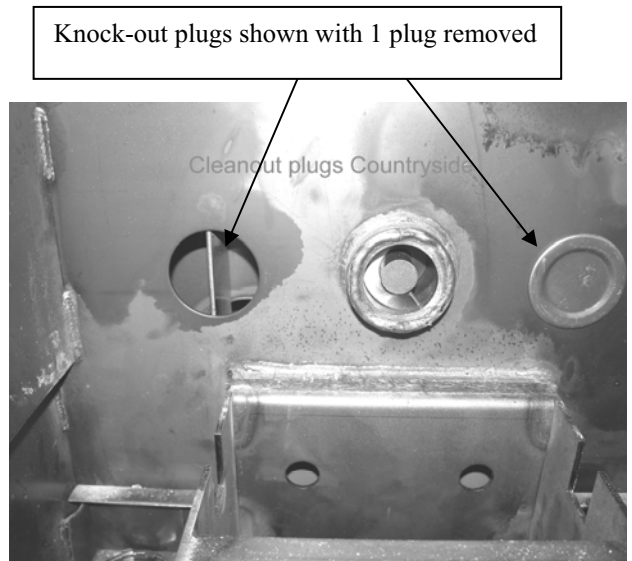

SPRING CLEANING:

When the heating season is over make sure that you clean out all of the fuel in the hopper, firebox area, ash pan and firepot area corn can accumulate moisture over the summer months causing the unit to rust and the fuel to mold.

It is recommended that prior to shutting down the unit in the spring, run the unit on the higher settings for a day to help clean out the heat exchanger system, venting system and firebox area.

When the unit is cleaned out, take the venting apart, clean out the fly-ash, rinse the venting out with a water hose and let dry, take the draft blower off and clean, clean out all areas such as back heat exchanger and lubricate the auger, auger tube, firepot area, fuel stirrer shaft and bearings and hopper area with a light oil. (Something like Pam cooking oil works great to coat the inside of the unit and the moving parts.

Clean the glass, doors and outer cabinet so that you are ready for the next heating season.

AUTOMATIC SAFETY FEATURES

WARNING

These automatic safety features must not be bypassed.

✓ **Power Outage**

During a power outage, the stove will shut down safely. It will not automatically restart when the power returns, unless the exhaust is still up to temperature (see “Lighting Instructions” page 21).

✓ **Overheating**

A high temperature switch will automatically shut down the stove if it overheats. The stove will need to be manually re-lit. Allow 45 minutes before re-lighting.

✓ **Auger Cut-Off (3500P & 3500L ONLY)**

When the back hopper lid is opened the fuel auger stops. It will resume operation when the lid is closed. The hopper lids must be kept closed for proper operation. If the lid is left open the fire will go out. If fuel gets lodged in the back hinge area of the hopper, when you close the lid, the switch might not work. Always make sure that the sealing surface is clear of fuel before closing the lid.

HOPPER AUGER SAFETY SWITCH LOCATION

Auger Safety Switch Rod

The hopper auger safety switch is mounted in the back of the hopper, up next to the back lid. The assembly is enclosed to keep the fuel from entering the switch locale. When the lid is opened it cuts power to the auger motor. Power is resumed when the lid is closed. If the lid is left open for more than a couple of minutes the fire will go out. Always have the fuel ready to load into the hopper before opening.

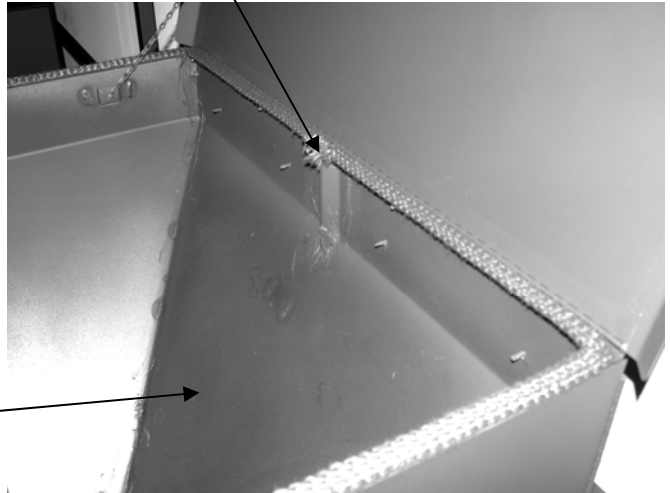

Inside of hopper

Auger Safety switch



THERMOSTAT INSTALLATION

- ✓ The **Magnum Countryside** can be installed with and operated by a wall-mounted thermostat. However, a wall thermostat is not provided with the stove. A wall thermostat can be purchased from your reseller or at most home improvement centers or hardware stores. The wall thermostat needs to be for a low voltage system. Most thermostats will have instructions with them as to where to place them in your room. Please follow the thermostat manufacturer's instructions carefully.
- ✓ There are two (2) male spade terminals on the back of the control panel near the center. Connect the two wires from the wall thermostat, one to each of these spade terminals. **Needed:** 2 female ¼" insulated terminals.
- ✓ Make sure that the wires are routed to protect them from hot surfaces. Do not cross wires with circuitry on board.
- ✓ The circuit board is located on the left side of the unit. Remove the ¼" hex head screw and pull circuit board towards you. Lift the circuit board out of the housing. Do not crimp or stretch the wires leading from circuit board pigtail. **(Unplug the power cord before working on unit)**
- ✓ Reinstall in reverse procedure.

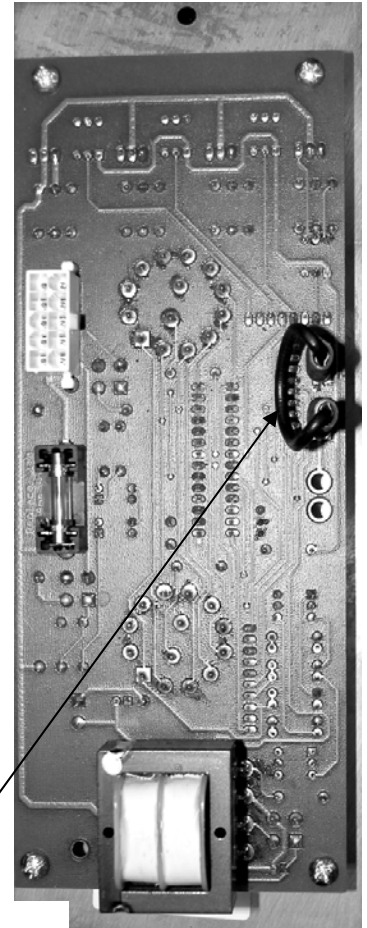

Two (2) ¼" male spade connectors, one for each wire from wall thermostat

It is a good idea to use the thermostat option to achieve uniform control over your heating needs. By setting the unit on a number 3 setting (this is the normal setting but can be any setting from 2-high) for high fire and letting the wall thermostat control it, the fire will drop down into a pilot fire after the home reaches the desired temperature.

If you are gone and the home requires heat, the unit will automatically resume the high setting when the thermostat calls for heat.

TROUBLE SHOOTING GUIDE

Unplug stove before performing any maintenance work. Do not work on unit when it is hot.

PROBLEM	CAUSES	SOLUTIONS
<p>Fire burns with a lazy, orange flame and/or fuel builds up in the grate and the window gets sooted up.</p>	<ul style="list-style-type: none"> ◆ Insufficient combustion air. ◆ Feed rate too high. ◆ Corn or wood pellets have too much moisture – need 14% or less; 10%-12% is ideal. ◆ Combustion/Exhaust blower plugged or going out. ◆ Venting plugged with fly ash or ice. ◆ House does not have adequate make up air (negative pressure) ◆ Ash Slides are pulled out or Ash Door left unlatched 	<ul style="list-style-type: none"> ✓ Remove any clinkers or ash from the firepot by using scraping tool. Shake ashes into ash pan. ✓ Clean out primary air in firepot holes if plugged. ✓ Empty ash drawer and clean out back heat exchanger by removing the lower access plates. ✓ Tap the side exhaust heat exchangers to clean them as shown on page 27 - 30. ✓ Change to a better grade of fuel if necessary. See page 7 regarding fuel quality. ✓ Check that damper control knob is adjusted properly. Pull out to increase fire burn. ✓ Check gasket seal around the door. If the door is loose, adjust the handle latch. A small adjustment can be made to the door seal by adjusting the door latch rod and /or the door hinges. Replace the door gasket if necessary. ✓ Check for blockage in the air inlet tube or exhaust pipe. Clean out as necessary. ✓ Check combustion exhaust blower impeller. This can be done by removing the exhaust pipe and shining a light into the tube. ✓ Replace combustion exhaust blower if necessary. <p>NOTE: Negative pressure in a home is a serious issue. All Magnum Countryside appliances should be installed with outside air hookups. Also make sure that adequate ventilation is supplied for the rest of the home or the unit will become the air intake causing problems. Make sure that all doors/slides are closed</p>

PROBLEM	CAUSES	SOLUTIONS
<p>? Fire goes out or stove shuts down automatically.</p>	<ul style="list-style-type: none"> ◆ Hopper is empty. ◆ Fuel is not feeding. ◆ High limit temperature switch has tripped. ◆ Combustion air too high. ◆ Fuel feed rate is too low. 	<ul style="list-style-type: none"> ✓ Refill hopper. ✓ See “Pellets will not feed” below. ✓ Allow stove to cool for 1 hour and relight. If the stove has been operating at a medium to high burn and the convection fan has been turned down low, then the fan should be turned up higher. If this problem persists, particularly at lower burn rates, then the high limit snap switch should be replaced by your authorized Magnum Countryside dealer. ✓ Adjust the damper to reduce combustion airflow. ✓ Have your Countryside reseller adjust the fuel control.
<p>? Fuel will not feed.</p>	<ul style="list-style-type: none"> ◆ Hopper is empty. ◆ Auger, circuit board, high limit switch tripped ◆ Foreign object caught in auger ◆ Fuel is dirty or wet ◆ Auger, circuit board, pressure switch or relay. 	<ul style="list-style-type: none"> ✓ Check contents of the hopper. Add fuel if necessary. ✓ Check all operation, fuses ✓ Clean out auger system ✓ Have your MagnuM Countryside dealer diagnose the problem and replace the parts.
<p>? Stove runs for 30 minutes and then shuts down.</p>	<ul style="list-style-type: none"> ◆ Exhaust gas is not up to temperature. Started on too low of Setting. Must be # 3 ◆ Low limit snap switch not operating correctly; may be defective. ◆ Wires to either the low limit snap switch (mounted on the side of the firebox) are loose or disconnected. 	<ul style="list-style-type: none"> ✓ Relight the stove. Start on # 3 setting ✓ Have your MagnuM Countryside dealer replace the low limit switch. ✓ Contact your Magnum Countryside dealer for service.
<p>? Blower will not shut off after the fuel has been switched off and the stove has cooled down.</p>	<ul style="list-style-type: none"> ◆ Low limit snap switch has failed in the closed position. ◆ Unit has not cooled down yet. 	<ul style="list-style-type: none"> ✓ Have your MagnuM Countryside dealer replace the low limit snap switch. ✓ It can take up to 1 hour for the unit to cool down enough for the blower to shut off. If it takes longer than 2 hours for the blower to shut off or if it fails to shut off contact your local MagnuM Countryside service technician.

PROBLEM	CAUSES	SOLUTIONS
<p>? Blower will not operate.</p>	<ul style="list-style-type: none"> ◆ No power to stove. ◆ No power to control board. ◆ Blower has overheated due to dirt on blades or motor ◆ Blower is defective 	<ul style="list-style-type: none"> ✓ Check to see that the stove is plugged into the wall outlet. ✓ Check to see if your circuit breaker has “tripped”. ✓ Clean blades and motor, replace if needed. ✓ Check wire connection between the high limit snap switch and the terminal block.
<p>? Soot or fly ash in the house.</p>	<ul style="list-style-type: none"> ◆ Cleaning the window, particularly when the stove is operating. ◆ Leakage on the joints between the combustion fan, exhaust pipe and “PL” vent. This will be evidenced by dust on the impeller of the convection fan and in the heat exchanger tubes. ◆ Using a conventional vacuum for cleaning. Ash will bypass and enter the room. ◆ Negative pressure in home sucking ash/soot out of venting and unit ◆ Fireplace insert installation: If the existing fireplace opening was not thoroughly cleaned and painted before the insert was installed, then the convection fan may be picking up the fireplace dust, soot or ash and blowing it into the house. 	<ul style="list-style-type: none"> ✓ Clean the glass when the unit is not running ✓ Seal any leaks in the exhaust system with RTV high temperature silicone sealer. ✓ Use approved ash Vacuum ✓ Correct negative pressure situation ✓ Pull the insert away from the fireplace opening. Thoroughly clean the opening and paint the inside of the opening with latex or an inexpensive spray paint to hold the finer particles of dust.
<p>? Buildup of soot on glass, venting and heat exchangers</p>	<ul style="list-style-type: none"> ◆ Dirty fuel ◆ Wet Corn (above 15% moisture) ◆ Inadequate air supply ◆ Negative pressure in home ◆ Air wash plugged or out of adjustment 	<ul style="list-style-type: none"> ✓ Make sure you have clean fuel ✓ Dry the corn down to 11-12% moisture if possible or mix with wood pellets ✓ Pull manual draft control out slightly to make sure that there is app. ½ inch of fuel in firepot ✓ Install outside air to unit and make sure that the home has adequate make-up air. (suggested 6” make-up air into basement) ✓ Clean air-wash bracket located on bottom of glass door ✓ Adjust glass so that there is a 1/16th gap in the bottom
<p>Fuel stirrer keeps jamming/ breaking</p>	<p>Buildup in firepot, dirty wet fuel, poor quality fuel, negative pressure in home</p>	<p>Add clean burn additive Use clean, dry approved fuel Correct negative pressure situation</p>

CAUTION: When performing any internal electrical maintenance

- Moving parts inside of the cabinet may cause injury. Do not operate unit with panels removed or open.
- HOT parts. Do not operate the unit with panel open.
- Risk of electrical shock. Disconnect power before servicing unit.
- In the event of component failure, replace with original factory equipment.

IMPORTANT: Electrical work must be performed by an authorized technician.

PROBLEM	CAUSES	SOLUTIONS
Fuel burns off to quickly, have difficulty keeping a pilot fire.	Air shutter is open to far. Over drafting on a vertical install. Outside air is not hooked up Positive or negative pressure in home is affecting the units operation	Adjust your air shutter to a more closed position. A chimney restrictor may need to be installed. Consult with your Magnum Countryside dealer. Make sure that the installation is correct and nothing is affecting the furnace room
Foreign object caught in the auger and will not turn.	Accidental object in fuel.	If there still is a fire, let it extinguish and let furnace cool down. Unplug unit after the fire has exhausted. It will be necessary to clean out hopper. As you are facing the furnace open the right hand side panel. The auger motor will have a small cooling fan on the back. Turn the fan counter clockwise until tension is off the auger. Open the front door of the unit and pull the auger out. Prying on the auger without loosening first can damage auger gear box.
Getting to much ash.	Dirty fuel Wet fuel Lack of clean combustion air. Dirty or plugged stove or venting. Poor exhaust vent configuration. Negative pressure present in the home Combustion motor going out. Use combustion enhancement system	Adequately screen corn. Dirty , wet fuel will produce excessive ash Take proper steps to check corn for proper moisture and to adequately protect from the elements to not take on moisture. Check damper control and check combustion air inlet for obstructions. Check all cleanouts and exhaust venting for obstructions. Refer to cleaning section of this manual. Call your MagnuM Countryside dealer to inspect installation and operation. Replace any bad parts. On higher heat settings combustion enhancement system will keep ash volume down.
The heat output is not as high as when the furnace was installed.	Wet or dirty fuel. Inadequate cleaning. Dirty room air filter. Change of fuel to lower BTU value Negative pressure or improper ductwork is causing unit to perform improperly	Wet fuel has a much lower BTU output. The furnace requires 14% or lower moisture corn. Dirty fuel does not produce adequate heat. Excessive amounts of fines interrupt the amount of corn delivered for burning and will decrease heat output. Clean heat exchangers daily, tap side exchangers, inspect furnace for air flow. Clean or replace filter. Have dealer check for proper installation and negative pressure in home.

WARNING: This section is only for qualified technicians.

Countryside Wiring Diagram (Ortech Circuit Board)

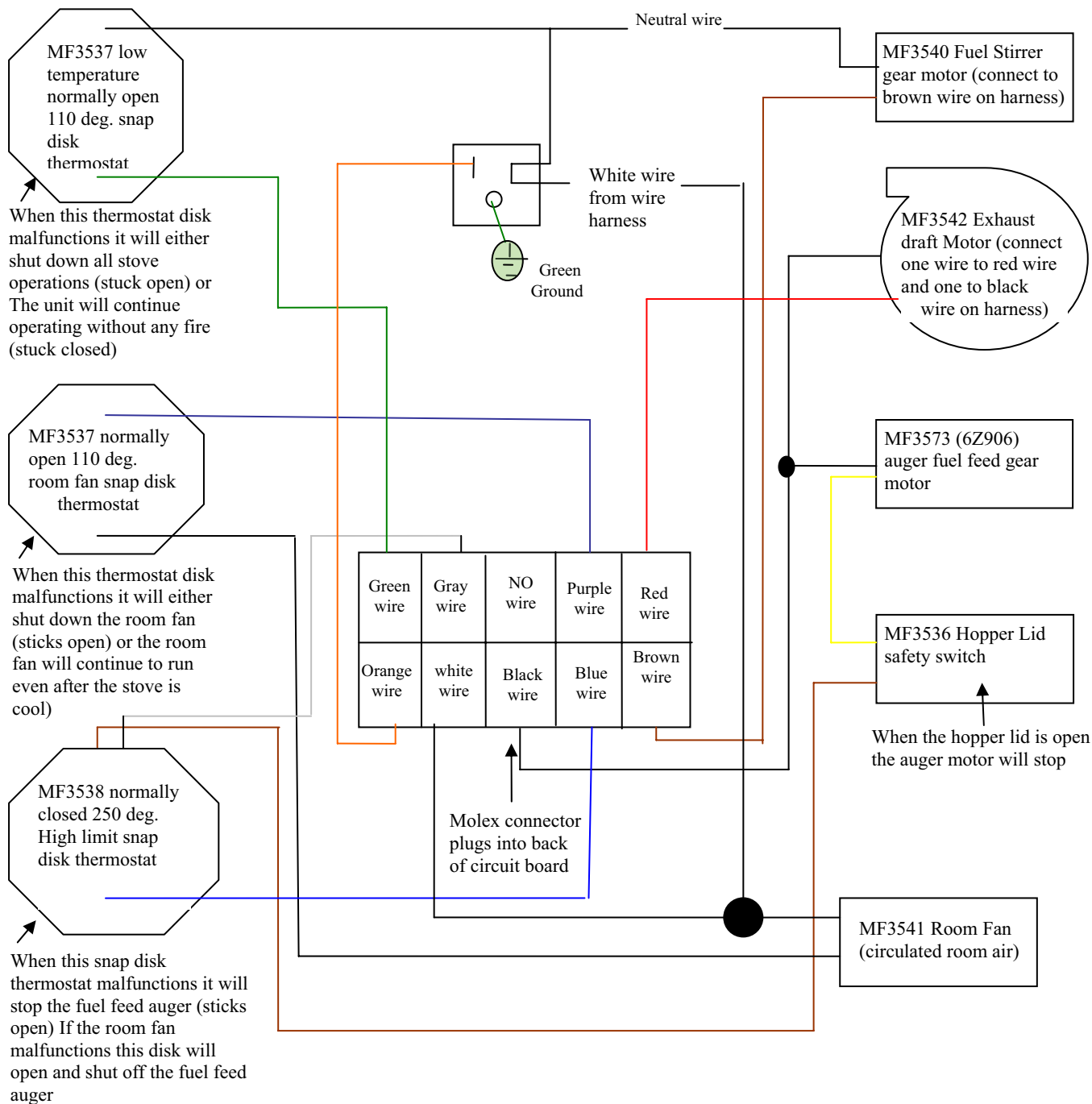

SETTING THE CIRCUIT BOARD

If the low fire heat setting is too low for the fuel that you are burning and the fire goes out, the number 1 or 2 heat setting can be adjusted through the access hole located next to the system indicator light. (2)

If the draft setting is too low on the number 1 or 2-heat setting, it can be adjusted through the access hole located next to the fuel stirrer knob. (1)

To adjust the settings, place a small screwdriver through the hole to the adjustment screws. Turning the screw clockwise increases the draft and counterclockwise decreases the draft. (1) Turning the screw clockwise decreases the fuel feed rate and counterclockwise increases the fuel feed rate. (2)

The systems indicator light will blink showing the number that you are on. There are 10 settings that are available with 1 blink being the lowest and 10 blinks being the highest. When you turn the adjustment screw to the next setting the light will blink the number that you are on and then the light will stay on. (Example: If the setting is turned to # 9 the light will blink 9 times and then stay on).

Draft Adjustment

Note: Number 1 on the draft adjustment setting is the lowest setting and on the Fuel Feed rate adjustment setting it is the highest feed rate. As you turn the adjustment screw clockwise 1 – 2 – 3, etc the draft (1) will increase and the fuel feed rate (2) will decrease.

The normal settings on both should be 1 blinks

THESE SETTINGS NEED TO BE MADE BY A QUALIFIED COUNTRYSIDE SERVICE TECHNICIAN.

The circuit board fuse is located on the back of the board. If the board does not work, check the fuse to make sure that it is good.

The thermostat hookup is located on the back of the circuit board. See thermostat installation.



Fuel Feed Rate Adjustment

DRAFT SLIDE GATE ADJUSTMENT

NOTE: The draft slide gate plate does not come as a standard piece with the unit. This must be purchased separate if needed.

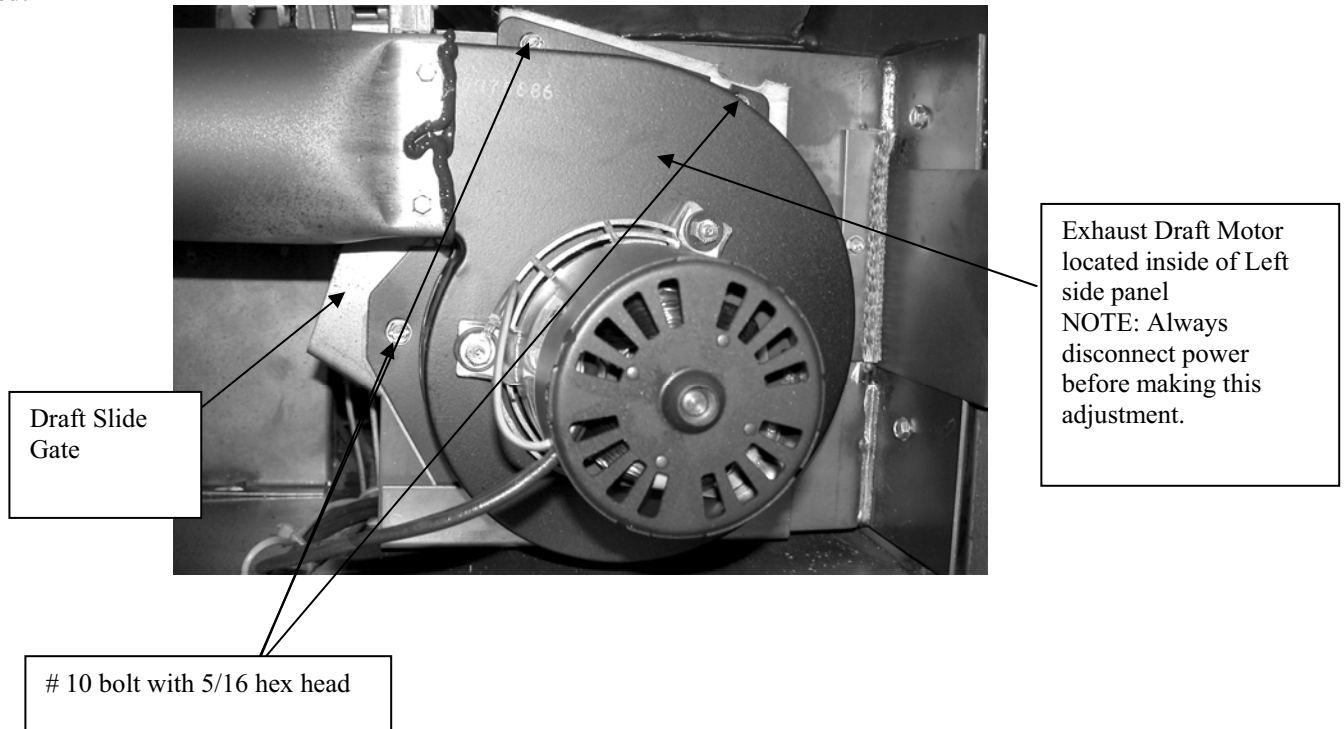

The normal operation of the MagnuM Countryside would be with the Draft Slide Gate open fully as shown. When the gate is in the fully open position, the plate will be against the mounting plate as shown. If the unit needs a draft correction adjustment, the bolts are loosened and the slide gate is rotated a few degrees at a time until the proper operation of the unit is achieved.

NOTE: This adjustment must be made by a qualified MagnuM Countryside installer

When rotating the slide gate, be careful not to damage the gasket. Re-tighten the bolts and check for leaks.

MAGNUM COUNTRY SIDE REPLACEMENT PARTS LIST

ORDER #	DESCRIPTION		
MF3511	Bronze Bushing (fuel stirrer shaft bearing) 2 pcs. (all countryside models)		
MF3512	Draft Slide / Electrical control access Knob		
MF3513	Fuel Stirrer (for Firepot)		
MF3514	Fuel Stirrer driver shaft assembly		
MF3515	Complete 24K Door Assembly (when purchased separate from unit)		
MF3516	Fuel Stirrer Chain (specify unit model, serial number and age)		
MF3517	Fuel Stirrer Sprocket (11-tooth sprocket on motor, 3/8" Diameter shaft)		
MF3518	Fuel Stirrer Sprocket (11-tooth sprocket on shaft, 1/2" Diameter shaft)		
MF3519	Complete Nickel Door Assembly (when purchased separate from unit)		
MF3521	Firepot Scraper assembly (all models)		
MF3522	Complete Black Door assembly (glass, handle, air-wash) (when purchased separate from unit)		
MF3522-CR	Return credit for MF3522 door when traded in for another door finish or for credit		
MF3523	Door Handle assembly (all models)		
MF3524	Black Air-Deflector kit (Complete Assembly) (when purchased separate from unit)		
MF3526	Door Latch shoulder bolt with 1/4-20 nut		
MF3527	Door Hinge (each) takes two (2) per unit		
MF3530	1 1/2" Corn Feed Auger (3500P, 3500L, 3502 models)		
MF3531	Door Glass (all models of Countryside & 7500 Corn Furnace)		
MF3535	Stainless Steel Firepot (for 7500 Furnace models & older Countryside models)		
MF3535-B	Stainless Steel Firepot (for all Countryside models)		
MF3536	Auger Safety Switch		
MF3537	Low limit / Fan Safety sensor 110 deg.		
MF3538	Hi-Temp safety sensor 250 deg.		
MF3540	Fuel Stirrer Motor (all models)		
MF3541	Room Air Fan (when purchased separate from unit)		
MF3542	Draft Blower (all models) when purchased separate from unit		
MF3549	Fireplace Insert Shroud (when ordered separate from unit)		
P7550	3500P Brick Board		
MF3570	Gold Air-Deflector kit (Complete Assembly) (when purchased separate from unit)		
MF3571	Nickel Air Deflector kit (Complete Assembly) (when purchased separate from unit)		
MF3573	Auger Feed Motor (all models with 1 1/2" dia. Feed auger)		
MF3577	Auger Coupler		
MF3578	Auger Motor Gasket		
MF3592	Millivolt Thermostats		
MF3593	Circuit Board, Ortech (current board used on Countryside)		
MF3598	24K Gold Queen Ann Leg Set - 4 legs & plating (when purchased separate from unit)		
MF3599	Nickel Queen Ann Leg Set - 4 legs & plating (when purchased separate from unit)		
MF3600	Black Queen Ann Leg Set - 4 legs & painting (when purchased separate from unit)		
MF3601	Ash Pan Weldment, Pedestal		
MF3609	Installation Hardware Packet		
MF3610	Exhaust Draft Motor Gasket (all models)		
MF3611-L	Ash Pan for Countryside Leg Unit		
P003213	Back Lid Assembly		
P003214	Front Lid Assembly		
P003015	Clean Out Slides		
P003051	Mounting Bracket, Air Deflector		
P003053	#8 x 1/2" Tek Screw 1/4" Hex		
P003054	#10-32 x 3/8" Philips Screw		
P003055	Air Deflector Nut		
P003067	Clean Out Rod		
P003073	Clean-out Door		
P003080	Rod (Hinge & Hopper Switch)		

5 YEAR LIMITED WARRANTY

This warranty is issued by American Energy Systems, Inc. (Manufacturer) and extends only to the original purchaser of this product.

This limited warranty will not become effective unless you have returned the attached warranty card within 30 days of your purchase. If you fail to do so, you may make no claim under this warranty. American Energy Systems, Inc. excludes and disclaims all implied warranties including, but not limited to, the implied warranty of merchantability.

For a period of (five) 5 years from the original purchase, Manufacturer will warrant, to the original consumer-purchaser, that all steel components are free from defects in materials and workmanship (except the firepot, which is covered by a one- (1) year warranty and glass which carries a lifetime warranty against heat breakage). There is expressly no warranty on the fiberglass rope gasketing, pyroboard insulation (brick backing), log sets, fuel stirrer, paint, brass or gold plated surfaces, baffles or handles.

The original manufacturer covers all electrical components, for a period of one year from the original purchase date. There is no warranty coverage for variances in fuel feed rates. BTU heat ratings will vary with different fuel conditions and is not considered a defect if the unit does not feed a constant amount of fuel.

The warranty covers defects in materials and workmanship in covered components, provided the product has been installed and operated strictly in accordance with manufacturers printed instructions. This warranty does not cover damage or breakage due or caused by mishandling, freight damage or misuse or unauthorized modification of the structure or electrical system.

This warranty will become null and void if unauthorized fuel is used. Seed Corn and Wax Corn is prohibited.

This warranty will become null and void if outside air is not connected to the appliance.

This warranty will become null and void if the appliances is not installed according to the guidelines and requirements of this manual along with proper venting, service, maintenance and operation of the appliance.

Before exercising this warranty, a local representative must inspect the unit to determine if the unit is defective. If the inspection reveals that the failure is due to defective material or workmanship and the part is covered by the condition of this warranty, the Manufacturer will, at its option, repair or replace the defective part. The sole duty of the Manufacturer and liability under this warranty is limited to the repair or replacement of the covered defective part. The purchaser shall assume all costs related to shipping the replacement parts or return of the unit to the factory for replacement. If it is determined that the defect was caused by the Manufacturer, the Manufacturer will cover the costs of shipping the repaired unit or replacement parts to the original purchaser.

REMOVAL OR REINSTALLATION COSTS ARE NOT COVERED BY THIS WARRANTY.

Neither the Manufacturer, nor the Reseller to the purchaser, accepts responsibility, legal or otherwise, for incidental or consequential damage to property of persons resulting from the use of this product. Any warranty implied by law, including but not limited to implied warranties of merchantability or fitness, shall be limited to one year from the date of original purchase. Whether a claim is made against the Manufacturer based on a breach of this warranty or any other type of warranty, expressed or implied by law, Manufacturer shall in no event be liable for any special, indirect, consequential or other damages of any nature whatsoever in excess of the original purchase price of this product. All warranties by Manufacturer are set forth herein and no claim shall be made against Manufacturer on any oral warranty or representation.

THE MANUFACTURER WILL NOT BE LIABLE FOR ANY DAMAGE RESULTING FROM THIS APPLIANCE BEING INSTALLED BY A NON-CERTIFIED/FACORY TRAINED INSTALLER

Some states do not allow the exclusion or limitation of consequential damages, or limitations of implied warranties, so the limitations or exclusions set forth in this warranty may not apply to you. This warranty gives you specific legal rights and you may also have other rights, which vary, from state to state.

Warranty/replacement parts must be handled through the dealer that sold you your appliance.

ALL CLAIMS NOT HANDLED THROUGH YOUR LOCAL DEALER UNDER THIS WARRANTY MUST BE MADE IN WRITING TO THE MANUFACTURER AT: AMERICAN ENERGY SYSTEMS, INC.

150 Michigan Street SE, Hutchinson, Minnesota 55350; **Technical Support telephone number 320-234-0743**

Included with the claim needs to be the following:

Name, address and telephone number of local reseller or representative, installer of product, original purchaser.

Date of purchase along with the model and serial number of the unit.

Nature of defect and procedures of what has been done to correct the problem. **(unit must be checked out by the dealer that sold you the unit before submitting warranty replacement parts.)**

