

OUTDOOR FIREPLACE MANUAL

MODELS: OFP42N, OFP42NE, OFP42NE2, OFP42LP, OFP42LPE, OFP42LPE2, OFP42NS, OFP42NSE, OFP42NSE2, OFP42LPS, OFP42LPSE, OFP42LPSE2
CERTIFIED FOR USA & CANADA- ANSI Z21.97-2017 • CSA 2.41-2017 -
OUTDOOR DECORATIVE GAS APPLIANCES



OFP42
OUTDOOR FIREPLACE

INSTALLER: Leave this manual with the appliance.

CONSUMER: Retain this manual for future reference.

DANGER



CARBON MONOXIDE HAZARD

This appliance can produce carbon monoxide which has no odor.

Using it in an enclosed space can kill you.

Never use this appliance in an enclosed space such as a camper, tent, car or home.

This appliance is designed as an “attended appliance”. Adults must be present when the unit is operating. DO NOT leave this unit burning when unattended. If this product is left burning unattended it may cause damage or serious injury.

DANGER

FIRE OR EXPLOSION HAZARD

If you smell gas:

- Shut off gas to the appliance.
- Extinguish any open flame.
- If odor continues, leave the area immediately.
- After leaving the area, call your gas supplier or fire department.

Failure to follow these instructions could result in fire or explosion, which could cause property damage, personal injury, or death.

WARNING

Do not store or use gasoline or other flammable vapors and liquids in the vicinity of this or any other appliance.

An LP-cylinder not connected for use shall not be stored in the vicinity of this or any other appliance.

WARNING

For Outdoor Use Only.

Installation and service must be performed by a qualified installer, service agency, or the gas supplier.

WARNING

If the information in this manual is not followed exactly, a fire or explosion may result causing property damage, personal injury, or loss of life.

Warnings, Installations and Operations

WARNING

FOR SAFE INSTALLATION AND OPERATION OF YOUR GAS FIREPLACE PLEASE NOTE THE FOLLOWING:

1. when an appliance is for connection to a fixed piping system, the installation must conform with local codes or, in the absence of local codes, with the National Fuel Gas Code, ANSI Z223.1 • NFPA 54; National Fuel Gas Code; Natural Gas and Propane Installation Code, CSA B149.1; or Propane Storage and Handling Code, CSA B149.2, as applicable.
2. This appliance, when installed, must be electrically grounded in accordance with local codes or, in the absence of local codes, with the National Electrical Code, ANSI/NFPA 70; or the Canadian Electrical Code, CSA C22.1, if applicable.
3. THIS UNIT IS NOT FOR USE WITH SOLID FUEL.
4. Always keep the appliance clear and free from combustible materials, gasoline, and other flammable vapors and liquids.
5. Inspect the fuel supply connection (including the hose for LP models) before each use of the appliance. See Lighting Instructions for removal of Access Panel.
6. If it is evident there is excessive abrasion or wear, or the hose is damaged, it must be replaced prior to the appliance being put into operation. Locate the hose out of pathways where people may trip over it or in areas where the hose may be subject to accidental damage
7. Locate the hose out of pathways where people may trip over it or in areas where the hose may be subject to accidental damage.
8. Children and adults should be alerted to the hazards of the high surface temperatures of this appliance and should stay away to avoid burns or ignition of clothing.
9. Young children should be carefully supervised when they are in the area of the appliance.
10. Clothing or other flammable material should not be placed on or near the appliance. This appliance should not be used as a drying rack for clothing.
11. Any safety screen or guard removed for servicing an appliance must be replaced prior to operating the appliance.
12. Installation and repair should be done by a qualified service person. The appliance should be inspected before use and at least annually by a professional service person. More frequent cleaning may be required due to excessive lint from carpeting, et cetera. It is imperative that control compartments, burners and circulating air passageways of the appliance be kept clean.
13. Do not use this appliance if any part has been under water. Immediately call a qualified service technician to inspect the unit and to replace any part of the control system and any gas control which has been underwater.

LP Cylinder Requirements

The LP gas supply cylinder used with LP models must be constructed and marked in accordance with the specifications for LP-gas cylinders of the U.S. Department of Transportation (DOT) *Specifications for LP-Gas Cylinders, or the Standard for Cylinders, Spheres and Tubes for Transportation of Dangerous Goods and Commission*, CAN/CSA-B339, as applicable.

- The LP gas supply cylinder used with LP models must be provided with a listed overfilling prevention device.
- The pressure regulator and hose assembly supplied with LP models (PN# **27FP-900FF**) must be used.
- Replacement pressure regulators and hose assemblies must be those specified in this manual.
- Always check for gas leaks with a soap and water solution. DO NOT USE OPEN FLAME FOR LEAK TESTING.
- When an LP model is not in use, the LP-gas must be turned off at the supply cylinder.
- At altitudes above 4500ft appliances should be derated 4% every 1000ft. However, check with local gas supplier as fuel supply may already be adjusted.
- Refer to Assembly and Installation for leak testing procedures.
- Refer to Gas Specifications for gas inlet pressures.
- Refer to Gas Specifications for input rates.
- Refer to Lighting Instructions for normal sequence of the ignition system.

For an appliance designed for use with a non-disposable self-contained LP-gas supply system:

- Propane cylinders may be acceptable for use with the appliance provided they are compatible with the appliance retention means.
- LP-gas supply cylinder must be constructed and marked in accordance with the *U.S. Department of Transportation (D.O.T.) Specifications for LP-Gas Cylinders, or the Standard for Cylinders, Spheres and Tubes for Transportation of Dangerous Goods and Commission*, CAN/CSA-B339 as applicable.
- LP-gas supply cylinders between 4 and 40 pounds must have an overfill prevention device.
- LP-gas supply cylinder must have a connection device compatible with the connection of the appliance.
- If the appliance is equipped with a CGA No. 600 Cylinder Connection Device, the cylinder must be disconnected when the appliance is not in use.
- If appliance is to be permanently connected to a gas piping system from a remote supply tank, installation must be in accordance with local codes or, in the absence of local codes, with the *National Fuel Gas Codes ANSI Z223.1/NFPA 54*.

OFP42 Table of Contents

Cover.....	1
Warnings, Installations and Operations.....	2
LP Cylinder Requirements.....	2
Table of Contents.....	3
Locating Your Appliance.....	4
Clearance Specifications.....	5
INSTALLATION	
Pre-installation Questions and Answers.....	6
Important Information About Outdoor Fireplaces.....	6
Framing Specifications.....	7
Installation Clearances.....	8
Gas Line Installation.....	9
Gas Specifications.....	9
Enclosures for LP (Propane) Gas Supply Systems.....	10
ACCESSORIES	
Installing Brick Panels.....	11
Installing Curtain and Hood.....	11
Stainless Steel Surround.....	12
Log F37.....	13
MQROCK.....	14
MQG10 (W-B) and MQROCK Setup.....	15
Weather Cover.....	16
Electronic Spark Assist.....	17
GENERAL USE AND MAINTENANCE	
Component Locations.....	18
Lighting Instructions - Millivolt.....	19
Burner System Maintenance.....	20
Gas Conversion Part A.....	20-21
Gas Conversion – Pilot – Part B – Millivolt.....	21
Gas Conversion for Top Convertible Pilot – Part B – IPI.....	22
Gas Conversion for Modulator – PART C.....	23
IPI PROFLAME 1	
Lighting Instructions - Intermittent Pilot Ignition System (IPI).....	24
IPI Electronic Ignition System.....	25
IPI Proflame 1 Parts List.....	26
Operating the Receiver Without Batteries For GT / EGT / GTM / EGTM Remote Controls.....	27
Remote Control Operation – IPI Proflame 1.....	28
IPI PROFLAME 2	
IPI Proflame 2 IFC Module and Remote Control.....	29
IPI Proflame 2 Parts List.....	30
IPI Proflame 2 Schematic.....	31
TROUBLESHOOTING & CLEANING	
Troubleshooting the Gas Control System.....	32
Cleaning.....	32
PARTS LIST	
Parts List.....	33-34
WARRANTY	
Limited Warranty.....	35

Locating Your Appliance

Note: Ventilation and air flow comes from openings in the walls and ceiling. Open floor space around the appliance must not be considered ventilation and air flow space.

- This unit requires combustion air and will produce exhaust gases. Install in an open-air situation with natural ventilation and without stagnant areas.
- Avoid installing in tight spaces and corners.
- Be aware of combustibles (i.e. furniture) near appliance.
- By definition, an outdoor space is not enclosed. Any area in which these appliances are used shall comply with the structures shown below.

Locating Your Appliance – Outdoor Spaces

This appliance may be installed within the following structures:

1.

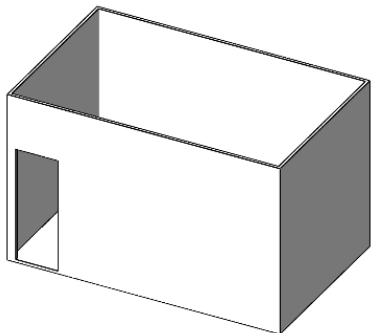

Walls on all sides (Minimum area of 96 square feet), but with no overhead cover and at least one permanent opening (doorway) at ground level.

2. **MUST HAVE 2 SIDES OPEN.**

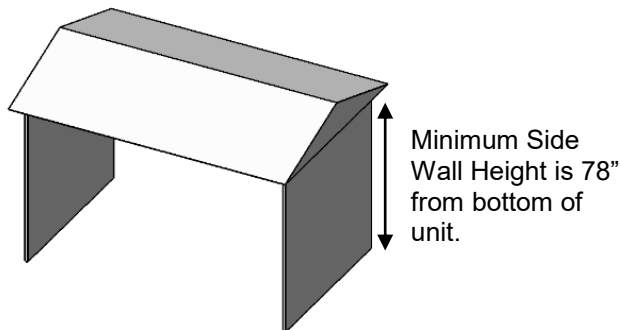

Within a partial enclosure that includes an overhead cover and no more than two side walls.

3. **MUST HAVE 2 SIDES OPEN.**

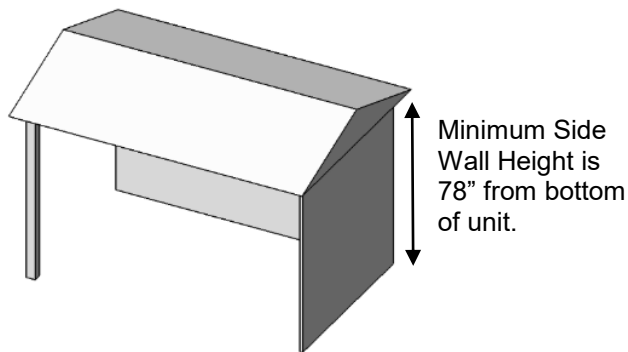

These side walls may be parallel, as in a breezeway, or at right angles to each other.

4.

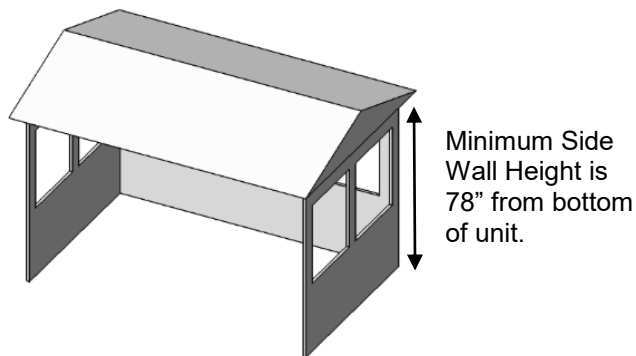

Within a partial enclosure that includes an overhead cover and three side walls, as long as **30 percent** or more of the horizontal periphery of the enclosure is permanently open.

- Screened Porch Installation -

OFP42 Series outdoor fireplaces can be installed safely in a screened porch area within the following guidelines:

Minimum porch area..... 96sq. feet

Minimum ceiling height92" inches

A minimum of two (2) walls can be screened, but must be open to outside ventilation, with a minimum screen area of 64 sq. feet, and a minimum side wall height of 78" inches.

⚠ WARNING –RISK OF FIRE-

ALL MINIMUM CLEARANCES MUST BE ADHERED TO

Clearance Specifications 420FP

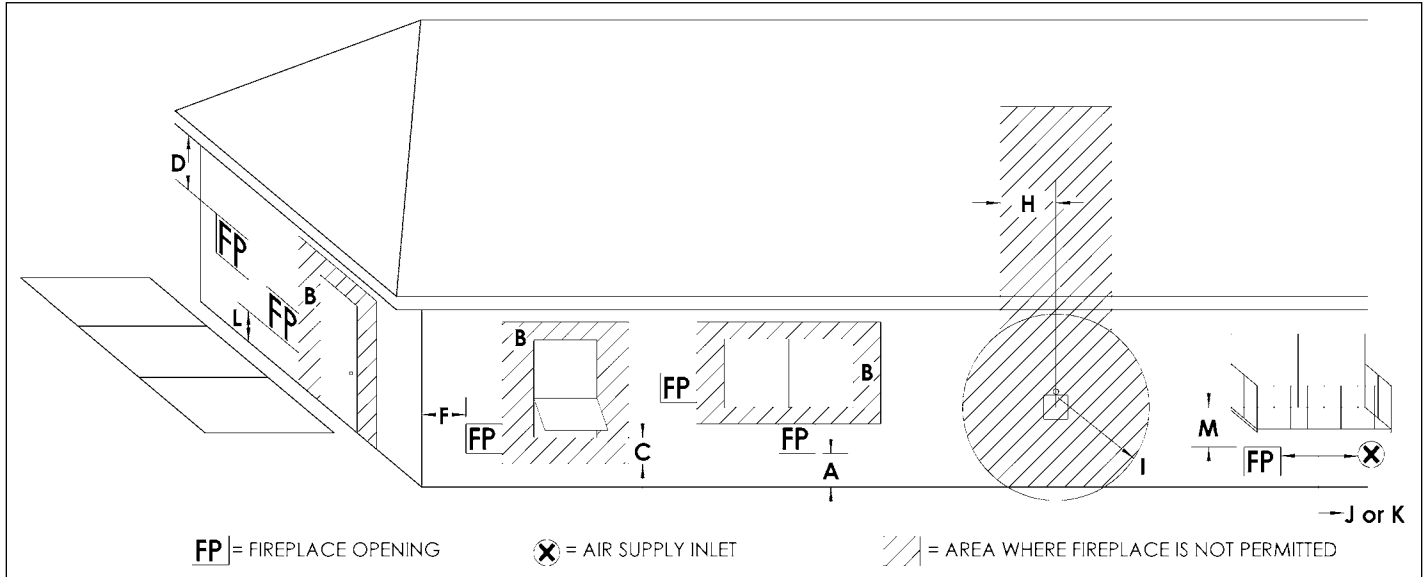

A = 2in.....	Clearances above grade, veranda, porch, deck or balcony.	I = 3ft (USA).....	Clearance to service regulator vent outlet and electric service.
B = 12in.....	Clearances to window or door that may be opened, or to permanently closed window.	J = 9in (USA).....	Clearance to non-mechanical air supply inlet to building or the combustion air inlet to any other appliance.
36in.....	Vinyl windows or siding.	12in (Canada)	
C = 12in.....	Clearance below an operable window.	K = 3ft (USA).....	Clearance to a mechanical air supply inlet
D = 47in.....	Vertical clearance to unventilated soffit or to or to ventilated soffit located above the fireplace.	6ft (Canada)	
60in.....	Vinyl clad soffits.	L* = 54in.....	Clearance above paved sidewalk or a paved driveway located on public property.
G = 3-1/2in.....	Clearance to inside corner.	(See note 1)	
48in.....	Vinyl windows or siding.	M** = 47in.....	Clearance under veranda, porch, deck, balcony or overhang.
H = 3ft. (Canada)	Not to be installed above a gas meter/regulator assembly within 3ft horizontally from the center line of the regulator.	Not allowed....	Vinyl.

Minimum Floor to Ceiling Height is 85 inches.

NOTE: Diagrams & Illustrations not to scale.

* A fireplace shall not open directly above a sidewalk or paved driveway which is located between two single family dwellings and services both dwellings.

**Only permitted if veranda, porch, deck or balcony is fully open on a minimum of 2 sides beneath the floor, or if the screened porch guidelines are followed.

Note 1: Local codes or regulations may require different clearances.

The OFP42N and OFP42LP can be installed safely in a screened porch area within the following guidelines:

Minimum porch area..... 96sq. feet
Minimum ceiling height92" inches

A minimum of two (2) walls can be screened, but must be open to outside ventilation, with a minimum screen area of 64 sq. feet, and a minimum side wall height of 78" inches.

Note: There may be some odor and small amounts of soot associated with burning the fireplace in a screened porch. Ensuring good cross draft ventilation and routine maintenance of the fireplace will maximize comfort and cleanliness.

Note: This appliance must not be installed inside or through an exterior wall.

Note: This appliance may be installed against the outside of an exterior wall provided that all clearance requirements have been met.

Pre-installation Questions and Answers

About curing of the paint

Your stove or fireplace has been painted with the highest quality silicone stove paint. This paint dries quickly in 15-20 minutes when first applied at the factory. However, due to the high temperature silicone components, the paint will cure when heat is applied to the appliance as it is first used. The following information applies to the curing process to get the paint fully hard and durable.

Fire the appliance four successive times for 10 minutes each firing and a 5 minute cool down between each.

- Babies, small children, pregnant women and pets should leave the area during the cure phase.
- Do not touch during curing.

Why does my fireplace or stove give off odour?

It is normal for your fireplace to give off some odor at first. This is due to the curing of the paint, adhesives, silicones and any undetected oil from the manufacturing process as well as the finishing materials used with the installations (e.g. marble, tile and the adhesives used to adhere this product to the walls can react with heat and cause odours).

These odours can last upward to 40 hours of burn time.

Noise coming from the fireplace?

Noise is caused by the expansion and contraction of metal as the appliance heats up and cools down. This is normal and is similar to the sounds produced by a furnace or heating duct. This noise does not affect the operation or longevity of your fireplace.

Note to the Installer:

Be sure appliance is working properly and its operation (including remote control operation, if included) is fully explained to and understood by the customer.

-Operating Instructions-

1. Be sure to read and understand all the instructions in this manual before operation of appliance.
2. Ensure all wiring is correct and properly enclosed to prevent possible shock.
3. Check for gas leaks.
4. If the unit is turned off, you must wait a minimum of 60 seconds before re-lighting it.

Important Information About Outdoor Fireplaces

Before you build in this appliance:

- Do not insulate around the appliance. Heat buildup could lead to component failure.
- Pay attention to all clearances to combustibles and specifications stated in this manual.
- Drainage- If this appliance is installed in a location where it will be exposed to water and moisture, drainage is an important consideration.
- Inadequate drainage will cause rust, which is not covered by the warranty.

Information about outdoor fireplaces

- Outdoor fire burning appliances may not function properly at all times regardless of the circumstances.
- Wind can greatly affect flame performance. If used in windy conditions a wind guard is recommended.
- Outdoor units require adequate ventilation in order to burn properly.
- Restricted access to air is not only dangerous for persons near the appliance, but the appliance also will not function correctly.
- This appliance consumes air, burns fuel, and emits heat and exhaust gases.
- Only approved media and accessories listed in this manual should be used with this appliance.
- This appliance is not intended for use in temperatures below freezing.
- The pilot burner (if equipped) should be OFF, and covered to protect it from the elements when not in use.

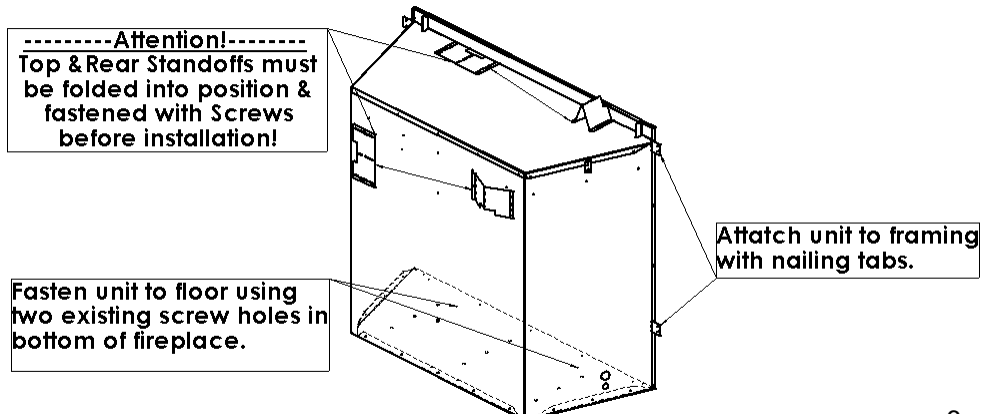

OFP42 - Framing Specifications

-Fireplace and Framing Dimensions-

*Attention: Top & Rear Standoffs must be folded into position & fastened with Screws before installation.

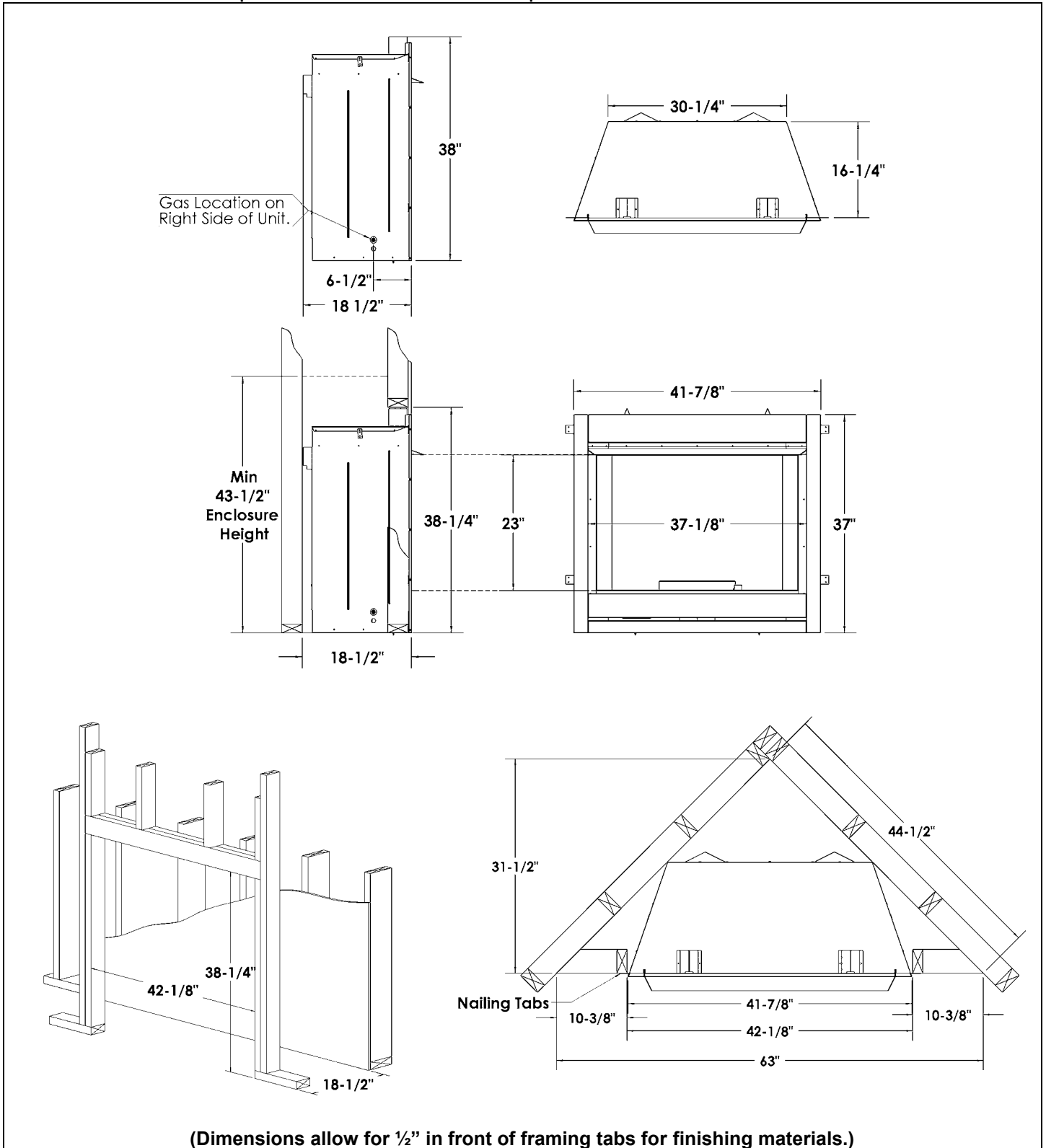

(Dimensions allow for 1/2" in front of framing tabs for finishing materials.)

Framing Clearances to Fireplace and Standoffs(Unless otherwise noted): Bottom: 0" / Sides: 0" / Adjacent side wall: 3-1/2" /Floor of fireplace to ceiling: 85" /Low Profile Enclosure: 43-1/2"Minimum. Back: 0" / Top: 0".

OFP42 - Installation Clearances

Carefully follow the instructions below. This will ensure safe installation.

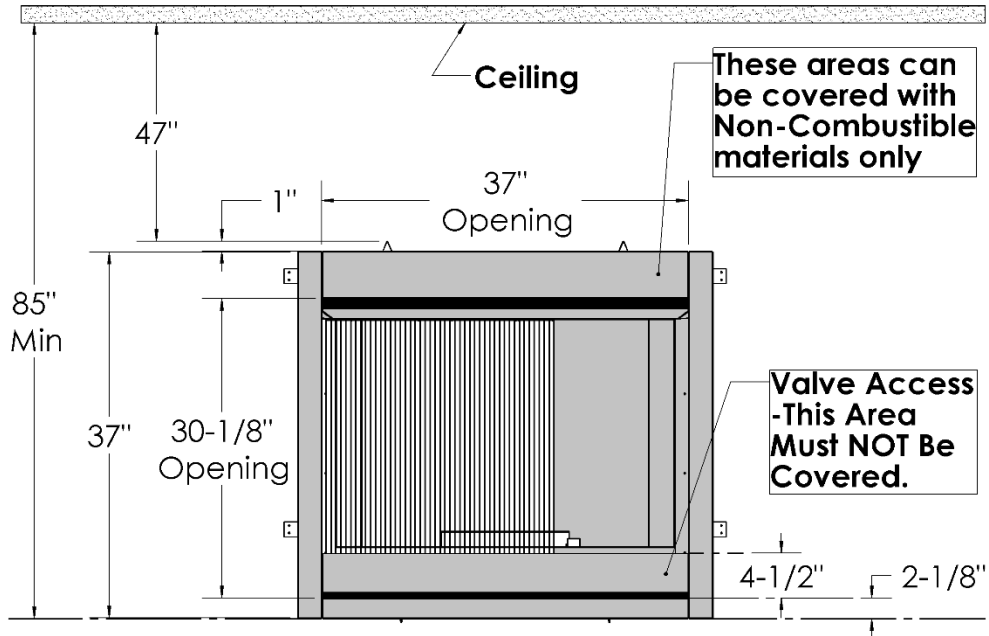

Clearances:

- Clearances from the firebox to adjacent wall should not be less than 3-1/2 inches.
- Clearance from the top of the fireplace front to the ceiling should not be less than 47 inches.
- Clearance from the bottom of the firebox to the floor is 0 inches.
- Clearance from the side of the fireplace to the enclosure is 0 inches.
- Clearance from the top of the fireplace standoffs is 0 inches.

Warning

- Improper installation, adjustment, alteration, service, or maintenance can cause injury or property damage. Read the installation, operating and maintenance instructions thoroughly before installing or servicing this equipment.
- Ensure the minimum clearances shown are maintained. Left and right clearances are determined when facing the front of the unit.
- Maintain the minimum clearances. If you can, provide greater clearances from the floor, ceiling, and adjoining wall.

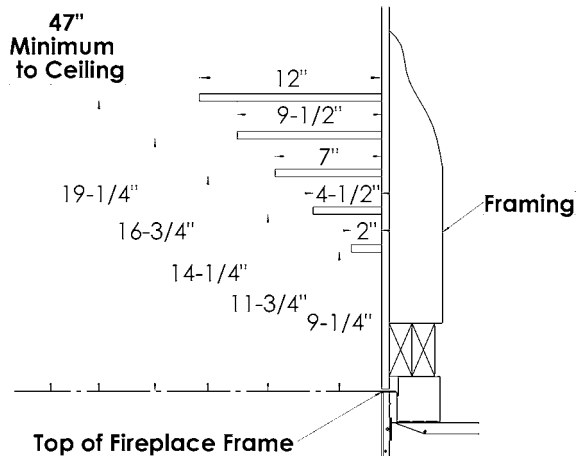

Mantel Clearances

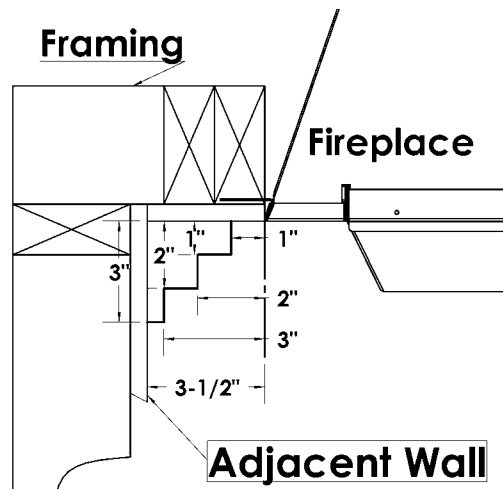

Mantel Clearances- Side Walls

Notice: A qualified service person must install firebox. Follow all local codes.

OFP42 - Gas Line Installation

This gas appliance should be installed by a qualified installer in accordance with local building codes and with current CAN/CGA - B149.1 or .2 installation codes for Gas Burning appliances and equipment in Canada and the National Fuel Gas Code ANSI Z223 in the U.S.A.

1. The gas pipeline can be brought in through either the left side or the bottom of the appliance. A knockout is provided at either location to allow for the gas pipe installation and testing of any gas connection.
2. The gas control inlet is 3/8" NPT. Typical installation layout for rigid pipe is shown at right.
3. When using copper or flex connector, use only approved fittings. Always provide a union so that gas line can be easily disconnected for burner or fan servicing. See gas specification for pressure details and ratings.
4. When a vertical section of gas pipe is required for the installation, a condensation trap is needed. See CAN/CGA-B149.1 or .2 for code details.
5. For natural gas, a minimum of 1/2" iron pipe with gas minimum pressure of 5.5" w.c. must be used for supply from the gas meter. Consult with the local gas utility if any questions arise concerning pipe sizes.
6. Ports are accessible for test gauge connection both on the inlet and outlet of the gas valve.
7. Turn the gas supply ON and check for leaks. **DO NOT USE OPEN FLAME FOR THIS PURPOSE.** Use an approved leak testing solution.
8. The appliance and its individual shutoff valve must be disconnected from the gas supply piping system during any pressure testing of that system at test pressures in excess of 1/2psig [3.5 KPa].
9. The appliance must be isolated from the gas supply piping system by closing its individual shutoff valve during any pressure testing of the gas supply piping system at test pressures equal to or less than 1/2psig [3.5 KPa].

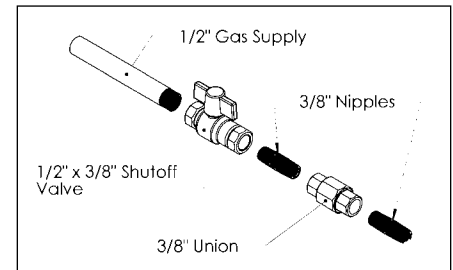

Note: The gas line connection may be made of 1/2" rigid pipe, 1/2" copper pipe or an approved flex connector. Since some municipalities have additional local codes, it is always best to consult your local authorities and the current CAN/CGA - B149.1 or .2 installation code in Canada or the National Fuel Gas code ANSI Z223.1 in the U.S.A.

For the state of Massachusetts a T-handle gas shut-off valve must be used on a gas appliance. This T-handle gas shut-off valve must be listed and approved by the state of Massachusetts. This is in reference to the state of Massachusetts state code CMR238.

IMPORTANT: Always check for gas leaks with a soap and water solution. **DO NOT USE OPEN FLAME FOR LEAK TESTING.**

-Gas Specifications-			
Models	OFP42N / OFP42NE / OFP42NE2 / OFP42NS / OFP42NSE / OFP42NSE2	OFP42LP / OFP42LPE / OFP42LPE2 / OFP42LPS / OFP42LPSE / OFP42LPSE2	
Fuel	Natural Gas	Propane	
Gas Control	Millivolt or IPI - HI/LO	Millivolt or IPI - HI/LO	
Maximum Input	38,000Lo / 55,000Hi	44,000Lo / 55,000Hi	
Orifice Size (0-4500ft)	#24	#42	
Air Shutter	1/4" Open	Fully Open	
Gas Inlet Size	S.I.T. 820 Nova, 3/8" NPT		
Gas Supply Pressure	Minimum	Normal	Maximum
Natural Gas	5.5"	7"	10"
Liquid Propane	11"	11"	13"
Manifold Pressure High	3.5" w.c. [0.87KPa] NG		10" w.c. [2.61KPa] LP
Manifold Pressure Low	1.6" w.c. [0.40KPa]		6.3" w.c. [1.57KPa]

Enclosures for LP (Propane) Gas Supply Systems

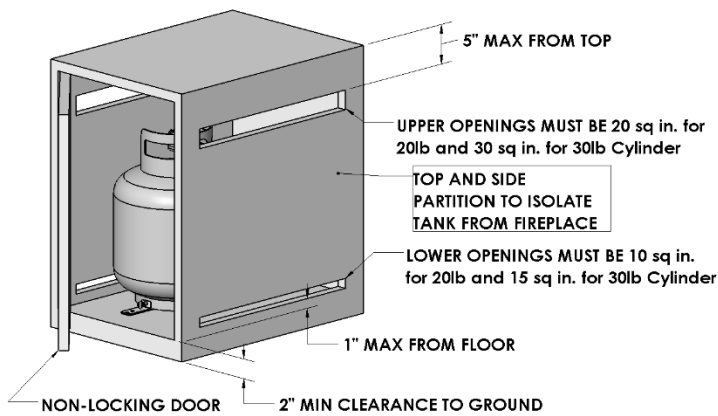

If you build an enclosure for an LP gas cylinder you must follow these specifications. You must also follow local codes.

An enclosure for an LP-gas cylinder shall be ventilated by openings at both the upper and lower levels of the enclosure. This shall be accompanied by one of the following:

- a. One side of the enclosure shall be completely open; or
- b. For an enclosure having four sides, a top, and a bottom:
 1. At least two ventilation openings shall be provided in the sidewalls of the enclosure, located within 5 in (217 mm) of the top of the enclosure, equally sized, spaced at a minimum of 90 degrees (1.57 rad), and unobstructed. The opening(s) shall have a total free area of not less than 1 square inch per pound (14.2 cm²/kg) of stored fuel capacity.
 2. Ventilation opening(s) shall be provided at floor level of the enclosure and shall have a total free area of not less than 1/2 square inches per pound (7.1 cm²/kg) of stored fuel capacity. If ventilation openings at floor level are in a sidewall, there shall be at least two openings. The bottom of the openings shall be 1 in (25.4 mm) or less from the floor level and the upper edge no more than 5 in (127 mm) above the floor level. The openings shall be equally sized, spaced at a minimum of 90 degrees (1.57 rad), and unobstructed.
 3. Every opening shall have minimum dimensions so as to permit the entrance of a 1/8 in (3.2 mm) diameter rod.
 4. Ventilation openings in sidewalls shall not communicate directly with other enclosures of the appliance.

The cylinder valve shall be readily accessible for hand operation. A door on the enclosure to gain access to the cylinder valves is acceptable, provided it is non-locking and can be opened without the use of tools. Designs using a cover to gain access to the cylinder and cylinder valve shall be provided with handles or equivalent at a minimum of 180 degrees apart to facilitate lifting of the cover.

The enclosure for the LP-gas cylinder shall isolate the cylinder from the burner compartment to provide:

- a. Shielding from radiation;
- b. A flame barrier; and
- c. Protection from foreign material.

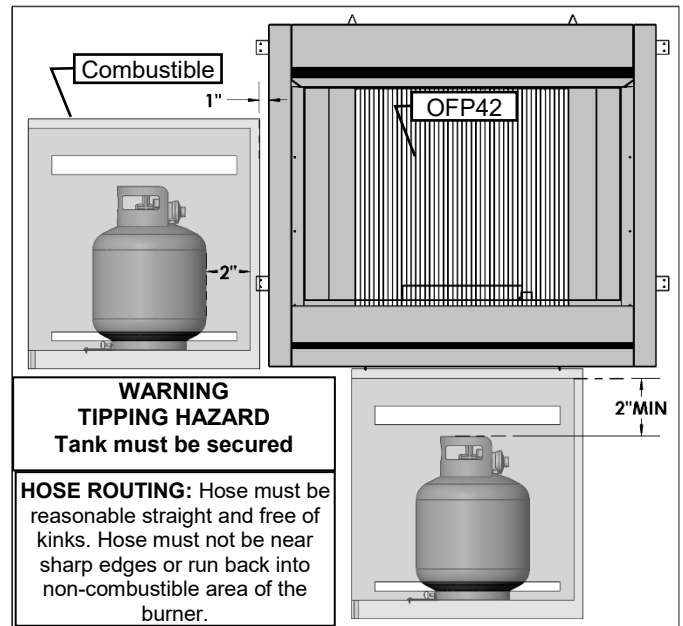

There shall be a minimum clearance of 2 in (50.8 mm) between the floor of the non-disposable LP-gas cylinder enclosure and the ground.

The design of the fireplace shall be such that:

- a. A non-disposable LP-gas cylinder can be connected, disconnected, and the connections inspected and tested outside the cylinder enclosure; and
- b. Those connections which could be disturbed when installing the cylinder in the enclosure can be leak tested inside the enclosure.

Be certain to mount or set the LP-gas cylinder on a flat stable surface and retain it to prevent it from tipping. Purge the gas supply line of any trapped air prior to the first firing of the unit.

WARNING: During the initial purging and subsequent lightings, NEVER allow gas valve to remain in "OPEN" position without first placing a burning match on the top of the burner.

Test fire the unit after referring to the SAFETY INFORMATION and LIGHTING INSTRUCTIONS.

If LP-Gas outdoor fire pits are used continuously after a couple of hours, you could see the possibility of the flame decreasing in size. If this happens, turn off the control valve and the tank valve and wait a couple of hours before lighting again or switch propane tanks. The propane tank is freezing up due to the volume of gas being taken out of the tank.



The above photo shows an example of an approved LP cylinder retention device.

OFP42 Installing Brick Panels

Installing Brick Panels

1. Remove Brick Clips and Screws from inside Firebox Top. Remove Log Support.
Do not discard these items.
2. Place Rear Brick Panel up against the back of the Firebox.
3. Tilt and slide Side Brick Panels into position in the sides of the Firebox. The Side Brick Panels should be against the face of the Rear Brick Panel, and behind the Inner Lip of the Firebox.
4. Re-insert the Brick Clips and Screws in the Firebox Top. Replace Log Support.

***Note:** Brick Panels can also be installed reversed, with the brick pattern against the firebox wall. This will give a dark, Textured Stone look to the inside of the firebox.

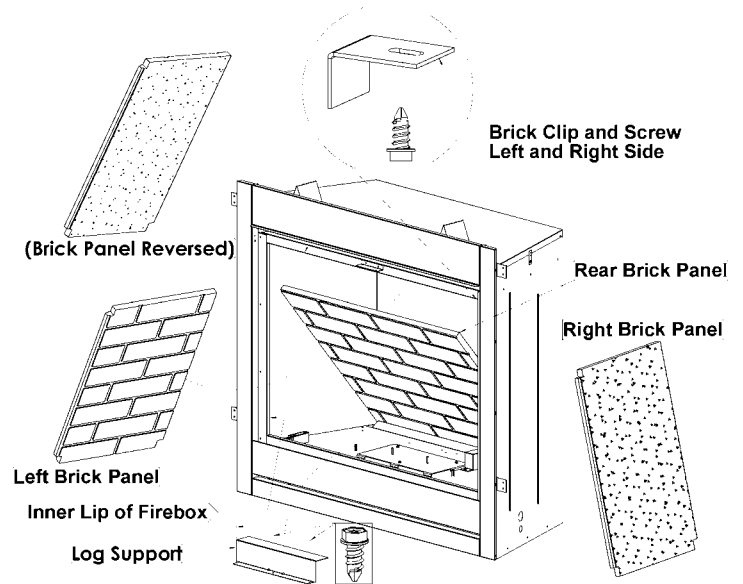

OFP42 Installing Curtain and Hood

Curtain

1. Slide curtain onto rod.
2. Slide rod into hole in Side Frame.
3. Slide rod into Rod Hanger Bracket.
4. Press on Pushnut.
5. Bend up Tab to lock rod & curtain into place.
6. Repeat for opposite side.

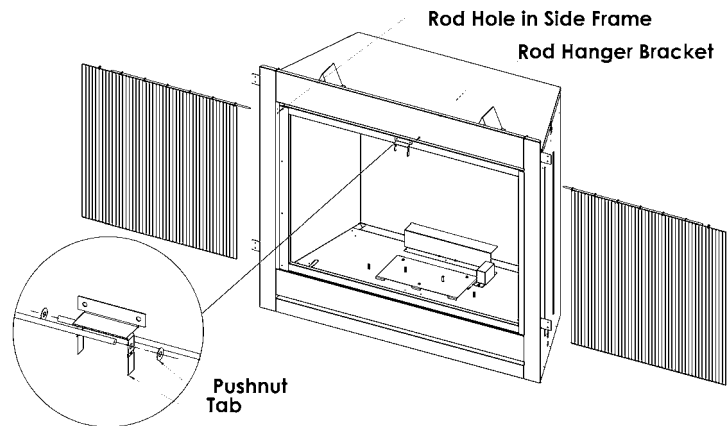

Hood

1. Remove DT Screws from inside top of Firebox.
2. Slide Hood Tabs into slots in Firebox top.
3. Re-insert DT screws through hood and into firebox top.

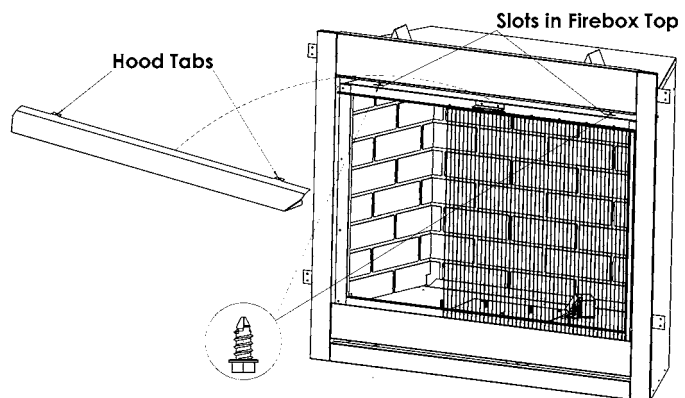

WARNING:

Failure to position the parts in accordance with these diagrams or failure to use only parts specifically approved with this appliance may result in property damage or personal injury.

OFP42SS - Optional Stainless Steel Surround

A Stainless Steel Surround is available as an option for the OFP42N/OFP42LP.
(Install before finishing with decorative material on facing of enclosure.)

OFP42SS Parts List

ITEM NO.	PART NUMBER	DESCRIPTION	Quantity
1	42OFP-108-SS	DEFLECTOR HOOD	1
2	42OFP-SS	Access Panel	1
3	42OFP-330-SS	Firebox Ledge Cap	1
4	42OFP-331-SS	Bottom Cover	1
5	42OFP-332-SS	SS Surround Left Side	1
6	42OFP-332R-SS	SS Surround Side Right	1
7	42OFP-333-SS	SS Surround Top	1
8	No. 6-.375-SML	#6 SS screw	5

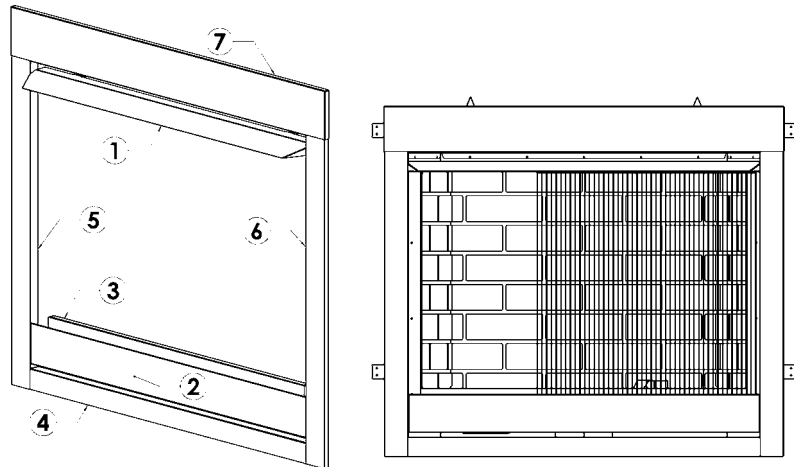

Part 1: Preparing the Fireplace

1. Remove the 2 DT Screws inside the Firebox Top and remove the Deflector Hood from the top of the unit.
2. Lift Access Panel and remove.

Set these 2 items aside as they will be replaced by parts of the Surround.

Remove Access Panel Brackets by removing DT Screws. **These Brackets will be reused with the Surround.**

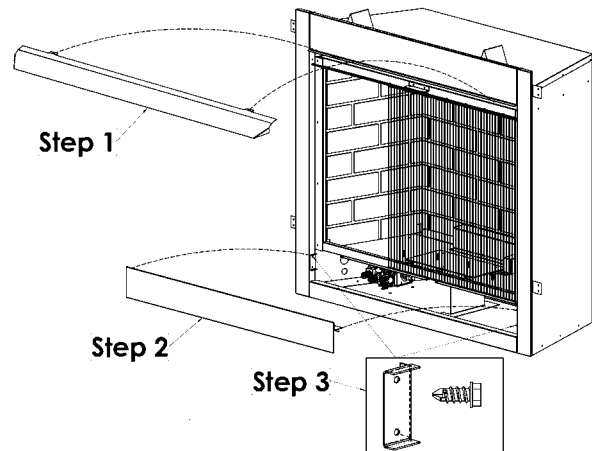

Part 2: Installing the Surround (See Surround Drawing above for reference.)

1. Place Firebox Ledge Cap (3) and Bottom Cover (4) into position on the Fireplace.
2. Slide Surround Top (7) onto Surround Sides (5&6). Place Surround Top and Sides onto fireplace.
3. Insert Screws into holes in the inside edge of the Surround Top, and into Sides just above the Curtain Rod.

Replace the Deflector Hood and Access Panel removed in Part 1 with the Stainless Steel Surround parts.

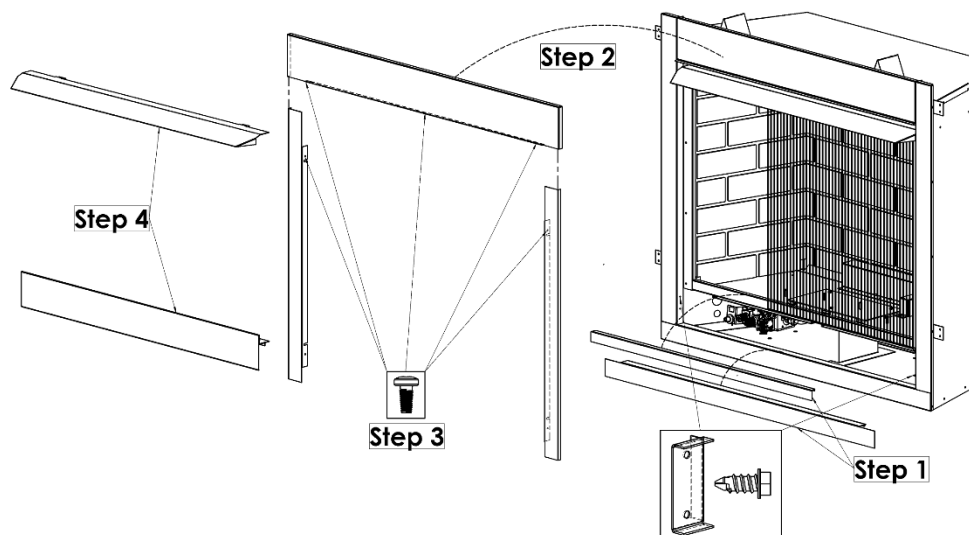

WARNING:

Failure to position the parts in accordance with these diagrams or failure to use only parts specifically approved with this appliance may result in property damage or personal injury.

Log F37 Installation for OFP42

- #1: 1 Bag of Small 1/4" Lava Rock - Supplied with Unit
- #2: 1 Bag of Large 3/4" Lava Rock – Supplied
- #3: LOGF37 – Outdoor 7 Piece Burnt Oak

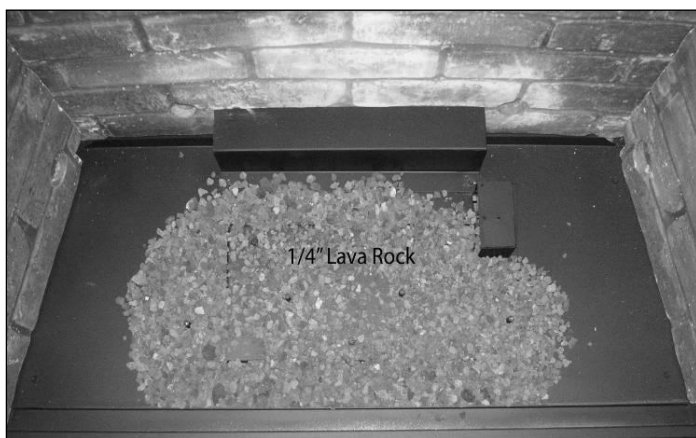
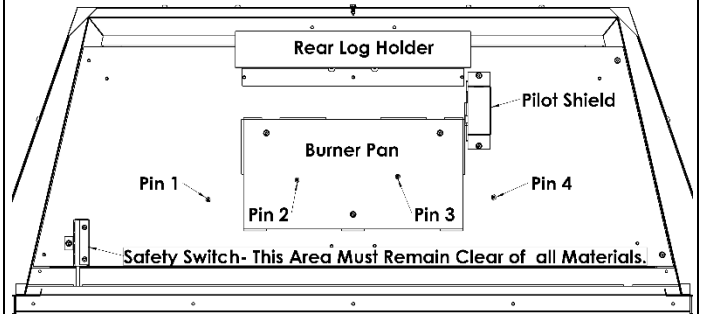
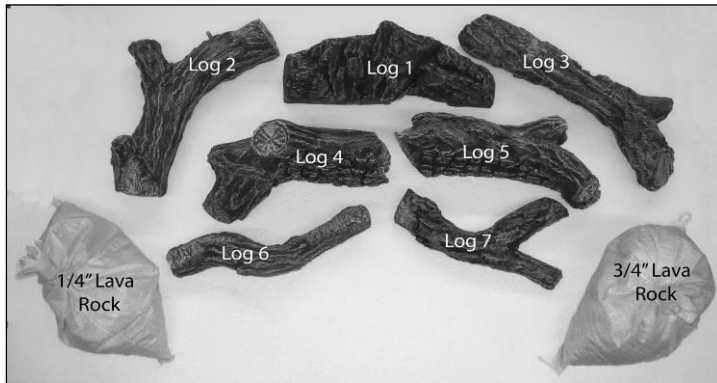

Step #1 – Place 1/4" Lava Rock onto and around outer Perimeter of the Pan Burner as shown. Leave the Log Placement Pins exposed.

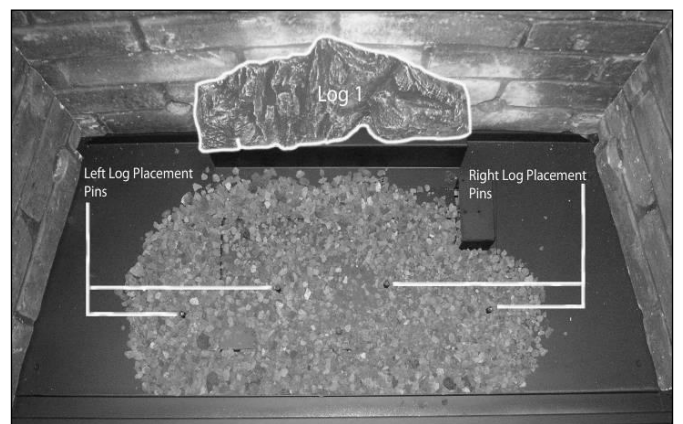

Step #2 – Place Log 1 onto Rear Log Holder and up to Brick Panel.

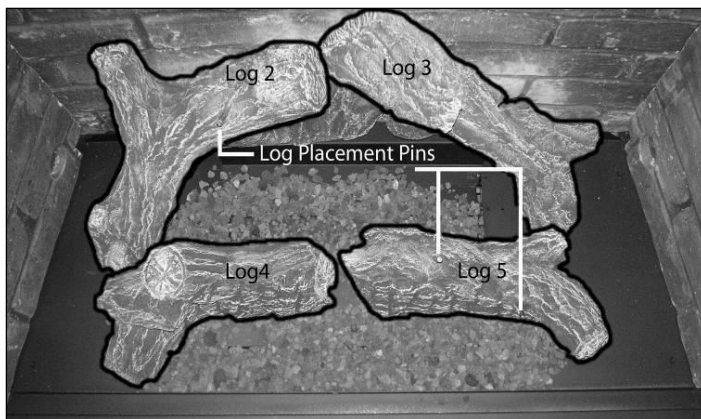

Step #3 – Place Logs 2-3 on top of Log 1, Locate holes On bottom of logs 4-5 and place these onto Log Placement Pins as shown in the Photograph above.

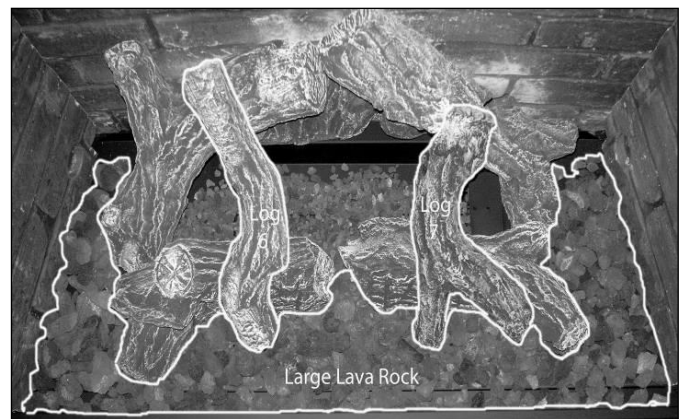

Step #4 – Locate holes on Logs 6-7 and place these onto Locating Pins of Logs 2-5, place Large Lava Rock around and in front of Log Set as shown.

MQROCK Setup for OFP42

Marquis (MQ) products are available through Marquis Dealers.

Parts List

#1: 1 Bag of Small 1/4" Lava Rock – Supplied with Unit

#2: MQROCK 2 or 3 – Box of 30 Rocks (MQROCK 3 shown below)

#3: MQG10W or MQG10B – Decorative Glass White or Black (Not Shown)

Do NOT use any materials other than those supplied or specified for this fireplace.

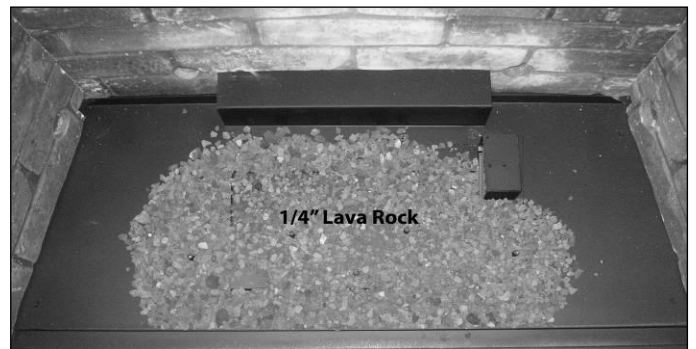
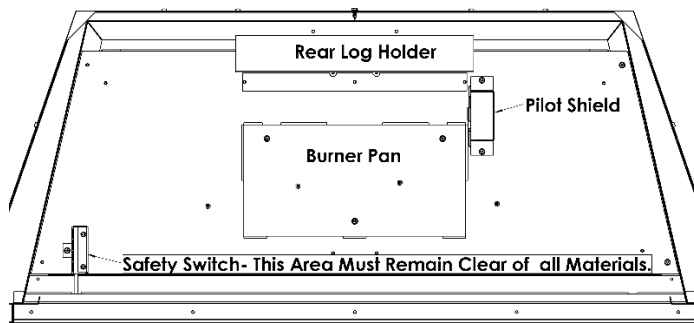
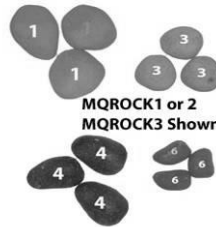

Step #1- Place 1/4" Lava Rock Onto and around Burner Pan as shown, Do Not place lava rock into pilot shield assembly area.

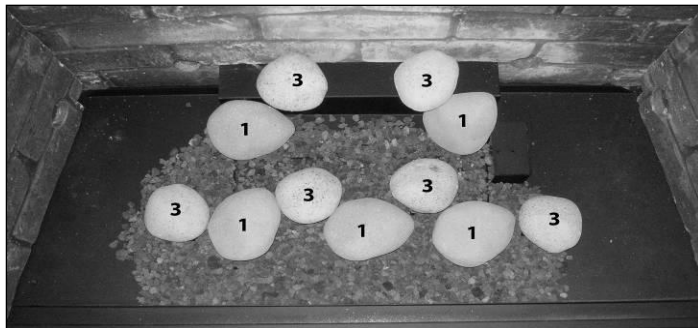

Step #2 – Suggested MQROCK Placement. Position rocks 1 and 3 as shown.

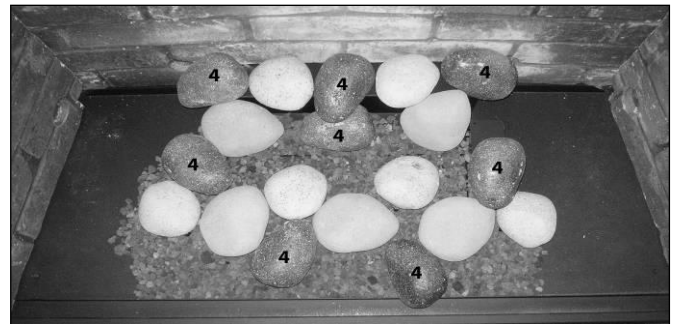

Step #3 – Position rock 4 as shown.

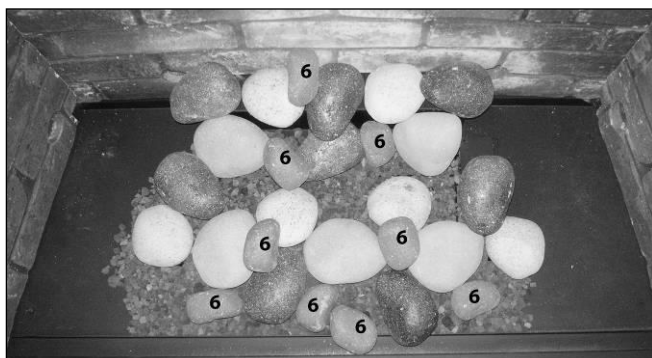

Step #4 – Position rock 6 as shown.

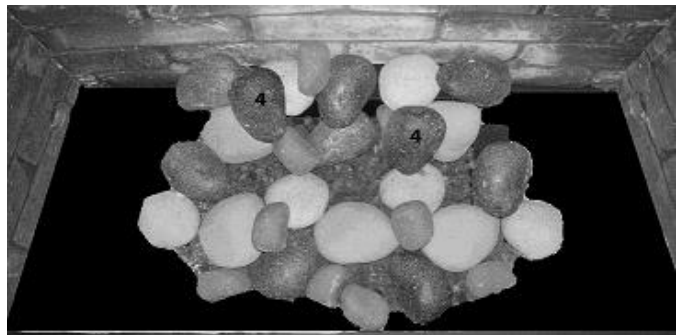

Step #5 – Position remaining rock 4 as shown.

MQG10 (W-B) and MQROCK Setup for OFP42

Marquis (MQ) products are available through Marquis Dealers.

Parts List

- #1: 1 Bag of Small 1/4" Lava Rock – Supplied with Unit (Not Used for this Set-up)
- #2: MQROCK 2 or 3 – Box of 30 Rocks (MQROCK3 shown below)
- #3: MQG10W or MQG10B – Decorative Glass White or Black

Do NOT use any materials other than those supplied or specified for this fireplace.

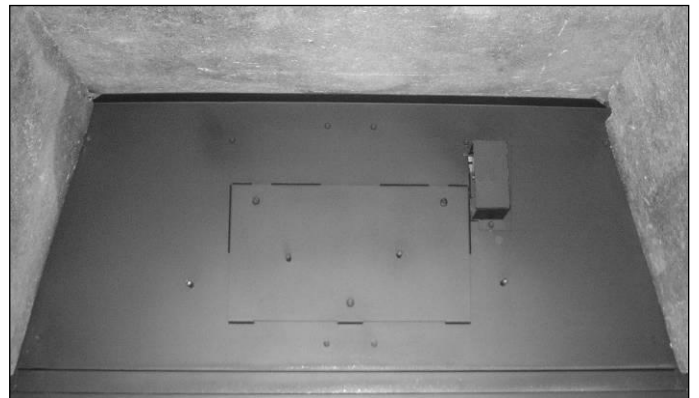
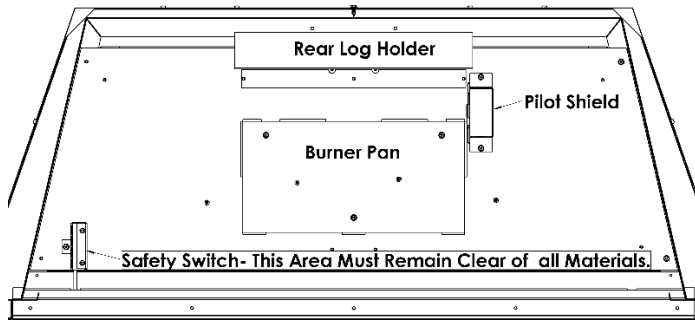

Step #1 – Remove Log Holder.

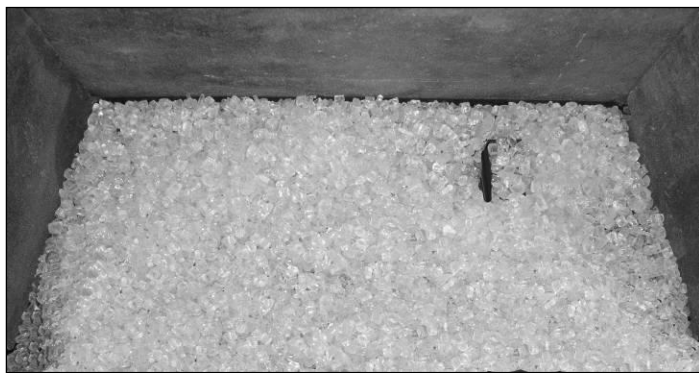

Step #2 – Place Glass onto and around Burner Pan as shown, do not place glass into the Pilot Shield assembly area. **NOTE: It is not necessary to place rocks over glass.**



Step #3 – Position Rocks as per MQROCK Set-up or position randomly as shown.

OFP42WC -Weather Cover-

An optional Weather Cover is available to protect the inside of the unit when not in use.

Assembly Instructions

1. Insert Carriage Bolts through handles and into front of Fireplace Cover.
2. Place [2] washers and nut onto bolts on the back side of the Fireplace Cover.
3. Tighten nuts with a 7/16" wrench.

Installation Instructions

1. Turn Valve Control Knob to the off position and wait until the fireplace is cool.
2. Move Curtains toward the center of the fireplace, allowing a 7½" space between curtains and frame sides (See **fig.1** below).
3. Slide the Weather Cover up behind the top lip of the firebox. Then Push the bottom of the Weather Cover into the firebox and allow it to drop into place (See **fig.2** below).

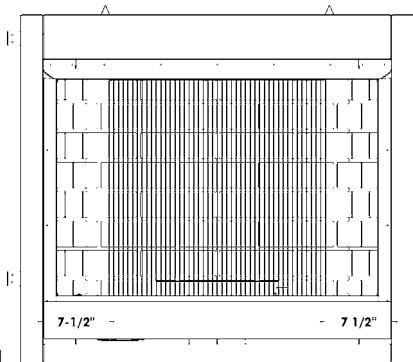
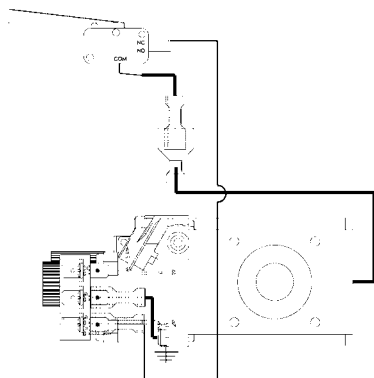

fig.1

Safety Switch- Wiring Diagram



Outdoor Fireplace Cover

ITEM NO.	PART NUMBER	DESCRIPTION	Default/QTY.
1	42OFP-114	Fireplace Cover	1
2	.250 SS CARIAGE BOLT		4
3	250-20 StainlessNut	1/4"-20 HEX NUT	4
4	42OFP-115	Handle	2
5	42OFP-133	Stainless Steel Washer	8

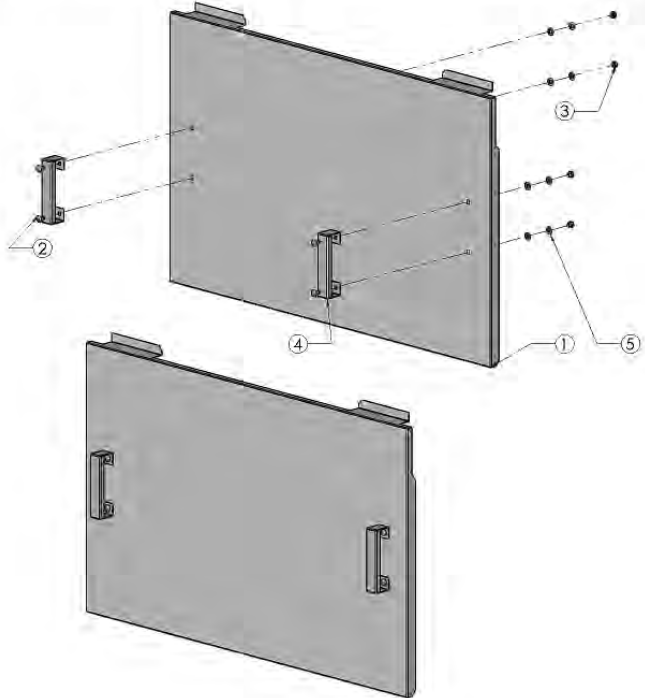

Cover Engages Safety Switch when Installed Properly.

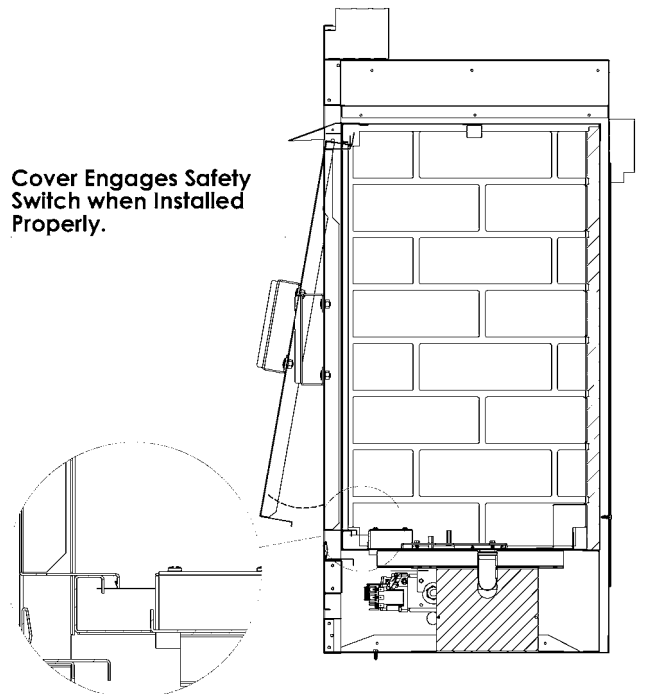
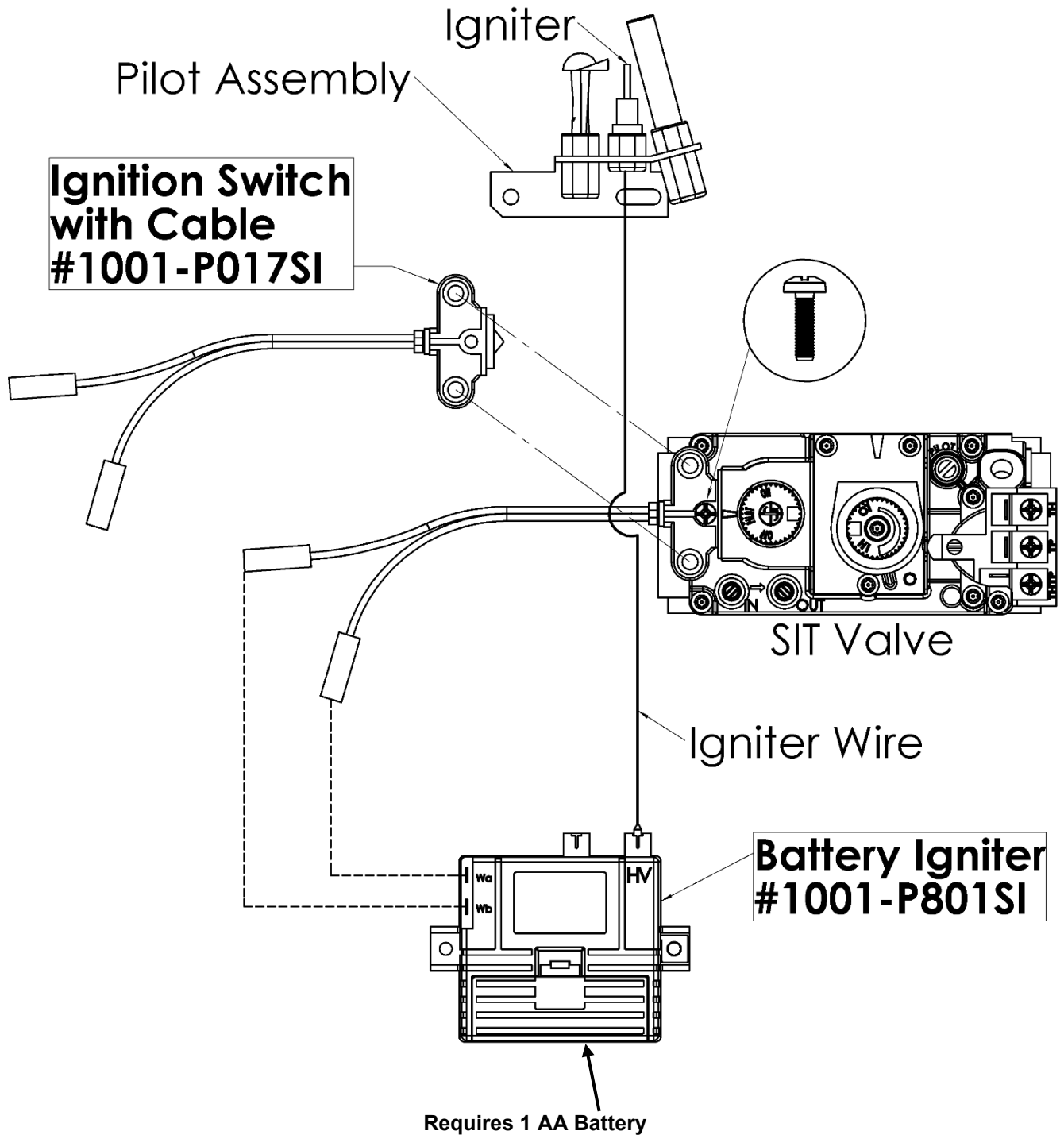

fig.2

OFP42 Electronic Spark Assist – Option for Millivolt System

Part Number #OFP42SA

A Battery powered module is available to assist in lighting the pilot burner. See below for installation.



Component Locations – OFP42

Millivolt System – Top View

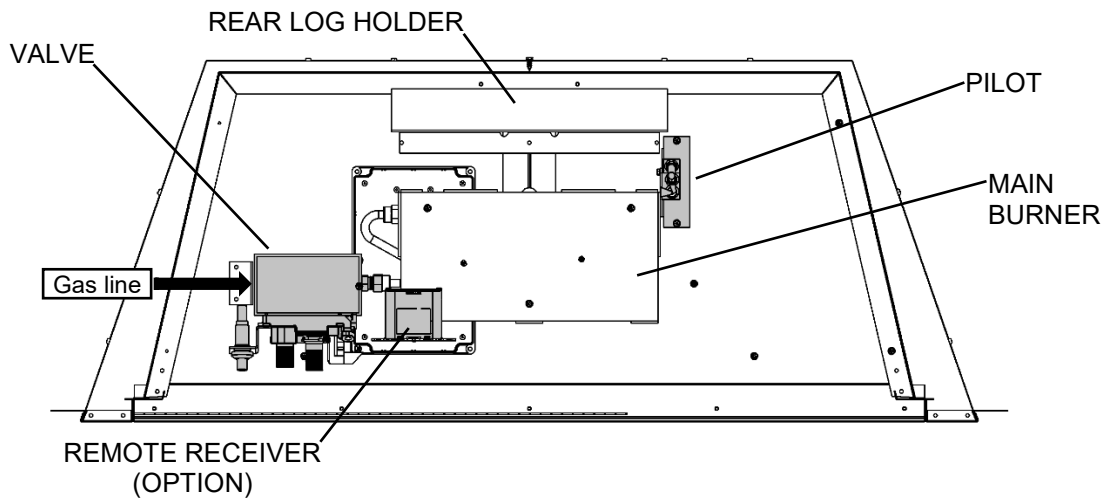

IPI Proflame 1 System – Top View

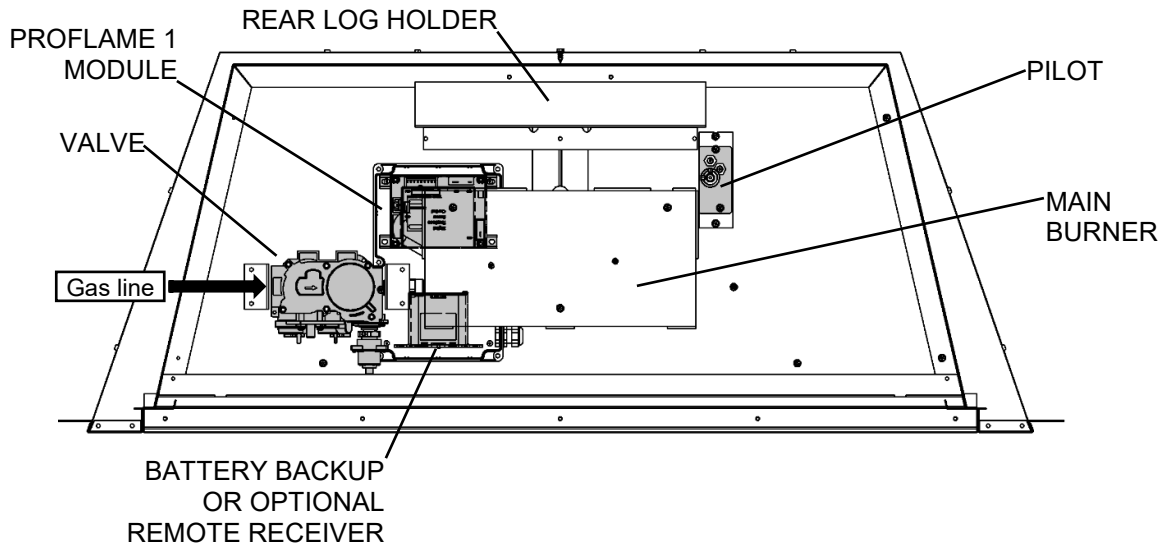

IPI Proflame 2 System – Top View

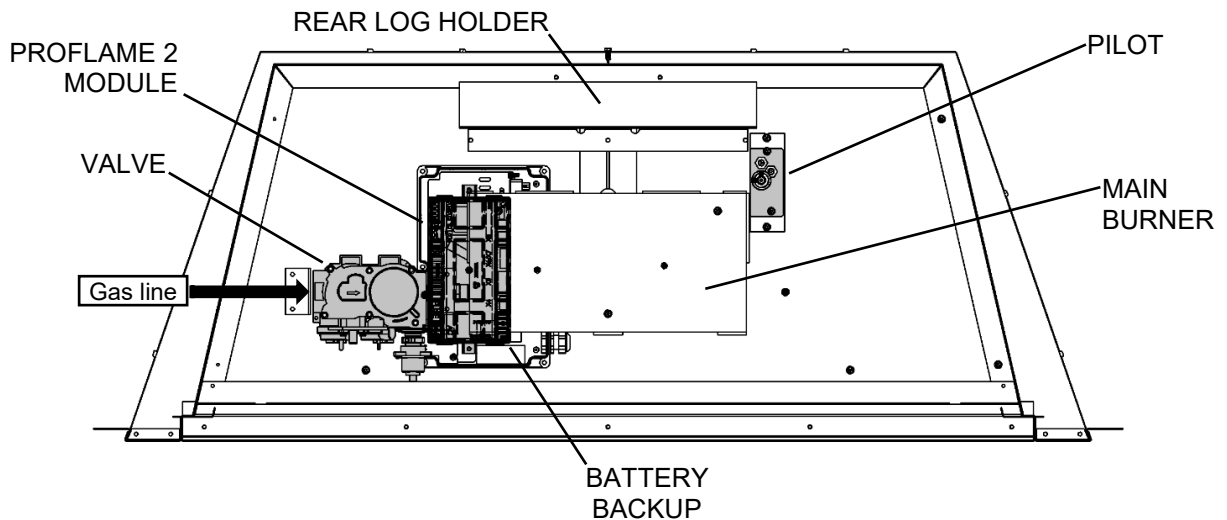

OFP42 Millivolt Lighting Instructions

1. Remove Front Panel in order to access Igniter and valve controls.

(To remove Access Panel, simply lift upward, and then pull forward.)

2. Refer to Millivolt Lighting Instructions below.

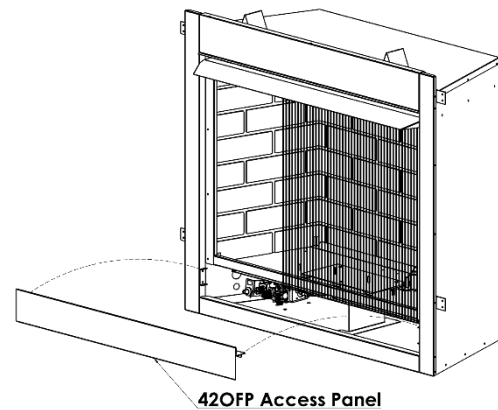

FOR YOUR SAFETY READ BEFORE LIGHTING

WARNING: If you do not follow these instructions exactly, a fire or explosion may result causing property damage, personal injury or loss of life.

BEFORE LIGHTING

- A This appliance has a pilot which must be lighted by hand. When lighting the pilot, follow these instructions exactly.
- B Smell all around the appliance area for gas. Be sure to smell next to the floor because some gas is heavier than air and will settle on the floor.
- WHAT TO DO IF YOU SMELL GAS
 - Do not try to light an appliance.
 - Do not touch any electrical switch; do not use any phone in your building.
 - Immediately call your gas supplier from a neighbour's phone. Follow the gas supplier's instructions.
- C Use only your hand to push or turn the gas control knob. Never use tools. If the knob will not push in or turn by hand, don't try to repair it, call a qualified technician. Force or attempted repair may result in a fire or explosion.
- D Do not use this appliance if any part has been under water. Immediately call a qualified service technician to inspect the appliance and to replace any part of the control system which has been under water.

LIGHTING INSTRUCTIONS

1. Stop! Read the safety information above on this label.
2. Set the thermostat to lowest setting.
3. Turn off all electrical power to the appliance.
4. Locate valve under the burner assembly.
5. If the control knob is not already in the off position, ie. the word "OFF" in the 9 o'clock position, then push in the gas control knob slightly and turn clockwise to "OFF".

NOTE: Knob cannot be turned from "PILOT" to "OFF" unless knob is pushed in slightly. Do not use force.
6. Wait five (5) minutes to clear out any gas. If you then smell gas. STOP! Follow "B" in the safety information above on this label. If you don't smell gas then go to the next step.
7. Now push in the control knob slightly and turn counter-clockwise to the "PILOT" position.
8. Push in the control knob all the way and hold it. With the other hand push in the red ignitor button until you hear a click. Now observe closely the pilot burner located on the rear center-left hand side of the main burner. If a flame has appeared then continue to depress the control knob for 20 seconds. If the flame did not appear then continue to depress the red ignitor button every 5 seconds until a flame is established. NOTE: If after 30 seconds a flame has not yet been established then turn the control knob back to the off position and repeat steps 5, 6 & 7.
9. Once the pilot has been established hold the control knob in the depressed position for approximately 25 seconds before releasing. If the flame goes out then repeat steps 7 and 8.
10. Now turn the control knob to the "ON" position. The burner will not light unless the wall switch thermostat or remote control is turned "ON" or in the case of the thermostat there is a call for heat.
11. Close the access door and turn all electric power back to the appliance.

TO TURN OFF THE APPLIANCE

1. Set the thermostat to lowest setting.
2. Turn off all electric power to the appliance if service is to be performed.
3. Open the control access door.
4. Push in the gas control knob slightly and turn clockwise to the "OFF" position. Do not force.
5. Replace control access panel.

Recommended Maximum Lead Length (Double Wire) When Using Wall Switch

Wire Size	Max. Length
14ga	100ft.
16ga	64ft.
18ga	40ft.
20ga	25ft.
22ga	16ft.

Pilot Burner Adjustment
Adjust pilot screw to provide proper sized flame.

Caution: Do not wire 120 Volt Power to millivolt switches or thermostat.

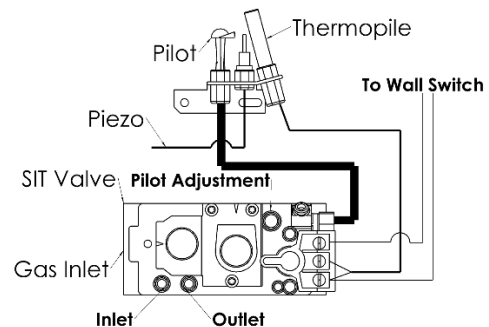

Burner System Maintenance

It is recommended to annually inspect and clean the Burner System to prevent malfunction and / or sooting. This operation should be performed by your dealer or a qualified technician.

! -CAUTION-

Before servicing the burner system ensure that the gas supply is turned OFF and disconnect all electrical connections to the appliance. Allow the appliance to cool to room temperature. Note that the pilot assembly may be hot—even if the main burner was never on. Exercise caution when working within the area.

-ALL WORK SHOULD BE PERFORMED BY A QUALIFIED AND CERTIFIED TECHNICIAN-

Monthly Flame Inspection

It is recommended to turn on the unit at least once a month and inspect the flame pattern to ensure there are no problems with the burner tube.



Flame should appear similar to above picture.

The pilot flame should also be inspected monthly to ensure proper operation.

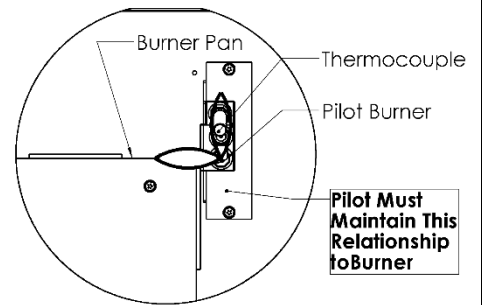

Pilot Shield area must be kept clear.

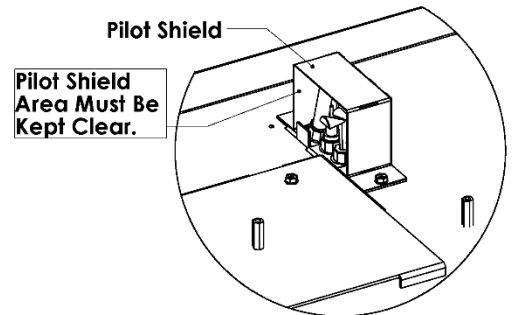

- Gas Conversion Part A -

Kit Number	Description	Pilot Orifice	Burner Orifice Brass (1000-255)	Brass Nipple	Air Shutter	Hi/Lo Regulator
42OFP-CKLP	Propane Conversion -Millivolt-	1001-P150SI #23	#42	1000-253closed	Fully Open	1001-P202SI (0.907.202)
42OFP-CKNG	NG Conversion -Millivolt-	1001-P132SI #37	#24	1000-253closed	1/4"	1001-P201SI (0.907.201)
42OFP-CKLPI	Propane Conversion -IPI-	1001-P168SI #35 (977.168)	#42	1000-253closed	Fully Open	1002-P014SI (0.907.014)
42OFP-CKNGI	NG Conversion -IPI-	1001-P166SI #62 (977.166)	#24	1000-253closed	1/4"	1002-P016SI (0.907.016)
42OFP-CKLP2	Propane Conversion -IPI P2-	1001-P168SI #35 (977.168)	#42	1000-253closed	Fully Open	1002-P012SI (907.012)
42OFP-CKNG2	NG Conversion -IPI P2-	1001-P166SI #62 (977.166)	#24	1000-253closed	1/4"	1002-P013SI (907.013)

Refer to "Gas Specifications Chart" for inlet pressures and input ratings. Clock meter to verify input rate. Place conversion label as close to converted gas control as possible. Refer to lighting instructions to verify the normal operating sequence of the ignition system.

IMPORTANT: Always check for gas leaks with a soap and water solution. DO NOT USE OPEN FLAME FOR LEAK TESTING

OFP42 Gas Conversion – Burner - Part A

⚠ Warning!

This conversion kit shall be installed by a qualified service agency in accordance with the manufacturer's instructions and all applicable codes and requirements of the authority having jurisdiction. If the information in these instructions is not followed exactly, a fire, explosion, or production of carbon monoxide may result in causing property damage, personal injury or loss of life. The qualified service agency is responsible for the proper installation of this kit. The installation is not proper and complete until the operation of the converted appliance is checked as specified in the manufacturer's instructions supplied with the kit.

-Burner Conversion-

1. Shut off and disconnect the gas supply to the appliance.
2. Remove Burner Pan Assembly from the Fireplace bottom by removing the screws in each corner of the firebox.
3. Invert Burner Pan.
4. Adjust Air Shutter opening to appropriate size: **NG ¼"Open – LP Fully Open.**
5. Remove existing Orifice and replace with new one: **NG #24 – LP #42.**
6. Replace Burner Pan.

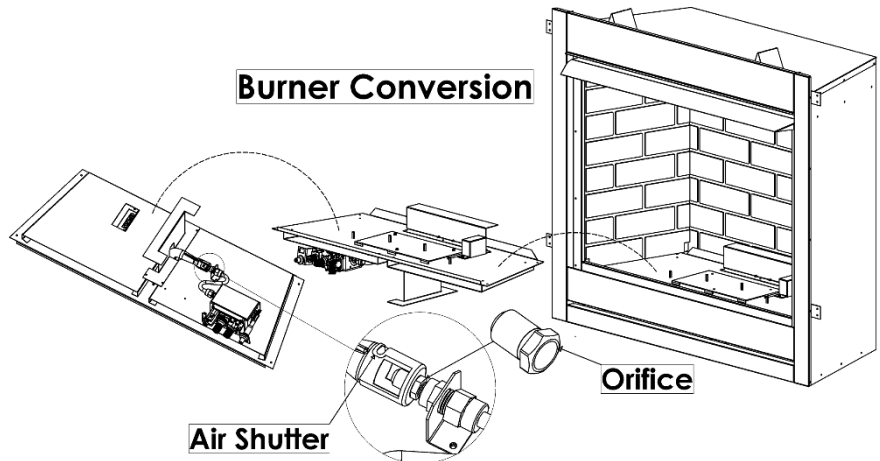

OFP42 Gas Conversion – Pilot – Part B

1. Shut off the gas supply to the appliance.
 2. Allow the pilot burner to cool to room temperature.
- ⚠ Warning:** Touching a hot pilot burner can result in injury.
3. Using a 10mm wrench, remove the pilot tube from the pilot burner assembly. The olive and injector can now be removed from the bottom of the pilot hood.

4. Verify that the new injector is proper for the application. LPG injectors have a RED top surface, while NG injectors do not. Refer to the Parts List in this manual for the proper injector.

5. Insert new injector into bottom of pilot hood. Replace olive and reconnect pilot tube.

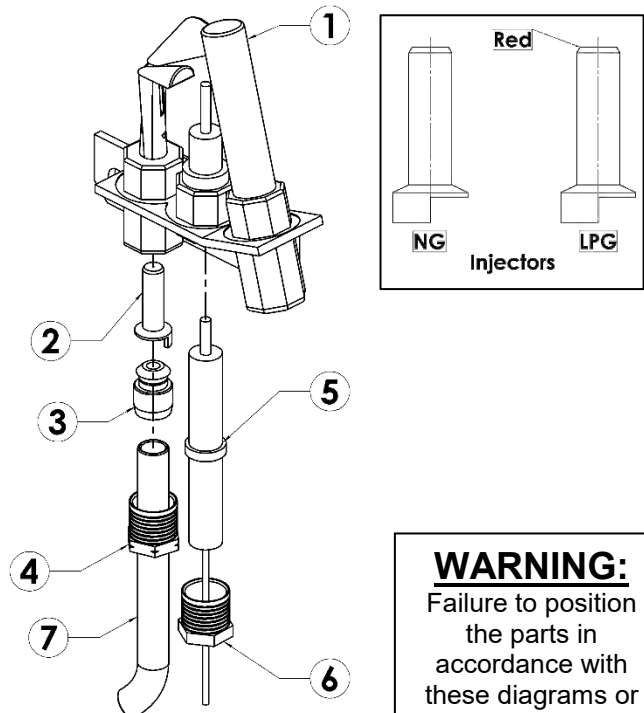

ITEM NO.	PART NUMBER
1	Thermopile
2	Injector
3	Olive
4	Pilot Tube Nut
5	Spark Electrode
6	Electrode Nut
7	1/4" Pilot Tube

WARNING:

Failure to position the parts in accordance with these diagrams or failure to use only parts specifically approved with this appliance may result in property damage or personal injury.

⚠ - Warning -

This conversion kit must only be applied as part of a conversion kit supplied by the appliance Manufacturer for the specific appliance, and type of gas being converted.

Installer Notice: These instructions must be left with appliance.



Instructions for converting SIT 190 series pilot burner injector from NG to PROPANE and from PROPANE to NG only. This information should be considered as supplemental to the Appliance Manufacturer's Instructions.

WARNING! The installation of this conversion kit must only be undertaken by a qualified and certified gas appliance installer.

1. Shut-off the gas supply to the appliance.
2. Allow the pilot burner to cool to room temperature.

WARNING: Touching a hot pilot burner can result in injury.

3. The pilot hood is held in place by spring. First remove the spring, then remove the hood by pulling it up from the pilot bracket (fig. 1).
4. Insert a 5/32" or 4 mm Allen wrench into the hexagonal key-way of the injector (fig. 2), and rotate it counter-clockwise until it is free of the injector journal.
5. Verify that the new injector is proper for the application. The injector size is stamped on the side of the injector near the top. Propane injectors have a groove machined around their circumference near the top, while NG injectors do not have a groove (fig. 4). Refer to the Appliance Manufacturer's instruction sheet for the proper injector size.
6. Insert the Allen wrench into the end of the injector. Then, insert the injector into injector journal, and rotate the injector clockwise until a torque of 9 lbf in (1.0 Nm) is achieved.
7. First replace the pilot hood by aligning the tab on the base of the hood with the slot in the side of the pilot journal, and push the hood down, onto the pilot bracket (fig. 3). The hood must sit squarely on the bracket for proper operation. Then replace the spring by pushing it on his seat (fig.3). Check to insure that the hood is properly seated onto the pilot bracket and that the spring is properly inserted onto his seat.
8. Restore the gas supply to the appliance, and ignite the pilot burner. Verify proper ignition and operation.

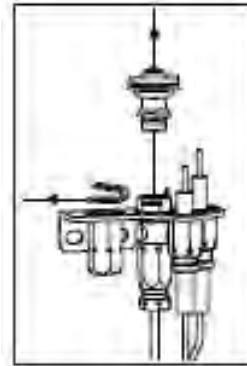

fig. 1

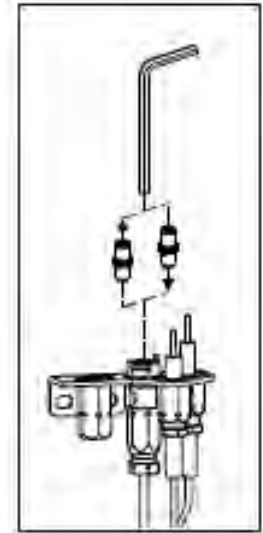

fig. 2



fig. 3

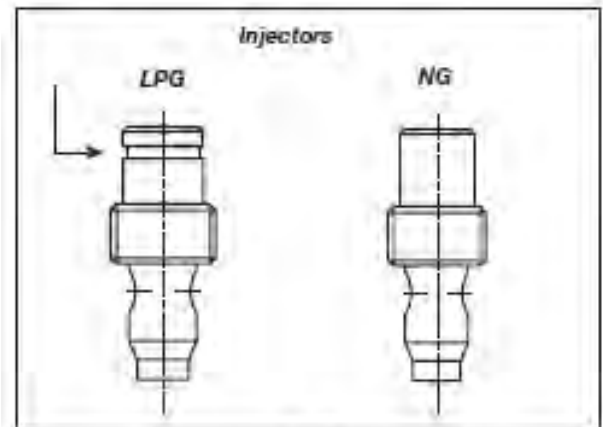

fig. 4

WARNING!

This conversion kit must **ONLY** be applied as part of a conversion kit supplied by the **APPLIANCE MANUFACTURER** for the specific appliance, and type of gas, being converted.



SIT GROUP

www.sitgroup.it

installation instructions

7.252.136

820 NOVA mV

Modulating Conversion Kit



WARNING!

The installation of this conversion kit must only be undertaken by a qualified and certified gas appliance installer.

MODULATING PRESSURE REGULATOR CONVERSION KIT INSTALLATION OR REPLACEMENT INSTRUCTIONS.

- 1 Turn control knob to the OFF position, and shut off the gas supply to the valve.
- 2 Using a Torx T20, or slotted screwdriver, remove and discard the three pressure regulator mounting screws (A), pressure regulator tower (B), and the spring and diaphragm assembly (C).
(If applicable)
- 3 Insure that the rubber gasket (D) is properly positioned and install the new modulating pressure regulator assembly to the valve using the new screws (E) supplied with the kit. Tighten screws securely.
(Reference torque = 25 In.Lb.)
- 4 Install the enclosed identification label (F) to the valve body where it can be easily seen.
- 5 Apply gas to system and re-light appliance according to manufacturers instructions.
- 6 With the main burner "ON", test the new pressure regulator assembly for leaks using a soap solution.
- 7 Relight the main burner in both the HI and LO positions, and verify proper burner ignition and operation.

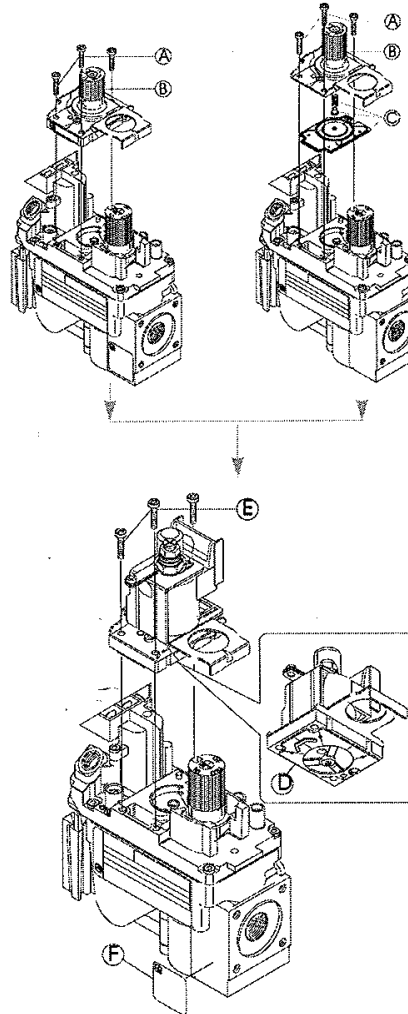

WARNING!

This modulating conversion kit must ONLY be applied as part of a conversion kit supplied by the APPLIANCE MANUFACTURER for the specific appliance, and type of gas, being converted.

INSTALLER NOTICE. These instructions must be left with appliance.



SIT Group

- Lighting Instructions - Intermittent Pilot Ignition System (IPI)

FOR YOUR SAFETY READ BEFORE LIGHTING

WARNING: If you do not follow these instructions exactly, a fire or explosion may result causing property damage, personal injury or loss of life.

Always light the pilot whether for the first time or if the gas supply has run out with the glass door opened or removed.

BEFORE LIGHTING:

- A. This appliance is equipped with an ignition device which automatically lights the pilot. Do not try to light the pilot by hand.
 - B. **BEFORE OPERATING** smell around the appliance area for gas. Be sure to smell next to the floor because some gas is heavier than air and will settle on the floor.
- WHAT TO DO IF YOU SMELL GAS
- Do not try to light any appliance.
 - Do not touch any electric switch; do not use any phone in your building.
 - Immediately call your gas supplier from a neighbor's phone. Follow the gas supplier's instructions.
- C. If you cannot reach your gas supplier, call the fire department.
 - D. Do not use this appliance if any part has been under water. Immediately call a qualified service technician to inspect the appliance and replace any part of the control system and any gas control which has been under water.
 - D. If the gas valve requires repair, call a qualified service technician. Force or attempted repair may result in a fire or explosion.

OPERATING INSTRUCTIONS

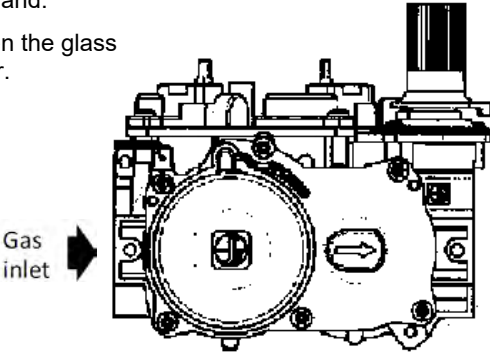
1. Stop! Read the safety information above on this label.
 2. Remove batteries from receiver, and/or Battery Backup Pack.
 3. Turn off all electric power to the appliance.
 4. This appliance is equipped with an ignition device which automatically lights the pilot. Do not try to light the pilot by hand.
 5. Open the glass door.
- 
6. Turn manual shutoff valve clockwise ↻ to off (Located behind the access panel).
 7. Wait five (5) minutes to clear out any gas. Then smell for gas, including near the floor. If you smell gas, STOP! Follow "B" in the safety information above this label. If you do not smell gas, go to next step.
 8. Turn manual shutoff valve counter-clockwise ↻ to on.
 9. Close the glass door.
 10. Turn on all electric power to the fireplace and re-install batteries into the Transmitter/Receiver, and/or Battery Backup Pack.
 11. Turn "On" Switch that operates the Main Burner. If using a Remote Control refer to Remote Control Operation Manual for activation.
 12. If the appliance will not operate, follow the instructions "To Turn Off Gas To Appliance" and call your service technician or gas supplier.

TO TURN OFF GAS TO APPLIANCE

1. Turn off all electric power to the fireplace if service is to be performed, including removing batteries from Remote Transmitter/Receiver and/or Battery Backup Pack.
2. Remove control access panel.
3. Turn manual shutoff valve clockwise ↻ to off (Located behind the access panel).
If alternate shut-off valve was installed it can be shut off instead of going through the fireplace to access the fireplace shutoff valve.
4. Replace control access panel.

Overview

The IPI system is an advanced burner controller that provides you with the option of having either a Standing-Pilot, or an intermittent igniting system. This alternating mode is controlled by the CPI/IPI Switch (Continuous Pilot Ignition/Intermittent Pilot Ignition) located on the IPI System Box. The difference between a Standing-Pilot and an Intermittent-Pilot is in whether the pilot stays lit or shuts off:

In Standing-Pilot, the pilot assembly is lit by the IPI Main Module and continues to stay lit until 1) the CPI/IPI Switch is switched to the IPI position; 2) a loss of electrical power (battery and AC source), 3) the flame sensor loses its signal, 4) the fuel supply discontinues, or 5) the IPI Main Module malfunctions.

In the Intermittent-Pilot mode, the pilot shuts off when the appliance is not in use. The advantage of this mode is that fuel is not consumed when the fireplace is not operating.

NOTE: In some jurisdictions Intermittent-Pilot is required. That means the pilot cannot remain lit when the appliance is not operating.

Components

The core of the IPI system is the Main Module and the IPI Valve. With these two components the system is able to operate a gas fireplace. There are also other components available to complement the IPI system.

IPI System Cover: Is essential in keeping the components at their proper operating temperatures. **DO NOT OPERATE THE APPLIANCE WITHOUT THIS COVER.**

Modulating Servo Motor: Is an add-on valve component that permits HI/LO functionality to be controlled by the remote. Contrary to this feature is a Manual HI/LO Control Knob. The Modulating Servo Motor requires the Remote system to be present.

Backup Battery Pack: This component permits the IPI system to operate without the need for an external AC Adapter power source. The advantage to using the battery backup is that in the case of a power failure, the appliance is still operable.

NOTE: In certain instances the IPI Main Module requires resetting. This can occur if the system is unable to ignite the pilot or the main burner in the allotted time period. The IPI is programmed to lockout all commands. To reset this lockout you must deplete the system of all electrical power. This means to remove the batteries from the Battery Pack, remove the batteries from the Remote Receiver (if applicable), and disconnect the AC Adapter from the system. Leave the power off for approximately 25 seconds to clear its lockout.

Remote Receiver: This component provides the capability of controlling the appliance with a wireless remote transmitter.

Standing Pilot Mode for Colder Climates (Below Freezing)
 For IPI models it may be necessary to set the appliance to Standing Pilot mode to maintain heat in the cavity. The purpose of this procedure is to prevent cold air from penetrating the chimney and then onto the living space. Therefore, when the internal temperature is slightly elevated the fireplace is able to freely exhaust its combustion and hence making it easier to startup.
NOTE: The pilot system for this appliance may be equipped with a Seven Day Timer, in which case the pilot flame will be extinguished if the main burner has not been turned ON for seven days. This Seven Day Cycle is reset every time the main burner is cycled ON / OFF and the pilot remains lit. If more than seven days has passed since the main burner has been cycled ON / OFF and the pilot is also out, follow the procedures described in this manual to light the pilot.

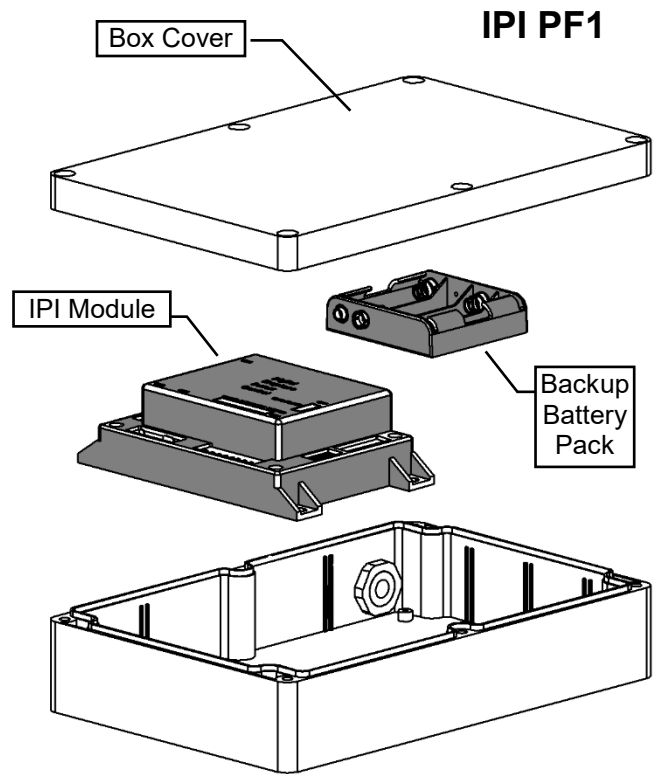

Proflame 1

-IPI System Parts List-

OFF42NE, OFF42NSE, OFF42LPE, OFF42LPSE

PART NO.	DESCRIPTION
1. 1006-P002SI	Valve IPI Hi/Lo NG
2. 1006-P003SI	Valve IPI Hi/Lo LP
3. 1002-P302SI	IPI Ignition Board
4. 1002-P047SI	Pilot Assembly-LP -24" Wire
5. 1002-P033SI	Pilot Assembly-NG -24" Wire
5-b. 1002-PSEC7524	Pilot Burner Convertible NG – 24" (Assembled)
6. 1002-P850SI	AC Wall Adapter
7. 1002-P12BH	Battery Pack
8. 1001-P280SI	TC - Tubing W/Fittings 1/8 2.182.280
9. 1001-P166SI	TC - Orifice Pilot NG 977.166 #62 (IPI)

10. 1001-P168SI	TC - Orifice Pilot LP 977.168 #35 (IPI)
11. 1002-P012SI	IPI Stepper Kit - LP 907.012
12. 1002-P013SI	IPI Stepper Kit - NG 907.013
13. 1002-P014SI	IPI Reg Kit - LP Hi-Lo 907.014
14. 1002-P016SI	IPI Reg Kit - NG Hi-Lo 907.016
15. 1002-P017SI	TC - Electrode Cable & Sparker IPI 915.017 24"
16. 1002-P119SI	TC - Electrode Cable & Sparker IPI 35" (Infinite, ZCVRB47, VRB46)
17. 1002-P903SI	TC - Electrode Flame Sense IPI 007.253/915.903 24"
18. 1002-P910SI	TC - Electrode Flame Sense 35" (Infinite, ZCVRB47, VRB46)

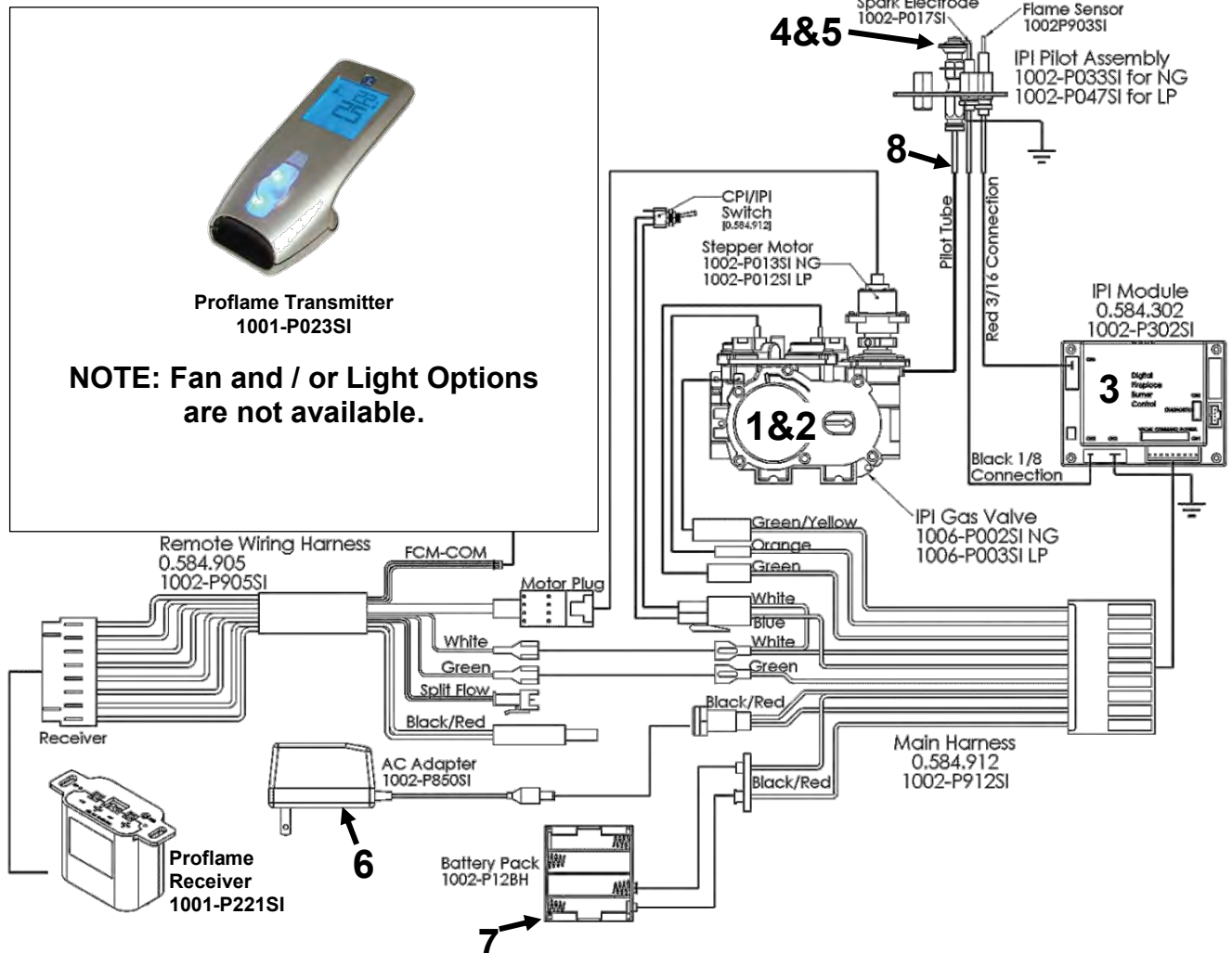

Operating the Receiver Without Batteries For GT / EGT / GTM / EGTM Remote Controls

- Wiring Harness P/N 1002-P906si required for both IPI & Millivolt systems.
- Millivolt Systems will also require Power Adapter P/N 1002-P850si.

The Remote Receiver & IPI or Millivolt system can be powered by the AC Adapter. This is advantageous if you do not want to use batteries. Simply connect the AC Adapter into the Remote Control Wiring Harness as per the diagrams below.

IPI System EGTM

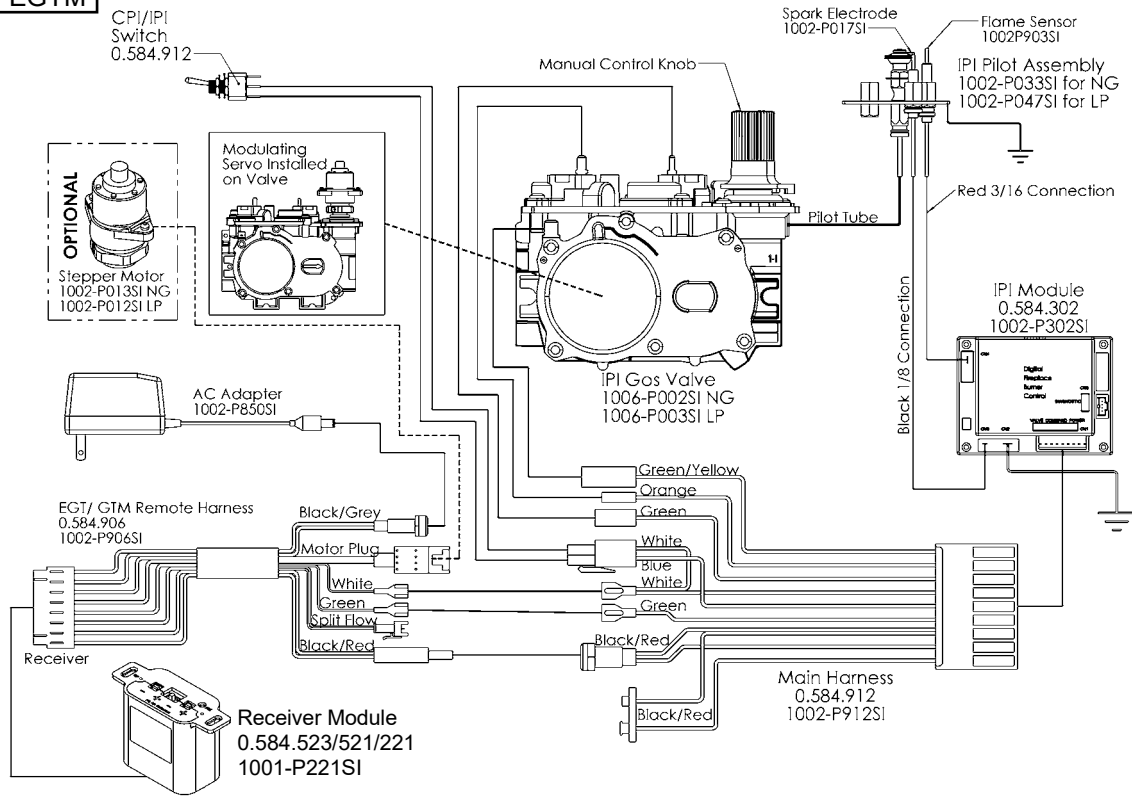

Millivolt System GTM

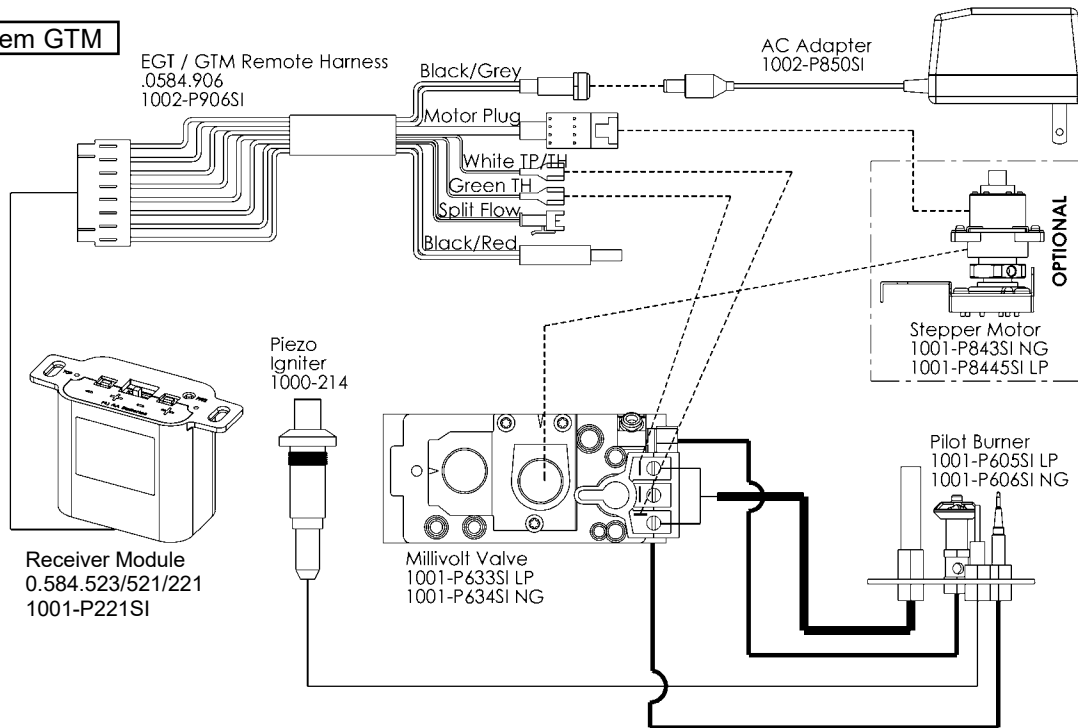

IPI Proflame 1 -Remote Control Operation-

The Proflame GTM is configured to control the on/off main burner operation, its flame levels, and provides on/off and Smart *thermostatic control of the appliance.

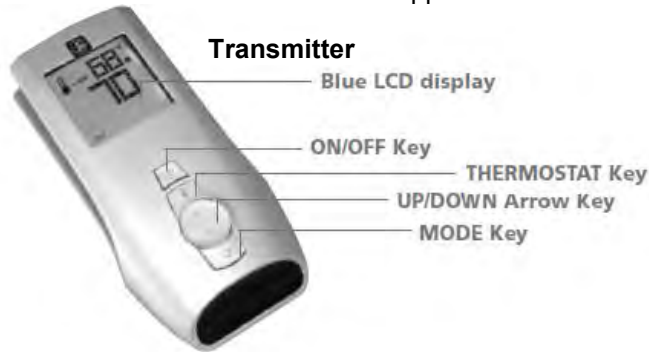

Remote Receiver



Transmitter

The Transmitter is powered by 3 AAA type batteries. A Mode Key is provided to Index between the features and a *thermostat Key is used to turn on/off or index through *thermostat functions

Remote Receiver

The Receiver connects directly to the gas valve and stepper motor with a wiring harness. The Receiver is powered by 4 AA type batteries. The Receiver three position slider switch can be set to one of three positions: ON (Manual Override), Remote (Remote control) or Off.

Initializing the System for the first time

Install 4 AA batteries into the receiver battery bay. Install 3 AAA type batteries in the Transmitter battery bay. Place the 3 position slider switch in the "Remote" position. Insert the end of a paper clip into the hole marked "PRG" on the Receiver front cover. The Receiver will "beep" three (3) times to indicate that it is ready to synchronize with a Transmitter. Push the On button. The Receiver will "beep" four times to indicate the Transmitter's command is accepted. The system is now initialized.

Temperature indication Display

With the system in the "OFF" position, press the *thermostat Key and the Mode Key at the same time. Look at the LCD screen on the Transmitter to verify that a C or F is visible to the right of the Room Temperature display.

Turn the Appliance On or Off

Press the ON/OFF Key on the Transmitter

Remote Flame Control

The Proflame GTM has six (6) flame levels. Pressing the Down Arrow Key once will reduce the flame height by one step until the flame is turned off. The Up Arrow Key will increase the flame height each time it is pressed. If the Up Arrow Key is pressed while the system is on but the flame is off, the flame will come on in the high position.

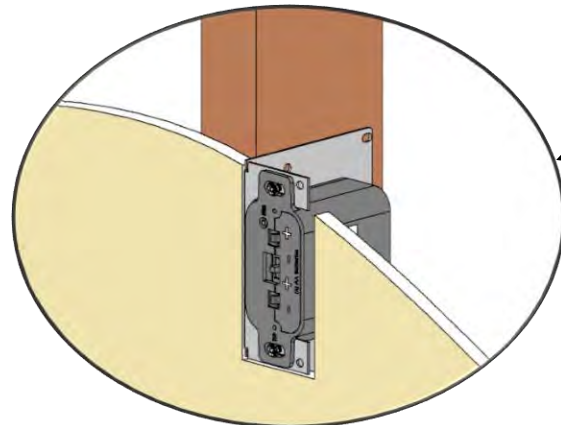

Wall Mount Option

10ft. Extension Harness (Part No. 1001-P904SI) required.

- The Remote Receiver can be mounted on a vertical wall stud using the DCHS as a mounting bracket.
- Ensure that the face is protruding 1/2" so that the face plate will be flush on the face of the wall.
- Drywall cutout size is 2" wide by 4-1/8" tall.
- Must be installed within 10ft of valve assembly (6ft recommended).

Room *thermostat (Transmitter Operation)

The Remote Control can operate as a room *thermostat. To activate this function, press the *thermostat Key. The LCD display on the Transmitter will change to show that the room *thermostat is "ON" and the set temperature is now displayed. To adjust the set temperature, press the Up or Down Arrow Keys until the desired set temperature is displayed on the LCD screen of the Transmitter.

Smart *thermostat (Transmitter Operation)

The Smart *thermostat function adjusts the flame height in accordance to the difference between the set point temperature and the actual room temperatures. As the room temperature gets closer to the set point the Smart Function will modulate the flame down. To activate this function, press the *thermostat Key until the word "SMART" appears to the right of the temperature bulb graphic. To adjust the set temperature, press the Up or Down arrow Keys until the desired set point temperature is displayed.

Key Lock Function

This function will lock the keys to avoid unsupervised operation. To activate this function, press the MODE and the UP Arrow Key at the same time. To de-activate this function, press the MODE and the UP Arrow Key at the same time.

Low Battery Detection

Transmitter - When the Transmitter batteries are low, a Battery Icon will appear on the LCD display of the Transmitter.
Receiver - When the Receiver batteries are low, No "beep" will be emitted from the Receiver when it receives an On/Off command from the Transmitter. When the batteries are replaced the "beep" will be emitted from the Receiver when the ON/OFF Key is pressed (See Initializing the System for the first time).

Manual Bypass Of The Remote System

If the batteries of the Receiver or Transmitter are low or depleted, the appliance can be turned on manually by sliding the three position slider switch on the Receiver to the ON position. This will bypass the remote control feature and the appliance main burner will come on if the gas valve is in the "On" position.

IPI Proflame 2 IFC Module and Remote Control

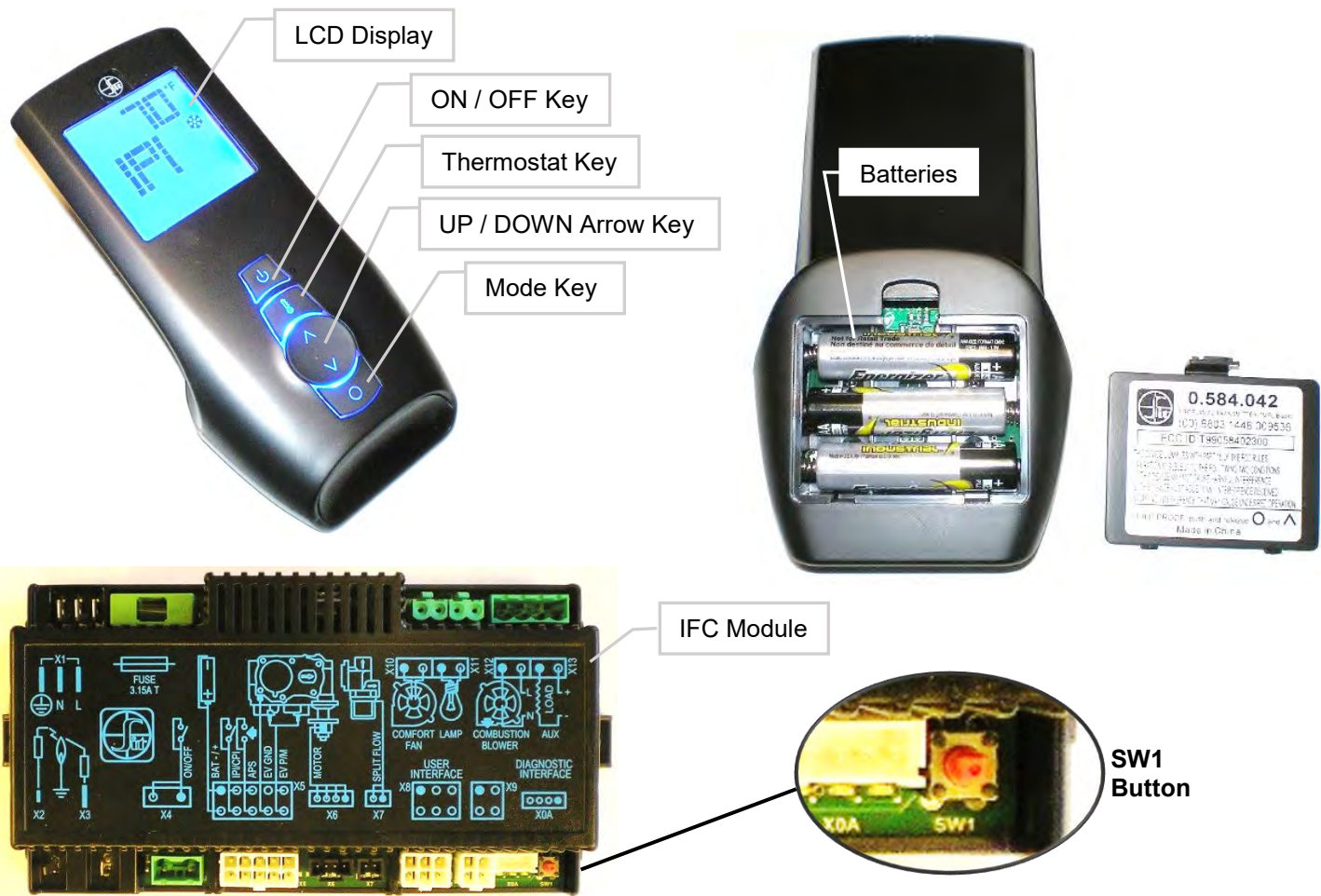

Pairing Remote Control:

- Install the 3 AAA type batteries in the battery bay, located on the base of the Remote Control. Note polarity of the batteries and insert them as indicated.
- Connect the AC power supply to the IFC Module.
- Press the SW1 button on the IFC Module so the IFC will “beep” and a red LED is illuminated to indicate that the IFC Module is ready to synchronize with a Remote Control within 10 seconds. With the batteries already installed in the Remote Control, push the ON button. The receiver will “beep” four times to indicate the Remote Control’s command is accepted.

The system is now initialized.

Resetting Proflame 2 IFC Module for Manual Use

If the transmitter gets misplaced, is broken, or is no longer wanted the PF2 Module can be reset to a manual system. A manual on/off switch or thermostat may be installed at the X4 connector (this connection is Jumped at the factory) no power is required.

The following sequence must be followed to reset the PF2 Module:

- Press the Red **SW1** button until you hear three beeps.

- Within 10 seconds press the **SW1** button again until you hear it beep.
- The PF2 Module may now be turned on/off manually (x4 connector) by a switch (not supplied), the pilot will remain on CPI (continuous pilot ignition) mode, all other functions of main burner, fan and lights will be on the high setting.

Fan Startup and Shutdown Timings:

Fan setting is started with a delay of 5 minutes from the fireplace ignition and stopped with a delay of 12 minutes from the fireplace switching off.

Low Battery Power Detection

When the Remote Control’s batteries are low, a Battery Icon will appear on the LCD display before all power is lost. When the batteries are replaced this icon will disappear.

Battery Backup

The PF2 module is powered by line voltage (AC) with provision of battery backup in case of main power loss. Fans and lighting features will not function with the PF2 Module is powered by battery backup. It is recommended that the 4 x AA batteries are changed before each heating season.

Proflame 2 –NE2 / LPE2

-IPI System Parts List-

OFP42NE2, OFP42NSE2, OFP42LPE2, OFP42LPSE2

IPI PROFLAME 2 - COMPONENT PARTS

PART NO.	DESCRIPTION
1. 1005-P001SI	Valve IPI Proflame PF2 885.001 NG - Stepper
2. 1005-P002SI	Valve IPI Proflame PF2 885.002 LP - Stepper
3. 1005-P325SI	Module IPI - Proflame 2 - 584.665
4. 1005-P627SI	Module IPI – Proflame 2 - Basic - 584.627
5. 1005-P924SI	Harness PF2 - 584.924
6. 1005-P042SI	Transmitter - PF2 - Black 584.042
7. 584-PWR-C	Wire Harness PF2 – Power Cord
8. 584-X4P	Terminal Block
9. 584-X10	Wire Harness PF2
10. 584-ACC01-C	Wire Harness PF2 - Fan/Light
11. 584-X8-B	Wire Harness PF2 - Optional Reset Harness
12. 584-X12	Optional Power Vent Harness

NOTE: Fan and / or Light Options are not available.



6 Proflame Transmitter
0.584.042

IPI - PF1 and PF2 Common Components

PART NO.	DESCRIPTION	
13. 1002-P033SI	TC - Pilot Burner IPI (Assembled) NG 199.033	
13b. 1002-PSEC7524	Pilot Burner Convertible NG – 24" (Assembled)	
14. 1002-P047SI	TC - Pilot Burner IPI (Assembled) LP 199.047	
15. 1001-P166SI	TC - Orifice Pilot NG 977.166 #62 (IPI)	
16. 1001-P168SI	TC - Orifice Pilot LP 977.168 #35 (IPI)	
17. 1001-P280SI	TC - Tubing W/Fittings 1/8 2.182.280	
18. 1002-P012SI	IPI Stepper Kit - LP 907.012	P2 CONVERSION
19. 1002-P013SI	IPI Stepper Kit - NG 907.013	
20. 1002-P014SI	IPI Reg Kit - LP Hi-Lo 907.014	P1 CONVERSION
21. 1002-P016SI	IPI Reg Kit - NG Hi-Lo 907.016	
22. 1002-P017SI	TC - Electrode Cable & Sparker IPI 915.017 24"	
23. 1002-P119SI	TC - Electrode Cable & Sparker IPI 35" (Infinite, ZCVRB47, VRB46)	
24. 1002-P12BH	IPI Battery Housing 12bh347-Gr	
25. 1002-P903SI	TC - Electrode Flame Sense IPI 007.253/915.903 24"	
26. 1002-P910SI	TC - Electrode Flame Sense 35" (Infinite, ZCVRB47, VRB46)	

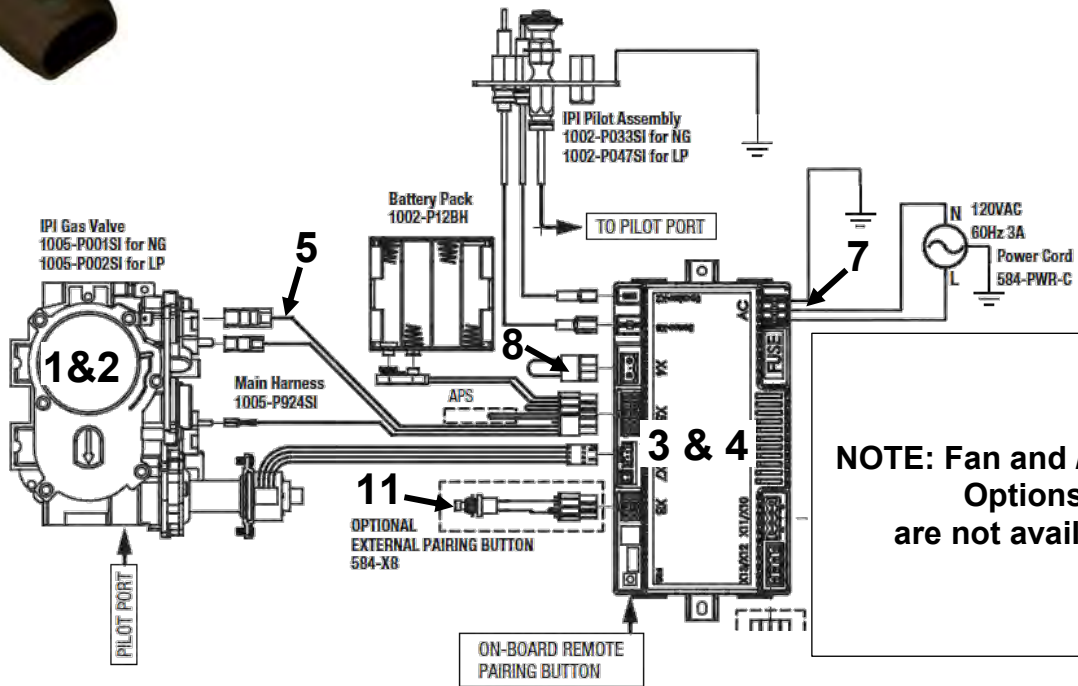

NOTE: Fan and / or Light Options are not available.



IPI Proflame 2 System Configuration: Modulating Controls Simplified Wiring Diagram

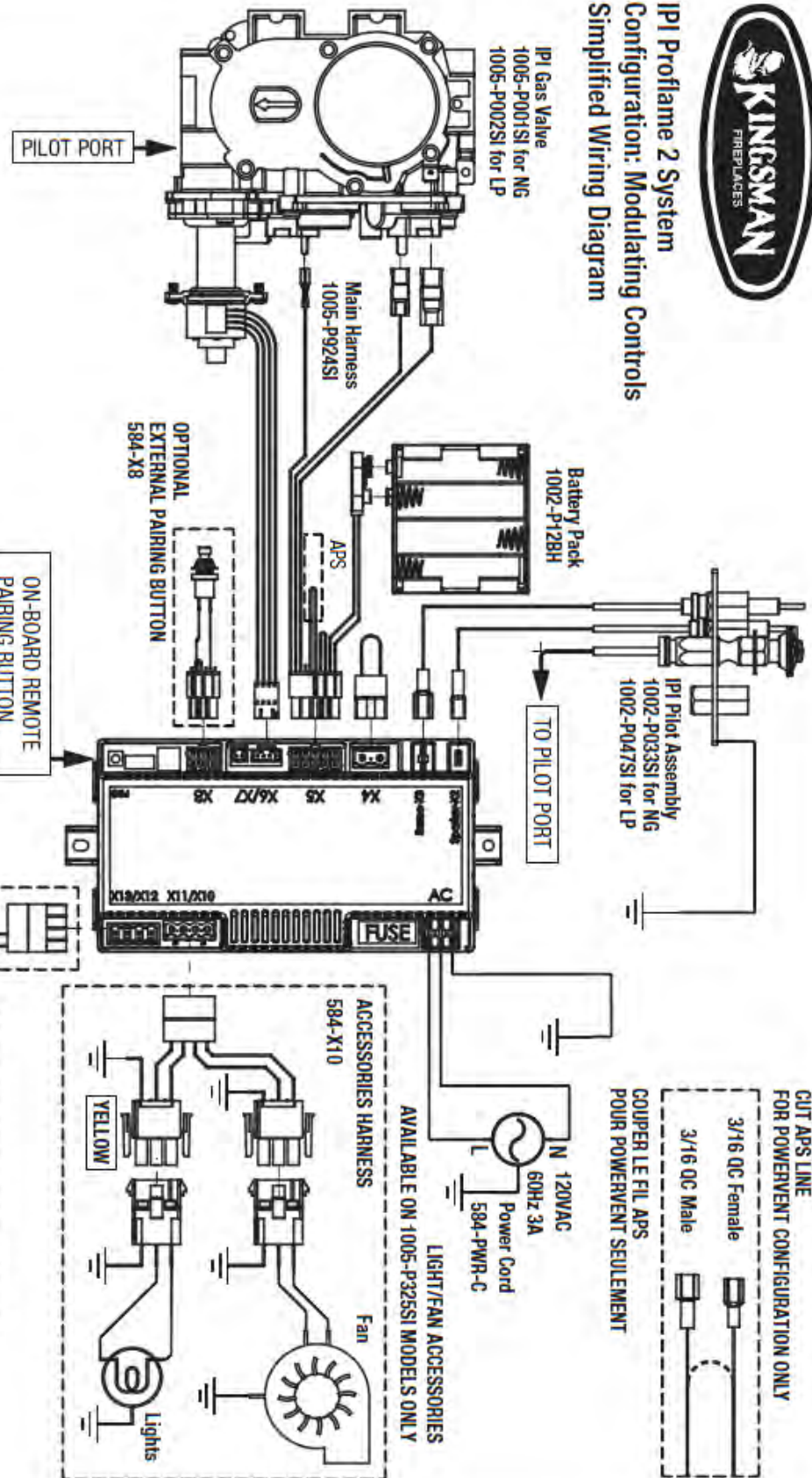

Manufactured by: Kingsman Fireplaces
2340 Logan Avenue
Winnipeg, MB R2R 2V3

For use with all Kingsman manufactured IPI Proflame 2 models, for all types of gas noted on rating plate. Supply 120VAC 60Hz 3A, 6 volts battery backup.

Pour utilisation avec tous les modèles IPI Proflame 2 fabriqués par Kingsman, pour tous les types de gaz noté sur la plaque signalétique. Voltage d'alimentation: 120VAC 60Hz 3A et 6 volts pour le bloc-piles de secours.

This component should be installed by a qualified service agency.
Cette composante doit être installée par une entreprise de service qualifiée.

Part #1005-P2SC4

OFP42 Troubleshooting the Gas Control System

NOTE: Before troubleshooting the gas control system, be sure external gas shut off is in the "ON" position.

Problem	Possible Causes	Corrective Action
Spark igniter will not light	Defective or misaligned electrode at pilot.	Check for spark at electrode and pilot: if no spark and electrode wire is properly connected, replace igniter.
	Defective igniter (push-button)	Using a match, light pilot. If pilot lights, turn off pilot and push the red button again. If pilot will not light, check gap at electrode and pilot- gap should be 1/8" to 1/4" to have a strong spark.
Pilot will not light	Safety Switch is Depressed.	Clear any obstructions and make sure Lever Arm is not bent or damaged (See Panel 2 page 10 for Safety Switch Location).
Pilot will not stay lit after carefully following lighting instructions.	Defective Valve Magnet	Turn valve knob "ON", place wall switch "ON". Millivolt meter should read greater than 100mv. If the reading is okay and the burner does not come on, replace the gas valve.
Pilot burning, no gas to burner, Valve knob "ON", Wall Switch "ON"	Wall Switch or wires defective	Check wall switch and wires for proper connections. Jumper wire across terminals at wall switch. If burner comes on, replace defective wall switch. If okay, jumper wire across wall switch wires at valve. If burner comes on, wires are faulty or connections are bad.
	Generator may not be generating sufficient voltage	Check generator with millivolt meter. Take reading at generator terminals of gas valve. Should read 325 millivolts minimum while holding valve knob depressed in pilot position and wall switch "OFF". Replace faulty generator if reading is below specified minimum.
	Plugged burner orifice	Check burner orifice for stoppage and remove.
	Defective automatic valve operator	Remove all switch wires from gas valve. Install jumper wires from TPTH and TH terminals of gas valve. Turn valve "ON". If main burner does not light, replace valve.
Frequent Pilot outage problem	Pilot flame may be too low or blowing (high) causing the pilot safety to drop out.	Clean and/or adjust pilot flame for maximum flame impingement on generator.
	Windy Conditions.	Close Pullscreens

*NOTE: The pilot system for this appliance may be equipped with a **Seven Day Timer**, in which case the pilot flame will be extinguished if the main burner has not been turned ON for seven days. This Seven Day Cycle is reset every time the main burner is cycled ON / OFF and the pilot remains lit. If more than seven days has passed since the main burner has been cycled ON / OFF and the pilot is also out, follow the procedures described in this manual to light the pilot.

OFP42 -Cleaning -

It is recommended to annually inspect and clean the unit to prevent malfunction and / or sooting. This operation should be performed by your dealer or a qualified technician. Carefully remove contents of firebox (log set, Rocks, Glass, etc.). Gloves are recommended.

- WARNING -

Turn off Unit and allow to cool before cleaning. Only a qualified service technician should service and repair appliance.

(Burner Assembly shown removed for clarity.)

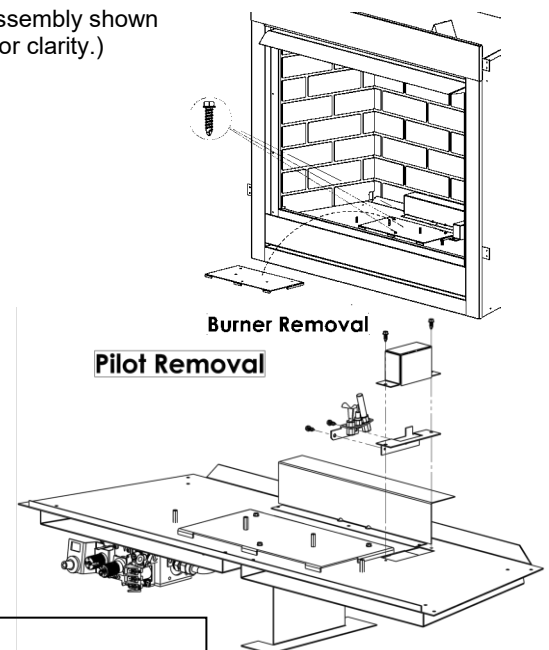

Annual Cleaning / Inspection

- Do not use cleaning fluids to clean logs.
- Use a soft bristle brush or a vacuum with brush attachment.
- Vacuum loose particles and dust from burner and valve
- Inspect Burner Plate, Pilot, Valve, and Mixing Sleeve for spider webs or other blockages.
- If the burner or any other component is found to be faulty, it must be replaced prior to operation of the appliance with an approved component. **Replacement burner must be as specified in the manual.**
- Replace contents of firebox. **Refer to the appropriate page in this manual for proper placement of contents, such as logs.**

WARNING:

Failure to position the parts in accordance with these diagrams or failure to use only parts specifically approved with this appliance may result in property damage or personal injury.

Part Number Description

Listed for USA/Canada For Outdoor Use Only

OFP42N	Outdoor Fireplace, Satin Coat Black, SIT Nova TMV Valve with Hi/Lo Adjustment Wall Switch, Stainless Steel Screens, Millivolt Natural Gas, 55,000 BTU
OFP42NE	Outdoor Fireplace, Satin Coat Black, SIT Proflame IPI Valve, Wall Switch, Stainless Steel Screens, Natural Gas, 55,000 BTU
OFP42NE2	Outdoor Fireplace, Satin Coat Black, SIT Proflame 2 IPI Valve, Remote Control, Stainless Steel Screens, Natural Gas, 55,000 BTU
OFP42NS	Outdoor Fireplace, Stainless Steel, SIT Nova TMV Valve with Hi/Lo Adjustment Wall Switch, Stainless Steel Screens, Millivolt Natural Gas, 55,000 BTU
OFP42NSE	Outdoor Fireplace, Stainless Steel, SIT Proflame IPI Valve, Wall Switch, Stainless Steel Screens, Natural Gas, 55,000 BTU
OFP42NSE2	Outdoor Fireplace, Stainless Steel, SIT Proflame 2 IPI Valve, Remote Control, Stainless Steel Screens, Natural Gas, 55,000 BTU
OFP42LP	Outdoor Fireplace, Satin Coat Black, SIT Nova TMV Valve with Hi/Lo Adjustment Wall Switch, Stainless Steel Screens, Millivolt, Propane, 55,000 BTU
OFP42LPE	Outdoor Fireplace, Satin Coat Black, SIT Proflame IPI Valve, Wall Switch, Stainless Steel Screens, Propane, 55,000 BTU
OFP42LPE2	Outdoor Fireplace, Satin Coat Black, SIT Proflame 2 IPI Valve, Remote Control, Stainless Steel Screens, Propane, 55,000 BTU
OFP42LPS	Outdoor Fireplace, Stainless Steel, SIT Nova TMV Valve with Hi/Lo Adjustment Wall Switch, Stainless Steel Screens, Millivolt, Propane, 55,000 BTU
OFP42LPSE	Outdoor Fireplace, Stainless Steel, SIT Proflame IPI Valve, Wall Switch, Stainless Steel Screens, Propane, 55,000 BTU
OFP42LPSE2	Outdoor Fireplace, Stainless Steel, SIT Proflame 2 IPI Valve, Remote Control, Stainless Steel Screens, Propane, 55,000 BTU

Conversion Kits

42OFP-CKLP	Conversion Kit – Propane – Millivolt 55,000 BTU
42OFP-CKLPI	Conversion Kit – Propane – Proflame 1 IPI 55,000 BTU
42OFP-CKLP2	Conversion Kit – Propane – Proflame 2 IPI 55,000 BTU
42OFP-CKNG	Conversion Kit – Natural Gas - Millivolt 55,000 BTU
42OFP-CKNGI	Conversion Kit – Natural Gas – Proflame 1 IPI 55,000 BTU
42OFP-CKNG2	Conversion Kit – Natural Gas – Proflame 2 IPI 55,000 BTU

Fireplace Requirements

Log Sets or Rock Kits required for Fireplace

LOGF37	Log Set -7pce. Burnt Oak
MQROCK1	Rock Set Tan
MQROCK2	Rock Set Natural
MQROCK3	Rock Set Multi-Color
MQG10W	Decorative Glass 1/2" White 10lbs
MQG10B	Decorative Glass 1/4" Black 10lbs

Fireplace Accessories

OFP42SS	Surround Stainless Steel Coverage (37"H x 42-3/16" W)
OFP42WCSS	Weather Cover (Stainless Steel)

Liners

OFP42RLT	Refractory Liner Traditional /Reversible
OFP42RLH	Refractory Liner Herringbone /Reversible

Replacement Burner Assembly

42OFP-BLPSI	Burner Assembly- Propane c/w Valve System (OFP42LP, OFP42LPS)
42OFP -BNGSI	Burner Assembly- Natural Gas c/w Valve System (OFP42N, OFP42NS)
42OFP -BLPSIE	Burner Assembly- Propane c/w Valve System (OFP42LPE, OFP42LPSE)
42OFP -BNGSIE	Burner Assembly- Natural Gas c/w Valve System (OFP42NE, OFP42NSE)
42OFP -BLPE2	Burner Assembly- Propane c/w Valve System (OFP42LPE2, OFP42LPSE2)
42OFP -BNE2	Burner Assembly- Natural Gas c/w Valve System (OFP42LPE2, OFP42NSE2)

Miscellaneous and Replacement Parts

42OFP-126	Stainless Steel Pullscreens – 2 Each
42OFP-131	Pullscreen Rods – 2 Each
42OFP-108	Deflector Hood
42OFP-108SS	Deflector Hood – Stainless Steel
1000-214	#Piezo Igniter 1244-17 MARK 21
1000-215	#Pal Nut (18MMXI.5MM)BLK(1364.03)
1000-218	#Switch Ivory (1451/001)
1000-255	#Orifice Brass – (State Size)

Valve System Parts / Millivolt

1001-P069SI	Electrode Sparker 915.069 TC SIT
1000-P136WR	Generator / Thermopile
1001-P165SI	Orifice Pilot NG 977.165 TC SIT
1001-P167SI	Orifice Pilot LP 977.167 TC SIT
1001-P216SI	Thermocouple 290.216 TC SIT
1001-P280SI	Pilot Tube c/w Fittings 24"
1001-P633SI	Valve Nova LP Hi/Lo 0820651
1001-P634SI	Valve Nova NG Hi/Lo 0820652
1001-P713SI	Pilot Burner LP 199.713 TC SIT
1001-P714SI	Pilot Burner NG 199.714 TC SIT

Remote Control / Millivolt

GFRC	Remote Control Millivolt / IPI – On/Off
GTRC	Remote Control Millivolt - Thermostat
GTMRCN	Remote Control Millivolt – Thermostat/Modulating - NG
GTMRCP	Remote Control Millivolt – Thermostat/Modulating - LP
DCHS	Remote Control Heatshield

Electronic Ignition Replacement Parts IPI

1006-P002si	Valve IPI (NG; Hi/Lo)
1006-P003si	Valve IPI (LP; Hi/Lo)
1002-P047si	Pilot Assembly (LP)
1002-P033si	Pilot Assembly (NG)
1002-PSEC7524	Pilot Burner Convertible NG – 24” (Assembled)
1002-P089si	Spark Electrode (Long)
1002-P113si	Electrode Flame Sensor (Long)
1002-P302si	IPI Ignition Board
1002-P850si	AC Wall Adapter
1002-P12BH	Battery Pack
1002-P912si	Wiring Harness
1001-P166si	Orifice Pilot (NG)
1001-P168si	Orifice Pilot (LP)
1002-P013si	Stepper Motor (NG)
1002-P012si	Stepper Motor (LP)
1002-P016si	Hi/Lo Regulator (NG)
1002-P014si	Hi/Lo Regulator (LP)

Electronic Ignition/Remote Control IPI

EGTRC	Remote Control IPI (Thermostat)
EGTMRCN	Remote Control IPI (Thermostat/Modulating - NG)
EGTMRCP	Remote Control IPI (Thermostat/Modulating - LP)

LIMITED WARRANTY



Save this certificate. It gives you specific legal rights, and you may also have other rights which may vary from one province or state to another.

In the event your unit needs servicing contact your dealer or contractor who installed or services your unit. When requesting service, please have the model and serial number from each unit readily available. If your dealer needs assistance, the distributor is available for support and we, in turn support the distributor's efforts.

Fill in the installation date and model and serial numbers of the unit in the space provided below and retain this limited warranty for your files.

GENERAL TERMS

This limited warranty applies only while the unit remains at the site of the original installation and only if the unit is installed inside the continental United States, Alaska, Hawaii and Canada. The warranty applies only if the unit is installed and operated in accordance with the printed instructions and in compliance with applicable installation, building codes and good trade practices.

The burner is warranted against defects for five years. All other components such as gas valves, thermocouples, igniters, lights and media are warranted against defects for one year.

This limited warranty further does not cover any scratches, dents, painted finishes, corrosion or discoloring by heat, abrasive and chemical cleaners, nor chipping on powder coated parts.

During the first year after installation, we will provide a replacement for any component part of your unit found to be defective in materials or workmanship. The part to be replaced must be returned to our distributor in exchange for the replacement part.

In lieu of providing a replacement part, we may, at our option, provide the distributor's component purchase price from us or a credit equal to the distributor's component purchase price from us toward the purchase of any new unit which we distribute. If a credit is given in lieu of a replacement part, the rating plate from the unit being replaced must be submitted on a warranty claim and the unit being replaced must be made available to our distributor for disposition.

In establishing the date of installation for any purpose including determination of the starting date for the term of this limited warranty, reasonable proof of the original installation date must be presented*, otherwise the effective date will be based upon the date of manufacture plus thirty (30) days.

Any labor, material, freight and/or handling charges associated with any repair or replacement pursuant to this limited warranty will be your responsibility. In this warranty the word "installation" means original installation.

We will not be responsible for and you the user will pay for: (a) damages caused by accident, abuse, negligence, misuse, riot, fire, flood, or Acts of God (b) damages caused by operating the unit where there is a corrosive atmosphere containing chlorine, fluorine, or any other damaging chemicals (other than in a normal residential environment) (c) damages caused by any unauthorized alteration or repair of the unit affecting its stability or performance (d) damages caused by improper matching or application of the unit or the unit's components (e) damages caused by failing to provide proper maintenance and service to the unit (f) any expenses incurred for erecting disconnecting or dismantling the unit (g) parts or supplies used in connection with service or maintenance (h) damage repairs, inoperation or inefficiency resulting from faulty installation or application (i) electricity or fuel costs or any increase in electricity or fuel cost whatsoever including additional or unusual use of supplemental electric heat.

We shall not be liable for any incidental, consequential, or special damages or expenses in connection with any use or failure of this unit. We have not made and do not make any representation or warranty of fitness for a particular use or purpose and there is no implied condition of fitness for a particular use or purpose. We make no express warranties except as stated in this limited warranty. No one is authorized to change this limited warranty or to create for us any other obligation or liability in connections with this unit. Any implied warranties shall last for one year after the original installation. Some states and provinces do not allow the exclusion or limitation of incidental or consequential damages or do not allow limitations on how long an implied Warranty or condition lasts so the above limitations or exclusions may not apply to you. The provisions of this limited warranty are in additions to and not a modification of or subtraction from any statutory warranties and other rights and remedies provided by law.

Model No.: _____ Serial No.: _____

Date Installed: _____

*You must retain the original records that can establish the installation date of your unit.