

FIRE CHIEF FURNACE

**WOOD AND COAL BURNING
INDOOR FURNACE**

MODEL FC300F



Shown with optional filter box installed.

**Manufactured by:
Fire Chief Industries
10950 Linpage Place
Saint Louis, MO 63132
1-800-875-4788**

MADE IN USA

REVISION II
OCTOBER 2012



Intertek
Tested to the
UL391 Standard

FIRE CHIEF INDOOR FURNACE MANUAL

MODEL FC300F

SAVE THESE INSTRUCTIONS

Congratulations! You have selected the finest quality wood and coal burning indoor furnace, manufactured with pride in the USA. Please take a few moments to carefully read the owner's manual. By taking the time to familiarize yourself with your new Fire Chief Furnace, you will be able to look forward to years of trouble-free, dependable service.

Installation:

First: Check local codes. The installation must comply with all local rules and requirements.

Furnace installation is to be performed by a qualified installer. This furnace must not be installed in trailers, modular or mobile homes. Always have a properly installed and functioning smoke detector in your home. To prevent accidental injury, do not allow anyone who is unfamiliar with the furnace to operate it. Spend time familiarizing yourself with your Fire Chief Furnace, especially the different settings and the effects they have on burn patterns. It is impossible to predict how each setting will affect your furnace due to variations in conditions, fuels and temperatures.

Transportation Damage:

Every effort has been made to ensure that your Fire Chief Furnace will arrive in perfect condition. Any visible damage should be noted on the freight bill at the time of delivery. If upon unpacking your Fire Chief Furnace you find damage has occurred during transit, notify your dealer immediately. Your dealer will advise you what actions must be taken to address the problem.

Disclaimer Notice:

The listed BTU rating for your new Fire Chief Furnace was obtained using laboratory calculations. The actual BTU output you experience may vary somewhat depending on the type, condition and moisture content of the fuel used, damper adjustment, chimney type and other factors. Therefore, the manufacturer disclaims any guarantee as to the BTU output or capacity. Fire Chief Industries disclaims any responsibility for the following: installation of a furnace that has been altered or modified in any way; installation of the furnace other than as instructed in this manual; installation and/or use of any component or part not approved by Fire Chief Industries for use with this furnace. Be sure to complete and return your warranty card within 30 days of purchase in order to activate warranty coverage on your furnace.

Manufacturer's Notice:

Please be advised that we periodically make changes to improve our products, therefore the information in this manual may not be completely applicable to your Fire Chief Furnace. Please refer to markings on the appliance for additional information.

THIS IS A WOOD AND COAL BURNING FURNACE AND SHOULD NOT BE ALTERED IN ANY WAY.

TABLE OF CONTENTS

General Information	3
Location and Installation	3
Assembly of Unit	4
Blower and Housing	4
Optional Filter Box	5
Blower Assembly / Thermodisc	6
Chimney Types and Recommendations	7
Duct Runs	9
Installation of Optional Equipment	10
General Operation	11
Types of Wood to Use	11
First Wood Fire	12
Loading Wood	12
First Coal Fire	13
Disposal of Ashes	14
Creosote Formation	14
Creosote Prevention	14
Chimney Fire Warning	14
Power Failure	15
Furnace Diagram with Parts List	16
Grate System Diagram - FC300F	17
Blower Motor Assembly Diagram	17
Wiring Diagram	18
Troubleshooting	19
Warranty Information	24

DOUBLE CHECK TO MAKE SURE YOU HAVE RECEIVED ALL OF THE REQUIRED COMPONENTS. IF YOU FIND THAT THERE IS A PART MISSING, CALL 1-800-875-4788 FOR FASTEST SERVICE, PLEASE DO NOT GO BACK TO THE DEALER. DEALER DOES NOT HAVE REPLACEMENT PARTS.

General Information

The Fire Chief Furnace has been engineered to accommodate the heating requirements of the average sized home, even during winter's coldest months. It is constructed with high grade, heavy gauge steel and is continuously welded to assure the highest structural strength. In addition, the firebox is lined with firebrick to ensure many years of energy efficient service. The cast iron door is custom fitted to provide an airtight seal, greatly extending the burn time and ensuring maximum efficiency in fuel consumption. The heavy-gauge cast iron grate, designed for maximum heat transfer, allows for convenient ash removal and reduced maintenance.

Your Fire Chief Furnace is designed to be either a supplemental or central heating source for your home. This wood and coal burning furnace may be installed in parallel with a properly operating electric, gas or oil-fired central furnace, listed or certified in accordance with a nationally recognized safety standard, and within clearances specified on the nameplate. When in a parallel installation the static pressure of the central furnace plenum may not exceed 0.15 water column inches and the maximum setting on central furnace limit switch is 182°F. With the Fire Chief Furnace in an "Interconnection Arrangement" your furnace should be upstream of the central furnace. The Fire Chief Furnace warm air supply should never be connected to return air for the central furnace. A qualified installer should perform the installation.

IMPORTANT: FOR TECHNICAL SUPPORT OR CUSTOMER SERVICE ISSUES, DO NOT RETURN TO THE DEALER (THE DEALER DOES NOT HAVE REPLACEMENT PARTS), CALL 1-800-875-4788.

Forced Hot Air Circulation:

The plenum size of your Fire Chief Furnace must not be reduced to less than 12 inches in diameter or 113 square inches, and must provide a minimum of 18 inches between the top of your Fire Chief Furnace and the main trunk connection. The plenum attached to the furnace must be constructed of metal. The warm air supply duct system should be constructed of materials with a minimum temperature rating of 250° Fahrenheit.

Clearances:

Unit must be placed on a non-combustible floor. This floor must extend at least 16 inches in front, 8 inches on either side of fuel loading door and ash removal drawer, underneath the chimney connector and must extend 2 inches on either side of the chimney connector. The furnace must maintain the following clearances to combustibles:

- Heat plenum = 2 inches
- Chimney connector = 18 inches
- Front = 48 inches
- Rear = 31 inches
- Sides = 12 inches
- Main furnace = 12 inches

These are minimum clearances and should be strictly followed. In the case of a power outage, a dangerous level of heat accumulation may develop. Do not store fuel or other combustible materials within the above clearances.

Location and Installation

NOTE: Before beginning installation, consult proper local authorities regarding local codes governing all such applications and installations.

DO NOT CONNECT THIS UNIT TO A CHIMNEY FLUE SERVING ANOTHER APPLIANCE. Your furnace must be placed on a non-combustible floor. Position the furnace as close to the chimney as possible. Air for combustion must be provided into the room where the furnace is located. Allow air free access to the furnace for combustion and ventilation.

RECOMMENDATION: Purchase Chimfex™ Dry Chemical Chimney Fire Extinguisher. These are readily available at most stove shops and hardware stores. Smoke detectors should be installed on all levels of your home. Having a fire extinguisher in the furnace room or area is strongly recommended.

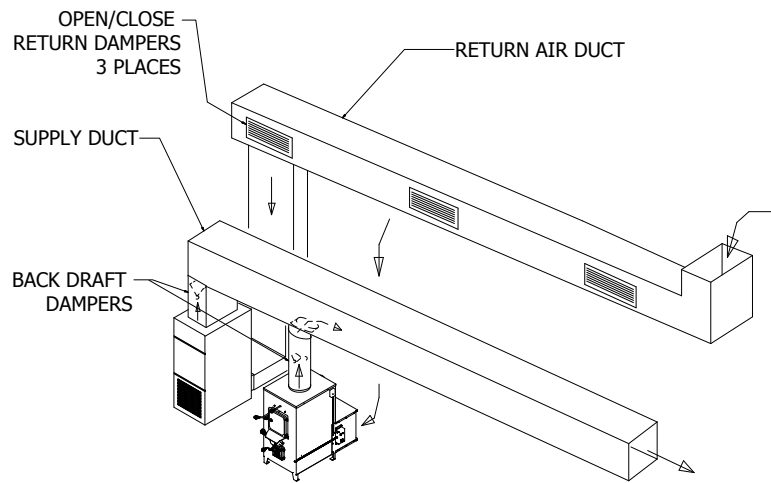

Assembly of Unit

Please review the parts list and diagrams contained on pages 16 - 18 of this manual.

DOUBLE CHECK TO MAKE SURE YOU HAVE RECEIVED ALL THE REQUIRED COMPONENTS. IF YOU FIND THAT THERE IS A PART MISSING, CALL 1-800-875-4788 FOR FASTEST SERVICE, PLEASE DO NOT GO BACK TO THE DEALER. DEALER DOES NOT CARRY REPLACEMENT PARTS.

1. Attach blower to the back of the furnace using (4) ¼ - 20 bolts and nuts. Line up the blower with the pre-drilled holes on the backside of the furnace, firmly attach with the bolts provided.

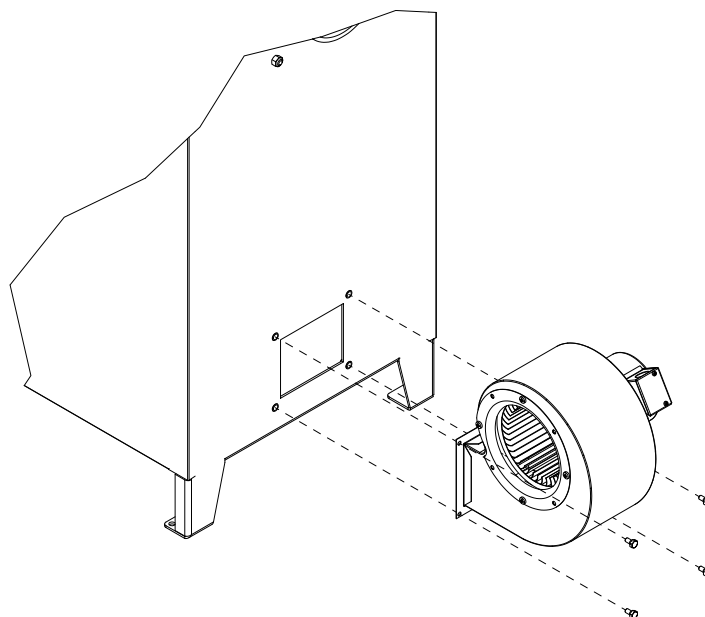

Optional Filter Box for FC300F:

The optional filter box may be added to your FC300F. With the addition of the filter box, the return air will be filtered before it passes through your furnace, eliminating dust and airborne dirt. Additionally, the life of the blower motor will be increased since the filtered air passing through the blower is cleaner. Replace your filter every thirty days during the heating season.

Filter Size: 16x20x1 - available at most hardware stores.

2. Assemble the following parts using 6 #10 sheet metal screws. Both "B" and "C" panels should fit inside of "D" and "A" panel flanges. Attach "D" (bottom panel) to "C" (side panel) and "B" (side panel with electric). After the top and sides are assembled, attach "A" (top panel) using 6 #10 sheet metal screws provided.

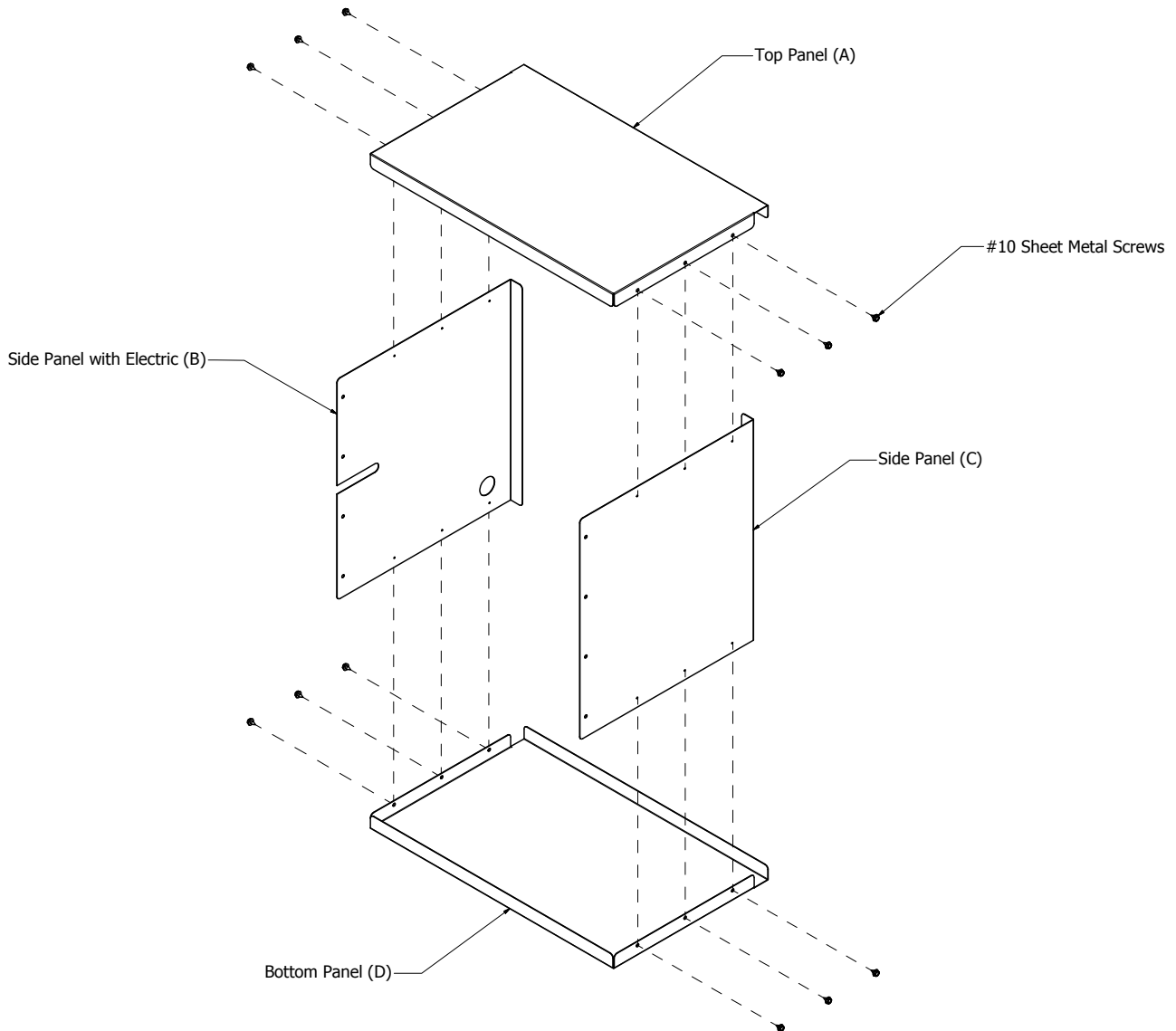

- Position the assembled filter box on rear of furnace, supporting it approximately 4 inches from the floor, covering the rear distribution blower. Make sure the filter box is tightly pressed to the back of the furnace. Use 8 #10 self-tapping screws (included) to firmly attach the filter box to the sides of the furnace.

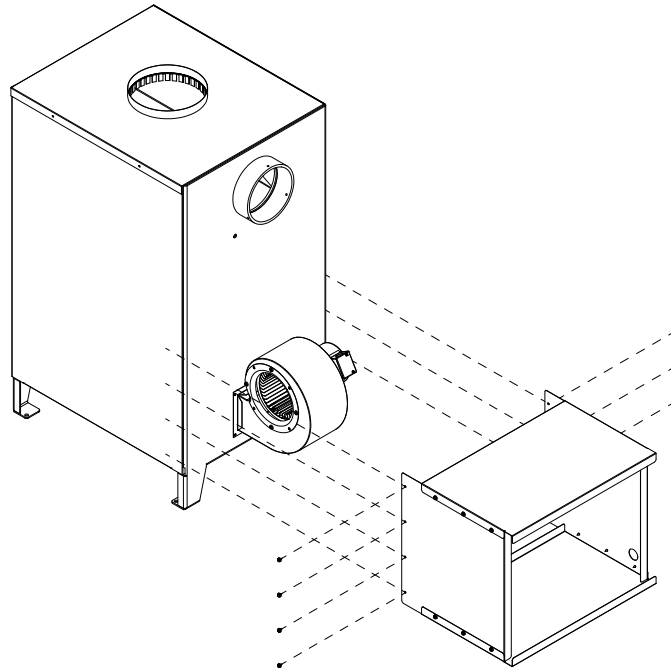

Installation of Blower Assembly

The FC300F blower assembly requires the following assembly to complete the installation on your furnace. The components are included with your furnace.

You should have the following items: blower motor with cord; four 1/4" x 20 x 3/4" bolts to attach motor to the back of the furnace; one thermidisc and two #8 x 1/2" screws; junction box with wiring and two #8 x 1/2" screws; cover plate with two screws. All are included with the furnace in a separate box along with the owner's manual and 8" starter collar.

- Bolt the motor onto the back of the furnace with the 4 1/4" x 20 x 3/4" bolts.
- Attach the thermidisc to the two diagonal holes on the left side of the furnace with the two #8 x 1/2" screws; attach one wire to each terminal on the thermidisc.
- Mount junction box in the two vertical holes on the left side of furnace with two #8 x 1/2" screws.
- Attach cover plate to junction box with the two attached screws.
- Plug electrical cord into outlet.

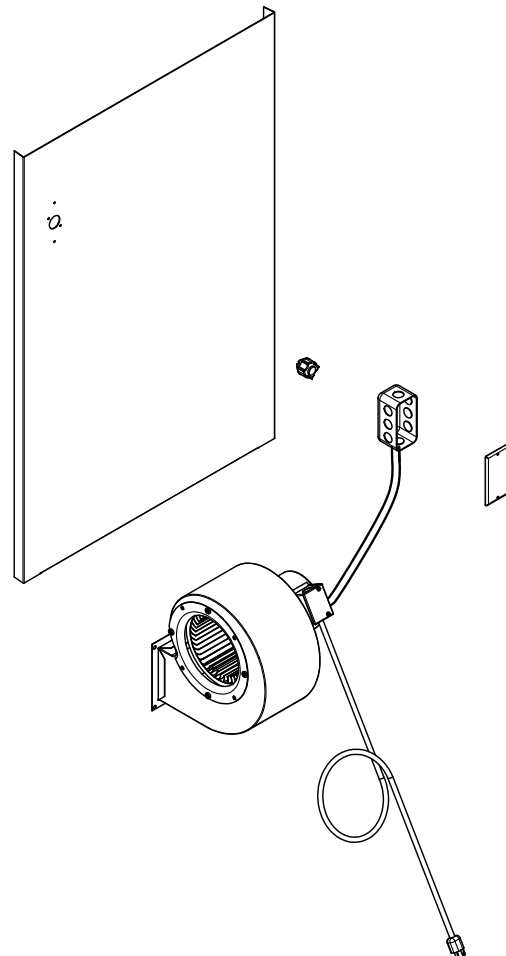

Chimney Types and Recommendations

See Diagram on page 8.

Safety requirements demand that your Fire Chief Furnace be connected to “Class A” HT2100 All Fuel, or stainless-lined masonry chimney ONLY.

By definition, “Class A” refers to either a lined masonry chimney or all fuel factory-built chimney. Although experts have expressed differing opinions as to which system is the best, it is a matter of what you find most suitable. Regardless of your choice of chimney type, for model FC300F, a minimum 6-inch diameter chimney is needed. In order to create the most effective draft, the chimney size should not exceed 12 inches, with a maximum .08 water column inches of draft. The flue draft can be measured with the use of a draft gage or manometer. If there is more than .08 water column inches of draft, it can be adjusted with the installation of a flue damper. The stovepipe required to connect the furnace to the chimney should be a minimum of 24 gauge black or stainless steel. NEVER USE GALVANIZED PIPE. Horizontal run should not exceed 5 feet and should have a minimum rise of 2 inches per foot. No installation should have more than 2 elbows, a 45° elbow is recommended over a 90° elbow.

As a safety precaution, all pipe selections should be fastened together with a minimum of 3 sheet metal screws. For your convenience, the crimped male ends of the pipe should point toward the furnace to form drip-free connections, thereby reducing the possibility of creosote leakage from the joints. Installing a heat reclaimer in the pipe is not recommended because it reduces the stack temperature thus causing creosote formation. Installing a manually operated cast iron damper in the stovepipe between the furnace and the chimney pipe is recommended. The addition of a damper will greatly assist in regulating the fire and achieving optimum results. Always install a tee with clean-out cap to the chimney outlet on the back of the furnace. This allows for easier cleaning of the chimney system. Never use a 90° elbow off the back of the furnace.

When using a masonry chimney, you must line the chimney with a stainless steel liner. The stainless steel liner will keep the chimney temperature hotter for better draw and significantly reduce the creosote formation in the chimney. If using this method, a 6-inch stainless liner should be used for model FC300F.

WARNING- RISK OF FIRE:

- Do not operate with flue draft exceeding .08 water column inches (19.9 Pa).
- Do not operate with fuel loading door or ash removal drawer open.
- Do not store fuel or other combustible materials within marked installation clearances.
- Inspect and clean flues and chimney regularly.

DANGER: Risk of Fire and Explosion. Do not burn garbage, gasoline, naphtha, engine oil, or other flammable liquids/inappropriate materials.

WARNING:

- NEVER use galvanized pipe in your chimney connection, it produces poisonous gases when subjected to extreme temperatures.
- USE only lined masonry or manufactured Class “A” HT2100 All Fuel Chimney for your furnace.
- INSPECT chimney system periodically for structural integrity.
- CLEAN the chimney system regularly to prevent creosote accumulation.
- DO NOT CONNECT THIS UNIT TO A CHIMNEY FLUE SERVING ANOTHER APPLIANCE.

For the best draw the chimney termination should be at least 2 feet above the highest portion of the roof that is within a 10 foot radius of the chimney.

The termination cap should be designed to inhibit down-drafting without restricting the exhaust discharge.

USE LISTED UL 103 TYPE HT 2100 CHIMNEY ONLY.

When using a brick chimney, you must line the entire chimney with stainless steel liner. The liner must be the correct size for the furnace. (FC300F: 6 inch liner)

The diameter of the chimney stack should be consistent throughout length of the chimney

The chimney size should be at least as large as the exhaust stack on the furnace, but not more than twice its size.

The chimney stack should have a built in airtight clean out.
WARNING: Do not operate with clean out uncapped.

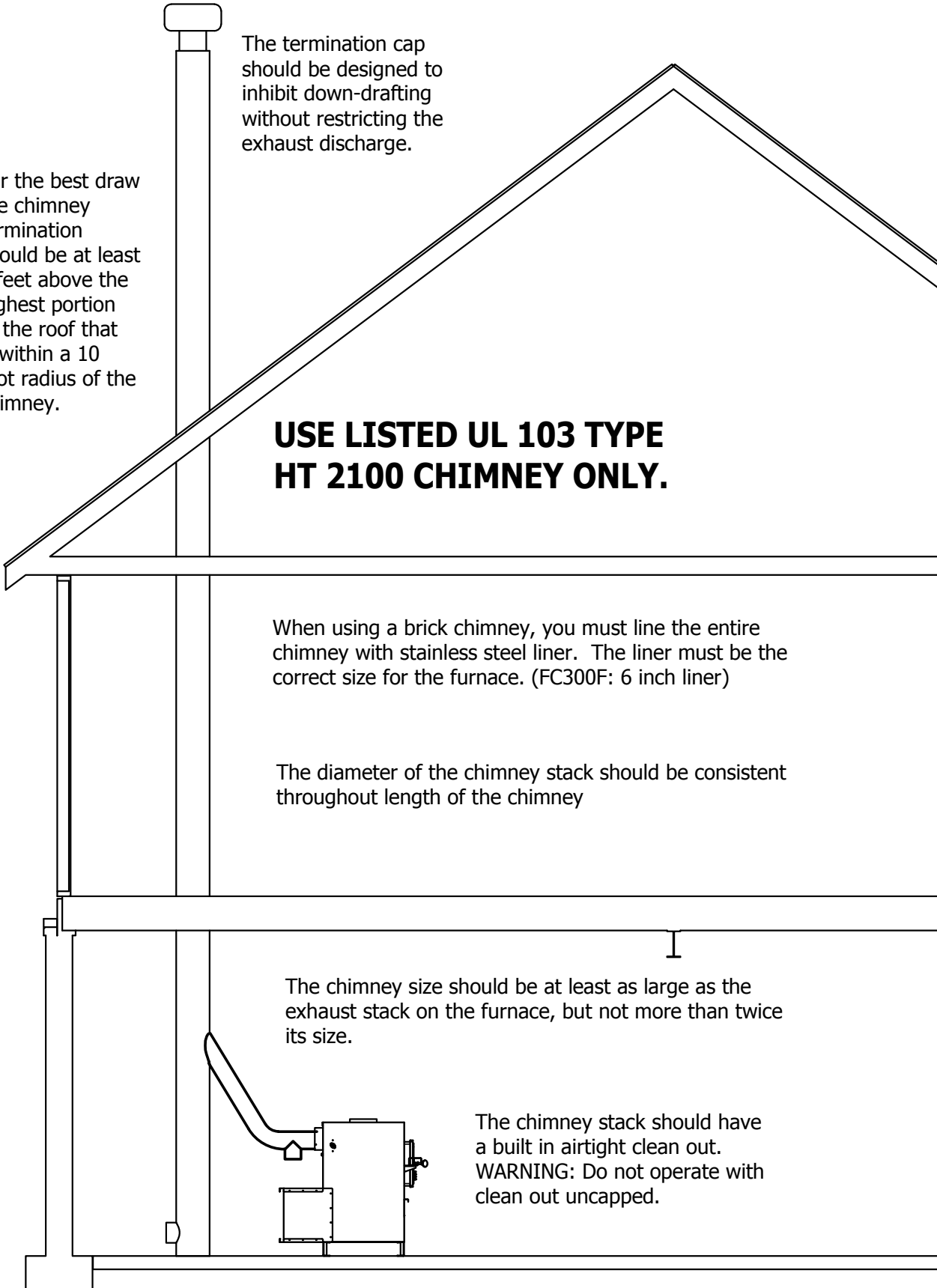

Duct Runs

Ductwork should be designed so the external static pressure does not exceed .02 water column inches while developing air velocities of 450 - 600 feet per minute at the registers. The heat outlet area should never be less than 12 inches round or 113 square inches. The furnace can be installed with a cold air return system, or the return air can be drawn from the basement. If the return air is drawn from the basement, you will have to install 3 "open and close" air register vents in the return air duct connected to your existing furnace; the air will take the path of least resistance without using ductwork to connect the two together. The return air system should be a minimum of 10% larger than the heat outlet to readily transfer the cold air back to the furnace. Avoid using 90° elbows in duct runs; 45° elbows provide better airflow and less resistance. CAUTION: The warm air supply outlet of the supplementary furnace should not be connected to the cold air return inlet of the central furnace, because a possibility exists for components to overheat and cause the central furnace to operate other than intended.

Canadian Requirements for Supplemental/Add-On Furnaces

- DO NOT USE DUCT ELBOWS HAVING AN INSIDE RADIUS OF LESS THAN 6 inches (150mm) ON OIL, ELECTRIC, OR GAS FURNACES.
- DO NOT CONNECT TO A DOWNFLOW FURNACE.
- DO NOT CONNECT DUCTWORK SO THAT A REVERSE FLOW IS POSSIBLE.
- OPERATE THE GAS/OIL/ELECTRIC/ FURNACE PERIODICALLY TO ENSURE THAT IT WILL OPERATE SATISFACTORILY WHEN NEEDED.
- CERTIFIED FOR INSTALLATION WITH APPROPRIATE DUCTWORK CONFIGURATIONS ONLY.
- DO NOT RELOCATE OR BYPASS ANY OF THE SAFETY CONTROLS IN THE ORIGINAL GAS/OIL/ELECTRIC FURNACE INSTALLATION.
- DO NOT CONNECT TO ANY GAS FURNACE THAT HAS NOT BEEN CERTIFIED INITIALLY AS COMPLYING WITH CAN/CGA-2.3.
- THE OPERATION OF THE GAS FURNACE MUST BE VERIFIED FOR ACCEPTABLE OPERATION BEFORE AND AFTER INSTALLATION OF THE ADD-ON APPLIANCE BY A GAS FITTER WHO IS RECOGNIZED BY THE REGULATORY AUTHORITY.
- DO NOT CONNECT TO ANY GAS FURNACE THAT IS NOT EQUIPPED WITH AN AIR-CIRCULATION BLOWER, OR TO A CHIMNEY OR VENT SERVICING A GAS FURNACE OR GAS APPLIANCE.

The add-on unit should only be installed on a furnace duct system and chimney that are in good operating condition.

On a belt-driven system, blower and motor pulleys may be changed but the electrical current flowing through the motor cannot exceed the nameplate rating. On a direct-drive system, the motor should not be changed, however, the speed of the motor may be increased. The blower cannot be changed. This equipment should be installed, acceptable to regulatory authority, by experienced licensed personnel.

The installation should comply with requirements of CAN/CSA-B365, and changes to the installation should comply with CSA-B139 (for oil-fired), C22.1 (for electric), or CAN/CGA-B149.1 or CAN/CGA-B149.2 (for gas-fired).

IMPORTANT: FOR TECHNICAL SUPPORT OR CUSTOMER SERVICE ISSUES, DO NOT RETURN TO THE DEALER (THE DEALER DOES NOT HAVE REPLACEMENT PARTS), CALL 1-800-875-4788.

BURN WOOD AND COAL ONLY!

Installation of Optional Equipment

Back Draft Damper:

OPTIONAL ACCESSORY PART #AM-BD8 Back Draft Damper

The Back Draft Damper may be installed in either a vertical or horizontal section of the 8" round hot air duct. It should be positioned as close to the plenum opening of the FC300F as practical. Press the female end of the damper over the FC300F furnace collar or male end of the duct pipe. When properly positioned, the arrows on the air flow decal point "away" from the FC300F.

NOTE: The back draft damper may cause the blower to cycle on and off frequently. If this occurs, install a sheet metal screw inside of the damper to prevent the flapper from closing completely. This will allow heat to rise off the furnace.

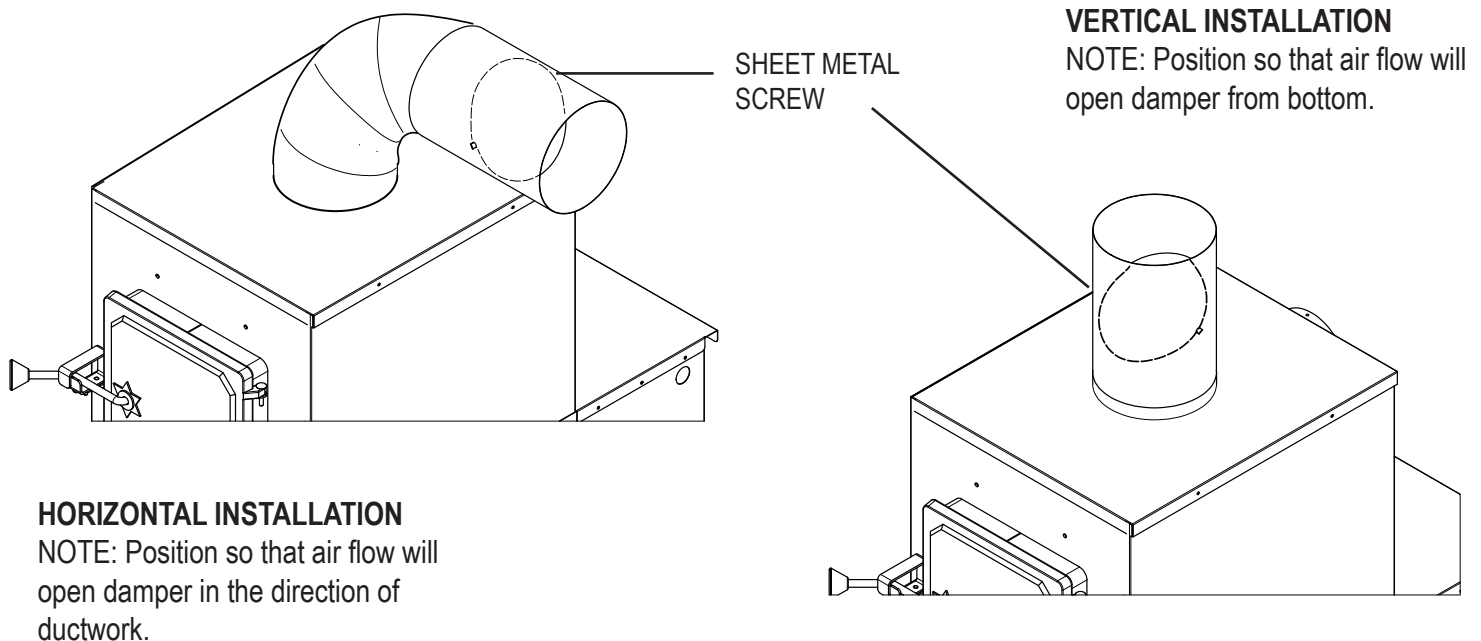

Manual Back Draft Damper:

OPTIONAL ACCESSORY PART #AM-MD8 Manual Back Draft Damper

The Back Draft Damper may be installed in either a vertical or horizontal section of the 8" round hot air duct. It should be positioned as close to the plenum opening of the FC300F as practical. Press the female end of the damper over the FC300F furnace collar or male end of the duct pipe. When properly positioned, the arrows on the air flow decal point "away" from the FC300F.

NOTE: The back draft damper handle closes off the duct, stopping the cool air from your air-conditioner from flowing back through the furnace. Diagrams above show horizontal and vertical installation. OPEN THE DAMPER AT THE BEGINNING OF HEATING SEASON - IF THE DAMPER IS IN THE "CLOSED" POSITION, IT WILL CAUSE THE BLOWER TO RUN CONTINUOUSLY AND CAUSE THE FURNACE TO OVERHEAT CAUSING THE BLOWER TO FAIL.

BURN WOOD AND COAL ONLY!

General Operation

Types of Wood to Use:

We advise using only dry, seasoned hardwoods in your Fire Chief Furnace rather than high resin woods such as pine. Firewood should be cut at least one full season prior to the time of its intended use, for optimum heat output. Firewood should be stacked to provide a free flow of air between the logs, thus allowing more rapid seasoning of the wood. If wood is stored outdoors, it should be completely covered year round to protect it from moisture and exposure to the elements.

FUEL RECOMMENDATIONS:

- FC300F – 22 inch maximum log length

Use extreme caution when opening the door during operation, temperatures can exceed 300°F. Wait at least 10 seconds after releasing the latch, and then proceed to the fully open position. Opening the door in this manner is designed to eliminate the possibility of gaseous ignition. Heat resistant gloves are recommended when opening the fuel door, regulating the spin draft, or emptying the ash pan.

CAUTION: HOT SURFACES. KEEP CHILDREN AWAY. DO NOT TOUCH DURING OPERATION.

CAUTION:

- INSPECT FLUE PIPES, JOINTS AND SEALS REGULARLY TO ENSURE THAT SMOKE AND FLUE GASES ARE NOT DRAWING INTO, AND ARE NOT BEING CIRCULATED BY THE AIR-CIRCULATION SYSTEM.
- CLEANING OF THE HEAT EXCHANGER, FLUE PIPE, CHIMNEY AND DRAFT INDUCER (IF USED), IS ESPECIALLY IMPORTANT AT THE END OF THE HEATING SEASON TO MINIMIZE CORROSION DURING THE SUMMER MONTHS CAUSED BY THE ACCUMULATED ASH.
- Never use chemicals or gasoline to start or maintain your fire.
- Do not burn oil, garbage, trash, plastic, or any fuel other than wood or coal in your furnace. Doing so will void the warranty.

WARNING: – RISK OF FIRE

- DO NOT operate with flue draft exceeding .08 water column inches (19.9 Pa).
- DO NOT store fuel or other combustible materials within marked installation clearances.
- Inspect and clean flues and chimney regularly.
- DO NOT operate your furnace with the fuel door or ash drawer open.

WARNING: NEVER fuel your furnace with wet, unseasoned wood or wood that has been exposed to a recent rainfall. Burning wood with high moisture content will cause a rapid accumulation of hazardous creosote, which has been proven to be the most common cause of flue fires. NEVER burn plastics, any wood product containing glue, or wood treated with chemical preservatives in your furnace. The combustion of these substances may release harmful, toxic gases.

DANGER: RISK OF FIRE OR EXPLOSION – do not burn garbage, gasoline, naphtha, engine oil, or other flammable liquids/inappropriate materials.

Supplemental Outside Combustion air may be necessary if:

- The solid-fuel-fired appliance does not draw steadily, smells, experiences smoke rollout, burns poorly, or back-drafts whether or not there is combustion present. Opening a window slightly on a calm day may alleviate these symptoms.
- The house is equipped with a well-sealed vapor barrier and tight fitting windows, and/or has any powered devices which exhaust house air.
- There is excessive condensation on windows in the winter.
- A ventilation system is installed in the house.

BURN WOOD AND COAL ONLY!

First Wood Fire:

Place several crumpled newspapers on the grate with some dry kindling layered on top of the papers, then ignite the newspaper. When the kindling is burning, add several small pieces of wood, allow wood to fully ignite. After about 20 minutes the fire should be established, allowing you to add more wood – do not overload which would smother the fire. Add more wood slowly, so the flames have time to engulf the fresh wood. Once the fire is burning and there is a glowing ember bed, adjust the draft to achieve desired burn pattern. Learning how to adjust the draft to maintain the desired temperature for your home may take several days. After a short time you will know which settings and adjustments work best for your home.

Do not over-fire the furnace. Over-firing by overloading/over fueling the furnace causes the metal to superheat and expand, then cool rapidly, which causes cracking, therefore voiding the warranty. Over-firing or abuse can easily be determined upon inspection.

It will take about 40 minutes to establish a bed of hot embers. Once you have achieved the hot ember bed, add larger pieces of firewood. Within 30 to 40 minutes, adjust the spin draft and the damper to obtain optimum performance.

NOTE: Your new Fire Chief Furnace is capable of producing a very high BTU output. Do not fuel your furnace to capacity upon initial firing. It's recommended that you become thoroughly familiar with your Fire Chief Furnace before operating at full capacity. The new steel and metal components of the furnace have a protective coating or paint on the surface which could produce an odor during the break in period. Adequate ventilation within the home and furnace room or area is recommended during the initial firing and break in period to accommodate this possibility. Your new Fire Chief Furnace is classified as having airtight construction. This type of design should enable you to experience an average burn time between 6 and 8 hours per full load of fuel (dry, seasoned hardwood). However, abnormally cold weather may reduce the burn time somewhat, but if your burn cycle is significantly less, for instance, 2 to 4 hours, you are over-firing your furnace. This type of occurrence is usually symptomatic of heat demands in excess of furnace capacity. Contact an authorized professional to determine if your Fire Chief Furnace has been improperly sized for your home.

Loading Wood:

When opening the fuel door during operation, wait 10 seconds after releasing the first latch, then open the door the rest of the way. The dual latch system has been incorporated as a safety feature, designed to eliminate the possibility of gaseous ignition. Laboratory testing has determined that when incomplete combustion occurs the partially spent fuel sometimes concentrates large amounts of potentially hazardous gases within the fire chamber. If the door is opened suddenly under these conditions, the oxygen may combine with these gases and cause ignition referred to as "back flash." Use EXTREME CAUTION when opening the fuel door.

When reloading the furnace, spread embers evenly over the grate. Place smaller pieces of wood or coal on the hot embers and layer larger pieces on top of them. Finally, due to the wide variety of temperature ranges during the winter, you may experience periods when it is not necessary to fully load the fire chamber in order to maintain an overnight burn. Your Fire Chief Furnace will operate at the highest efficiency by adding fuel in amounts needed to maintain comfortable temperatures in your home.

Starting the First Coal Fire:

Burning coal is much harder than burning wood. There is more care and work in building and maintaining a coal fire than a wood fire. Anthracite is the best coal to burn, due to its long even burn with higher heat output and clean burn quality but is more difficult to manage than Bituminous coal.

The size of coal is important. "Nut" coal sizes of 4 inches for Bituminous and 2¾ to 4½ inches for Anthracite coal are recommended. Never use coal other than the sizes recommended. If the coal is too small it will smother the fire and if it is too large the coal will not burn well.

When burning Bituminous coal, start the fire with wood (as described above). Always use dry kindling, as this will provide a hotter fire and add small pieces of wood until you get a good hot ember bed. At this point add a small amount of coal. When the coal is hot enough to ignite, add small amounts at a time, so as not to smother the fire. Keep in mind that Bituminous coal will require more maintenance as this type of coal will produce more soot, requiring more frequent cleaning to prevent buildup.

Also make sure that the spin draft is wide open to establish the correct burn pattern. When adding coal to Bituminous fires always add coal to the center of the bed creating the cone effect. Bituminous coal is more volatile and adding coal to the center of the bed causes the flames to drive off the volatile gases. Remember that no two installations and chimney set-ups are the same, so be prepared to experiment until you achieve the desired results. Always allow enough air to the firebox and keep the damper open so that volatile gases are properly burned. When adding fuel, remember to break up the cone with a poker if it has formed a crust, but be careful to avoid mixing the coal as this can form clinkers. For overnight burn operations, follow the above instructions and adjust the chimney damper.

When burning Anthracite coal, start the fire with wood (as described above). Add layers of coal making sure not to smother the fire, the third layer should be a little heavier, but **should not to extend above 2 inches below the top of the brick in the firebox**. Before adding more fuel, be sure to leave a red spot in the center of the bed. This hot spot will help ignite the gases given off the new charge. A deep charge will give a more even heat and a longer fire. It may take up to a couple hours before the whole bed is fully ignited. When the fire is established and the home is becoming warm, you may adjust the damper. It may still take some experimenting to ensure proper operation, as no two installations are the same. Once the coal bed has reduced to half its original depth it is time to add fuel to the furnace. Open the fuel door, using a small rake or hoe pull the coals towards the front of the bed, trying not to disturb the fire too much. Next, add coal to the back, being careful not to seal off the top. Keep the ash pan cleaned out to ensure good airflow. You may want to start this banking process early in the evening before retiring or before leaving the home so that you may make proper adjustments after the fire is well established.

WARNING: It is unsafe to load any type of coal within 2 inches of the top of the firebrick. Load fuel carefully or damage may result.

NOTE: Do not burn coke, charcoal, highly volatile Bituminous coal, sub Bituminous, lignite or cannel coal (sometimes called channel coal or candle coal). Never burn chemically processed logs, such as fire logs, as their use is intended for fireplaces only. Please follow all guidelines in this manual concerning wood and coal burning applications due to safety concerns and to maintain warranty coverage.

BURN WOOD AND COAL ONLY!

Disposal of Ashes:

Heat resistant gloves are recommended. In order to remove ashes from your Fire Chief Furnace, remove the ash pan from the furnace and dump the ashes into a metal container with a tight fitting lid. The closed container of ashes should be placed on a non-combustible floor or on the ground, well away from all combustible materials, pending final disposal. If the ashes are disposed of by burial in soil or otherwise locally dispersed, they should be retained in the closed metal container until all cinders have thoroughly cooled.

Remove the ashes from your Fire Chief Furnace at least once a day, or as often as necessary to ensure the ashes do not accumulate to the height of the grates. If ash build-up occurs at grate level, it will cause premature failure of the grate system, voiding the warranty on the grates. Unacceptably high temperatures will result because the ashes have restricted the flow of cooling air beneath the grates. This flow of air was designed to not only cool the grates, but to also provide warmed air for better combustion. If the ash level is improperly maintained the firebox will be starved of combustion air, greatly reducing the efficiency and heat output of your Fire Chief Furnace.

CAUTION: HOT SURFACES. KEEP CHILDREN AWAY. DO NOT TOUCH DURING OPERATION.

IMPORTANT: FOR TECHNICAL SUPPORT OR CUSTOMER SERVICE ISSUES, DO NOT RETURN TO THE DEALER (THE DEALER DOES NOT HAVE REPLACEMENT PARTS), CALL 1-800-875-4788.

Creosote Formation and Need for Removal:

When wood is burned slowly, it produces compounds in exhaust smoke which combine with expelled moisture to form creosote. The creosote vapors condense in the relatively cooled chimney flue of a slow burning fire. As a result, creosote residue accumulates on the flue lining. When ignited, this creosote makes an extremely dangerous fire in the chimney. The chimney connector and the chimney should be inspected at least twice monthly during the heating season to determine if a creosote build-up has occurred. If creosote has accumulated it should be removed to reduce risk of a chimney fire.

Creosote Prevention:

To help reduce the formation of creosote within the flue, ALWAYS BURN DRY, SEASONED WOOD. Dry wood burns hotter, allowing flue gases to maintain temperatures above 212°F which should reduce the quantity of creosote in the chimney. If the flue gas temperature falls below 212°F, condensation occurs causing creosote formation and accumulation within the chimney.

As an added precaution, periodic chimney inspections are recommended during the heating season to determine if creosote formation has occurred. For safety and efficiency, it is recommended that the chimney system be inspected and cleaned prior to each heating season.

Chimney Fire Warning:

In the event of a chimney fire, take the following actions immediately:

- Activate and toss a Chimfex™ Dry Chemical Chimney Fire Extinguisher into the firebox.
- Close the ash drawer, fuel door and spin drafts.
- Alert entire household and prepare to evacuate if necessary.
- Call your local fire department.

Power Failure:

In case of power failure, to prevent your Fire Chief Furnace from over-heating and causing damage to the electrical components, do NOT add more fuel (coal or wood) to the firebox.

There is no warranty on electrical components damaged due to power failure.

NOTE: OVER-FIRING OR DELIBERATE ABUSE CAN EASILY BE DETERMINED UPON INSPECTION AND WILL VOID THE WARRANTY.

Always keep your wood covered year round. Dry wood will produce higher BTU output and a longer burn time. Refer to the nameplate on furnace for additional information.

WARNING: RISK OF FIRE

- Do not operate with the flue draft exceeding .08 water column inches (19.9 Pa).
- Do not operate with fuel loading door or ash removal drawer open.
- Do not store fuel or other combustible material within marked installation clearances.
- Inspect and clean flues and chimney regularly.

THIS IS A WOOD AND COAL BURNING FURNACE ONLY AND SHOULD NOT BE ALTERED IN ANY WAY.

Furnace Diagram

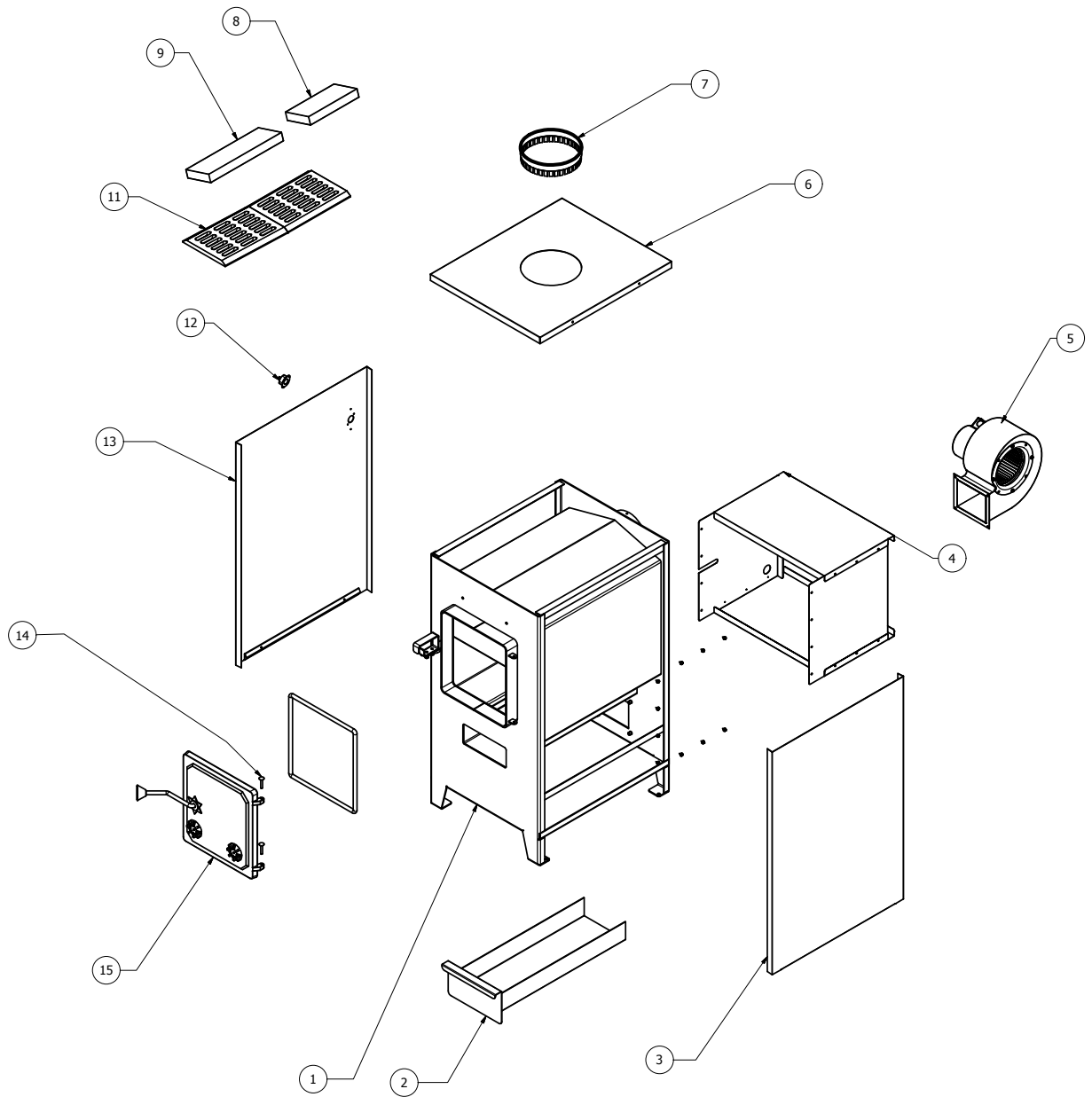

PARTS LIST			
ITEM	QTY	DESCRIPTION	ITEM NUMBERS
1	1	FURNACE SHELL	FC3 SHELL
2	1	ASH PAN	FC3AP
3	1	RIGHT HAND SKIN	FC3RH
4	1	FILTER BOX	FCFB3
5	1	FURNACE BLOWER	FC300 BM
6	1	TOP SKIN	FC3TOP
7	1	DUCT CONNECTOR	FC8C
8	2	BRICK' 9" LONG	HTFB
9	2	BRICK, 13-1/2" LONG	FC11041
11	1	WOOD GRADE GRATE	FCWG
12	1	THERMO DISCONNECT SWITCH	FCTD110
13	1	LEFT HAND SKIN	FC3LH
14	2	DOOR HINGE PIN	FCDP
15	1	FUEL DOOR ASSEMBLY	FCFD3A

Grate System Diagram - FC300F

PARTS LIST		
ITEM	QTY	DESCRIPTION
1	2	GRATE
2	2	BRICK-13.5 INCHES LONG
3	2	BRICK-9 INCHES LONG

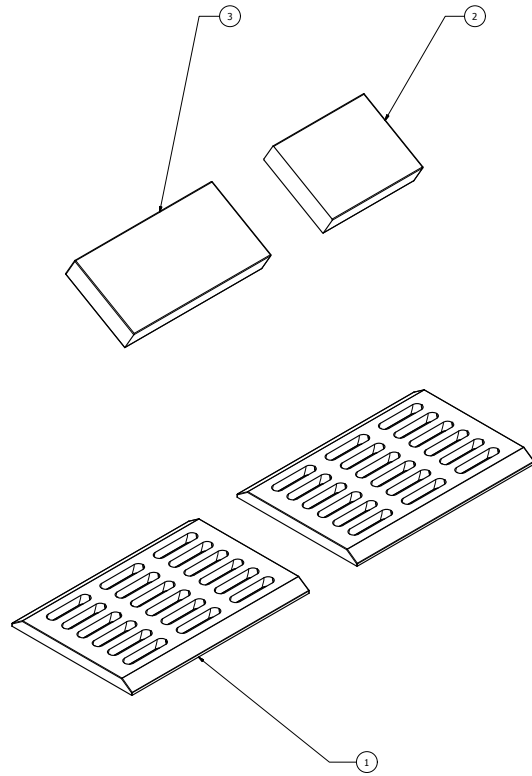

Blower Motor Assembly Diagram

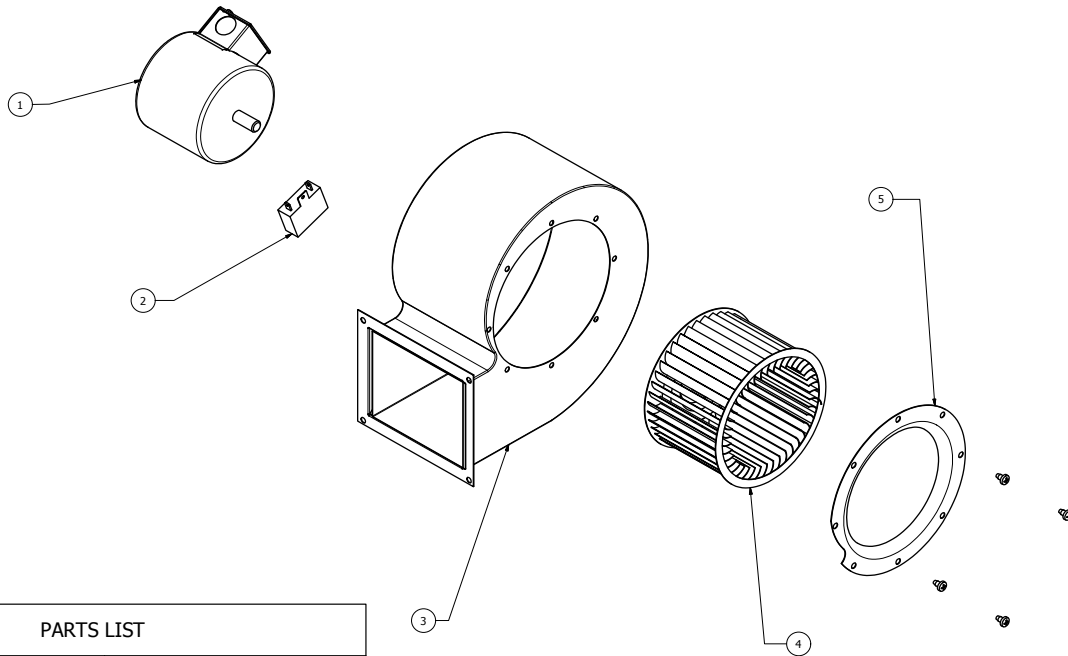

PARTS LIST		
ITEM	QTY	DESCRIPTION
3	1	BLOWER HOUSING
1	1	BLOWER MOTOR
4	1	BLOWER WHEEL
5	1	INLET COLLAR
2	1	MOTOR CAPACITOR

Wiring Diagram

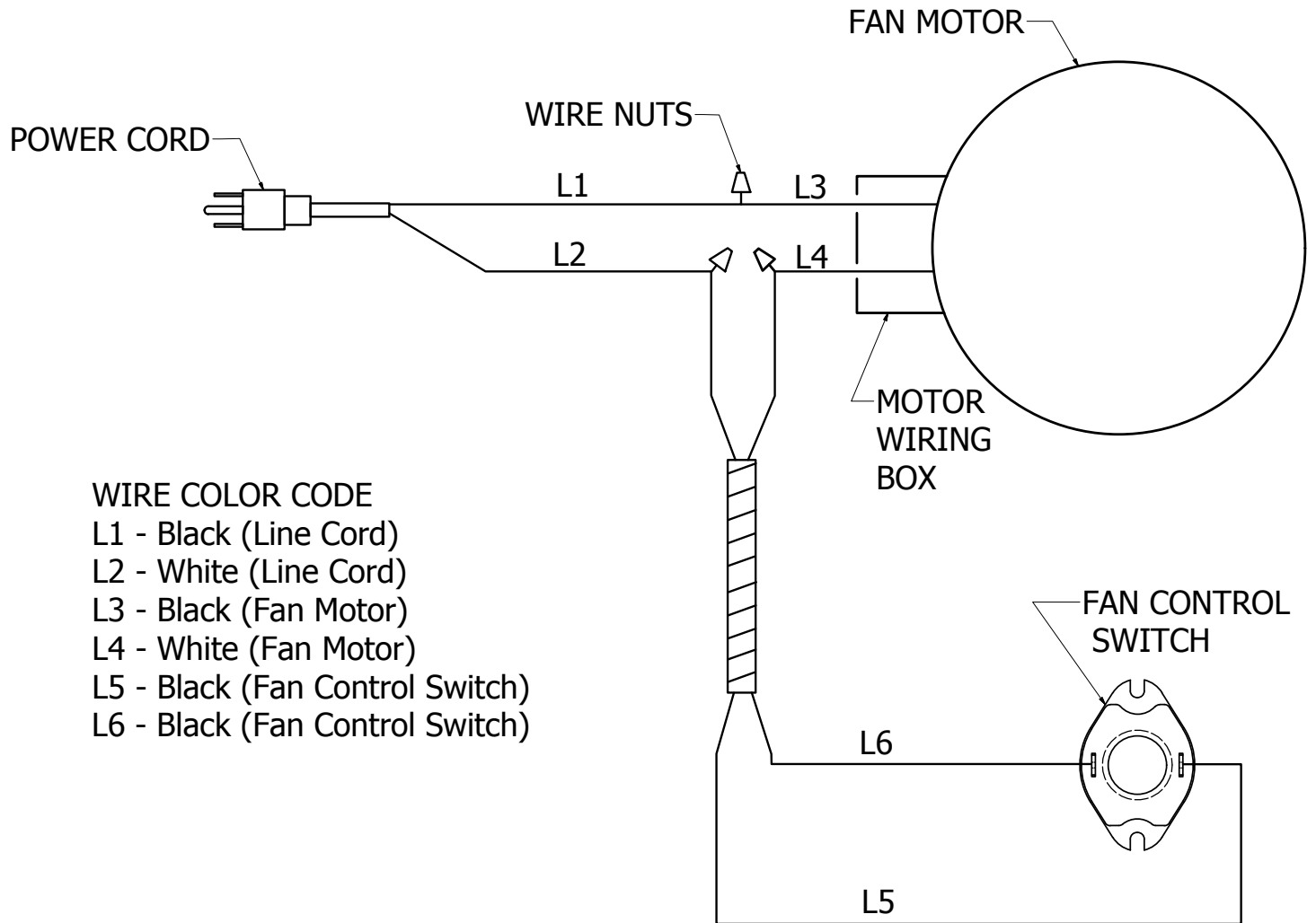

Troubleshooting

1. Problem: Circulation blower will not turn on.

Possible Causes:

- Defective fan thermodisc switch.
- Defective motor.
- Improper wiring.

Remedies:

- If the blower fails to run, replace the fan thermodisc switch.
- Contact your supplier for replacement.
- Review wiring diagram. If wired correctly, seek professional assistance.

2. Problem: Circulation blower runs continuously.

- Damper in closed position.
- Improper wiring.

- Open backdraft damper.
- Review wiring diagram. If wired correctly, seek professional assistance.

3. Problem: Circulation blower vibrates during operation.

Possible Causes:

- Screw on squirrel cage is not tight.
- Balance weights on squirrel cage have become dislocated.
- Defective main bearings.

Remedies:

- Check squirrel cage alignment and position so that it does not drag on the housing during rotation, then tighten the screw sufficiently to fasten the squirrel cage securely to the shaft.
- You may attempt to adjust the weights yourself to obtain an acceptable balance. If you are unsuccessful, contact your supplier.
- Return the blower to your supplier for replacement.

4. Problem: Odor detected in home during initial firing.

Possible Causes:

- There is an oily film that remains on the steel after the manufacturing process. Firing the furnace has raised the temperature of the fire box to a level that is sufficient to vaporize the residue.

Remedies:

- The odor should disappear after a few hours of usage.

5. Problem: Excessive dirt accumulation surrounding air registers in the home.

Possible Causes:

- Smoke discharge from loading door while refueling.
- Furnace is not connected to return air duct and is drawing dirt from furnace room floor and disbursing it throughout home.
- Filter box not installed, or no filter in filter box.

Remedies:

- Insufficient draft, see #10.
- Connect to return air duct system.
- Install filter box on furnace. Install filter in filter box.

6. Problem: Smoke from the fire chamber is puffing back through the ash drawer.

Possible Causes:

- Furnace is not connected to return air and is drawing smoke fumes from the flue.
- Excessively long run of stove pipe from furnace to flue.
- Too many elbows.
- Insufficient flue size.

Remedies:

- Connect to return air duct system. Or room may be too airtight, refer to "Location and Installation" section on page 3.
- Relocate the furnace so the horizontal run does not exceed 5 feet and has a 2 inch rise per foot.
- The run should not contain more than 2 elbows.
- Replace with a larger flue providing a minimum of 50 square inches but not more than 100 square inches of draft area. If the flue is within these specifications, check the draft with a draft gage (manometer). Your flue should provide a minimum of .04 water column inches and a maximum of .08 water column inches.

7. Problem: Flames discharging from fuel door during reloading.

Possible Causes:

- Opening the door has provided additional oxygen which has ignited the accumulated gases from partially spent fuel.
- Cast iron damper in the "CLOSED" position.
- Insufficient natural draft or an obstruction in the flue system.
- Fire chamber filled to capacity with unburned fuel.

Remedies:

- Always open the door cautiously and allow the safety latch system to perform its designed function, containing gases within the fire chamber.
- Open damper.
- See #9 and #10.
- Do not attempt to overload the furnace.

8. Problem: Rapid accumulation of creosote in furnace and flue.

Possible Causes:

Remedies:

- | | |
|--|--|
| <ul style="list-style-type: none">• Use of high resin wood, such as pine. | <ul style="list-style-type: none">• Completely avoid using if at all possible. |
| <ul style="list-style-type: none">• Under-firing the furnace has caused low flue gas temperature. | <ul style="list-style-type: none">• Install flue gas thermometer and maintain stack temperatures between 300° and 400° F. |
| <ul style="list-style-type: none">• Insufficient chimney draft. | <ul style="list-style-type: none">• See #10. |
| <ul style="list-style-type: none">• Using uninsulated stove pipe for the chimney, especially if the construction is on the exterior of the home. | <ul style="list-style-type: none">• DANGER: Never use uninsulated stove pipe as chimney. It must not be used on the inside of your home due to high stack temperatures, which create an extreme fire hazard. Uninsulated pipe cannot be used as an outside flue because it causes rapid cooling of the stack gases, which causes them to condense as creosote on the inside of the flue. |
| <ul style="list-style-type: none">• Improper connection in stove pipe causing air leakage or a structural defect in the chimney itself. | <ul style="list-style-type: none">• Inspect entire flue run, from the exhaust stack of the furnace to the termination cap. Repair as necessary. |
| <ul style="list-style-type: none">• Fire box not receiving adequate amount of oxygen. | <ul style="list-style-type: none">• Furnace room may be too airtight to supply sufficient amount of oxygen for combustion. Install an aperture to the outside consisting of a minimum of 12 square inches or 4 inches round. |
| <ul style="list-style-type: none">• Use of an unlined masonry chimney with a large clay tile opening. | <ul style="list-style-type: none">• Install stainless steel liner in masonry chimney to reduce creosote formation and improve draw. Use appropriate size stainless liner for the furnace. |

9. Problem: Excessive smoke discharge from fuel door during reloading.

Possible Causes:

Remedies:

- | | |
|--|--|
| <ul style="list-style-type: none">• Cast iron damper in the "CLOSED" position. | <ul style="list-style-type: none">• Open damper. |
| <ul style="list-style-type: none">• Excessively long stove pipe run from furnace flue. | <ul style="list-style-type: none">• See #6. |
| <ul style="list-style-type: none">• Too many elbows. | <ul style="list-style-type: none">• See #6. |
| <ul style="list-style-type: none">• Insufficient draft. | <ul style="list-style-type: none">• See #6. |
| <ul style="list-style-type: none">• Excessive smoke accumulation. | <ul style="list-style-type: none">• See #10. |

10. Problem: Down draft on chimney caused by one or more of the following.

Possible Causes:

- Cast iron damper in “CLOSED” position.
- Flue has a cold spot which inhibits exhaust discharge from rising properly.
- There is an obstruction outside chimney, such as a tree.
- Flue is located too close to the peak of the roof or does not rise above it to provide the proper draft.
- Backdraft damper is in the “closed” position.

Remedies:

- Open damper.
- This problem may occur in factory built flues because the insulation has settled or a seam has ruptured. In masonry flues, mortar loss may be causing seepage of cooler outside air into the stack. Check entire flue for structural integrity and leakage. Correct or repair as needed, or replace or re-line the chimney.
- Remove obstruction.
- Increase chimney height.
- Open backdraft damper.

11. Problem: Circulation blower will not turn on.

Possible Causes:

- Improper wiring.
- Defective capacitor.
- Defective blower.

Remedies:

- Review wiring diagram. If wired correctly, seek professional assistance.
- Replace capacitor.
- Contact your supplier for replacement.

12. Problem: Bugs found in wood.

Possible Causes:

- Wood has rotted or has been laying around for an extended period of time.

Remedies:

- Inspect the wood for obvious signs of insect infestation such as burrows or holes, avoid using if possible. Do not store wood indoors.

13. Problem: Home does not achieve comfortable temperature.

Possible Causes:

Remedies:

- Improper ductwork connection to existing furnace.

- Refer to information in the manual relating to the proper installation procedures or contact your local heating and cooling contractor.

- Improperly sized ducting.

- Refer to information in the manual relating to the proper ducting procedures or consult your local heating and cooling contractor.

- Excessive dirt accumulation in optional air filter.

- Check and replace filter. Proper filter size is 16" by 20" by 1."

- Combustion chamber not receiving an adequate amount of oxygen.

- Furnace room may be too airtight. Install an aperture to the outside consisting of a minimum of 12 square inches or 4 inches round.

- Furnace size is inadequate for your home.

- Consult a professional to determine correct sizing.

- Fueling furnace with wet or unseasoned wood.

- Completely avoid using if at all possible.

Warranty Information

CERTIFICATE OF LIMITED WARRANTY:

EXTENT OF COVERAGE: This warranty covers any Fire Chief Furnace FC300F sold in the United States and Canada. This warranty applies only if the Fire Chief Furnace is installed, maintained, and operated in accordance with the instructions in the owner's manual and local codes. This warranty applies to the original purchaser/owner of the Fire Chief Furnace and is not transferable. Replacement or repair parts are warranted for the remaining period of the original warranty.

All warranty claims must include:

- Date of purchase
- Model and serial number
- Proof of purchase (dated invoice, bill of sale, cancelled check, or payment record)
- The name / address of the store from which you purchased the furnace

Fire Chief Industries warrants the firebox and cast iron grates to be free of defects in material and workmanship for 5 years from the date of the original purchase. The cast iron grates are warranted for 5 years so long as the furnace is operated safely in accordance with the owner's manual. The firebox and cast iron grates will be prorated after 1 year at a 20% rate each year thereafter. **Intentional misuse or abuse causing burn through of cast iron components is NOT warranted.** Over firing the furnace will cause the front face to crack and is not covered by the warranty. Furthermore, some cosmetic deterioration can be expected as the result of normal operation, therefore the physical appearance is not guaranteed to remain unchanged. The manufacturer warrants all electrical components for 1 year and the blower motor for 2 years. Please be advised that the firebrick and door gaskets are excluded from this warranty.

In order to exercise the aforementioned warranty, a certified professional must determine the appliance/part to be defective. He or she must submit a written statement to Fire Chief Industries detailing an assessment of the problem. This assessment **MUST** be accompanied by substantiating proof of purchase (dated invoice, bill of sale, cancelled check, or payment record), model and serial number. Fire Chief Industries will then authorize repair or replacement as appropriate to the submitted claim. Fire Chief Industries will not honor expenses incurred from any action that was not expressly consented to in writing. The owner is hereby notified that he or she will be obligated to assume liability for removal, re-installation, shipping, and labor costs involved in servicing/repairing or replacing the part or unit. The merchandise in question must be shipped via **PREPAID FREIGHT** to Fire Chief Industries. Fire Chief Industries will return the repaired or replacement part to the purchaser on a **FREIGHT COLLECT** basis.

This warranty will be rendered null and void if this part/unit exhibits symptoms of obvious over-firing, deliberate abuse or negligence, improper installation, or is used for commercial purposes.

Finally, Fire Chief Industries will not be responsible for any claim not stated in our warranty nor does any implied warranty extend beyond the limits stated above.

Please contact Fire Chief Industries with all pertinent information including daytime phone number and detailed description of the type of problem you are having. Fire Chief Industries technical service personnel will contact you as soon as possible. Call 1-800-875-4788 or mail information to: Fire Chief Industries, 10950 Linpage Place, Saint Louis, MO 63132.

