

FIRE CHIEF



A **HYC** COMPANY

WOOD BURNING INDOOR FURNACE MODEL: FC1000E

U.S. ENVIRONMENTAL PROTECTION AGENCY
Certified to comply with 2020 particulate emission standards.



Manufactured By:

Fire Chief Industries

10950 Linpage Place St. Louis, MO 63132

1-800-875-4788 | www.hy-c.com



November 2019

MADE IN THE USA



Intertek

Certified to
UL391 (Sept. 2010)
CSA B366.1 (2014)

THIS IS NOT A WOOD STOVE!

This is an **EPA**
Certified Wood Burning
Warm Air Furnace.

DO!

- Use dry, properly seasoned wood.
- Install a properly sized stainless steel liner in existing, open chimneys for maximum performance.
- Confirm that all firebricks are properly installed prior to and during operation. Always replace with factory components.
- Avoid the use of 90° elbows in the chimney system or any required air duct venting.
- Properly design the cold return air and the warm supply air. They may never be restricted.
- Locate the return air as a direct connection to the heated area of the home where the thermostat is located.

DO NOT!

- Modify or adjust any furnace component! Doing so will VOID your Manufacturer's Warranty and can cause significant damage to your wood burning warm air furnace.
- Use a damper in the flue!
- Install the air filter box intake closer than 12" to the wall!
- Operate with the fuel or ash pan door open!
- Operate the furnace in a negative pressure environment!
- Operate if any components (firebricks, doors, distribution blower, draft blower) are not functioning or installed properly!
- Replace any components (firebricks, doors, blowers) with non-factory components!

QUESTIONS?

HYC

Please call Customer Service before proceeding:

800-875-4788

10950 Linpage Place St. Louis, MO 63132 www.hy-c.com

TABLE OF CONTENTS

| | |
|---|----|
| Proper Burn Practices _____ | 2 |
| Model FC1000E _____ | 3 |
| General Information _____ | 4 |
| Location and Installation _____ | 5 |
| Assembly of Unit | |
| Blower and Housing _____ | 6 |
| Filter Box _____ | 7 |
| Chimney Types and Recommendations _____ | 8 |
| Installation of Ducting _____ | 10 |
| General Operation | |
| Types of Wood to Use _____ | 11 |
| First Fire _____ | 13 |
| Loading Wood _____ | 13 |
| Disposal of Ashes _____ | 13 |
| Draft Blower _____ | 14 |
| Creosote Formation _____ | 14 |
| Creosote Prevention _____ | 14 |
| Chimney Fire Warning _____ | 14 |
| Power Failure _____ | 14 |
| Furnace Diagram with Parts List _____ | 16 |
| Blower Motor Assembly Diagram _____ | 17 |
| Wiring Diagram _____ | 18 |
| Troubleshooting _____ | 19 |
| Warranty Information _____ | 25 |

DOUBLE CHECK TO MAKE SURE YOU HAVE RECEIVED ALL OF THE REQUIRED COMPONENTS. IF YOU FIND THAT THERE IS A PART MISSING, CALL 1-800-875-4788 IMMEDIATELY. PLEASE DO NOT RETURN THE UNIT TO THE STORE OR TO THE DEALER.

PROPER BURN PRACTICES **FOR MAXIMUM EFFICIENCY AND SAFETY!**

- The chimney is one of the most important elements of the furnace. If the chimney is not connected properly and installed according to manufacturer's specification and national and local codes, the unit is not safe and will not burn efficiently. Lack of proper chimney installation will cause unit to produce more smoke and less heat output. See Pages 5-10 of this manual to ensure proper installation.
- Proper use of all electrical components is essential. The wall thermostat must be hooked up to the furnace and located within the heated area of the home.
- To maximize the performance of the furnace, the draft blower may not be adjusted or altered in any manner.
- Wood that is properly cut and stored to dry will produce more BTUs and higher heat output than wood that has a higher moisture content. Wood with higher moisture content will create creosote in the chimney and cause flue fires.
- There should be no alteration of the Fire Chief furnace in any way, as this will void the UL391 safety listing and affect the operation of the furnace. This will also void the warranty of the unit.
- Fire Chief makes two types of units, indoor as well as outdoor furnaces. The indoor units are manufactured and tested for indoor applications only. They are not meant to go outside the house but must be placed indoors in a basement or utility room. Any indoor unit placed outside the home in a shed or building will void the warranty, violate the safety listing, and will not produce the maximum efficiency possible with this unit. For outdoor applications please use model FC1900.
- Indoor units may not be installed in mobile homes.



FIRE CHIEF INDOOR FURNACE MANUAL

MODEL: FC1000E

U.S. ENVIRONMENTAL PROTECTION AGENCY Certified to comply with 2020 particulate emission standards.

SAVE THESE INSTRUCTIONS

Congratulations! You have selected the finest quality wood burning indoor furnace, manufactured with pride in the USA. Please take a few moments to carefully read the owner's manual. By taking the time to familiarize yourself with your new Fire Chief Furnace, you will be able to look forward to years of trouble-free, dependable service.

Installation:

First: Check local codes. The installation must comply with all local rules and requirements.

Furnace installation is to be performed by a qualified installer. This furnace must not be installed in trailers or mobile homes. Always have a properly installed and functioning smoke detector in your home. To prevent accidental injury, do not allow anyone who is unfamiliar with the furnace to operate it. ***Spend time familiarizing yourself with your Fire Chief Furnace.*** It is impossible to predict how the furnace will perform due to variations in installation, fuel, and environmental factors. Understanding that furnace performance can be impacted based upon wood species, wood quality, wood length, and wood reloading levels will improve your overall experience.

Transportation Damage:

Every effort has been made to ensure that your Fire Chief Furnace will arrive in perfect condition. Any visible damage should be noted on the freight bill at the time of delivery. If upon unpacking your Fire Chief Furnace you find that damage has occurred during transit, notify your dealer immediately. Your dealer will advise you what actions must be taken to address the problem.

Disclaimer Notice:

The listed BTU rating for your new Fire Chief Furnace was obtained using laboratory calculations. ***The actual BTU output you experience may vary somewhat depending on the type, condition, and moisture content of the fuel used, chimney type, and other factors.*** Therefore, the manufacturer disclaims any guarantee as to the BTU output or capacity. Fire Chief disclaims any responsibility for the following: installation of a furnace that has been altered or modified in any way; installation of the furnace other than as instructed in this manual; installation and/or use of any component or part not approved by Fire Chief for use with this furnace. ***Be sure to complete your warranty registration within 30 days of purchase in order to activate warranty coverage on your furnace. Register online: www.hy-c.com/warranty-serial.***

Manufacturer's Notice:

Please be advised that we periodically make changes to improve our products, therefore the information in this manual may not be completely applicable to your Fire Chief Furnace. Please refer to markings on the appliance for additional information.

This wood heater has a manufacturer-set minimum low burn rate that must not be altered. It is against federal regulations to alter this setting or otherwise operate this wood heater in a manner inconsistent with operating instructions in this manual.

THIS IS A WOOD BURNING FURNACE ONLY AND SHOULD NOT BE ALTERED IN ANY WAY.

General Information

The Fire Chief 2020 EPA-Certified Furnace has been engineered to accommodate the heating requirements of the average sized home, even during winter's coldest months. It is constructed with high grade, heavy gauge steel and is continuously welded to assure the highest structural strength. In addition, the firebox is lined with insulated stainless steel panels to ensure many years of energy efficient service. The design of the secondary combustion chamber increases fuel efficiency by creating a "secondary burn" of smoke and wood gases before they are vented up the chimney. The cast iron doors are custom fitted to provide an airtight seal, greatly extending the burn time and ensuring maximum efficiency in fuel consumption. The heavy-gage cast iron grate allows for convenient ash removal and reduced maintenance.

For total comfort and convenience, a thermostatically-controlled Draft Blower and fan-limit-controlled Circulation Blower are included. These fully automatic components provide heat disbursement throughout your home, minimizing recovery time when the wall thermostat demands heat.

All of these features are standard, offering you the most efficient, durable, and affordable indoor wood burning furnace.

Efficiency was determined using the higher heating value of the fuel per B415.1-10 testing requirements. Dry seasoned wood will develop greater BTU output. A well-insulated dwelling will always lead to better results and overall improved fuel usage efficiency.

Your Fire Chief Furnace is designed to be either a supplemental or central heating source for your home. This wood burning furnace may be installed in parallel with a properly operating electric, gas or oil-fired central furnace, listed or certified in accordance with a nationally recognized safety standard, and within clearances specified on the nameplate. When in a parallel installation, the static pressure of the central furnace plenum may not exceed 0.15 water column inches, and the maximum setting on the central furnace limit switch is 182°F. With the Fire Chief Furnace in an "Interconnection Arrangement," your furnace should be upstream of the central furnace. The Fire Chief Furnace warm air supply should never be connected to return air for the central furnace. A qualified installer should perform the installation.

IMPORTANT: FOR TECHNICAL SUPPORT OR CUSTOMER SERVICE ISSUES, DO NOT RETURN TO THE STORE OR TO THE DEALER. CALL 1-800-875-4788.

Forced Hot Air Circulation:

The plenum size of your Fire Chief Furnace must not be reduced to less than 100 square inches, and must provide a minimum of 18 inches between the top of your Fire Chief Furnace and the main trunk connection. Do not modify the outer shell of the furnace at any time. The plenum attached to the furnace must be constructed of metal. The warm air supply duct system should be constructed of materials with a minimum temperature rating of 250°F.

Clearances:

Unit must be placed on a non-combustible floor. This floor must extend at least 16 inches in front of, and 8 inches on either side of, the fuel loading and ash removal doors; underneath the chimney connector; and 2 inches on either side of the chimney connector. The furnace must maintain the following clearances to combustibles:

- Heat plenum = 2 inches
- Chimney connector = 18 inches
- Front = 48 inches
- Rear = 12 inches
- Sides = 6 inches
- Main furnace = 12 inches

These are minimum clearances and should be strictly followed. In the case of a power outage, a dangerous level of heat accumulation may develop. Do not store fuel or other combustible materials within installation clearances.

Location and Installation

NOTE: Before beginning installation, consult proper local authorities regarding local codes governing all such applications and installations.

DO NOT CONNECT THIS UNIT TO A CHIMNEY FLUE SERVING ANOTHER APPLIANCE. Your furnace must be placed on a non-combustible floor. Position the furnace as close to the chimney as possible. Air for combustion must be provided into the room where the furnace is located. Allow air free access to the furnace for combustion and ventilation.

In negative pressure situations, Fire Chief recommends the installation of a Fresh Air Kit (WAF-FAK10).

The installation of a warm air furnace within an attached garage is prohibited by building codes and regulations.

RECOMMENDATION: Smoke detectors and carbon monoxide detectors should be installed on all levels of your home. Having a fire extinguisher within close proximity is strongly recommended.

This wood heater needs periodic inspection and repair for proper operation. It is against federal regulations to operate this wood heater in a manner inconsistent with operating instructions in this manual.

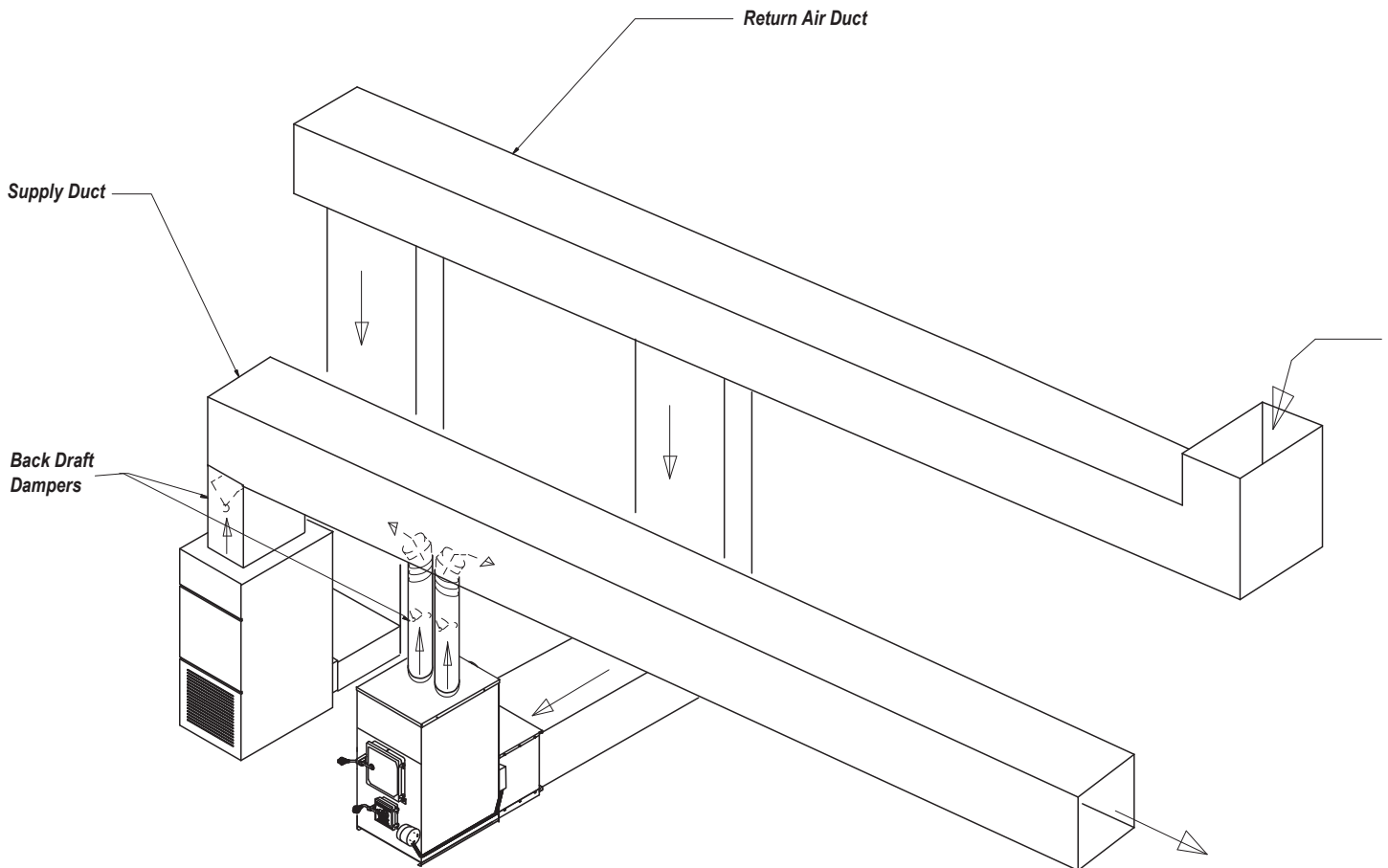

Assembly of Unit

Please review the parts list and diagrams contained on pages 16-17 of this manual.

DOUBLE CHECK TO MAKE SURE YOU HAVE RECEIVED ALL OF THE REQUIRED COMPONENTS. IF YOU FIND THAT THERE IS A PART MISSING, CALL 1-800-875-4788 IMMEDIATELY. PLEASE DO NOT RETURN THE UNIT TO THE STORE OR TO THE DEALER.

NOTE: For your convenience your Fire Chief Furnace has been factory assembled and the electrical control assembly pre-wired.

1. Fasten the right and left side angle brackets to the circulation blower using (4) 1/4 - 20 bolts and nuts.

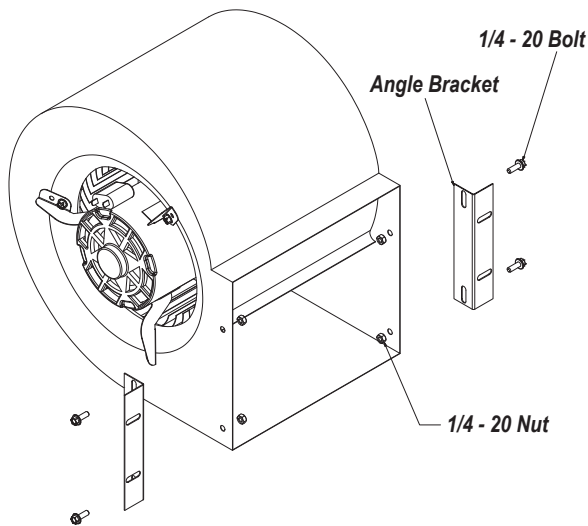

2. Line up the blower with the pre-drilled holes on the backside of the furnace and firmly attach with the screws provided.

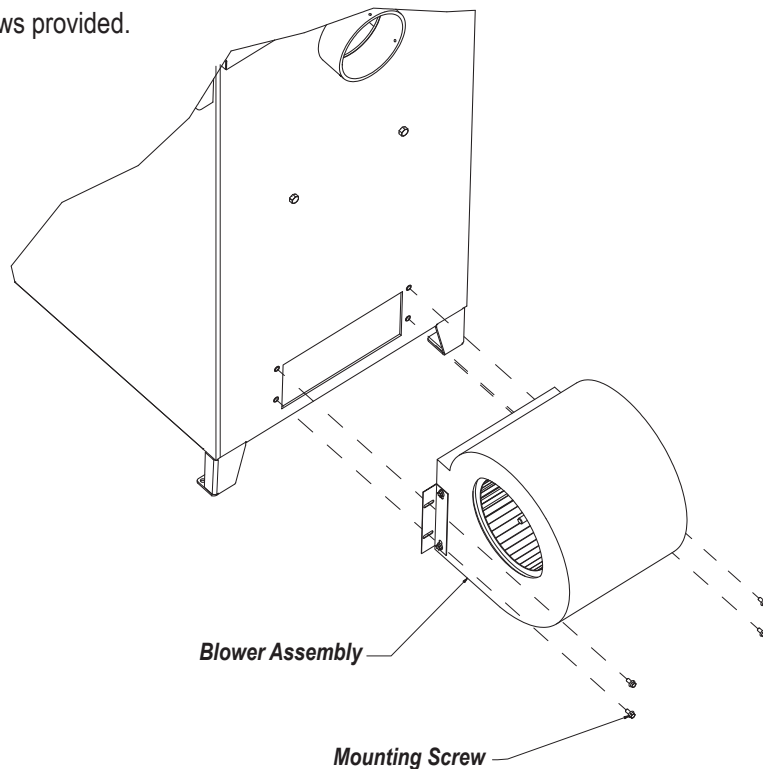

3. Assemble the following parts using 6 #8 sheet metal screws. Both "B" and "C" panels should fit inside the bottom "A" panel flanges. Attach "B" and "C" (side panels) to "A" (bottom panel). After the bottom and sides are assembled, attach "A" (top panel) using 6 #8 sheet metal screws provided.

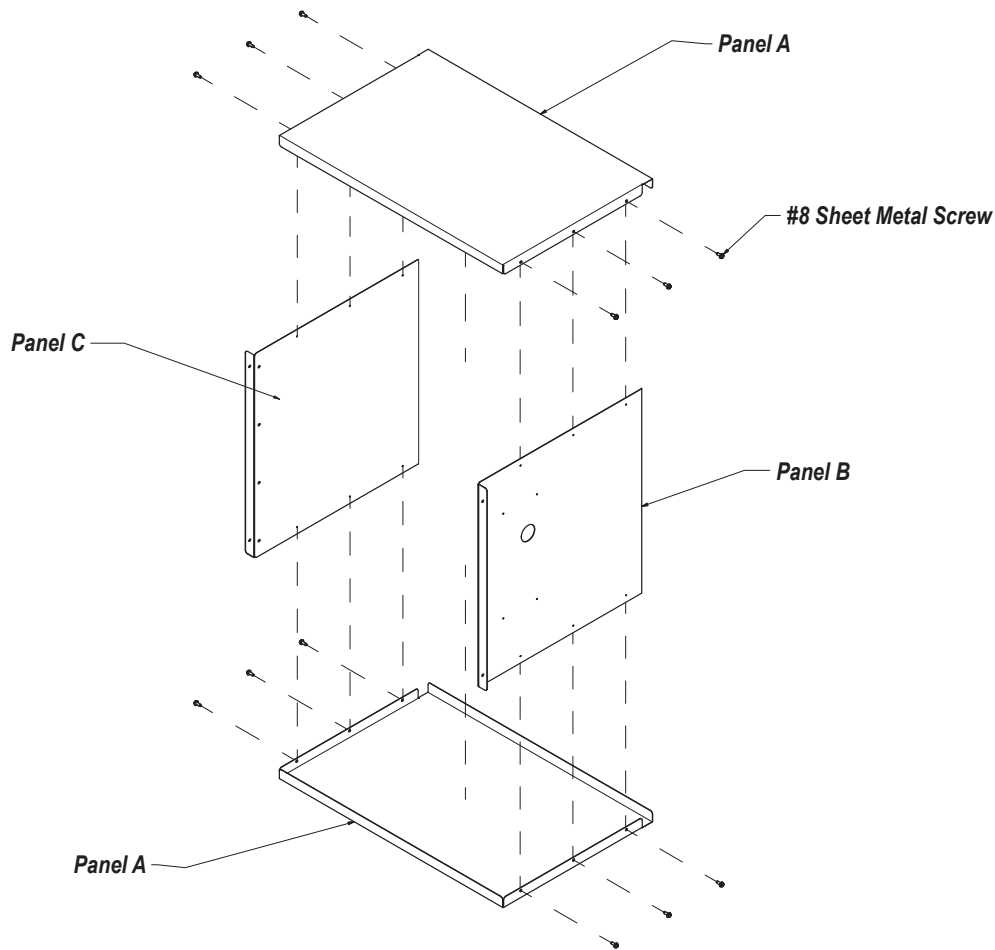

4. Position the assembled filter box on rear of furnace, supporting it firmly up to electrical enclosure, covering the rear distribution blower. Make sure the filter box is tightly pressed to the back of the furnace. Use 4 1/4" bolts (included) to firmly attach the filter box to sides of furnace.

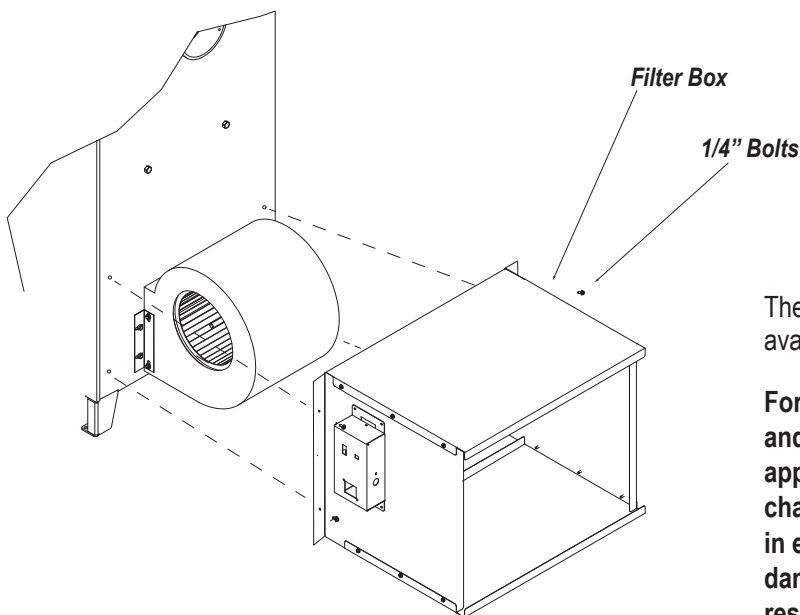

The filter box requires one 20" x 20" x 1" filter (not included, but available at most hardware and home centers).

For maximum furnace efficiency, inspect your filter regularly and replace the filter when airflow is restricted and the filter appears dirty. Some environments may require more frequent changing of the filter. Failure to replace the filter will result in excessive temperatures causing poor performance and damage to the furnace. It is strongly recommended to use less restrictive, low cost filters.

5. Mount the forced draft blower to the front of the unit with three 1/4-20 x 3/4" bolts (provided).

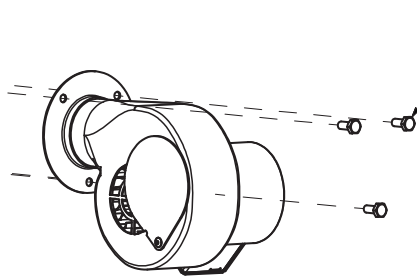

Attach with three (3) 1/4-20 x 3/4" bolts (provided)

6. To install the fan limit control, remove cover, attach with three (3) #8 screws in pre-drilled holes and replace cover.

7. Mount the electrical control center with four (4) #8 screws (provided).

8. Secure the flex conduit to the side of the furnace using the brackets with #8 screws (provided).

9. Plug distribution blower into the back of the electrical control center.

10. Connect the 28-gauge thermostat wire (not included) to the two (2) posts located on the side of the control center. For convenience, you might consider locating the wall thermostat next to your existing thermostat in your home. The thermostat **MUST** be installed for the furnace to operate.

11. Plug the 3-pronged grounded plug into a grounded electrical outlet.

12. With the connection of your chimney pipe and ductwork, your installation is complete.

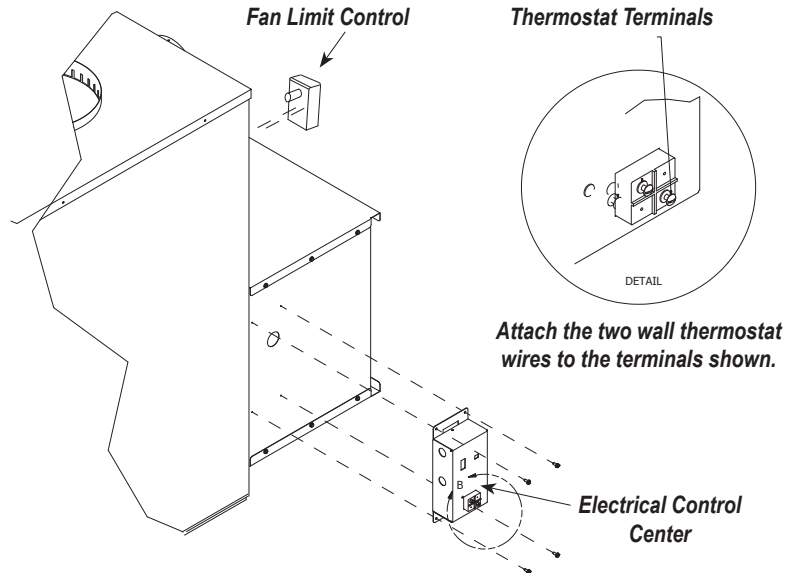

Chimney Types and Recommendations

See Diagram on page 9.

The chimney system is a critical element in the overall performance of the furnace. An improperly sized chimney, poor drafting chimney, unlined chimney, or chimney failure may result in unacceptable performance of the system, product failure, and/or fire and significant loss. Fire Chief strongly recommends the chimney system be professionally cleaned and inspected prior to installation. Check with local regulations to confirm whether or not inspection is required prior to installation.

This furnace should only be connected to a clay-lined masonry chimney, masonry chimney with a properly installed SS 6" liner, or metal all-fuel Class A HT2100 chimney system. Refer to the installation instructions from the chimney manufacturer for proper installation methods and required clearances. Regardless of your chimney type, a minimum 6" diameter flue is required and at no time may the chimney be greater than 12" in diameter or exceed a .08 WCI of draft. The flue draft should be confirmed using a draft gauge or manometer. **NEVER CONNECT THE FURNACE TO AN UNLINED CHIMNEY.** We strongly recommend the installation of a 6" stainless steel liner for all systems to maintain a higher flue temperature which minimizes the accumulation of creosote and improves overall performance.

The connection of the furnace to the existing chimney may be completed using a minimum of 24-gauge single wall black stove pipe or stainless-steel pipe. **NEVER USE GALVANIZED PIPE WHICH WILL GENERATE DEADLY, POISONOUS GASES.** The connection of the furnace to the chimney may never exceed a 60" (5') horizontal run and must maintain a minimum rise of 2 inches per foot. Never install more than two (2) elbows when connecting to the existing chimney and the use of 45-degree elbows over one 90-degree elbow is recommended. For easy cleaning of the chimney system, install a clean-out "T" on the rear of the furnace and never operate the furnace without a cap installed on the clean-out access.

All piping sections should be fastened together with the proper locking bands or a minimum of three (3) screws per section. The crimped or male end of all chimney sections should install pointing downward, towards the furnace, to form drip-free connections.

CHIMNEY HEIGHT REQUIREMENTS

The chimney must extend at least three feet above the highest point where it passes through the roof surface and at least two feet higher than any part of the building within a horizontal distance of ten feet.

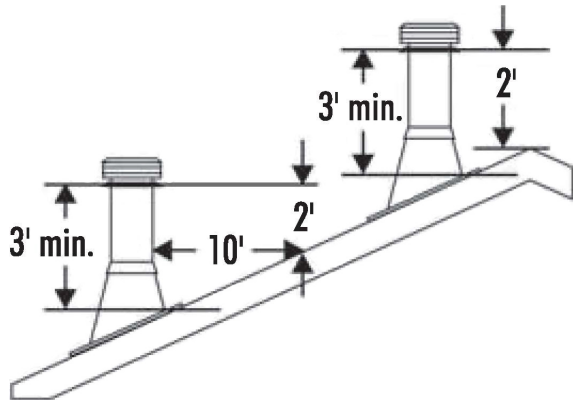

The termination cap should be designed to inhibit down-drafting without restricting the exhaust discharge.

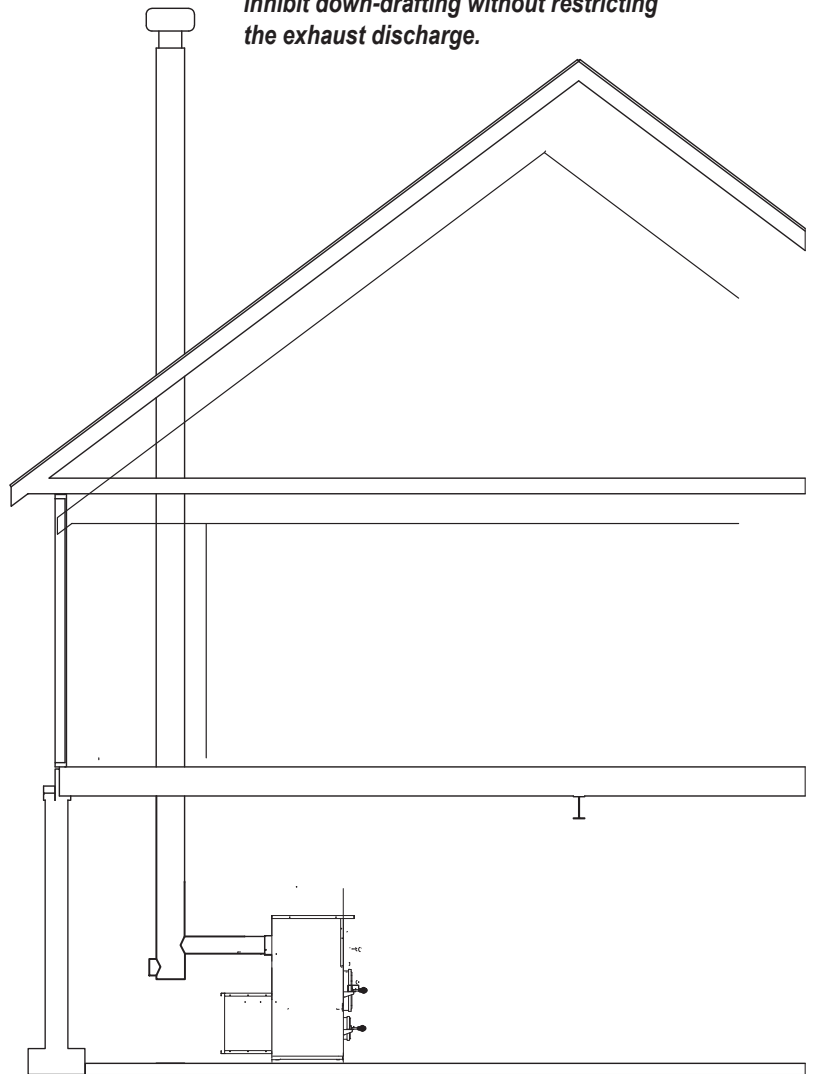

- When installing into an unlined brick chimney, lining the entire chimney with stainless steel chimney liner is strongly recommended. The liner must be 6" for the FC1000E.
- The diameter of the chimney stack should be consistent throughout the length of the chimney.
- The chimney size should be at least as large as the exhaust stack on the furnace, but not more than twice its size.
- The chimney stack should have a built-in airtight clean-out.
- Do not operate the furnace with the clean-out uncapped.

WARNING - RISK OF FIRE:

- Do not operate with flue draft exceeding .08 water column inches (19.9 Pa).
- Do not operate with fuel loading or ash removal doors open.
- Do not store fuel or other combustible materials within marked installation clearances.
- Inspect and clean flues and chimney regularly.

DANGER - Risk of Fire and Explosion:

- Do not burn garbage, gasoline, naphtha, engine oil, or other flammable liquids/inappropriate materials.

WARNING:

- **NEVER** use galvanized pipe in your chimney connection, it produces poisonous gases when subjected to extreme temperatures.
- **USE** only lined masonry or manufactured Class "A" HT2100 All Fuel Chimney for your furnace.
- **INSPECT** chimney system periodically for structural integrity.
- **CLEAN** the chimney system regularly to prevent creosote accumulation.
- **NEVER** leave the ash pan in your furnace during operation.
- **DO NOT CONNECT THIS UNIT TO A CHIMNEY FLUE SERVING ANOTHER APPLIANCE.**

Installation of Ducting

- Proper ducting of the Cold Air Return and Warm Distribution Air is critical to ensure comfort throughout your home.
- Consult a local HVAC contractor for assistance with the design and installation of effective ducting.
- The furnace may be installed as a Dedicated System with separate cold/warm air ducting or an In-line System sharing the ducting of an existing central furnace. Careful consideration is required for both installations.
- All duct connections should be properly supported, fastened, and sealed to maximize air flow.
- The installation of the furnace within the basement may increase the negative pressure in the basement, especially if there are other appliances (i.e. dryers, central vac systems) operating in the basement. In these cases, it may be necessary to provide fresh air to the basement by installing a Fresh Air Kit (WAF-FAK10) to ensure proper performance. Please contact your dealer or call 1-800-875-4788.

Warm Distribution Air Ducting: Ducting off the Top of the Furnace with Two (2) 8" Collars

- All ducting materials must be approved and listed for 250°F.
- All ductwork should be designed to allow a maximum external static pressure of .20 water column inches.
- Do not install a damper which may reduce the airflow of the distribution air.
- Never alter the top of the furnace by enlarging the 8" duct connection collars. If installing a plenum to the top of the furnace, the existing openings must remain.
- Never connect the warm air of the wood furnace with the return air of an In-line furnace. The high heat output of the furnace may overheat the components of the central furnace.

Cold Air Return Ducting: Ducting to Filter Box on Rear of Furnace

- This 2020 EPA-Certified Warm Air Furnace is engineered to perform as a whole home heating solution with the Cold Air Return connected directly to the heated living area. This can be accomplished by connecting directly to the existing return air ducting or by installing a properly sized, unrestricted, independent return air system. Failure to do so will impact the comfort level, performance and efficiency of the overall system.
- The Cold Air Return must be a minimum of 10% larger than the size of the warm air distribution outlets. The minimum size of the return air must be 110 sq. inches. Failure to provide adequate return air will result in poor performance and overheating of the furnace.
- Connections of ductwork to the rear of the filter box should allow a minimum space of 6" clearance from the filter. Be sure to maintain required clearances and at no time should the ducting be closer than 6" to an adjacent foundation wall.
- Minimize the use of elbows to maximize airflow and reduce resistance.
- **IMPORTANT:** When direct connecting the return air to the central furnace return air it is necessary to install a back-draft damper on the warm air side of the central furnace to eliminate pulling the warm distribution air from the wood furnace through the central furnace and back into the Cold Air Return ducting of the wood furnace.
- Passive Cold Air Return ducting is not recommended but may be accomplished by installing open floor grates, louvers in basement doors, and registers in existing return air ducting. It is critical to provide adequate return air as described above.

Canadian Requirements for Supplemental/Add-On Furnaces

- DO NOT USE DUCT ELBOWS HAVING AN INSIDE RADIUS OF LESS THAN 6 INCHES (150mm) ON OIL, ELECTRIC, OR GAS FURNACES.
- DO NOT CONNECT TO A DOWN-FLOW FURNACE.
- DO NOT CONNECT DUCTWORK SO THAT A REVERSE FLOW IS POSSIBLE.
- OPERATE THE GAS/OIL/ELECTRIC/ FURNACE PERIODICALLY TO ENSURE THAT IT WILL OPERATE SATISFACTORILY WHEN NEEDED.
- CERTIFIED FOR INSTALLATION WITH APPROPRIATE DUCTWORK CONFIGURATIONS ONLY.
- DO NOT RELOCATE OR BYPASS ANY OF THE SAFETY CONTROLS IN THE ORIGINAL GAS/OIL/ELECTRIC FURNACE INSTALLATION.
- DO NOT CONNECT TO ANY GAS FURNACE THAT HAS NOT BEEN CERTIFIED INITIALLY AS COMPLYING WITH CAN/CGA-2.3.
- THE OPERATION OF THE GAS FURNACE MUST BE VERIFIED FOR ACCEPTABLE OPERATION BEFORE AND AFTER INSTALLATION OF THE ADD-ON APPLIANCE BY A GAS FITTER WHO IS RECOGNIZED BY THE REGULATORY AUTHORITY.
- DO NOT CONNECT TO ANY GAS FURNACE THAT IS NOT EQUIPPED WITH AN AIR-CIRCULATION BLOWER, OR TO A CHIMNEY OR VENT SERVICING A GAS FURNACE OR GAS APPLIANCE.

The add-on unit should only be installed on a furnace duct system and chimney that are in good operating condition.

If exhaust fans are installed in the storage area they should not create negative pressures in the room where the solid fuel-burning appliance is located.

On a belt-driven system, blower and motor pulleys may be changed but the electrical current flowing through the motor cannot exceed the nameplate rating. On a direct-drive system, the motor should not be changed, however, the speed of the motor may be increased. The blower cannot be changed. This equipment should be installed, acceptable to regulatory authority, by experienced licensed personnel.

Establish a routine for the storage of fuel, care of the appliance, and firing techniques.

Check daily for creosote build-up until experience shows how often cleaning is necessary.

Be aware that the hotter the fire, the less creosote is deposited, and that weekly cleaning may be necessary in mild weather, even though monthly cleaning may be enough in the coldest months. A small intense fire is preferable to a large smoldering fire to reduce the amount of creosote deposition.

The installation should comply with requirements of CAN/CSA-B365, and changes to the installation should comply with CSA-B139 (for oil-fired), C22.1 (for electric), or CAN/CGA-B149.1 or CAN/CGA-B149.2 (for gas-fired).

BURN WOOD ONLY!

General Operation

Types of Wood to Use:

We advise using only dry, seasoned hardwoods in your Fire Chief Furnace rather than high resin woods such as pine. Firewood should be cut at least one full season prior to the time of its intended use for optimum heat output. Firewood should be stacked to provide a free flow of air between the logs, thus allowing more rapid seasoning of the wood. Proper seasoning of wood requires exposure to sun and wind, and shelter from all precipitation. For strategies to best achieve this, please visit www.link.hy-c.com/EPABurnWise1 and www.link.hy-c.com/EPABurnWise2.

FUEL RECOMMENDATIONS: FC1000E – 20-inch maximum log length

Follow instructions included with the moisture meter that was supplied with this unit to make sure that you are using seasoned wood to achieve the cleanest burn and highest efficiency possible. When using the moisture meter, in addition to following the manufacturer's instructions, look for readings under 25% moisture content. Seasoned wood will be a noticeably lighter weight than green wood, and generally has ends with visible cracks. **For strategies to best store and season your wood, please visit www.link.hy-c.com/EPABurnWise1 and www.link.hy-c.com/EPABurnWise2.**

Use extreme caution when opening the door during operation; temperatures are extreme. Wait at least 10 seconds after releasing the latch, and then proceed to the fully open position. Opening the door in this manner is designed to eliminate the possibility of gaseous ignition. Heat resistant gloves are recommended when opening the fuel door or emptying the ash pan.

CAUTION: HOT SURFACES. KEEP CHILDREN AWAY. DO NOT TOUCH DURING OPERATION.

This wood heater needs periodic inspection and repair for proper operation. If you observe excessive smoke, check to be sure you are burning properly seasoned cordwood and that there are no gaps in the gaskets on the door of the unit. When it becomes necessary to replace the gaskets:

- Order part number FCGSKT58 (fuel door) and/or FCGSKT12 (ash door)
- Remove old gasket
- Install new gasket in gasket channel of door
- Cut off excess gasket, ensure that there is no gap where the ends of the gasket material meet

CAUTION:

- **INSPECT FLUE PIPES, JOINTS, AND SEALS REGULARLY TO ENSURE THAT SMOKE AND FLUE GASES ARE NOT DRAWING INTO, AND ARE NOT BEING CIRCULATED BY THE AIR-CIRCULATION SYSTEM.**
- **CLEANING OF THE HEAT EXCHANGER, FLUE PIPE, CHIMNEY, AND DRAFT INDUCER (IF USED), IS ESPECIALLY IMPORTANT AT THE END OF THE HEATING SEASON TO MINIMIZE CORROSION DURING THE SUMMER MONTHS CAUSED BY THE ACCUMULATED ASH.**
- Never use chemicals or gasoline to start or maintain your fire.
- **DO NOT** burn oil, garbage, trash, plastic, or any fuel other than wood in your furnace. Doing so will void the warranty.
- **DO NOT** leave the ash pan inside your furnace during operation.

WARNING: RISK OF FIRE

- **DO NOT** operate with flue draft exceeding .08 water column inches (19.9 Pa).
- **DO NOT** store fuel or other combustible materials within marked installation clearances.
- Inspect and clean flues and chimney regularly.
- **DO NOT** operate your furnace with the fuel or ash doors open.

WARNING:

NEVER fuel your furnace with wet, unseasoned wood or wood that has been exposed to a recent rainfall. Burning wood with high moisture content will cause a rapid accumulation of hazardous creosote, which has been proven to be the most common cause of flue fires. NEVER burn plastics, any wood product containing glue, or wood treated with chemical preservatives in your furnace. The combustion of these substances may release harmful, toxic gases.

Do Not Burn:

- Garbage;
- Lawn clippings or yard waste;
- Materials containing rubber, including tires;
- Materials containing plastic;
- Waste petroleum products, paints or paint thinners, or asphalt products;
- Materials containing asbestos;
- Construction or demolition debris;
- Railroad ties or pressure-treated wood;
- Manure or animal remains;
- Salt water driftwood or other previously salt water saturated materials;
- Unseasoned wood; or
- Paper products, cardboard, plywood, or particleboard. The prohibition against burning these materials does not prohibit the use of fire starters made from paper, cardboard, saw dust, wax, or similar substances for the purpose of starting a fire in a wood heater.

DANGER: RISK OF FIRE OR EXPLOSION: Do not burn garbage, gasoline, naphtha, engine oil, or other flammable liquids/inappropriate materials.

Supplemental Outside Combustion air may be necessary if:

- The solid-fuel-fired appliance does not draw steadily, smells, experiences smoke roll-out, burns poorly, or back-drafts whether or not there is combustion present. Opening a window slightly on a calm day may alleviate these symptoms.
- The house is equipped with a well-sealed vapor barrier and tight fitting windows, and/or has any powered devices which exhaust house air.
- There is excessive condensation on windows in the winter.
- A ventilation system is installed in the house.

BURN WOOD ONLY!

NEVER operate the furnace with the fuel door or ash door open! NEVER operate the furnace with the ash pan left inside of the unit!

First Fire:

Set the wall thermostat to 90°F.

Place several crumpled newspapers on the grate with some dry kindling layered on top of the papers, then ignite the newspaper and close the fuel door. After approximately 5 minutes, open the fuel door, add several small pieces of wood and then close the door. After about 20 minutes the fire should be established, allowing you to load the firebox and set the wall thermostat to the desired home temperature.

Do not over-fire the furnace. Over-firing by overloading/over-fueling the furnace causes the metal to superheat and expand, then cool rapidly, which causes cracking, therefore voiding the warranty. Over-firing, or abuse, can easily be determined upon inspection.

The ash pan must remain out of furnace during operation.

NOTE: Your new Fire Chief Furnace is capable of producing a very high BTU output. Do not fuel your furnace to capacity upon initial firing. It's recommended that you become thoroughly familiar with your Fire Chief Furnace before operating at full capacity.

The new steel and metal components of the furnace have a protective coating of paint on the surface which could produce an odor during the break in period. Adequate ventilation within the home and furnace room or area is recommended during the initial firing and break in period to accommodate this possibility. Your new Fire Chief Furnace is classified as having airtight construction. This type of design should enable you to experience up to 12 hours of burn time per full load of fuel (***dry, seasoned hardwood***). However, abnormally cold weather may reduce the burn time somewhat, but if your burn cycle is significantly less (for instance 2 to 4 hours), this type of occurrence is usually symptomatic of heat demands in excess of furnace capacity. Contact an authorized professional to determine if your Fire Chief Furnace has been improperly sized for your home. The heat output range, according to B415.1-10 testing, is 17,500 to 50,400 BTUs per hour.

Loading Wood:

When opening the fuel door during operation, always wait 10 seconds after releasing the first latch, then open the door the rest of the way. The dual latch system has been incorporated as a safety feature, designed to eliminate the possibility of gaseous ignition. Laboratory testing has determined that when incomplete combustion occurs the partially spent fuel sometimes concentrates large amounts of potentially hazardous gases within the fire chamber. If the door is opened suddenly under these conditions, the oxygen may combine with these gases and cause ignition referred to as "back flash." Use EXTREME CAUTION when opening the fuel door.

When reloading the furnace, spread embers evenly over the grate. Place smaller pieces of wood on the hot embers and layer larger pieces on top of them. **Finally, due to the wide variety of temperature ranges during the winter, you may experience periods when it is not necessary to fully load the fire chamber in order to maintain an overnight burn.** Your Fire Chief Furnace will operate at the highest efficiency by adding fuel in amounts needed to maintain comfortable temperatures in your home.

BURN WOOD ONLY!

Disposal of Ashes:

Heat resistant gloves are recommended. In order to remove ashes from your Fire Chief Furnace, open the ash door and slide the ash pan to the rear of the furnace. Remove the ash pan from the furnace and dump the ashes into a metal container with a tight fitting lid. The closed container of ashes should be placed on a non-combustible floor or on the ground, well away from all combustible materials, pending final disposal. If the ashes are disposed of by burial in soil or otherwise locally dispersed, they should be retained in the closed metal container until all cinders have thoroughly cooled.

The ash pan must be removed from your Fire Chief Furnace during operation. This precautionary measure is recommended

because if the ash pan is allowed to remain inside the furnace during operation, it will become dangerously hot to touch, block the flow of air under the grates and reduce the efficiency of the furnace.

Remove the ashes from your Fire Chief Furnace at least once a day, or as often as necessary to ensure the ashes do not accumulate to the height of the grates. If ash build-up occurs at grate level, it will cause premature failure of the grate system, voiding the warranty on the grates. Unacceptably high temperatures will result because the ashes have restricted the flow of cooling air beneath the grates. This flow of air was designed to not only cool the grates, but to also provide warmed air for better combustion. If the ash level is improperly maintained the firebox will be starved of combustion air, greatly reducing the efficiency and heat output of your Fire Chief Furnace.

CAUTION: HOT SURFACES. KEEP CHILDREN AWAY. DO NOT TOUCH DURING OPERATION.

IMPORTANT: FOR TECHNICAL SUPPORT OR CUSTOMER SERVICE ISSUES, DO NOT RETURN TO THE STORE OR TO THE DEALER. CALL 1-800-875-4788.

Draft Blower:

The draft blower plays an important role in the operation of your Fire Chief Furnace. When the wall thermostat calls for heat, the draft motor turns on and supplies fresh air into the firebox producing a hotter fire, which in turns provides more heat in the heat chamber. The heat is then sent through the duct system throughout your home. When the wall thermostat temperature is met, the draft blower shuts off until the thermostat calls for heat, beginning the cycle again. Do not alter or adjust the draft blower in any manner.

Creosote Formation and Need for Removal:

When wood is burned slowly, it produces compounds in exhaust smoke which combine with expelled moisture to form creosote. The creosote vapors condense in the relatively cooled chimney flue of a slow burning fire. As a result, creosote residue accumulates on the flue lining. When ignited, this creosote makes an extremely dangerous fire in the chimney. The chimney connector and the chimney should be inspected at least twice monthly during the heating season to determine if a creosote build-up has occurred. If creosote has accumulated it should be removed to reduce risk of a chimney fire.

Creosote Prevention:

To help reduce the formation of creosote within the flue, ALWAYS BURN DRY, SEASONED WOOD. Dry wood burns hotter, allowing flue gases to maintain temperatures above 212°F which should reduce the quantity of creosote in the chimney. If the flue gas temperature falls below 212°F, condensation occurs causing creosote formation and accumulation within the chimney.

As an added precaution, periodic chimney inspections are recommended during the heating season to determine if creosote formation has occurred. For safety and efficiency, it is recommended that the chimney system be inspected and cleaned prior to each heating season.

Chimney Fire Warning:

In the event of a chimney fire, take the following actions immediately:

- DO NOT unplug the furnace.
- Close the ash door, the fuel door, and slide the cover on the draft motor to Power Fail setting.
- Alert entire household and prepare to evacuate if necessary.
- Call your local fire department.

Power Failure:

In case of power failure, to prevent your Fire Chief Furnace from over-heating and causing damage to the electrical components, do NOT add more fuel to the firebox. Remove air filter and position cover on draft motor to Power Fail setting (see diagram on pg.15).

There is no warranty on electrical components damaged due to power failure.

NOTE: OVER-HEATING OR DELIBERATE ABUSE CAN EASILY BE DETERMINED UPON INSPECTION AND WILL VOID THE WARRANTY.

Always burn seasoned wood. Dry wood will produce a higher BTU output and a longer burn time. Refer to the nameplate on furnace for additional information. **For strategies to best store and season your wood, please visit www.link.hy-c.com/EPABurnWise1 and www.link.hy-c.com/EPABurnWise2.**

WARNING: RISK OF FIRE

- **DO NOT** operate with the flue draft exceeding .08 water column inches (19.9 Pa).
- **DO NOT** operate with fuel loading or ash removal doors open.
- **DO NOT** not store fuel or other combustible material within marked installation clearances.
- Inspect and clean flues and chimney regularly.

THIS IS A WOOD BURNING FURNACE AND SHOULD NOT BE ALTERED IN ANY WAY.

Draft Blower Modes



Furnace Diagram

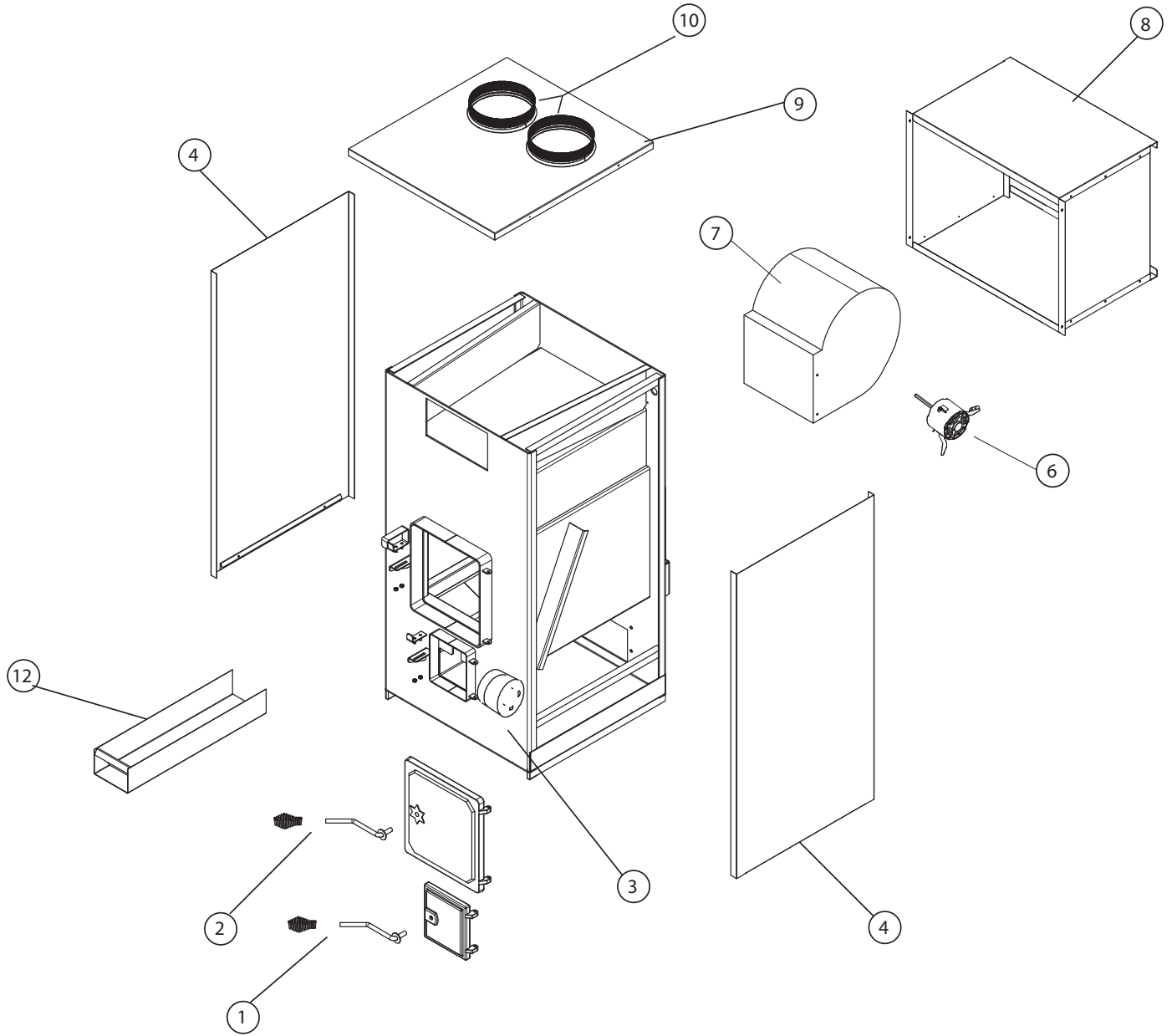

| PARTS LIST | | | |
|------------|-----|---|---------------------|
| ITEM | QTY | PART DESCRIPTION | FC1000E PART NUMBER |
| 1 | 1 | ASH DOOR HANDLE ASSEMBLY | WAF-ADHD |
| 2 | 1 | FUEL DOOR HANDLE ASSEMBLY | WAF-FDHD |
| 3 | 1 | FURNACE SHELL | N/A |
| 4 | 2 | SIDE PANEL ASSEMBLY | FCE-10SPA |
| 5 | 1 | BLOWER ASSEMBLY COMPLETE (NOT PICTURED) | WAF-MK |
| 6 | 1 | BLOWER MOTOR | FC3SPMK |
| 7 | 1 | BLOWER HOUSING ASSEMBLY | FCBH |
| 8 | 1 | FILTER BOX KIT | WAF-10FBK |
| 9 | 1 | TOP PANEL | FCE-10TP |
| 10 | 2 | STARTER COLLAR | SNGCLR08 |
| 11 | 1 | GRATE (NOT PICTURED) | WAF-10CG |
| 12 | 1 | ASH PAN | WAF-10AP |
| 13 | 1 | SECONDARY BAFFLE KIT (NOT PICTURED) | WAF-10SBK |
| 14 | 1 | FIREBOX BRICK KIT (NOT PICTURED) | WAF-10BK |

Blower Motor Assembly Diagram

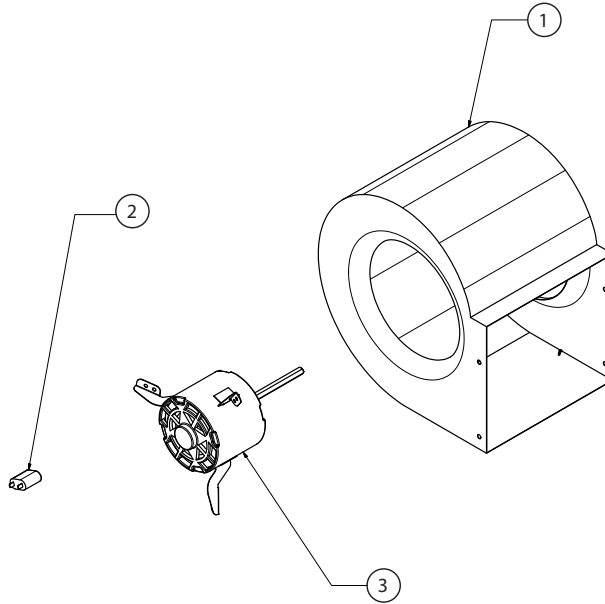

| PARTS LIST | | | |
|------------|-----|-------------------------|-------------|
| ITEM | QTY | PART DESCRIPTION | PART NUMBER |
| 1 | 1 | BLOWER HOUSING ASSEMBLY | FCBH |
| 2 | 1 | MOTOR CAPACITOR | FC3610J370 |
| 3 | 1 | BLOWER MOTOR | FC3SPMK |

Heat Exchange Firebrick Kit

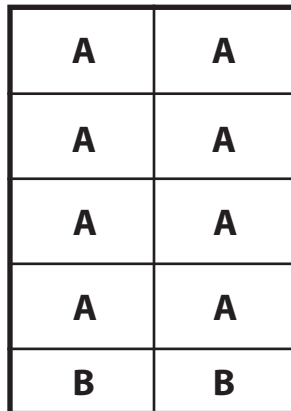

| PARTS LIST | | | |
|------------|-----|---------------------------------|-------------|
| ITEM | QTY | PART DESCRIPTION | PART NUMBER |
| A | 8 | 9" x 4-1/2" x 1-1/4" FIREBRICKS | HTVB |
| B | 2 | 9" x 2-1/4" x 1-1/4" FIREBRICKS | HTVB2 |

Wiring Diagram

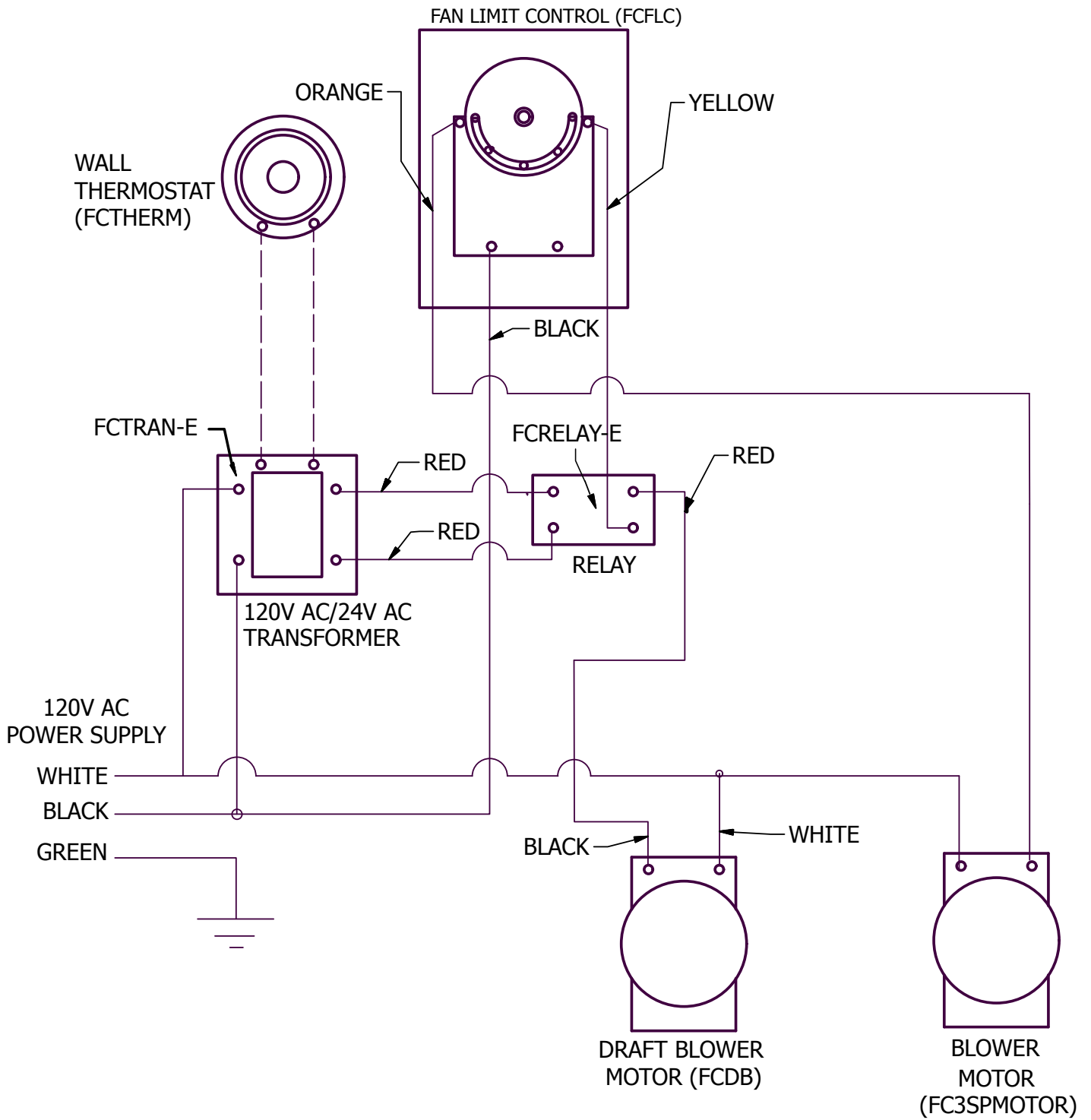

Troubleshooting

1. Problem: Circulation blower runs constantly.

NOTE: Make sure the white button on the fan limit control is pulled out and in the “auto” position.

Possible Causes:

Remedies:

- | | |
|---|--|
| <ul style="list-style-type: none">• Fan limit control is in “TEST” mode: white button is pushed in. | <ul style="list-style-type: none">• Pull white button out into the “AUTO” position. |
| <ul style="list-style-type: none">• “OFF” setting on fan limit control is low. | <ul style="list-style-type: none">• Remove cover on fan limit control and check for the proper setting. The point indicators should be set at 100°F “OFF” and 150°F “ON.” Do NOT attempt to adjust the temperature indicators on the dial. |
| <ul style="list-style-type: none">• Defective fan limit control. | <ul style="list-style-type: none">• Check by moving the “ON” and “OFF” point indicator to a temperature position where blower should turn off. If the blower continues to run, replace the fan limit control. |
| <ul style="list-style-type: none">• Improper wiring. | <ul style="list-style-type: none">• Review wiring diagram. If unit is wired correctly, seek professional assistance. |

2. Problem: Circulation blower vibrates during operation.

Possible Causes:

Remedies:

- | | |
|--|--|
| <ul style="list-style-type: none">• Set screw on squirrel cage is not tight. | <ul style="list-style-type: none">• Check squirrel cage alignment and position so that it does not drag on the housing during rotation, then tighten the screw sufficiently to fasten the squirrel cage securely to the shaft. |
| <ul style="list-style-type: none">• Balance weights on squirrel cage have become dislocated. | <ul style="list-style-type: none">• You may attempt to adjust the weights yourself to obtain an acceptable balance. If you are unsuccessful, contact your supplier. |
| <ul style="list-style-type: none">• Dirt and debris on blower. | <ul style="list-style-type: none">• After the unit is cold, inspect the blower housing and clean as needed. |

3. Problem: Flames discharging from fuel door during reloading.

Possible Causes:

Remedies:

- | | |
|--|---|
| <ul style="list-style-type: none">• Opening the door has provided additional oxygen which has ignited the accumulated gases from partially spent fuel. | <ul style="list-style-type: none">• Always open the door cautiously and allow the safety latch system to perform its designed function, containing gases within the fire chamber. |
| <ul style="list-style-type: none">• Insufficient natural draft or an obstruction in the flue system. | <ul style="list-style-type: none">• See Troubleshooting Problems #6 and #9. |
| <ul style="list-style-type: none">• Fire chamber filled to capacity with unburned fuel. | <ul style="list-style-type: none">• Do not attempt to overload the furnace. |

4. Problem: Draft blower will not run.

NOTE: Verify that the wall thermostat is in the “HEAT” position, and make sure batteries are installed.

Possible Causes:

Remedies:

- | | |
|---|--|
| • Defective wall thermostat. | • This can be checked by turning the thermostat to a temperature setting that is higher than the temperature in your home. If the draft blower does not operate, the thermostat may be defective. Replace it if necessary. |
| • Wall thermostat is in the wrong position. | • Move switch on the wall thermostat to the “HEAT” position. |
| • Defective relay or transformer. | • Replace relay or transformer, as necessary. |
| • Defective draft motor. | • Replace draft motor. |

5. Problem: Excessive dirt accumulation surrounding air registers in the home.

Possible Causes:

Remedies:

- | | |
|---|--|
| • Furnace is not connected to return air duct and is drawing dirt from furnace room floor and discharging it throughout home. | • Connect to return air duct system. |
| • Filter box not installed, or no filter in filter box. | • Install filter box on furnace. Install filter in filter box. |

6. Problem: Smoke from the fire chamber is puffing back through the forced draft motor.

Possible Causes:

Remedies:

- | | |
|--|---|
| • Furnace is not connected to return air and is drawing smoke fumes from the flue. | • Connect return air to duct system, or room may be too airtight. Refer to “Location and Installation” section on page 5. |
| • Excessively long run of stove pipe from furnace to flue. | • Relocate the furnace so the horizontal run does not exceed 5 feet and has a 2 inch rise per foot. |
| • Too many elbows. | • The run should not contain more than 2 elbows. |
| • Poor flue performance. | • See pages 8-9. |
| • Negative pressure in furnace area. | • Provide fresh air to the furnace area by installing a Fresh Air Kit (WAF-FAK10). |

7. Problem: Draft blower runs constantly.

Possible Causes:

- Defective wall thermostat.
- Defective relay or transformer.
- Home is not being supplied with a sufficient amount of heat to satisfy the wall thermostat.
- Improper thermostat wiring.

Remedies:

- This can be checked by turning the thermostat to a lower temperature setting than the temperature in your home. If the draft blower continues to run, the thermostat may be defective. Replace it if necessary.
- Replace relay or transformer, as necessary.
- Have a professional determine the proper size furnace and insulation factor of your home.
- Inspect wires for damage and replace as necessary.

8. Problem: Rapid accumulation of creosote in furnace and flue.

Possible Causes:

- Use of high resin wood, such as pine.
- Insufficient chimney draft.
- Using uninsulated stove pipe for the chimney, especially if the construction is on the exterior of the home.
- Improper connection in stove pipe causing air leakage or a structural defect in the chimney itself.
- Fire box not receiving an adequate amount of oxygen.
- Use of an unlined masonry chimney with a large clay tile opening.

Remedies:

- Completely avoid using if at all possible. If hardwoods are not available, fuel the furnace with smaller loads of wood. This will cause the thermostat to call for more heat more often which will initiate the running of the draft blower. Consequently, fires will be hotter thereby reducing the accumulation of creosote.
- See Troubleshooting Problem #9.
- See pages 8-9.
- Inspect entire flue run, from the exhaust stack of the furnace to the termination cap. Repair as necessary.
- Furnace room may be too airtight to supply a sufficient amount of oxygen for combustion. Install a Fresh Air Kit (WAF-FAK10).
- Install stainless steel liner in masonry chimney to reduce creosote formation and to improve draw. Use appropriate size stainless liner for the furnace.

9. Problem: Down draft on chimney caused by one or more of the following.

Possible Causes:

- Flue has a cold spot which inhibits exhaust discharge from rising properly.
- There is an obstruction outside the chimney, such as a tree.
- Flue is located too close to the peak of the roof or does not rise above it to provide the proper draft.

Remedies:

- This problem may occur in factory built flues because the insulation has settled or a seam has ruptured. In masonry flues, mortar loss may be causing seepage of cooler outside air into the stack. Check entire flue for structural integrity and leakage. Correct or repair as needed, or replace or re-line the chimney.
- Remove obstruction.
- Increase chimney height.

10. Problem: Odor detected in home during initial firing.

Possible Causes:

- There is an oily film that remains on the steel after the manufacturing process. Firing the furnace has raised the temperature of the fire box to a level that is sufficient to vaporize the residue.

Remedies:

- The odor should disappear after a few hours of usage.

11. Problem: Excessive smoke discharge from fuel door during reloading.

Possible Causes:

- Excessively long run of stove pipe from furnace to flue.
- Too many elbows.
- Insufficient draft.
- Excessive smoke accumulation.
- Negative pressure in furnace area.

Remedies:

- See Troubleshooting Problem #6.
- See Troubleshooting Problem #6.
- See Troubleshooting Problem #6.
- See Troubleshooting Problem #9.
- Provide fresh air to the furnace area by installing a Fresh Air Kit (WAF-FAK10).

12. Problem: Home does not achieve comfortable temperature.

Possible Causes:

Remedies:

- Improper ductwork connection to existing furnace.

- Refer to information in the manual relating to the proper installation procedures or contact your local heating and cooling contractor.

- Improperly sized ducting.

- Refer to information in the manual relating to the proper ducting procedures or consult your local heating and cooling contractor.

- Excessive dirt accumulation in air filter.

- Check and replace filter. Proper filter size is 20" x 20" x 1". It is strongly recommended to use less-restrictive, low-cost, filters.

- Combustion chamber not receiving an adequate amount of oxygen.

- Furnace room may be too airtight to supply a sufficient amount of oxygen for combustion. Install a Fresh Air Kit (WAF-FAK10).

- Furnace size is inadequate for your home.

- Consult a professional to determine correct sizing.

- Fueling furnace with wet or unseasoned wood.

- Completely avoid using if at all possible. If circumstances necessitate the use of wet or unseasoned wood, then fuel the furnace with smaller loads. This will cause the thermostat to call for heat more often which will initiate the running of the draft blower.

13. Problem: Distribution blower will not turn on.

Possible Causes:

Remedies:

- Operating temperatures not achieved.

- Continue to burn furnace as recommended. Confirm factory settings on fan limit control.

- Defective capacitor.

- Replace capacitor.

- Defective blower.

- Contact your supplier for a replacement.

- Improper wiring.

- Review wiring diagram. If wired correctly, seek professional assistance.

- Defective fan limit control.

- Check the fan limit control by pushing the white button in to the "TEST" position. If the blower turns on, replace the fan limit control.

FIRE CHIEF



A **HYC** COMPANY

Warranty Information

CERTIFICATE OF LIMITED WARRANTY:

EXTENT OF COVERAGE: This warranty covers any Fire Chief Furnace FC1000E sold in the United States and Canada. This warranty is void if the Fire Chief Furnace is not installed, maintained, and operated in accordance with the instructions in the owner's manual and local codes. Warranty is also null and void if the unit is used to burn materials for which the unit is not certified by the EPA. This warranty applies to the original purchaser/owner of the Fire Chief Furnace and is not transferable. Replacement or repair parts are warranted for the remaining period of the original warranty.

All warranty claims must include:

- Date of purchase
- Model and serial number
- Proof of purchase (dated invoice, bill of sale, canceled check, or payment record)
- The name / address of the store from which you purchased the furnace

Fire Chief Furnace warrants the firebox and cast iron grates to be free of defects in material and workmanship for the lifetime of the original purchaser. Intentional misuse or abuse causing burn through of the cast iron components voids all warranties. Over-firing the furnace will cause the front face to crack and is not covered by the warranty. Furthermore, some cosmetic deterioration can be expected as the result of normal operation, therefore the physical appearance is not guaranteed to remain unchanged. The manufacturer warrants all electrical components for 1 year and the blower motor for 2 years. Please be advised that the firebrick and door gaskets are excluded from this warranty.

In order to exercise the aforementioned warranty, a certified professional must determine the appliance/part to be defective. He or she must submit a written statement to Fire Chief Furnace detailing an assessment of the problem. This assessment **MUST** be accompanied by substantiating proof of purchase (dated invoice, bill of sale, canceled check, or payment record), model, and serial number. Fire Chief Furnace will then authorize repair or replacement as appropriate to the submitted claim. Fire Chief Furnace will not honor expenses incurred from any action that was not expressly consented to in writing. The owner is hereby notified that he or she will be obligated to assume liability for removal, re-installation, shipping, and labor costs involved in servicing/repairing or replacing the part or unit. The merchandise in question must be shipped via PREPAID FREIGHT to Fire Chief Furnace. Fire Chief Furnace will return the repaired or replacement part to the purchaser on a FREIGHT COLLECT basis.

This warranty will be rendered null and void if this part/unit exhibits symptoms of obvious over-firing, deliberate abuse or negligence, improper installation, or is used for commercial purposes.

Finally, Fire Chief Furnace will not be responsible for any claim not stated in our warranty nor does any implied warranty extend beyond the limits stated above.

Please contact Fire Chief Furnace with all pertinent information including daytime phone number and detailed description of the type of problem you are having. Fire Chief Furnace's technical service personnel will contact you as soon as possible. Call 1-800-875-4788 or mail information to: HY-C Company, LLC | Furnace Division, 10950 Linpage Place, Saint Louis, MO 63132.

FOR ONLINE WARRANTY REGISTRATION VISIT: www.hy-c.com.



