



Fire Chief Wood/Coal Burning Furnaces

Indoor FC300F FC450 FC500E FC700E FC1100E

Outdoor FC1600D FC1800D FC2200D

WHY BUY A FIRE CHIEF FURNACE?

Fire Chief Furnaces are built to a high standard of manufacturing excellence. We have listened to the constructive critique of our loyal customers for 30 years. Who knows better than the consumer? Our units are built to stand the test of time using the best materials in the industry. Our Saint Louis-based company produces the #1 central wood/coal burning furnace in America. Don't take our word, ask a satisfied owner of a Fire Chief.



Easy to Use & Maintain

The Fire Chief furnaces are designed with ease-of-use in mind. Over the years we've perfected our furnaces so you can heat your home without worry or complications. The pre-wired electrical system is easy to attach - saving time and money. Many units come standard with automatic draft control and digital wall thermostats. More than 95% of our furnaces are self-installed.

Maximum Efficiency & Maximum Heat

Our furnace has the strongest blower in the industry (1/3-horsepower compared with the industry standard 1/8-horsepower and 1/10-horsepower units). Fire Chief delivers faster and stronger air flow. Our unique secondary combustion chamber ensures higher efficiency, re-burning wood gases and smoke. The multi-directional cast iron baffles direct combustion air above and below the grates to create maximum efficiency. In addition, burning wood (a renewable resource) reduces greenhouse gas emissions caused by burning fossil fuels such as oil, propane, and gas.

Highest Quality Standards

Fire Chief has the best warranty in the industry. Our unique 360-degree cast iron roller grate system allows for separation of fine ash and carries a limited lifetime warranty. Our blower motors have a 2-year warranty and fire boxes a 5-year warranty. Fire Chief furnaces are made entirely in the USA. All furnaces are tested to the UL391 standard by Intertek. For our outdoor units, the patented heat dump safety feature makes a Fire Chief the most reliable furnace you can buy.

Reliable Support Network

We partner with our dealer network to provide training and support throughout the season. Fire Chief does not outsource Customer Technical Support services. Our toll free number is answered by trained support team members in St. Louis, Missouri.

FC300F INDOOR

WOOD & COAL BURNING - TESTED TO UL391
HEATING AREA = 1200 SQ FT
MAXIMUM BTUs = 80,000

LOG SIZE = 22"
FIREBOX = 4.8 CUBIC FT
BLOWER CAPACITY = 490 CFM

FIREBOX = 5 YEAR WARRANTY
OPTIONAL FILTER BOX = 16" x 20" x 1"
MANUAL DRAFT CONTROL

PRE-WIRED FOR EASY ASSEMBLY
SHIPPING WEIGHT = 320 LBS



FC450 INDOOR

WOOD & COAL BURNING - TESTED TO UL391
HEATING AREA = 1500-2000 SQ FT
MAXIMUM BTUs = 100,000

LOG SIZE = 22"
FIREBOX = 7.1 CUBIC FT
BLOWER CAPACITY = 1500 CFM

FIREBOX = 5 YEAR WARRANTY
STANDARD FILTER BOX = 20" x 25" x 1"
BI-METAL THERMOSTAT DRAFT CONTROL

PRE-WIRED FOR EASY ASSEMBLY
SHIPPING WEIGHT = 505 LBS



FC500E INDOOR

WOOD & COAL BURNING - TESTED TO UL391
HEATING AREA = 1500-2000 SQ FT
MAXIMUM BTUs = 100,000

LOG SIZE = 22"
FIREBOX = 7.1 CUBIC FT
BLOWER CAPACITY = 1350, 1500, 1800 CFM

FIREBOX = 5 YEAR WARRANTY
STANDARD FILTER BOX = 20" x 25" x 1"
DIGITAL WALL THERMOSTAT DRAFT CONTROL

PRE-WIRED FOR EASY ASSEMBLY
SECONDARY COMBUSTION CHAMBER
SHIPPING WEIGHT = 555 LBS

CAST IRON ROLLER GRATES = LIFETIME WARRANTY



FC700E INDOOR

WOOD & COAL BURNING - TESTED TO UL391
HEATING AREA = 2500-3500 SQ FT
MAXIMUM BTUs = 150,000

LOG SIZE = 28"
FIREBOX = 8.9 CUBIC FT
BLOWER CAPACITY = 1350, 1500, 1800 CFM

FIREBOX = 5 YEAR WARRANTY
STANDARD FILTER BOX = 20" x 25" x 1"
DIGITAL WALL THERMOSTAT DRAFT CONTROL

PRE-WIRED FOR EASY ASSEMBLY
SECONDARY COMBUSTION CHAMBER
SHIPPING WEIGHT = 615 LBS

CAST IRON ROLLER GRATES = LIFETIME WARRANTY



FC1100E INDOOR

WOOD & COAL BURNING - TESTED TO UL391

HEATING AREA = 3500-5000 SQ FT

MAXIMUM BTUs = 200,000

LOG SIZE = 34"

FIREBOX = 11.3 CUBIC FT

BLOWER CAPACITY = 1350, 1500, 1800 CFM

FIREBOX = 5 YEAR WARRANTY

STANDARD FILTER BOX = 20" x 25" x 1"

DIGITAL WALL THERMOSTAT DRAFT CONTROL

PRE-WIRED FOR EASY ASSEMBLY

SECONDARY COMBUSTION CHAMBER

SHIPPING WEIGHT = 705 LBS

CAST IRON ROLLER GRATES = LIFETIME WARRANTY



FC1600D OUTDOOR

WOOD & COAL BURNING - TESTED TO UL391

HEATING AREA = 1000-1500 SQ FT

MAXIMUM BTUs = 100,000

LOG SIZE = 28"

FIREBOX = 5.9 CUBIC FT

BLOWER CAPACITY = 1800 CFM

FIREBOX = LIMITED 5 YEAR WARRANTY

MANUAL DRAFT CONTROL

PRE-WIRED FOR EASY ASSEMBLY

SECONDARY COMBUSTION CHAMBER

SHIPPING WEIGHT = 590 LBS

25 FT FLEX HEAT DUCT



FC1800D OUTDOOR

WOOD & COAL BURNING - TESTED TO UL391

HEATING AREA = 1500-2500 SQ FT

MAXIMUM BTUs = 140,000

LOG SIZE = 28"

FIREBOX = 8.9 CUBIC FT

BLOWER CAPACITY = 1800 CFM

FIREBOX = LIMITED 5 YEAR WARRANTY

DIGITAL WALL THERMOSTAT DRAFT CONTROL

PRE-WIRED FOR EASY ASSEMBLY

SECONDARY COMBUSTION CHAMBER

SHIPPING WEIGHT = 780 LBS

25 FT FLEX HEAT DUCT



FC2200D OUTDOOR

WOOD & COAL BURNING - TESTED TO UL391

HEATING AREA = 2500-3500 SQ FT

MAXIMUM BTUs = 180,000

LOG SIZE = 34"

FIREBOX = 10.8 CUBIC FT

BLOWER CAPACITY = 1800 CFM

FIREBOX = LIMITED 5 YEAR WARRANTY

DIGITAL WALL THERMOSTAT DRAFT CONTROL

PRE-WIRED FOR EASY ASSEMBLY

SECONDARY COMBUSTION CHAMBER

SHIPPING WEIGHT = 865 LBS

25 FT FLEX HEAT DUCT



300

MODEL

FC300F

BTUs (maximum) HEATING (sq. ft.) LOG SIZE	80,000 APPROX. UP TO 1200 22"
FIRE BOX VOLUME BLOWER CAPACITY DOOR SIZE	4.8 CU. FT. 490 CFM 13" x 14"
FLUE SIZE PLENUM SIZE HEIGHT TO CENTER OF FLUE COLLAR	6" 8" ROUND 35.25"
FILTER SIZE HEIGHT x WIDTH DEPTH (with optional filter box)	16" x 20" x 1" 40.5" x 20" 41"
SHIPPING WEIGHT WARRANTY - FIREBOX WARRANTY - GRATES & CASTINGS WARRANTY - BLOWER MOTOR	320 LBS. 5 YEAR LIMITED 5 YEAR LIMITED 2 YEAR



FURNACE FEATURES

- Wood Grate System
- Prewired Electrical System
- 490 CFM Blower Motor
- Optional Filter Box
- Heavy Gauge Continuously Welded Steel Fire Box
- Manually Controlled Draft System
- Removable Ash Pan

ACCESSORIES



450

MODEL

FC450

BTUs (maximum) HEATING (sq. ft.) LOG SIZE	100,000 APPROX. 1500-2000 22"
FIRE BOX VOLUME BLOWER CAPACITY DOOR SIZE	7.1 CU. FT. 1500 CFM 13" x 14"
FLUE SIZE PLENUM SIZE HEIGHT TO CENTER OF FLUE COLLAR	6" 10" ROUND 44.5"
FILTER SIZE HEIGHT x WIDTH DEPTH (with filter box)	20" x 25" x 1" 50.5" x 26" 45"
SHIPPING WEIGHT WARRANTY - FIREBOX WARRANTY - GRATES & CASTINGS WARRANTY - BLOWER MOTOR	505 LBS. 5 YEAR LIMITED 5 YEAR LIMITED 2 YEAR



FURNACE FEATURES

- Wood Grate System
- Prewired Electrical System
- 1/3 Horsepower 1500 CFM Blower Motor
- Filter Box Standard
- Heavy Gauge Continuously Welded Steel Fire Box
- Bi-Metal Thermostatically Controlled Draft System Provides Automatic Combustion Control

ACCESSORIES



10" BACK DRAFT DAMPER

AM-BD10



10" GALVANIZED ELBOW

SNG90-10

10"x 24" GALVANIZED PIPE

SNGP24x10

500 700 1

MODEL	FC500E	FC700E	FC1100E
BTUs (maximum) HEATING (sq. ft.) LOG SIZE	100,000 APPROX. 1500-2000 22"	150,000 APPROX. 2500-3500 28"	200,000 APPROX. 3500-5000 34"
FIRE BOX VOLUME DIGITAL THERMOSTAT INDUCTION DRAFT BLOWER	7.1 CU. FT. INCLUDED 50 CFM	8.9 CU. FT. INCLUDED 50 CFM	11.3 CU. FT. INCLUDED 50 CFM
3-SPEED BLOWER CAPACITY DOOR SIZE FLUE SIZE	1350, 1500, 1800 CFM 13" x 14" 6"	1350, 1500, 1800 CFM 13" x 14" 6"	1350, 1500, 1800 CFM 13" x 14" 8"
PLENUM SIZE HEIGHT TO CENTER OF FLUE COLLAR FILTER SIZE	12" ROUND 44.5" 20" x 25" x 1"	12" ROUND 44.5" 20" x 25" x 1"	12" ROUND 44.5" 20" x 25" x 1"
HEIGHT x WIDTH DEPTH (with filter box) SHIPPING WEIGHT	50.5" x 26" 45" 555 LBS.	50.5" x 26" 51" 615 LBS.	50.5" x 26" 56" 705 LBS.
WARRANTY - FIREBOX WARRANTY - GRATES & CASTINGS WARRANTY - ELECTRICAL & BLOWER	5 YEAR LIFETIME 2 YEAR	5 YEAR LIFETIME 2 YEAR	5 YEAR LIFETIME 2 YEAR

ACCESSORIES



12"x24" GALVANIZED PIPE SNG24X12

TYPICAL INDOOR FURNACE INSTALLATION

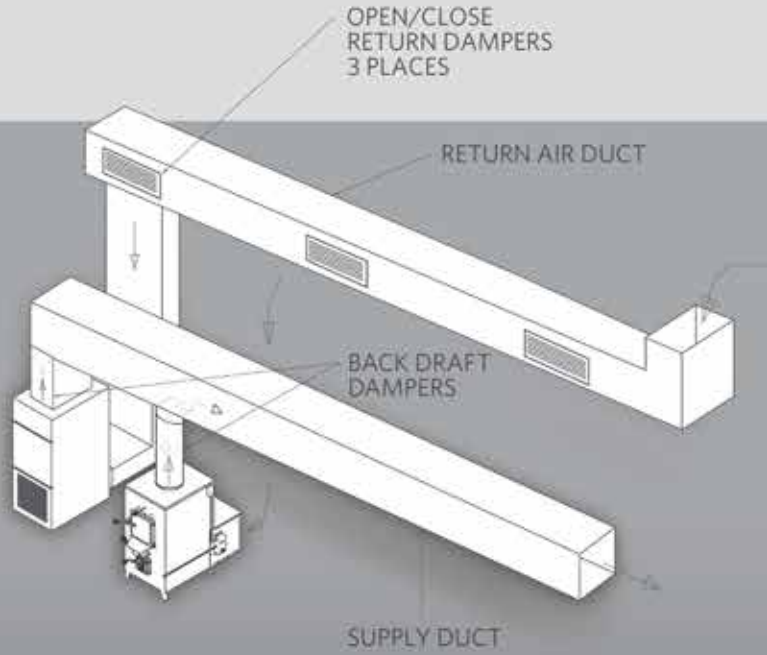

100

- Best Warranty in the Industry
- 360° Cast Iron Roller Grate
- Prewired Electrical System
- 1/3 Horsepower 3-Speed Blower Motor
- Standard Filter Box
- 7 & 10 Gauge Steel Fire Box
- Secondary Combustion Chamber
- Thermostatically Controlled Draft System



FURNACE FEATURES

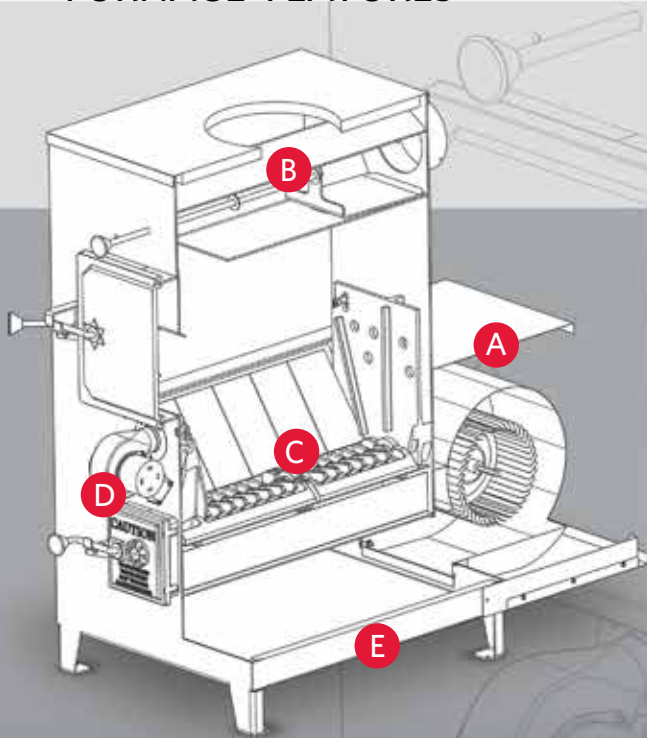

- A** Standard Filter Box (Blower Motor)
- B** Secondary Combustion Chamber
- C** 360° Cast Iron Roller Grate
- D** Induction Draft Blower
- E** Insulated Sides

16000

MODEL **FC1600D**

BTUs (maximum) HEATING (sq. ft.) LOG SIZE	100,000 APPROX. 1000-1500 28"
FIRE BOX VOLUME BLOWER CAPACITY DOOR SIZE	5.9 CU. FT. 1800 CFM 13" x 14"
FLUE SIZE PLENUM SIZE COLD AIR RETURN	6" 10" ROUND 12" ROUND
HEIGHT WIDTH DEPTH (w/blower housing)	44.5" 29.5" 60"
SHIPPING WEIGHT WARRANTY - FIREBOX WARRANTY - ELECTRICAL COMPONENTS	590 LBS 5 YEAR LIMITED 1 YEAR
WARRANTY - BLOWER MOTOR 10" INSULATED HEAT DUCT	2 YEAR 25 FT.

TYPICAL OUTDOOR FURNACE INSTALLATION

ACCESSORIES (for all Outdoor units)

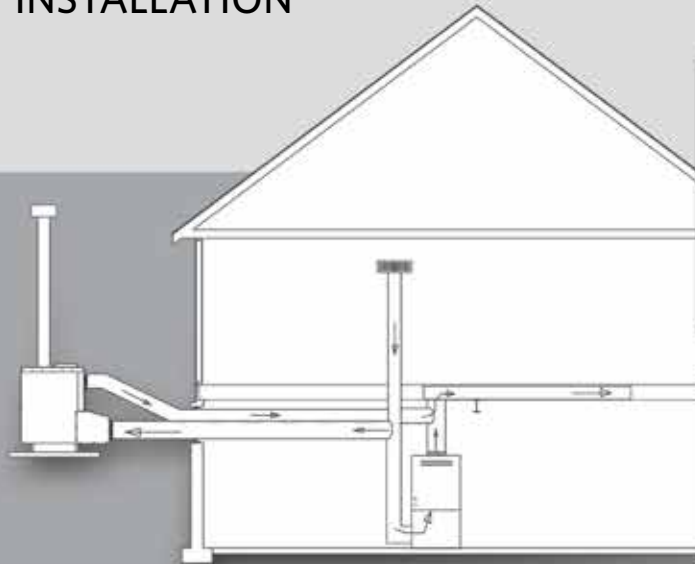

- Patented Heat Dump
- Prewired Electrical System
- 7 & 10 Gauge Steel Fire Box
- Secondary Combustion Chamber
- 1/3 Horsepower 1800 CFM Blower Motor
- Manually Controlled Draft System
- Laser Cut Grate for Easy Ash Removal
- Optional Return Air Filter Box

**PATENTED
HEAT DUMP**
PROTECTS ADD-ON
FURNACE IN CASE OF
POWER LOSS



FURNACE FEATURES

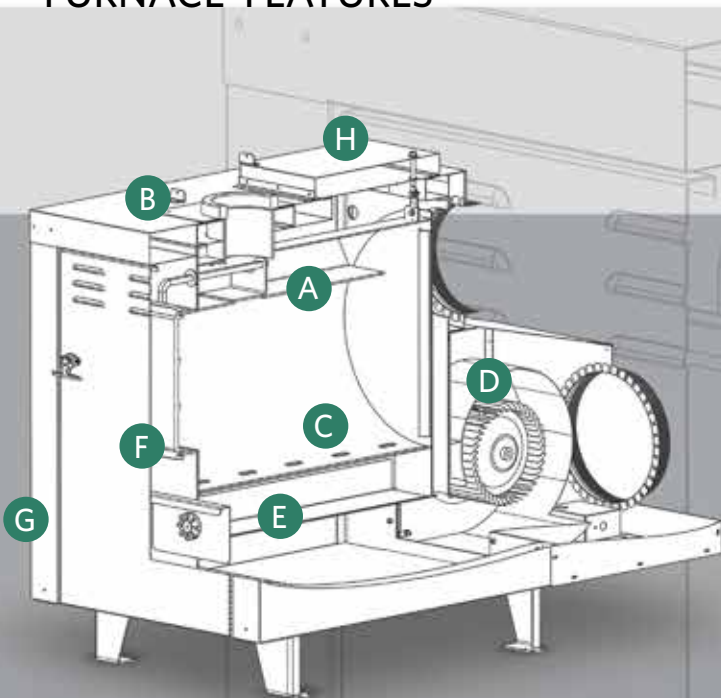

- A** Secondary Combustion Chamber
- B** Anchor Plate for Insulated Chimney
- C** Laser Cut Ash Grate System
- D** Thermostatically Controlled 1800 CFM Blower
- E** Removable Ash Pan with Spin Draft
- F** Manual Draft Control
- G** Durable Powder Coated Weather-Resistant Finish
- H** Patented Heat Dump

MODEL

FC1800D

FC2200D

BTUs (maximum) HEATING (sq. ft.) LOG SIZE	140,000 APPROX. 1500-2500 28"	180,000 APPROX. 2500-3500 32"
PLENUM SIZE DIGITAL THERMOSTAT INDUCTION DRAFT BLOWER	10" ROUND INCLUDED 50 CFM	10" ROUND INCLUDED 50 CFM
BLOWER CAPACITY DOOR SIZE FLUE SIZE	1800 CFM 13" x 14" 6"	1800 CFM 13" x 14" 6"
FIRE BOX VOLUME HEIGHT x WIDTH DEPTH (w/blower housing)	8.9 CU. FT. 59" x 30" 59"	10.8 CU. FT. 59" x 30" 65"
10" INSULATED HEAT DUCT COLD AIR RETURN SHIPPING WEIGHT	25 FT. 12" ROUND 780 LBS.	25 FT. 12" ROUND 865 LBS.
WARRANTY - FIREBOX WARRANTY - GRATES & CASTING WARRANTY - ELECTRICAL & BLOWER	5 YEAR LIMITED 5 YEAR LIMITED 2 YEAR	5 YEAR LIMITED 5 YEAR LIMITED 2 YEAR

FURNACE FEATURES

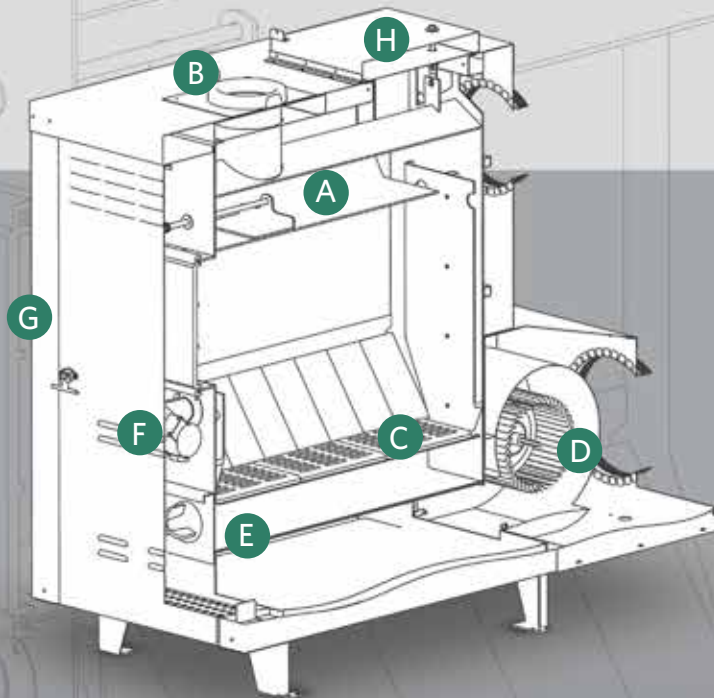

- A** Secondary Combustion Chamber
- B** Anchor Plate for Insulated Chimney
- C** Wood Grates
- D** 1800 CFM Blower Motor
- E** Removable Ash Pan with Spin Draft
- F** Induction Draft Blower
- G** Durable Powder Coated Weather-Resistant Finish
- H** Patented Heat Dump

**PATENTED
HEAT DUMP**
PROTECTS ADD-ON
FURNACE IN CASE OF
POWER LOSS

- Patented Heat Dump
- Prewired Electrical System
- 7 & 10 Gauge Steel Fire Box
- Secondary Combustion Chamber
- Thermostatically Controlled Draft System
- 1/3 Horsepower 1800 CFM Blower Motor
- Optional Return Air Filter Box



ACCESSORIES (for all Outdoor units)



10" BACK DRAFT DAMPER

AM-BD10

12" BACK DRAFT DAMPER

AM-BD12



10" MANUAL BACK DRAFT DAMPER

AM-MD10

12" MANUAL BACK DRAFT DAMPER

AM-MD12



MOBILE HOME KIT

FCMHK



10" STARTER COLLAR

SNGCLR10

8" STARTER COLLAR

SNGCLR08

12" STARTER COLLAR

SNGCLR12



RETURN AIR FILTER BOX

FCOSFB

- filter size 16"x20"x1"

- interior use only



12"x 25' INSULATED FLEX DUCT

SF12HDK



QUALITY PRODUCTS

OTHER QUALITY PRODUCTS FROM OUR COMPANY

CHIMNEY COVERS

Protect your chimney from cracks and deterioration and keep it free from pests and debris. Single flue and multi-flue available. Superior construction available in Copper, Stainless Steel and Galvanized Steel. Limited lifetime warranty for Copper and Stainless Steel, 7-year warranty on Galvanized Steel.

Custom-Made Chimney Covers also available. Call 1-800-325-7076.



STOVE BOARDS

Protect your floors or walls from intense heat, hot coals and ashes. Use under heating appliances, on the wall behind the appliance, or in front of your fireplace. These UL1618 Type 2 Stove Boards are available in 4 updated patterns.



LOG RACKS & COVERS

Cure your wood to produce maximum BTUs during the heating season. Available in a variety of styles and adjustable sizes, constructed of heavy-duty tubular or 1.25" square 16 gauge steel, with a black powder coat finish. Easy to assemble. Log rack covers also available.



LOG GRATES

Enhance the look and usefulness of your fireplace with these durable cast iron grates. They are offered in a variety of styles and sizes to suit every taste and fireplace size.



FLEX LINER KIT

Highly recommended to protect your home from flue fires and creosote build up, the flex liner kit is made from 7-ply 316 stainless steel to provide superior strength and durability. Rugged construction allows for expansion and contraction during heat up and cool down periods. Limited lifetime warranty.



CLASS "A" CHIMNEY

ShelterPro Chimney is designed to handle temperatures up to 2100°F with superior durability and safety. The inner liner and outer casing are outstanding grade 304 stainless steel, designed to prevent corrosion and keep out moisture. Premium fiber insulation ensures minimal loss of heat. Offered in 6" and 8" diameters and a variety of lengths, includes a lifetime warranty.



FIRE CHIEF



a HY-C Company

WWW.FIRECHIEFWOODFURNACE.COM

800-875-4788