

Wood Stove Owner's Manual

Part 1 of 2

SAFETY NOTIFICATIONS AND GENERAL INFORMATION

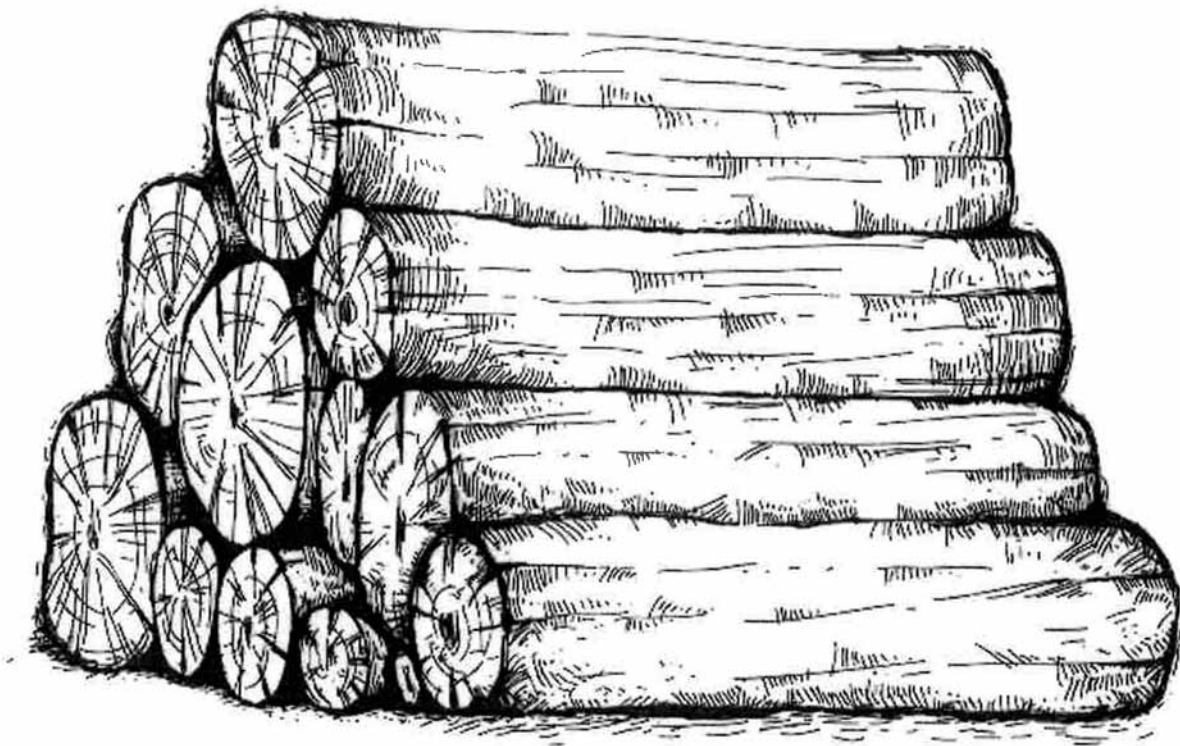

ENGLISH

CONTACT LOCAL BUILDING OR FIRE OFFICIALS ABOUT RESTRICTIONS AND INSTALLATION INSPECTION REQUIREMENTS IN LOCAL AREA.

READ THIS ENTIRE GUIDE BEFORE INSTALLATION AND USE OF THIS WOOD STOVE. FAILURE TO FOLLOW THESE INSTRUCTIONS COULD RESULT IN PROPERTY DAMAGE, BODILY INJURY OR EVEN DEATH.

READ AND KEEP THIS GUIDE FOR REFERENCE

THANK YOU FOR CHOOSING THIS WOOD STOVE.

If this room heater is not properly installed, a house fire may result.

To reduce the risk of fire, follow the installation instructions in this manual.

As one of North America's largest and most respected wood stove and fireplace manufacturers, Stove Builder International takes pride in the quality and performance of all its products.

The following pages provide general advice on wood heating, detailed instructions for safe and effective installation, and guidance on how to get the best performance from this stove.

It is highly recommended that this wood burning hearth product be installed and serviced by professionals who are certified by a «Qualified Agency» such as NFI (National Fireplace Institute®) or CSIA (Chimney Safety Institute of America) in the United States and in Canada by WETT (Wood Energy Technology Transfer) or in Quebec by APC (Association des Professionnels du Chauffage).

Contact local building or fire officials about restrictions and installation inspection requirements in your local area.

A building permit might be required for the installation of this stove and the chimney that it is connected to. It is also highly recommended to inform your home insurance company.

Please read this entire manual before installing and using this stove.

A primary alternative heat source should be available in the home. This heating unit may serve as a supplementary heat source. The manufacturer cannot be responsible for additional heating costs associated with the use of an alternative heat source.

TABLE OF CONTENTS

1. Safety Information and Environment	5
1.1 Mobile Home.....	6
1.2 Regulations Covering Stove Installation.....	7
1.3 Location of the Certification Label	7
1.4 Emissions and Efficiency.....	8
1.5 Materials.....	8
2. Fuel.....	9
2.1 Tree Species	9
2.2 Log Length	10
2.3 Piece Size.....	10
2.4 Compressed Wood Logs.....	10
2.5 Drying Time	10
3. Burning Wood Efficiently	11
3.1 First Use.....	11
3.2 Lighting Fires	12
3.3 Zone Heating	13
3.4 Combustion Cycles.....	13
3.5 Rekindling a Fire	14
3.6 Removing Ashes.....	15
3.7 Air Intake Control	15
3.8 Fire Types	16
4. Maintenance.....	17
4.1 Heater	18
4.2 Refractory Materials and Baffle.....	18
4.3 Glass Door.....	18
5. Operating the Stove.....	19
5.1 Blower Operation	19
5.2 The Use of a Fire Screen	20
5.3 Exhaust System	20
6. The Venting System	22
6.1 General	22
6.2 Suitable Chimneys.....	22
6.3 Factory-Built Metal Chimneys	22
6.4 Minimum Chimney Height.....	24
6.5 Chimney Location.....	24
6.6 Supply of Combustion Air	25
6.7 Installing the Chimney Connector	26

1. Safety Information and Environment

- Some stoves have been tested for use with an open door in conjunction with a fire screen, sold separately (See in the *Wood Stove Installation and Operation Manual* if your appliance has this option). The door may be opened, or fire screen removed only during lighting procedures or reloading. Always close the door or put back on the fire screen after ignition. **Do not leave the insert unattended when the door is open with or without a fire screen.**
- **WARNING : OPERATE ONLY WITH THE DOOR FULLY CLOSED OR FULLY OPEN WITH THE FIRE SCREEN IN PLACE. IF THE DOOR IS LEFT PARTLY OPEN, GAS AND FLAME MAY BE DRAWN OUT OF THE OPENING, CREATING RISKS FROM BOTH FIRE AND SMOKE.**
- **WARNING: ALWAYS OPERATE THE STOVE WITH THE ASH DRAWER CLOSED.**
- **HOT WHILE IN OPERATION, KEEP CHILDREN, CLOTHING AND FURNITURE AWAY. CONTACT MAY CAUSE SKIN BURNS. GLOVES MAY BE NEEDED FOR THE STOVE OPERATION.**
- Using a stove with cracked or broken components, such as glass, firebricks or baffle may produce an unsafe condition and may damage the stove.
- Open the air control fully before opening the loading door.
- **DO NOT BURN GARBAGE OR FLAMMABLE FLUIDS SUCH AS GASOLINE, NAPHTA OR ENGINE OIL.**
- Do not store fuel within heater minimum installation clearances.
- Burn only seasoned natural firewood.
- This appliance should always be maintained and operated in accordance with these instructions.
- Do not elevate the fire by using a grate.
- Do not use makeshift materials or make any compromises when installing this appliance.
- This wood heater needs periodic inspection and repairs for the proper operation. It is against federal regulations to operate this wood heater in a manner inconsistent with operating instructions in this guide.
- A smoke detector, a carbon monoxide detector and a fire extinguisher should be installed in the house. The location of the fire extinguisher should be known by all family members.
- A smoke detector located in the proximity of the stove may be activated when the door of the stove is open to reload or to stir.



This product can expose you to chemicals including carbon monoxide, which is known to the State of California to cause cancer, birth defects or other reproductive harm. For more information go to www.P65warnings.ca.gov/

- The information given on the certification label affixed to the appliance always overrides the information published, in any other media (owner's manual, catalogues, flyers, magazines and web sites).

- Mixing of appliance components from different sources or modifying components may result in hazardous conditions. Where any such changes are planned, Stove Builder International Inc. should be contacted in advance.
- Any modification of the appliance that has not been approved in writing by the testing authority violates CSA-B365 (Canada), and ANSI NFPA 211 (USA).
- **CAUTION: DO NOT CONNECT TO OR USE IN CONJUNCTION WITH ANY AIR DISTRIBUTION DUCTWORK UNLESS SPECIFICALLY APPROVED FOR SUCH INSTALLATION.**
- **CAUTION: DO NOT CONNECT THIS UNIT TO A CHIMNEY FLUE SERVING ANOTHER APPLIANCE.**
- Connect this stove only to a listed factory-built chimney for use with solid fuel or to a lined masonry chimney conforming to national and local building codes.
- If required, a supply of combustion air shall be provided to the room.
- This stove must be installed as a free-standing heater with the clearances listed in the manufacturer's installation instructions. It is strictly forbidden to install this stove in a factory-built fireplace.
- **NOTE: DO NOT INSTALL THE CHIMNEY DIRECTLY AT THE OUTLET OF THE APPLIANCE. A CHIMNEY CONNECTOR (FLUE PIPE) IS REQUIRED UNLESS THE APPLIANCE IS SPECIFICALLY APPROVED FOR THAT TYPE OF INSTALLATION.**

1.1 Mobile Home

- Some appliances may be installed in a mobile home. The installation requires a fresh air kit, sold separately.
- **WARNING : DO NOT INSTALL IN THE SLEEPING ROOM OF A MOBILE HOME.**
- **IF INSTALLATION OF THIS PRODUCT IS PERMITTED IN A MOBILE HOME, IT MUST BE SECURED TO THE STRUCTURE.**
- **CAUTION : WHEN THE INSTALLATION IN A MOBILE HOME IS ACCEPTED, THE STRUCTURAL INTEGRITY OF THE MOBILE HOME FLOOR, WALL, CEILING AND ROOF MUST BE MAINTAINED.**
- **IT IS PROHIBITED TO USE THIS WOOD STOVE WITH A FIRE SCREEN IN A MOBILE HOME.**

1.2 Regulations Covering Stove Installation

When installed and operated as described in these instructions, this wood stove is suitable for use as a freestanding heater in residential installations.

In Canada, the CSA-B365 *Installation Code for Solid Fuel Burning Appliances and Equipment* and the CSA-C22.1 *Canadian National Electrical Code* are to be followed in the absence of local code requirements. In the USA, the ANSI NFPA 211 *Standard for Chimneys, Fireplaces, Vents and Solid Fuel-Burning Appliances* and the ANSI NFPA 70 *National Electrical Code* are to be followed in the absence of local code requirements.

This stove must be connected to a chimney complying with the requirements for Type HT chimneys in the *Standard for Factory-Built Chimneys for Residential Type and Building Heating Appliances*, UL 103HT and ULC S629 or to a code-approved masonry chimney with a flue liner.

1.3 Location of the Certification Label

Since the information given on the certification label affixed to the appliance always overrides the information published, in any other media (owner's manual, catalogues, flyers, magazines and web sites) it is important to refer to it in order to have a safe and compliant installation. In addition, important information about the stove can be found (model, serial number, etc.). The certification label is located on the back of the stove.

It is recommended to note the stove serial number on page 1 of the *Wood Stove Installation and Operation Manual* since it will be needed to precisely identify the version of the appliance in the event replacement parts or technical assistance is required.

1.4 Emissions and Efficiency

The low smoke emissions produced by the special features inside this stove firebox mean that the household will release up to 90% less smoke into the outside environment than if an older conventional stove was used. But there is more to the emission control technologies than protecting the environment.

The smoke released from wood when it is heated contains about half of the energy content of the fuel. By burning the wood completely, this stove releases all the heat energy from the wood instead of wasting it as smoke up the chimney. Also, the features inside the firebox allow control of the air supply meaning controlling the heat output, while maintaining clean and efficient flaming combustion, which boosts the efficient delivery of heat to the home.

The emission control and advanced combustion features of this stove can only work properly if the fuel used is in the correct moisture content range of 15% to 20%. Refer to the [Fuel Section](#) for suggestions on preparing fuelwood and judging its moisture.

1.5 Materials

The SBI team is committed to protecting the environment, so they do everything they can to use only materials in their products that will have no lasting negative impact on the environment.

The **body** of this stove, which is most of its weight, is carbon steel. Should it ever become necessary many years in the future, almost the entire stove can be recycled into new products, thus eliminating the need to mine new materials.

The **paint** coating on the stove is very thin. Its VOC content (Volatile Organic Compounds) is very low. VOCs can be responsible for smog, so all the paint used during the manufacturing process meets the latest air quality requirements regarding VOC reduction or elimination.

The **air tubes** are stainless steel, which can also be recycled.

The **baffle** is made of aluminosilicate fibre material that is compressed with a binder to form a rigid board. C-Cast or Vermiculite can withstand temperatures above 2,000 °F. It is not considered hazardous waste. Disposal at a ecocenter is recommended.

The **Grey firebrick** is made of cement and pumice stone. Pumice stone is made from volcanic rock. It is recommended to send it to the ecocenter.

The **Yellow firebrick** is mainly composed of silicon dioxide, also known as silica, a product processed from a mined mineral. It is most commonly found in nature in the form of sand and clay. Disposal at a ecocenter is recommended.

The door and glass **gaskets** are fibreglass which is spun from melted sand. Black gaskets have been dipped into a solvent-free solution. Disposal at a ecocenter is recommended.

The door **glass** is a 5/32" (4 mm) thick ceramic material that contains no toxic chemicals. It is made of natural raw materials such as sand and quartz that are combined in such a way to form a high temperature glass. Ceramic glass cannot be recycled in the same way as normal glass, so it should not be disposed of with your regular household products. Disposal at a ecocenter is recommended.

2. Fuel

Good firewood has been cut to the correct length for the stove, split to a range of sizes and stacked in the open until its moisture content is down to 15% to 20%.

DO NOT BURN:

- **COAL;**
- **GARBAGE;**
- **LAWN CLIPPINGS OR YARD WASTE;**
- **MATERIALS CONTAINING RUBBER, INCLUDING TIRES;**
- **MATERIALS CONTAINING PLASTIC;**
- **WASTE PETROLEUM PRODUCTS, PAINTS OR PAINT THINNERS, OR ASPHALT PRODUCTS;**
- **MATERIALS CONTAINING ASBESTOS;**
- **CONSTRUCTION OR DEMOLITION DEBRIS;**
- **RAILROAD TIES OR PRESSURE-TREATED WOOD;**
- **MANURE OR ANIMAL REMAINS;**
- **SALT WATER DRIFTWOOD OR OTHER PREVIOUSLY SALT WATER SATURATED MATERIALS;**
- **UNSEASONED WOOD; OR**
- **PAPER PRODUCTS, CARDBOARD, PLYWOOD, OR PARTICLE BOARD. THE PROHIBITION AGAINST BURNING THESE MATERIALS DOES NOT PROHIBIT THE USE OF FIRE STARTERS MADE FROM PAPER, CARDBOARD, SAW DUST, WAX AND SIMILAR SUBSTANCES FOR THE PURPOSE OF STARTING A FIRE IN AN AFFECTED WOOD HEATER.**
- **BURNING THESE MATERIALS MAY RESULT IN THE RELEASE OF TOXIC FUMES OR RENDER THE HEATER INEFFECTIVE AND CAUSE SMOKE.**
- **IF THESE FUELS ARE BURNED, IT COULD CREATE A HIGHER CONCENTRATION OF CO THAN BURNING HARDWOOD.**

2.1 Tree Species

The tree species the firewood is produced from is less important than its moisture content. The main difference in firewood from various tree species is the density of the wood. Hardwoods are denser than softwoods.

Homeowners with access to both hardwood and softwood use both types for different purposes.

Softer woods make good fuel for mild weather in spring and fall because they light quickly and produce less heat. Softwoods are not as dense as hardwoods so a given volume of wood contains less energy. Using softwoods avoids overheating the house, which can be a common problem with wood heating in moderate weather. Harder woods are best for colder winter weather when more heat and longer burn cycles are desirable.

Note that hardwood trees like oak, maple, ash and beech are slower growing and longer lived

than softer woods like poplar and birch. That makes hardwood trees more valuable. The advice that only hardwoods are good to burn is outdated. Old, leaky cast iron stoves wouldn't hold a fire overnight unless they were fed large pieces of hardwood. That is no longer true.

2.2 Log Length

Logs should be cut at least 1" (25 mm) shorter than the firebox so they fit in easily. Pieces that are even slightly too long makes loading the stove very difficult. The most common standard length of firewood is 16" (400 mm).



2.3 Piece Size

Firewood dries more quickly when it is split. Large unsplit rounds can take years to dry enough to burn. Even when dried, unsplit logs are difficult to ignite because they don't have the sharp edges where the flames first catch.

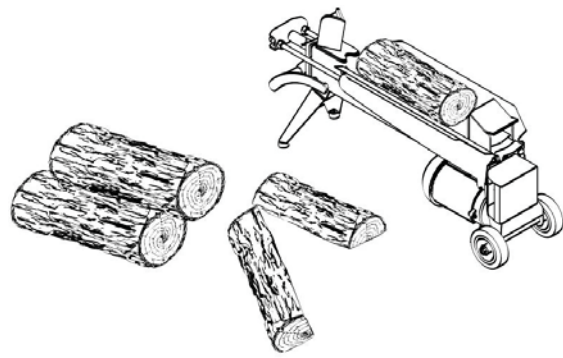
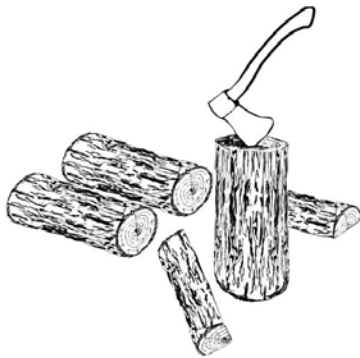

Wood should be split to a range of sizes, from about 3" to 6" (75 mm to 150 mm) in cross section. Having a range of sizes makes starting and rekindling fires much easier.

2.4 Compressed Wood Logs

Compressed wood logs made of 100% compressed sawdust can be burned with caution in the number of these logs burned at once. Do not burn compressed logs made of wax impregnated sawdust or logs with any chemical additives. Follow the manufacturer's instructions and warnings.

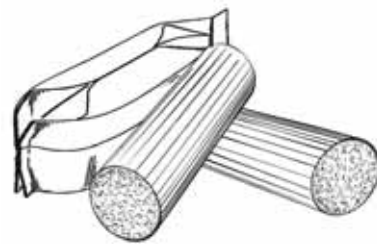

2.5 Drying Time

Firewood that is not dry enough to burn is the cause of most complaints about wood burning appliances. Continually burning green or unseasoned wood produces more creosote and involves lack of heat and dirty glass door. Firewood with a moisture content between 15% and 20% will allow the stove to produce its highest possible efficiency.

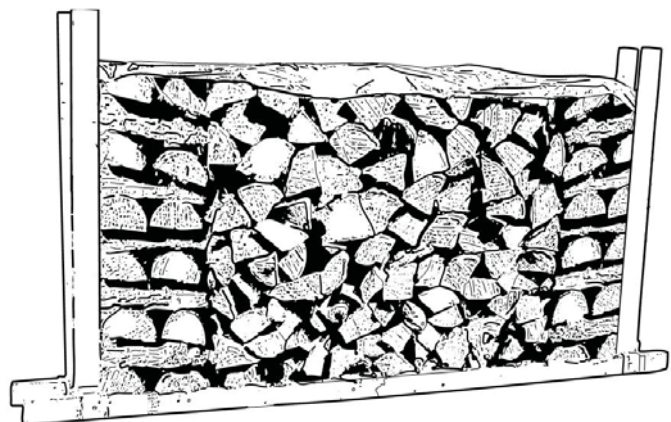

Here are some facts to consider in estimating drying time:

- Firewood bought from a dealer is rarely dry enough to burn, so it is advisable to buy the wood in spring and dry it yourself;
- Drying happens faster in dry weather than in a damp climate;
- Drying happens faster in warm summer weather than in winter weather;
- Small pieces dry more quickly than large pieces;
- Split pieces dry more quickly than unsplit rounds;
- Softwoods like pine, spruce, poplar, and aspen take less time to dry than hardwoods. they can be dry enough to burn after being stacked to air dry only for the summer months;
- Hardwoods like oak, maple and ash can take one, or even two years to dry fully, especially if the pieces are big;
- Firewood dries more quickly when stacked outside in a location exposed to sun and wind; it takes much longer to dry when stacked in a wood shed;

Use these guidelines to find out if the firewood is dry enough to burn:

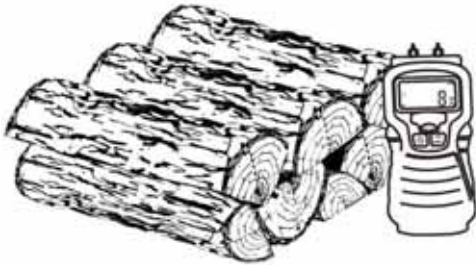

- Cracks form at the ends of logs as they dry;
- The wood turns from white or cream colored to grey or yellow;
- Two pieces of wood struck together sounds hollow;
- Dry wood is much lighter in weight than wet wood,
- The face of a fresh cut feels warm and dry;
- The moisture content read by a moisture meter is between 15% to 20%.

3. Burning Wood Efficiently

3.1 First Use

Two things happen when burning the first few fires; the paint cures and the internal components are conditioned. As the paint cures, some of the chemicals vaporize. The vapors are not poisonous, but they smell bad. Fresh paint fumes can also trigger false alarms in smoke detectors. When lighting the heater for the first few times, it may be wise to open doors and windows to ventilate the house.

Burn two or three small fires to begin the curing and conditioning process. Then build bigger and hotter fires until there is no longer paint smell from the stove. As hotter and hotter fires are burned, more of the painted surfaces reach the curing temperature of the paint. The smell of curing paint does not disappear until one or two very hot fires have been burned.

Never built the fire too close to the glass. It may cause higher temperature and produce a faster aging of the glass.

3.2 Lighting Fires

Each person heating with wood develops its own favorite way to light fires. Regardless of the method chosen, the goal should be to have a hot fire burning, quickly. A fire that ignites fast produces less smoke and deposits less creosote in the chimney.



Never use gasoline, gasoline-type lantern fuel (naphtha), fuel oil, motor oil, kerosene, charcoal lighter fluid, or similar liquids or aerosols to start or 'freshen up' a fire in this wood stove. Keep all such liquids well away from the stove while it is in use.

Here are three popular and effective ways to ignite wood fires.

3.2.1 Conventional Method

The conventional method to build a wood fire is to crumple 5 to 10 sheets of newspaper and place them in the firebox and hold them in place with ten pieces of kindling wood. The kindling should be placed on and behind the newspaper.

Then add two or three small pieces of firewood. Open the air intake control completely and ignite the newspaper. Leave the door slightly ajar.

Once the fire has ignited, the door can be closed with the air control still fully open. When the kindling is almost completely burned, standard firewood pieces can be added.

Do not leave the heater unattended when the door is slightly open. Always close and latch the door after the fire ignites.

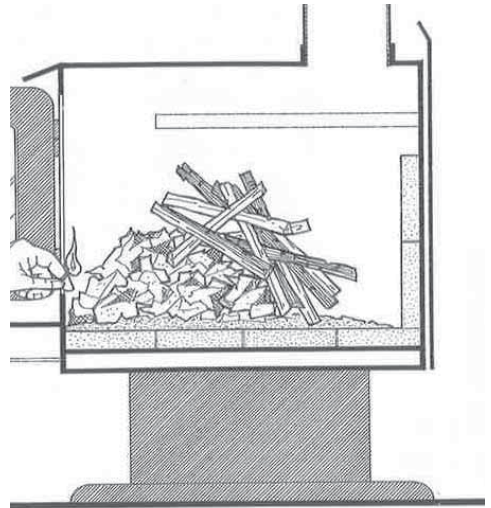

3.2.2 The Top Down Method

This method is the opposite of the conventional method and only works properly if well-seasoned wood is used.

Place three or four small, split, dry logs in the firebox. Arrange the kindling wood on the logs in two layers at right angles and place a dozen finely split kindling on the second row.

It is possible to use ragged paper but it may not hold in place since it tends to roll while it is burning. The best is to wrap a sheet on itself, grab the ends of the roll and make a knot. Use four or five sheets of paper tied together and put them on top and around the kindling. Open the air intake control completely, ignite the paper and close the door.

The top down fire method has two advantages over the traditional method: first, the fire does not collapse on itself, and it is not necessary to add wood gradually since the combustion chamber is full before the fire is lit.

3.2.3 Two Parallel Logs Method

Two spit logs are placed in the firebox with a few sheets of twisted newspapers in between the logs. Fine kindling is added across the two logs and some larger kindling across those, log cabin style. Newspaper is lit.

3.2.4 Using Fire Starters

Commercial fire starters can be used instead of a newspaper. Always follow the instructions on the packaging before use.

DO NOT USE CHEMICALS OR FLUID TO START THE FIRE.

NEVER USE GEL STARTER IF THERE ARE HOT EMBERS INSIDE THE FIREBOX. THE BOTTLE OF GEL WILL CATCH ON FIRE.

3.3 Zone Heating

This stove is a space heater, which means it is intended to heat the area it is installed in, as well as spaces that connect to that area, although to a lower temperature. This is called zone heating and it is an increasingly popular way to heat homes or spaces within homes.

Zone heating can be used to supplement another heating system by heating a particular space within a home, such as a basement, a family room or an addition that lacks another heat source.

Houses of moderate size and relatively new construction can be heated with a properly sized and located wood stove. Whole house zone heating works best when the stove is in the part of the house where the family spends most of its time. This is normally the main living area where the kitchen, dining and living rooms are located.

Locating the stove in this area will give the maximum benefit of the heat it produces and will achieve the highest possible heating efficiency and comfort. The space where the most time is spent will be warmest, while bedrooms and basement (if there is one) will stay cooler. In this way, less wood is burnt than with other forms of heating.

Although the stove may be able to heat the main living areas of the house to an adequate temperature, it is strongly recommended to also have a conventional oil, gas or electric heating system to provide backup heating.

The success of zone heating will depend on several factors, including the correct sizing and location of the stove, the size, layout and age of your home and your climate zone. Three-season vacation homes can usually be heated with smaller stoves than houses that are heated all winter.

3.4 Combustion Cycles

Wood heating with a space heater is very different than other forms of heating. There will be temperature variations in different parts of the house and there will be temperature variations throughout day and night. This is normal, and for experienced wood burners these are advantages of zone heating wood burning.

Wood heaters don't have a steady heat output. It is normal for the temperature to rise after a new load of wood is ignited and for its temperature to gradually decrease throughout the burning cycle. This increasing and decreasing temperature can be matched with the household routines. For example, the temperature in the area can be cooler when the household is active, and it can be warmer when it is inactive.

Wood burns best in cycles. A cycle starts when a new load of wood is ignited by hot coals and

ends when that load has been consumed down to a bed of charcoal about the same size as it was when the wood was loaded.

Trying to produce a steady heat output by placing a single log on the fire at regular intervals is not recommended. Always place at least three, and preferably more pieces on the fire at a time so that the heat radiated from one piece helps to ignite the pieces next to it. Each load of wood should provide several hours of heating. The size of each load may vary depending on the amount of heat required.

Burning in cycles means the loading door does not need to be opened while the wood is flaming. This is an advantage since it is preventing smoke leaking from the heater when the door is opened as a full fire is burning. This is especially true if the chimney is on the outside wall of the house.

If the door must be opened while the fire is flaming, fully open air control for a few minutes then open the door slowly.

3.5 Rekindling a Fire

When the temperature of the room is lower and all that remains is embers, it is time to reload. Remove excess ash from the front of the firebox and bring the ashes forward. Place a new load of wood on, and at the back of the embers. Open the air control completely and close the door.

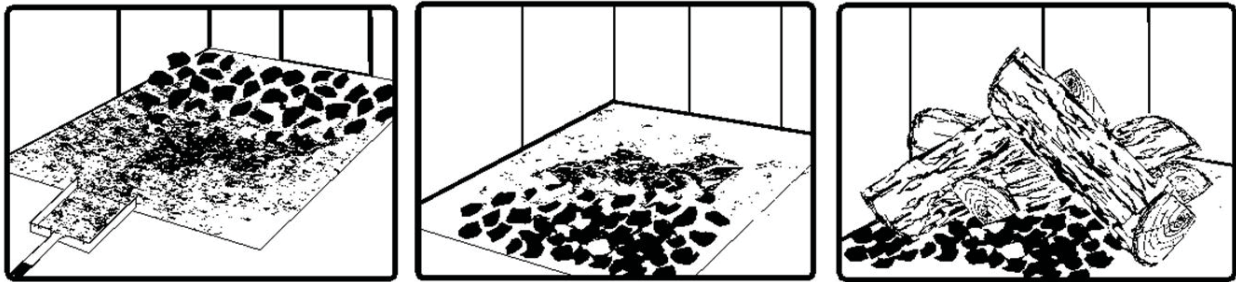

Raking the coals is useful for two reasons. First, it brings them near where most of the combustion air enters the firebox. This will ignite the new load quickly. Secondly, the charcoal will not be smothered by the new load of wood. When the embers are simply spread inside the combustion chamber, the new load smoulders for a long time before igniting.

Close the air control only when the firebox is full of bright turbulent flames, the wood is charred, and its edges are glowing.

The heater should not be left unattended during ignition and the fire should not burn at full intensity for more than a few minutes.

When lighting a new load, the appliance produces a heat surge. This heat surge is pleasant when the room temperature is cool but can be unpleasant when the room is already warm. Therefore, it is best to let each load of wood burn completely so that the room cools down before putting a load of wood back on.

Do not overfire the unit. The signs of an overfired unit are a roaring fire, the chimney connector is glowing red and an extreme heat coming from the cookstove. If this occurs, **DO NOT OPEN THE DOOR**. Shut-off the air inlet opening completely and wait until the glow has completely subsided.

3.6 Removing Ashes

Ash should be removed from the firebox every two to three days of full time heating. Ash should not accumulate excessively in the firebox since it will affect the proper operation of the appliance. The best time to remove ash is in the morning, after an overnight fire when the heater is relatively cold, but there is still a little chimney draft to draw the ash dust into the heater and prevent going out into the room.

Ashes almost always contain live embers that can stay hot for days and which release carbon monoxide gas. Ashes should be placed in a tightly covered metal container. The container must be placed on a non-combustible floor or on the ground well away from all combustible materials.

If the ashes are disposed of by burial in soil or otherwise locally dispersed, they should be kept in a closed metal container until they are completely cooled. No other waste should be placed in this container.



NEVER STORE ASHES INDOORS OR IN A NON-METALLIC CONTAINER OR ON A WOODEN DECK.

3.7 Air Intake Control

Once the firewood, firebox and chimney are hot, air intake can be reduced to achieve a steady burn.

As the air intake is reduced, the burn rate decreases. This has the effect of distributing the thermal energy of the fuel over a longer period of time. In addition, the flow rate of exhaust through the appliance and flue pipe slows down, which increases the duration of the energy transfer of the exhaust gases. As the air intake is reduced, the flame slows down.

If the flames diminish to the point of disappearing, the air intake has been reduced too early in the combustion cycle or the wood used is too wet. If the wood is dry and the air control is used properly, the flames should decrease, but remain bright and stable.

On the other hand, too much air can make the fire uncontrollable, creating very high temperatures in the unit as well as in the chimney and seriously damaging them. A reddish glow on the unit and on the chimney components indicates overheating. Excessive temperatures can cause a chimney fire.

The images shown are for guidance only and may differ from your product, but the operation remains the same. See the [EPA Loading Section](#) of the [Wood Stove Installation and Operation Manual](#) for a specific overview of the air control of your appliance.

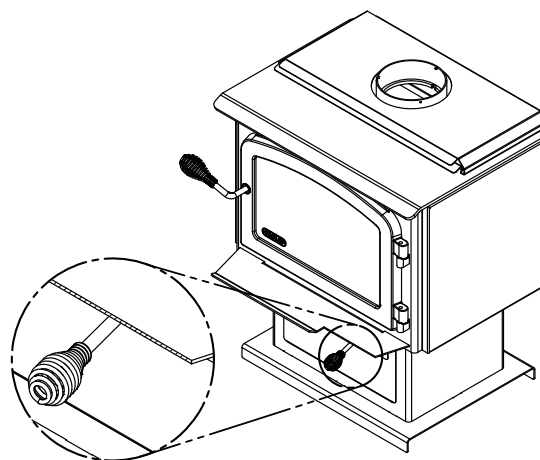

ENGLISH

3.8 Fire Types

Using the air intake control is not the only way to match the appliance heat output to the desired temperature in the house. A house will need far less heating in October than in January to maintain a comfortable temperature. Filling the firebox full in fall weather will overheat the space. Otherwise, the combustion rate will have to be reduced to a minimum and the fire will be smoky and inefficient. Here are some suggestions for building fires suitable for different heating needs. The method used to certify your appliance according to EPA Standards is presented in the [EPA Loading Section](#) of the *Wood Stove Installation and Operation Manual* of your appliance.

3.8.1 Flash Fire

To build a small fire that will produce a low heat output, use small pieces of firewood and load them crisscross in the firebox. The pieces should only be 3» to 4» in diameter. After raking the coals, lay two pieces parallel to each other diagonally in the firebox and lay two more across them in the other direction. Open the air control fully and only reduce the air after the wood is fully flaming. This kind of fire is good for mild weather and should provide enough heat for up to four hours. Small fires like this are a good time to use softer wood species and avoid overheating the house.

3.8.2 Long Lasting Fire

For a fire that will last up to eight hours but will not produce intense heat, use soft wood and place the logs compactly in the firebox. Before reducing the air intake, the load will have to burn at full heat for long enough for charring the surface of the logs. The flame must be bright before letting the fire burn by itself.

3.8.3 High Output Fires

When heating needs are high during cold weather, the fire should burn steadily and brightly. This is the time to use larger pieces of hardwood. Place the biggest pieces at the back of the firebox and place the rest of the pieces compactly. A densely built fire like this will produce the longest combustion this stove is capable of.

Special attention must be paid when building fires like this since if the air intake is reduced too quickly, the fire could smoulder. The wood must be flaming brightly before leaving the fire to burn.

3.8.4 Burn Cycle Time

The burn cycle time is the period between loading wood on a coal bed and the consumption of that wood back to a coal bed of the same size. The flaming phase of the fire lasts for roughly the first half of the burn cycle and the second half is the coal bed phase during which there is little or no flame. The burning time expected from this stove, including both phases, will vary depending on a number of things, such as:

- firebox size,
- the amount of wood loaded,
- the species of wood,
- the wood moisture content,
- the size of the space to be heated,
- the climate zone where the house is, and
- the time of the year.

The table below gives an approximate maximum burn cycle time, based on firebox volume.

Table 1 : Approximate Maximum Burn Cycle Time

FIREBOX VOLUME	MAXIMUM BURN CYCLE TIME
<1.5 cubic feet	3 to 5 hours
1.5 c.f. to 2.0 c.f.	5 to 6 hours
2.0 c.f. to 2.5 c.f.	6 to 8 hours
2.5 c.f. to 3.0 c.f.	8 to 9 hours
>3.0 c.f.	9 to 10 hours

A longer burning time is not necessarily an indication of efficient operation. It is preferable to build a smaller fire that will provide three or four hours of heating than to fully load the firebox for a much longer burn. Shorter burn cycles make it easier to match the heat output of the stove to heat demand for the space.

3.8.5 Logs Orientation

In a relatively square firebox, the wood can be loaded north-south (ends of the logs visible) or east-west (sides of the logs visible).

North-south loads allow more wood to be loaded at the same time. On the other hand, they break into smaller pieces faster. North-south loading is good for high output, long lasting fires for cold weather.

East-west loads allow a limited amount of wood since too many logs could cause them to fall on the glass. East-west loads, placed in a compact way, take a long time before breaking down. They are excellent for low-intensity, long-lasting fires in relatively mild weather.

3.8.6 Carbon Monoxide

Carbon monoxide is an odourless gas that is highly toxic which can cause death at high concentration in air. Installation of a carbon monoxide detector is highly recommended.

When unburned logs remain in the firebox and the flame disappears, go outside and look at the chimney exit. If there is visible smoke, it means that there is still combustible to burn but that the fire lacks air to burn properly. In this situation, the CO rate will increase so it is important to react. Open the door slightly and move the log with a poker. Turn it over and create a passage for the air below, making a trench with the coal bed. Add small pieces of wood to restart the combustion.

4. Maintenance

This heater will give many years of reliable service if used and maintained properly. Internal components of the firebox such as firebricks or refractory panels, baffle and air tubes will wear over time. Defective parts should always be replaced with original parts (see « Exploded diagram and parts list » in the *Wood Stove Installation and Operation Manual*).

To avoid premature deterioration, follow the lighting and reloading procedures in section "[3. Burning Wood Efficiently](#)" and also avoid letting the heater run with the air intake fully open for entire burn cycles.

4.1 Heater

4.1.1 Cleaning and Painting

Painted and plated surfaces can be wiped down with a soft, damp cloth. If the paint is scratched or damaged, it is possible to repaint the heater with a heat-resistant paint (see « Exploded diagram and parts list » in the *Wood Stove Installation and Operation Manual*). **Do not clean or paint the appliance when it is hot.** Before painting, the surface should be sanded lightly with sandpaper and then wiped off to remove dust. Apply two thin layers of paint.

4.2 Refractory Materials and Baffle

Inspect the firebricks or the refractory panels and the baffle for damage periodically and replace anything that is broken.

Operation of the heater with a cracked or missing baffle may cause unsafe temperatures and hazardous conditions and will void the warranty.

4.3 Glass Door

4.3.1 Cleaning

Under normal conditions, the door glass should stay relatively clear. If the firewood is dry enough and the operating instructions in this guide are followed, a whitish, dusty deposit will form on the inner surface of the glass after a week or so of use. This is normal and can be easily removed when the heater is cold by wiping with a damp cloth or paper towel and then drying.

When the stove runs at a low combustion rate, light brown stains may form, especially in the lower corners of the glass. This indicates that the fire has been smoky and some of the smoke has condensed on the glass. It also indicates incomplete combustion of the wood, which also means more smoke emissions and faster formation of creosote in the chimney.

The deposits that form on the glass are the best indication of the fuel quality and success in properly using the stove. These stains can be cleaned with a special wood stove glass cleaner. **Do not use abrasive products to clean the glass.**

The goal should be having a clear glass with no brown stains. If brown stains appear regularly on the glass, something about the fuel or the operating procedure needs to be changed. When brown streaks are coming from the edge of the glass, it is time to replace the gasket around the glass.

The glass gasket should be self-adhesive. Always replace the gasket with a genuine one.

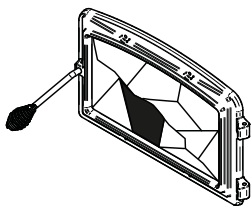

Do not clean the glass when the stove is hot.

Do not abuse the glass door by striking or slamming shut.

Do not use the stove if the glass is broken.

4.3.2 Replacement

In case of breakage or change of wearing parts, refer to the *Wood Stove Installation and Operation Manual*.

5. Operating the Stove

This wood heater has a manufacturer-set minimum low burn rate that must not be altered. It is against federal regulations to alter this setting or otherwise operate this wood heater in a manner inconsistent with operating instructions in this guide.

- Before using the stove, a pedestal base or leg kit must be installed under the product, if this is not already the case. Refer to the *Wood Stove Installation and Operation Manual*.
- The installation of the options is optional, see the *Wood Stove Installation and Operation Manual* for the available options and their installation.

5.1 Blower Operation

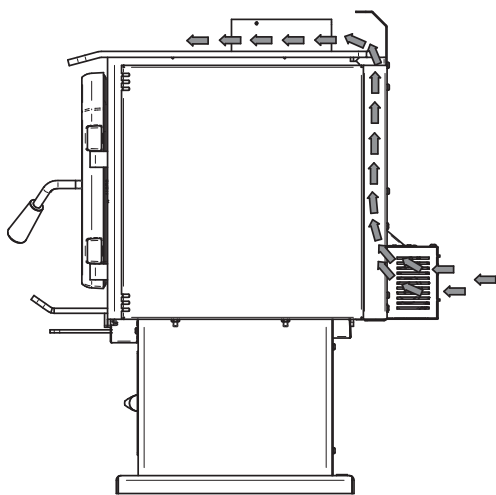

Figure 1: Air flow with a blower

It is possible, on wood stoves, to install a fan (depending on your product, it could be included or sold separately). See the Exploded View and Parts List in the *Wood Stove Installation and Operation Manual* for the original part number.

The blower is installed on the back of the stove to increase the airflow through the heat exchanger and improve hot air circulation in the room. When used regularly, the blower can provide a small increase in efficiency, up to 2%. However, the use of a blower should not be used as a way to gain more output from a stove that is undersized for the space it is intended to heat.



Ensure the blower cord is not in contact with any surface of the stove to prevent electrical shock or fire damage. Do not run cord beneath the stove.

The blower has a rheostat that can be adjusted in three different positions; either from high (HI) to low (LO) or closed (OFF).

Allow the stove to reach operating temperature (approximately one hour) before turning on the blower, since increased airflow from the blower will remove heat and affect the start up combustion efficiency.

It is possible to add a heat sensor, sold separately, to the blower. When the blower is ON, the blower will start automatically when the stove is hot enough and it will stop when the stove has cooled down. Therefore, you can leave the blower speed control at the desired setting.

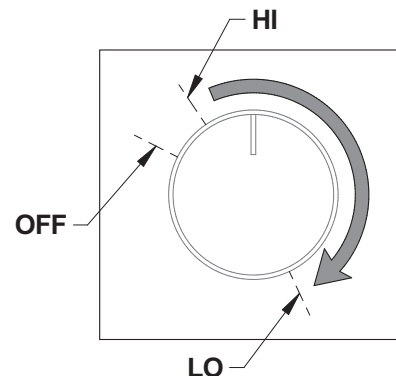

Figure 2: Blower operation

5.2 The Use of a Fire Screen

Some stoves have been tested for use with an open door in conjunction with a fire screen (**In the United States or in provinces with a particulate matter emission rate limit (e.g. US EPA), the use of wood stoves with door open with a fire screen is prohibited**), this option is sold separately (to confirm that your product has been tested with it, please refer to the Wood Stove Installation and Operation Manual). If applicable on your model, the fire screen must be properly secured on the stove to avoid any risk of sparks damaging the flooring. When the fire screen is in use, do not leave the stove unattended to respond promptly in the event of smoke spillage into the room. Potential causes of smoke spillage are described in Section "The venting system" of this guide. See "Optional Fire Screen Installation" in the *Wood Stove Installation and Operation Manual* for specifications about installation instructions.

OPERATING THE STOVE WITH A FIRE SCREEN INCREASES POSSIBILITIES OF GENERATING CARBON MONOXIDE. CARBON MONOXIDE IS AN ODOURLESS GAS THAT IS HIGHLY TOXIC WHICH CAN CAUSE DEATH AT HIGH CONCENTRATION IN AIR.

5.3 Exhaust System

Wood smoke can condense inside the chimney, forming a flammable deposit called creosote. If creosote builds up in the system, it can ignite when a hot fire is burned in the stove. A very hot fire can progress to the top of the chimney. Severe chimney fires can damage even the best chimneys. Smouldering, smoky fires can quickly cause a thick layer of creosote to form. When the stove is operated properly, the exhaust from the chimney is mostly clear and creosote builds up more slowly.

«Creosote - Formation and Need to Removal

When wood is burned slowly, it produces tar and other organic vapors, which combine with expelled moisture to form creosote. The creosote vapors condense in the relatively cooler chimney flue of a slow-burning fire. As a result, creosote residue accumulates on the flue lining. When ignited this creosote makes an extremely hot fire.

The chimney connector and chimney should be inspected at least once every two months during the heating season to determine if a creosote buildup has occurred.

The presence in a chimney of soot or creosote in excess of 1/8" (3 mm) thick will indicate

the need for immediate cleaning, possible modification of burning procedures, and more frequent inspections. If creosote has accumulated it should be removed to reduce the risk of a chimney fire.»

5.3.1 Cleaning Frequency

It is not possible to predict how much or how quickly creosote will form in the chimney. It is important, therefore, to check the build-up in the chimney monthly until the rate of creosote formation is determined. Even if creosote forms slowly in the system, the chimney should be cleaned and inspected at least once each year.

Establish a routine for the fuel, wood stove and firing technique. Check daily for creosote build-up until experience shows how often you need to clean to be safe. Be aware that the hotter the fire the less creosote is deposited, and weekly cleaning may be necessary in mild weather even though monthly cleaning may be enough in the coldest months.

Contact your local municipal or provincial fire authority for information on how to handle a chimney fire. Have a clearly understood plan to handle a chimney fire.

5.3.2 Sweeping the Chimney

Chimney sweeping can be a difficult and dangerous job. People with no chimney sweeping experience will often prefer to hire a professional chimney sweep to inspect and clean the system for the first time. After seeing the cleaning process, some will choose to do it themselves.

The chimney should be checked regularly for creosote build-up. Inspection and cleaning of the chimney can be facilitated by removing the baffle. See "Air Tubes and Baffle Installation" in the *Wood Stove Installation and Operation Manual* for more details.

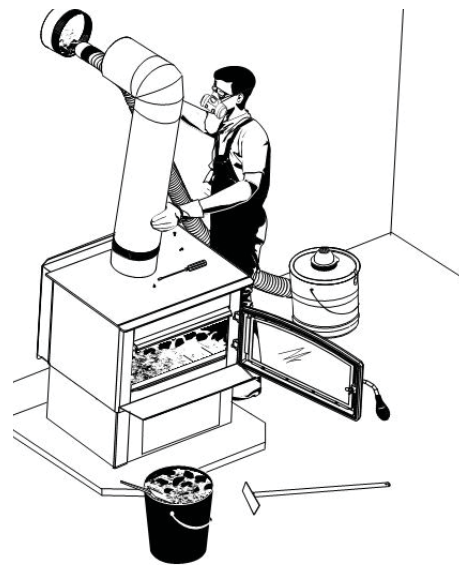

5.3.3 Chimney Fire

Regular chimney maintenance and inspection can prevent chimney fires. If you have a chimney fire, follow these steps:

1. Close the stove door and the air intake control;
2. Alert the occupants of the house of the possible danger;
3. If you require assistance, alert the fire department;
4. If possible, use a dry chemical fire extinguisher, baking soda or sand to control the fire. Do not use water as it may cause a dangerous steam explosion;

Do not use the appliance again until the stove and its chimney have been inspected by a qualified chimney sweep or a fire department inspector.

6. The Venting System

6.1 General

The venting system, made of the chimney and the connecting pipe between the stove and the chimney, acts as the engine that drives the wood heating system. Even the best stove will not function safely and efficiently if it is not connected to a suitable chimney.

The heat in the flue gases that pass from the stove and chimney connector into the chimney is not waste heat. This heat is what the chimney uses to make the draft that draws in combustion air, keeps smoke inside the stove and safely vents exhaust to outside. The heat in the flue gas can be seen as the fuel the chimney uses to create draft.

6.2 Suitable Chimneys

This stove will provide optimum efficiency and performance when connected to a 6" diameter chimney flue system. The connection to a chimney having a diameter of at least 5" (Canada only) or no more than 7" is permitted, if it allows the proper venting of combustion gases and that such application is verified and authorized by a qualified installer. Otherwise, the diameter of the flue should be 6".

To be suitable, a factory-built metal chimney must comply with UL 103 HT (U.S.A.) or ULC S629 (Canada).

6.3 Factory-Built Metal Chimneys

These are sometimes referred to as 'high temp' chimneys because they have the specific characteristics to withstand temperatures that can be created by wood burning stoves. Factory-built chimneys are tested as a system with all the necessary components for installation. The instructions provided with the chimney by its manufacturer are the only reliable source of installation guidelines. To be safe and effective, the chimney must be installed exactly in accordance with the manufacturer's instructions. Only components intended for the brand and model of chimney should be used. Never fabricate or substitute parts from other chimney brands. The chimney must be a type suitable for solid fuel.

To maintain an effective vapour barrier, insulation and waterproof at the chimney and outside flue pipe, a roof flashing must be installed and sealed with silicone adhesive.

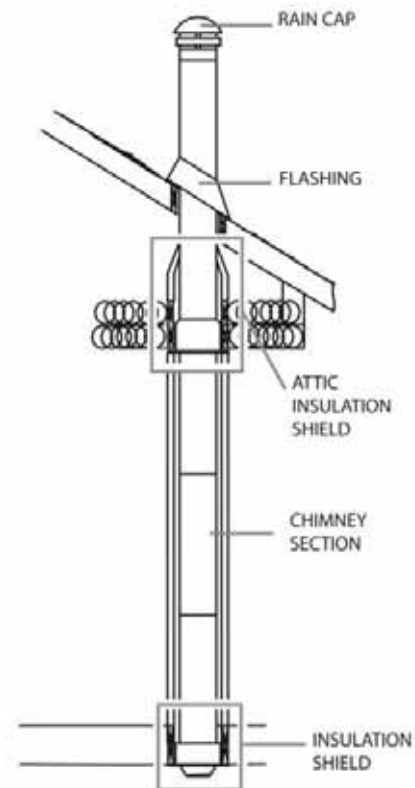

6.3.1 Factory-Built Metal Chimneys in Mobile Homes

For use in a mobile home (if allowed), this stove is to be connected to a 6" double wall factory built chimney pipe conforming to ULC-S629 or UL 103HT standards for 650°C Factory-built chimney. The total length of the flue system should be at least 12 feet including elbows, from the top of the stove.

To maintain an effective vapour barrier, insulation and waterproof at the chimney and outside flue pipe, a roof flashing must be installed and sealed with silicone adhesive.

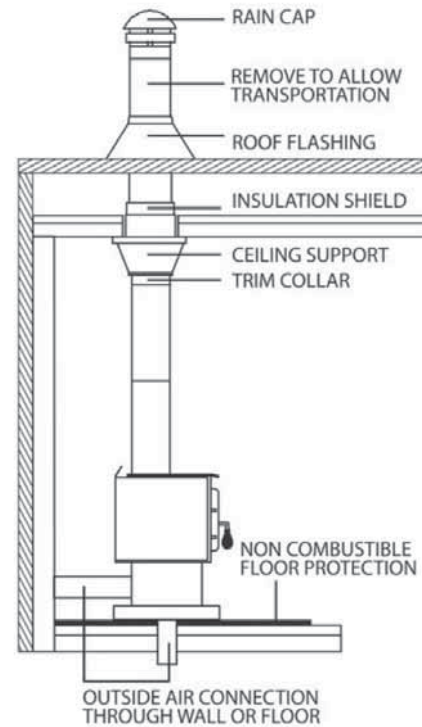

6.3.2 Masonry Chimneys

The stove may also be connected to a masonry chimney, provided the chimney complies with the construction rules found in the building code enforced locally. The chimney must have either a clay liner or a suitably listed stainless steel liner. If the masonry chimney has a square or rectangular liner that is larger in cross-sectional area than a round 6" flue, it should be relined with a suitably listed 6" stainless steel liner. Do not downsize the flue to less than 6" unless the venting system is straight and exceeds 25 feet in height. When passing through a combustible wall, the use of an insulated listed thimble is required.

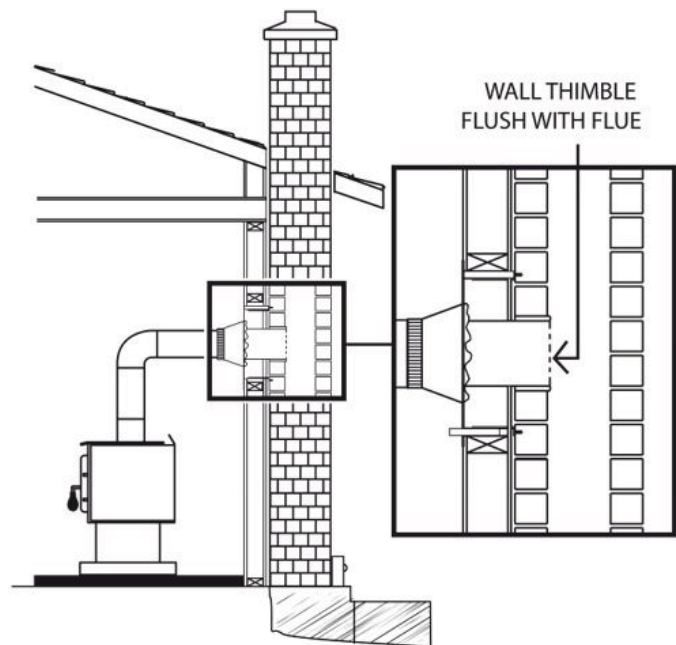

ENGLISH

6.4 Minimum Chimney Height

The top of the chimney should be tall enough to be above the air turbulence caused when wind blows against the house and its roof. The chimney must extend at least 3 ft. (1 m) above the highest point of contact with the roof, and at least 2 ft. (60 cm) higher than any roof line or obstacle within a horizontal distance of 10 ft. (3 m).

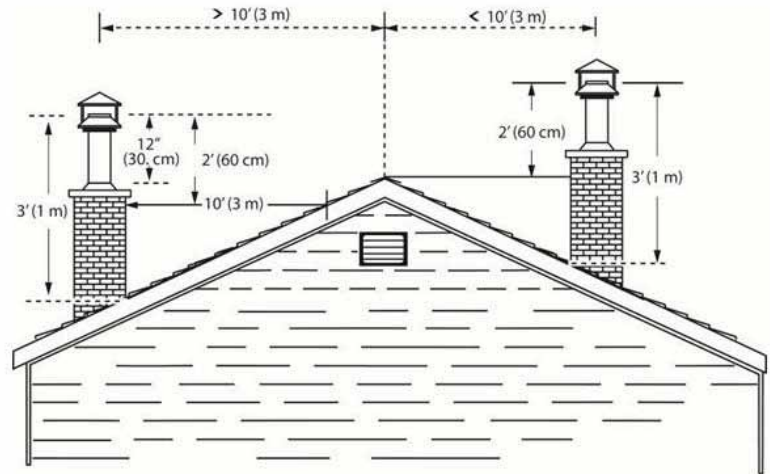

6.5 Chimney Location

Because the venting system is the engine that drives the wood heating system, it must have the right characteristics. The signs of bad system design are cold back drafting when there is no fire in the stove, slow kindling of new fires, and smoke roll-out when the door is opened for loading. There are two guidelines to follow. First, the chimney should be installed up through the heated space of the house, not out and up an outside wall. Second, the chimney should penetrate to the top of the building at or near the highest heated space.

Venting systems that rise straight up from the stove flue collar provide the best performance. Chimneys that rise inside the warm space of the house tend to provide a small amount of draft even when there is no fire burning. This means that when a fire is lit, the smoke goes up the chimney and strong draft build quickly as the chimney flue warms up. Although they are common in North America, chimneys that exit a house wall and run up outside can cause problems.

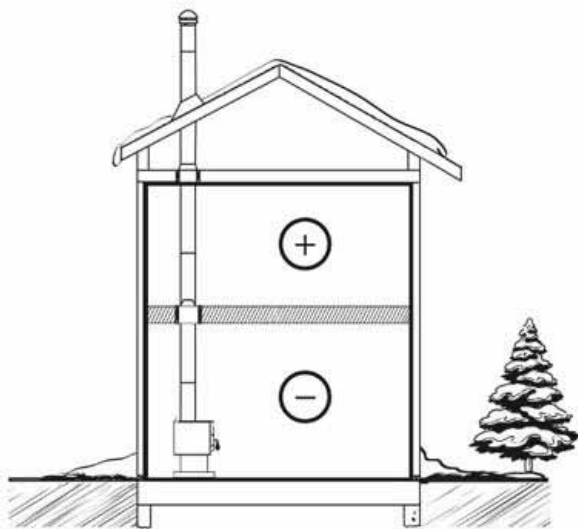

Figure 3: Good System Design

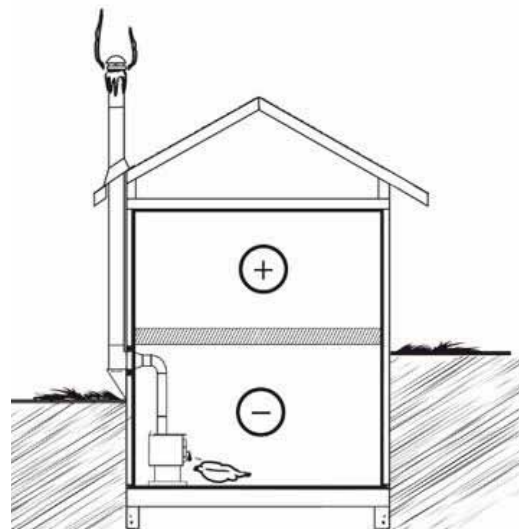

Figure 4: Inferior System Design

When it is cold outside, the warm air in the house is buoyant so it tends to rise. This creates a slight pressure difference in the house. Called 'stack effect', it produces a slightly negative pressure in the lower part of the house (compared to the outside) and a slightly positive pressure zone in the high part of the house. If there is no fire burning in a heater connected to a chimney that is shorter than the warm space inside the house, the slight negative pressure in the lower part of the house will compete against the desired upward flow in the chimney. This occurs for the two following reasons:

First, the chimney runs up the outside of the house, so the air in it is colder and denser than the warm air in the house. And second, the chimney is shorter than the heated space of the house, meaning the negative pressure in the lower part of the house will draw cold air down the chimney, through the stove and into the room. Even the finest stove will not work well when connected to this chimney.



6.6 Supply of Combustion Air

For the stove draft to work correctly, the room must have an outside or fresh air inlet, with a minimum of 5" diameter, from the house exterior to the room, that is at least sufficient to replenish the volume of air that comes out of the chimney flue. In well insulated houses an air inlet must be fitted through the outer wall that is not exposed to the prevailing winds, depending on the surrounding conditions of the house. If a vent is installed, it must be fitted in such a way that it cannot be blocked. A fresh air intake register with an airtight damper may be installed to help prevent any uncomfortable air draft.

When the stove and the chimney are completely cold, it may be necessary before starting up to provide an external air supply by opening a door or a window for a short period. A house constructed or renovated in a waterproof manner is prone to not having the air exchange required for the proper functioning of a wood heating appliance.

In that case, avoid, during startups, to use appliances that evacuate air outside of the house, such as:

- Cookstove hood
- Bathroom vent
- Air exchange system
- Ventilated central vacuum cleaner
- Dryer

The supply of fresh combustion air can be done in several ways, provided they comply with CSA B365 and NFPA211.

In Canada, wood stoves are not required to have a combustion air supply from outside, except for mobile homes. Research has shown that outside air supply do not compensate for the depressurization of the house and may not be sufficient to provide a supply of combustion air in windy weather. However, to reduce the risks against smoke spillage due to house depressurization,

a carbon monoxide (CO) detector is required in the room where the stove is installed. The CO detector will provide warning if for any reason the wood stove fails to function correctly.

6.6.1 Mobile Home

If your stove is 'mobile home approved', It must have a supply of combustion air from outdoors. The air intake must not draw air from the attic, from the basement, from a garage or any enclosed space. Air must be drawn from a ventilated crawl space under the floor or directly from outside. Install a flexible or rigid, insulated pipe (HVAC type, must comply to ULC S110 and/or UL 181, Class 0 or Class 1) to the fresh air intake.

Where a mobile home has been converted to a standard house by mounting it on a permanent basement foundation, the supply of outdoor air is not required.

It is prohibited to use this wood stove with a fire screen in a mobile home.

6.6.2 Conventional House

The safest and most reliable supply of combustion air for a wood stove is from the room in which it is installed. Room air is already preheated so it will not chill the fire, and its availability is not affected by wind pressures on the house. Contrary to commonly expressed concerns, almost all tightly sealed new houses have enough natural leakage to provide the small amount of air needed by the stove. The only case in which the wood stove may not have adequate access to combustion air is if the operation of a powerful exhaust device (such as a kitchen range exhaust) causes the pressure in the house to become negative relative to outdoors.

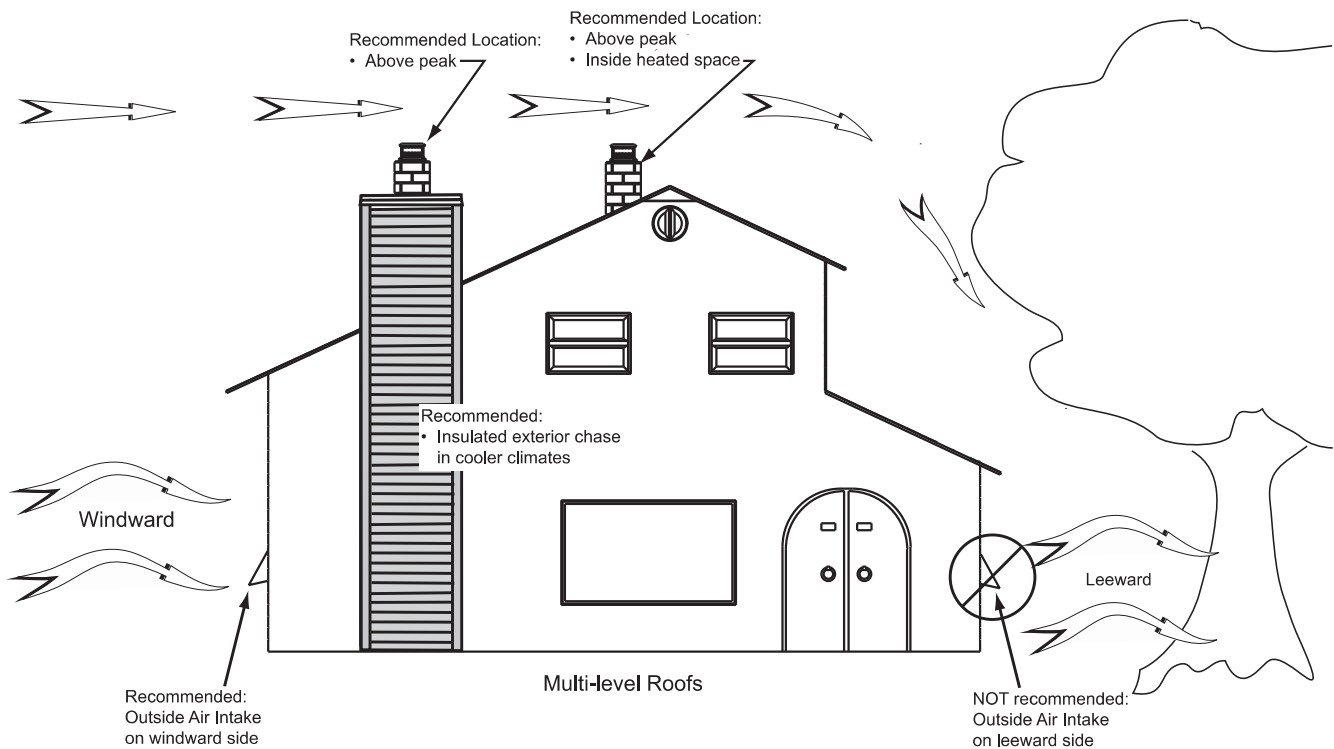

Figure 5: Air supply in conventional houses

If an air intake is installed through the wall of the house, its pressure can vary during windy weather. If there are changes in wood stove performance in windy weather, and in particular if smoke puffs from the stove, the air duct should be disconnected from the stove to determine if it is the cause of the problem. In some windy conditions, negative pressure at the duct weather

hood outside the house wall may draw hot exhaust gases from the stove backwards through the duct to outdoors. Check the outdoor air duct for soot deposits when the full system is cleaned and inspected at least once each year.

To reduce the risks against smoke spillage due to house depressurization, a carbon monoxide (CO) and a smoke detector is required in the room where the stove is installed. The CO detector will provide warning if for any reason the wood stove fails to function correctly.

6.7 Installing the Chimney Connector

The chimney connector is the single or double wall pipe installed between the stove flue collar and the chimney breech. Single wall pipe components are available from most hardware and building supply stores. These components are not usually tested to a particular standard and certified as compliant. Therefore, a list of rules found in solid fuel installation codes apply to the installation of a single wall pipe.

Double wall chimney connectors are tested and certified. The rules for double wall pipe are found in the manufacturer's installation instructions. These rules will be very different than those for single wall.

6.7.1 Installation of Single Wall Chimney Connector

The chimney connector assembly has been called 'the weak link' in the safety of wood heating systems because failure to install the connector properly (which has been common in the past) can result in house fires.

The best flue pipe assembly is one that rises straight up from the stove to the base of the chimney with no elbows. Straight assemblies are less likely to cause problems like smoke roll-out when the door is opened for loading. They are also more stable and easier to maintain than assemblies with elbows. Horizontal runs of flue pipe should be avoided where possible because they reduce chimney draft.

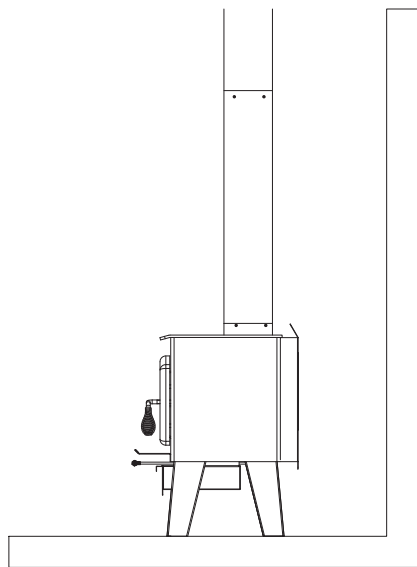

Figure 6: Best

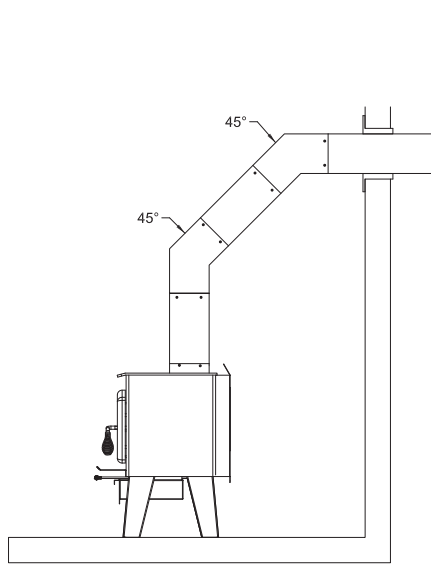

Figure 7: Acceptable

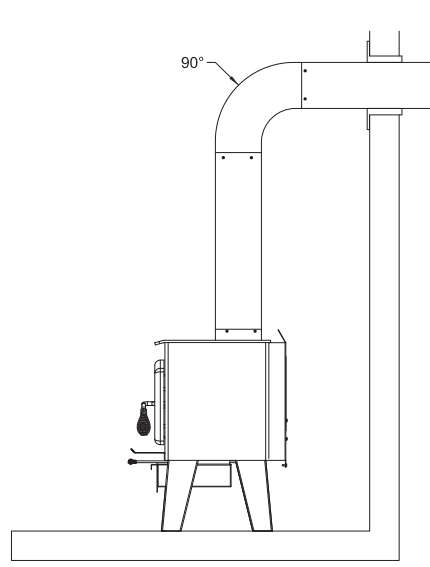

Figure 8: Avoid

The rules below are based on those found in the CSA-B365 installation code. Please carefully follow these installation instruction rules, or those enforced by the local code.

- Maximum overall length of horizontal pipe: 10 ft. (3 m) including elbows.
- Minimum clearance from combustible material: 18" (450 mm). The minimum clearance may be reduced by 50 percent to 9" (225 mm) if suitable shielding is installed either on the pipe or on the combustible surface.
- The assembly should be as short and direct as possible between the stove and chimney. The use of two 45 degree elbows is often preferable to a single 90 degree elbow because less turbulence is created in the exhaust flow and they result in less horizontal run.
- The minimum overall height of the chimney system, measured from the stove top to the exterior termination cap of the chimney should be at least 12 ft. (3.66 m). A chimney which is too short may lack the "tunnel effect" required to obtain a proper draft.
- Maximum number of 90-degree elbows: 2.
- Maximum unsupported horizontal length: 3 ft. (1 m).
- Galvanized flue pipes must not be used because the coatings vaporize at high temperatures and release dangerous gases. Use black painted flue pipes.
- Flue pipes must be at least 24 gauge in thickness.
- Flue pipe joints should overlap 1 ¼" (30 mm).
- Each joint in the assembly must be fastened with at least three screws.
- The assembly must make allowance for expansion: elbows in assemblies allow for expansion; straight assemblies should include an inspection wrap with one end unfastened, or a telescopic section.
- Minimum upward slope towards the chimney: ¼ in/ft. (20 mm/m).
- **One end of the assembly must be securely fastened to the flue collar** with 3 sheet metal screws and the other end securely fastened to the chimney.
- There must be provision for cleaning of the pipes, either through a clean out or by removal of the pipe assembly. Removal of the assembly should not require that the stove be moved.
- The male ends of the sections must be oriented towards the appliance so that falling dust and condensation stay inside the pipe.
- A flue pipe must never pass through a combustible floor or ceiling or through an attic, roof space, closet or concealed space. Where passage through a wall or partition of combustible construction is desired, the installation shall conform to CAN/CSA-B365, Installation Code for Solid-Fuel-Burning Appliances and Equipment.
- A straight up connector assembly needs either a telescopic length or an inspection wrap (pipe coupler) to allow it to be assembled and disassembled without moving the stove.
- A straight flue pipe assembly offers the least restriction to gas flow and results in a stronger draft. Straight assemblies also need less maintenance because there are no corners to collect creosote.
- The chimney and chimney connector must be clean and in good condition.

This document is available for free download on the manufacturer's website. It is a copyrighted document. Resale is strictly prohibited. The manufacturer may update this document from time to time and cannot be responsible for problems, injuries, or damages arising out of the use of information contained in any document obtained from unauthorized sources.



Stove Builder International inc.
250, rue de Copenhague,
St-Augustin-de-Desmaures (Québec) Canada
G3A 2H3
1-877-356-6663
www.sbi-international.com
tech@sbi-international.com