

ENERVEX® RSHT 009-016 CHIMNEY FAN

3932002 04.18

Product Information

Use

The RSHT Chimney Fan is a high temperature exhaust fan used to maintain proper draft in a solid fuel chimney or stack system. Typical applications include venting of:

- Fireplaces
- BBQs
- Pizza ovens
- Stoves

Description

The RSHT Fan is specifically designed for applications where efficient operation, low noise level, low energy consumption, variable speed and compact design are of utmost importance. It should be installed at the termination point of the chimney or stack section and can be mounted on masonry or metal chimneys. It is typically mounted in the vertical position, but may be sidewall vented as well.

The fan assures a negative pressure is maintained in the entire chimney or stack system. The fan discharges horizontally (vertically, if side-wall vented) at a high velocity.

The fan housing is hinged and the top can be opened for easy service and access to stack.

The RSHT is for use where flue gas temperatures do not exceed 1400°F (760°C) for intermittent operation and 1000°F (538°C) for continuous operation.

Material

Housing is made of 3/16" stainless steel. Finished with one coat of black paint for added corrosion resistance.

Axial vanes are stainless steel, dynamically and statically balanced to assure low noise level and vibration-free operation.

Motor

Split capacitor, totally enclosed. Class H insulated, IP54 Protection Class. Sealed ball bearings. Variable Speed. Thermal overload protection.



Standard Equipment

- 2"x4" or 4"x4" Junction Box with Cover and Conduit
- Fiber Mat and Mounting Brackets
- Bird Screen
- 5 Amp FSC Fan Speed Control

Optional Equipment

- ADC 100 Fan Control
- ADC 150 Modulating Control
- EFC 211 Fan Control
- PDS Proven Draft Switch
- SCA Steel Chimney Adaptor
- MFD-S Manual Fireplace Damper
- MFD Mechanical Fireplace Damper

Listings

The RSHT 009-016 Chimney Fan is ETL Listed in the U.S. and Canada under file no. 514733:

- UL 378 Standard for Draft Equipment
- CSA-CAN3-B255-M81 Standard for Mechanical Flue Gas Exhausters

Warranty

- 2-Year Factory Warranty on entire fan
- 10-Year Warranty Against Corrosion Perforation

Manufactured at ISO9001 certified plant.



Intertek
ETL File 514733

ENERVEX Inc.
1685 Bluegrass Lakes Parkway
Alpharetta, GA 30004
USA

P: 770.587.3238
F: 770.587.4731
T: 800.255.2923
info@enervex.com
www.enervex.com

ENERVEX®
VENTING DESIGN SOLUTIONS

ENERVEX® RSHT 009-016 CHIMNEY FAN

3932002 04.18

Product Information

Specifications

Model	RSHT 009	RSHT 012	RSHT 014	RSHT 016	
Discharge	Horizontal				
Fan Type	Axial Vane				
Motor Type	Totally enclosed, Variable speed, Class F				
Voltage	VAC	1x20 V @ 60 Hz			
Amperage	amps	0.65	1.33	2.70	4.40
RPM		1600		1580	
CFM	@0.0 Ps	290	550	880	1460
Motor Output	hp / kw	0.11 / 0.08	0.13 / 0.10	0.34 / 0.25	0.47 / 0.35
Weight	lbs / kg	25.6 / 11.6	33.5 / 15.2	41.9 / 19.0	47.2 / 21.4
Dimensions	A in / mm	11.7 / 298	12.8 / 325	14.6 / 372	15.7 / 400
	B x B in / mm	11.7 / 296	14.3 / 364	16.6 / 422	18.8 / 478
	C in / mm	10.8 / 275	13.5 / 344	15.6 / 395	17.4 / 441
	D in / mm	3.0 / 75	3.3 / 85	3.9 / 100	3.9 / 100
	E in / mm	8.7 / 220	11.0 / 280	13.0 / 330	15.0 / 380
Temperature Rating	Interm.	1400°F / 760°C			
	Cont.	1000°F / 538°C			

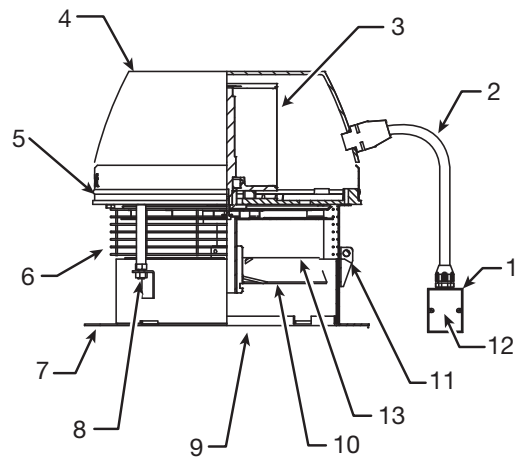
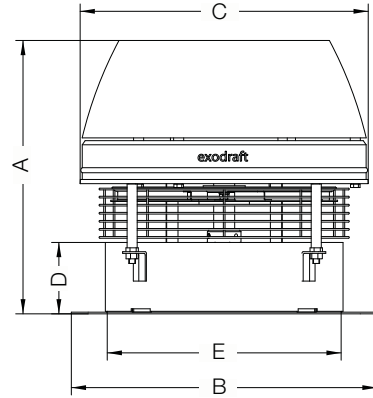

- | | |
|-----------------|------------------------------------|
| 1 Junction box | 8 Locking nut |
| 2 Conduit/cord | 9 Inlet |
| 3 Motor | 10 Axial vane |
| 4 Motor housing | 11 Hinges |
| 5 Motor plate | 12 Capacitor (inside junction box) |
| 6 Bird screen | 13 Cooling wheel |
| 7 Base plate | |

Capacity

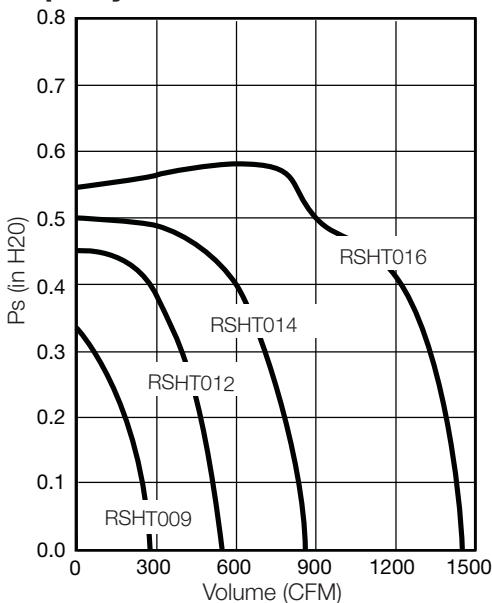

Specifications are subject to change without notice.

ENERVEX Inc.
1685 Bluegrass Lakes Parkway
Alpharetta, GA 30004
USA

P: 770.587.3238
F: 770.587.4731
T: 800.255.2923
info@enervex.com
www.enervex.com

ENERVEX®
VENTING DESIGN SOLUTIONS