

FasNSeal W2® - Double-Wall

Vent Length

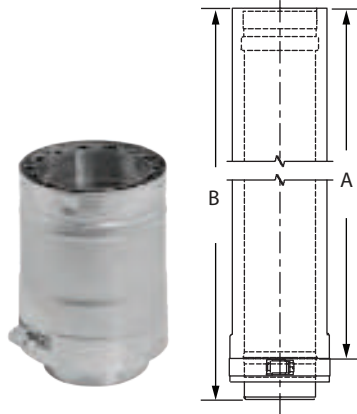

Used for venting special gas burning Categories II, III and IV appliances. To calculate O.D. add 1" to vent diameter.

Available in 316L Stainless Steel

SIZE	ORDER #	STOCK #	A	B	SIZE	ORDER #	STOCK #	A	B
3"	W2-603	810003656	4"	6"	8"	W2-2408	810003763	22"	24"
3"	W2-1203	810003657	10"	12"	8"	W2-3608	810003764	34"	36"
3"	W2-1803	810003658	16"	18"	9"	W2-609	810003783	4"	6"
3"	W2-2403	810003659	22"	24"	9"	W2-1209	810003784	10"	12"
3"	W2-3603	810003660	34"	36"	9"	W2-1809	810003785	16"	18"
4"	W2-604	810003677	4"	6"	9"	W2-2409	810003786	22"	24"
4"	W2-1204	810003678	10"	12"	9"	W2-3609	810003787	34"	36"
4"	W2-1804	810003679	16"	18"	10"	W2-610	810003803	4"	6"
4"	W2-2404	810003680	22"	24"	10"	W2-1210	810003804	10"	12"
4"	W2-3604	810003681	34"	36"	10"	W2-1810	810003805	16"	18"
5"	W2-605	810003698	4"	6"	10"	W2-2410	810003806	22"	24"
5"	W2-1205	810003699	10"	12"	10"	W2-3610	810003807	34"	36"
5"	W2-1805	810003700	16"	18"	12"	W2-612	810003828	4"	6"
5"	W2-2405	810003701	22"	24"	12"	W2-1212	810003829	10"	12"
5"	W2-3605	810003702	3"	36"	12"	W2-1812	810003830	16"	18"
6"	W2-606	810003719	4"	6"	12"	W2-2412	810003831	22"	24"
6"	W2-1206	810003720	10"	12"	12"	W2-3612	810003832	34"	36"
6"	W2-1806	810003721	16"	18"	14"	W2-614	810003853	4"	6"
6"	W2-2406	810003722	22"	24"	14"	W2-1214	810003854	10"	12"
6"	W2-3606	810003723	34"	36"	14"	W2-1814	810003855	16"	18"
7"	W2-607	810003740	4"	6"	14"	W2-2414	810003856	22"	24"
7"	W2-1207	810003741	10"	12"	14"	W2-3614	810003857	34"	36"
7"	W2-1807	810003742	16"	18"	16"	W2-616	810003876	4"	6"
7"	W2-2407	810003743	22"	24"	16"	W2-1216	810003877	10"	12"
7"	W2-3607	810003744	34"	36"	16"	W2-1816	810003878	16"	18"
8"	W2-608	810003760	4"	6"	16"	W2-2416	810003879	22"	24"
8"	W2-1208	810003761	10"	12"	16"	W2-3616	810003880	34"	36"
8"	W2-1808	810003762	16"	18"					

Adjustable Vent Length

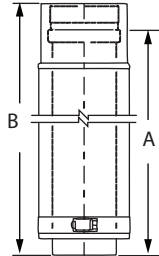

Use to add variable length to your straight length of FasNSeal pipe. Adds 2"-14" of length. Requires at least 4" overlap for a secure connection. ***Available in 316L Stainless Steel***

SIZE	ORDER #	STOCK #	A	B	SIZE	ORDER #	STOCK #	A	B
3"	W2-AVL3	810003661	2"-14"	18"	9"	W2-AVL9	810003788	2"-14"	18"
4"	W2-AVL4	810003682	2"-14"	18"	10"	W2-AVL10	810003808	2"-14"	18"
5"	W2-AVL5	810003703	2"-14"	18"	12"	W2-AVL12	810003833	2"-14"	18"
6"	W2-AVL6	810003724	2"-14"	18"	14"	W2-AVL14	810003858	2"-14"	18"
7"	W2-AVL7	810003745	2"-14"	18"	16"	W2-AVL16	810003881	2"-14"	18"
8"	W2-AVL8	810003765	2"-14"	18"					

90° Elbow

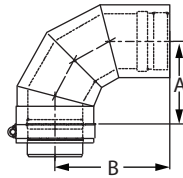

Use to go from horizontal to vertical runs or vertical to horizontal runs. Use to turn vent 90°. ***Available in 316L Stainless Steel***

SIZE	ORDER #	STOCK #	A	B	SIZE	ORDER #	STOCK #	A	B
3"	W2-9003	810003662	4"	6"	9"	W2-9009	810003789	7"	9"
4"	W2-9004	810003683	4 1/2"	6 1/4"	10"	W2-9010	810003809	7 1/2"	9 3/8"
5"	W2-9005	810003704	5"	6 3/4"	12"	W2-9012	810003834	8 1/2"	10 1/4"
6"	W2-9006	810003725	5 1/2"	7 1/2"	14"	W2-9014	810003859	9 1/2"	11 3/8"
7"	W2-9007	810003746	6 1/8"	7 7/8"	16"	W2-9016	810003882	11"	12 1/2"
8"	W2-9008	810003766	6 1/2"	8 1/4"					

88° Elbow

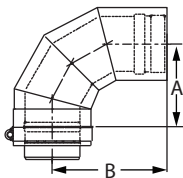

Use to transition from a vertical to a horizontal run. Facilitates a 2° pitch towards the condensate drain for good condensate management. ***Available in 316L Stainless Steel***

SIZE	ORDER #	STOCK #	A	B	SIZE	ORDER #	STOCK #	A	B
3"	W2-8803	810003663	4"	6"	12"	W2-8812	810003835	8 1/2"	10 1/4"
4"	W2-8804	810003684	4 1/2"	6 3/5"	14"	W2-8814	810003860	9 1/2"	11 3/8"
5"	W2-8805	810003705	5"	6 3/4"	16"	W2-8816	810003883	11"	12 1/2"
6"	W2-8806	810003726	5 1/2"	7 1/2"					
7"	W2-8807	810003747	6 1/8"	7 7/8"					
8"	W2-8808	810003767	6 1/2"	8 1/4"					
9"	W2-8809	810003790	7"	9"					
10"	W2-8810	810003810	7 1/2"	9 3/8"					

45° Elbow

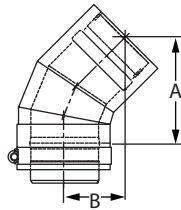

Offsets obstructions as needed. Allows for better condensate management and less back pressure.

Available in 316L Stainless Steel

SIZE	ORDER #	STOCK #	A	B	SIZE	ORDER #	STOCK #	A	B
3"	W2-4503	810003664	5 3/8"	3"	9"	W2-4509	810003791	7 1/2"	3 7/8"
4"	W2-4504	810003685	5 5/8"	3 1/8"	10"	W2-4510	810003811	7 7/8"	4"
5"	W2-4505	810003706	6"	3 1/4"	12"	W2-4512	810003836	8 1/2"	4 1/4"
6"	W2-4506	810003727	6 3/8"	3 3/8"	14"	W2-4514	810003861	9 1/4"	4 5/8"
7"	W2-4507	810003748	6 3/4"	3 1/2"	16"	W2-4516	810003884	10"	4 7/8"
8"	W2-4508	810003768	7 1/8"	3 5/8"					

30° Elbow

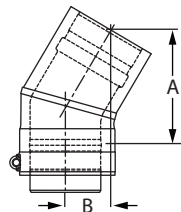

Offsets obstructions as needed. Allows for better condensate management and less back pressure.

Available in 316L Stainless Steel

SIZE	ORDER #	STOCK #	A	B	SIZE	ORDER #	STOCK #	A	B
3"	W2-3003	810003665	4 7/8"	1 7/8"	9"	W2-3009	810003792	7"	2 1/2"
4"	W2-3004	810003686	5 1/8"	1 7/8"	10"	W2-3010	810003812	6 1/2"	2 1/4"
5"	W2-3005	810003707	5 1/4"	2"	12"	W2-3012	810003837	7"	2 1/2"
6"	W2-3006	810003728	5 1/2"	2"	14"	W2-3014	810003862	7 1/2"	2 1/2"
7"	W2-3007	810003749	5 7/8"	2"	16"	W2-3016	810003885	8 1/8"	2 3/4"
8"	W2-3008	810003769	6 1/8"	2 1/8"					

15° Elbow

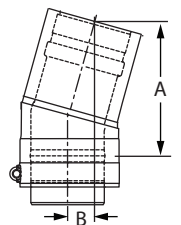

Offsets obstructions as needed. Allows for better condensate management and less back pressure.

Available in 316L Stainless Steel

SIZE	ORDER #	STOCK #	A	B	SIZE	ORDER #	STOCK #	A	B
3"	W2-1503	810003666	4 3/8"	7/8"	9"	W2-1509	810003793	5 1/4"	1"
4"	W2-1504	810003687	4 1/2"	1"	10"	W2-1510	810003813	5 1/4"	1"
5"	W2-1505	810003708	4 5/8"	7/8"	12"	W2-1512	810003838	5 1/2"	1"
6"	W2-1506	810003729	4 3/4"	7/8"	14"	W2-1514	810003863	5 3/4"	1"
7"	W2-1507	810003750	4 7/8"	1"	16"	W2-1516	810003886	6 1/8"	1"
8"	W2-1508	810003770	5 1/8"	1"					

Standard Tee

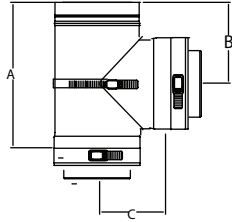

Use for a 90° offset, to combine connections from two or more appliances into a common vent or as a condensate management point when used in conjunction with drain fitting. All Standard Tees have completely welded inner walls.

Available in 316L Stainless Steel

SIZE	ORDER #	STOCK #	A	B	C	SIZE	ORDER #	STOCK #	A	B	C
3"	W2-T3	810003667	7 3/10"	4 1/2"	3"	9"	W2-T9	810003794	13 3/10"	7 3/10"	6"
4"	W2-T4	810003688	8 3/10"	4 4/5"	3 1/2"	10"	W2-T10	810003814	14 3/10"	7 4/5"	6 1/2"
5"	W2-T5	810003709	9 3/10"	5 3/10"	4"	12"	W2-T12	810003839	16 3/10"	9"	7"
6"	W2-T6	810003730	10 3/10"	5 4/5"	4 1/2"	14"	W2-T14	810003864	20 3/10"	11"	8 1/2"
7"	W2-T7	810003751	11 3/10"	6 3/10"	5"	16"	W2-T16	810003887	22 3/10"	12"	9 1/2"
8"	W2-T8	810003771	12 3/10"	6 4/5"	5 1/2"						

Wide Mouth Boot Tee

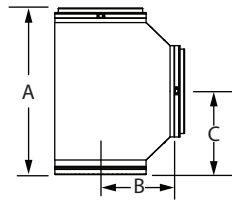

Use to transition from horizontal to vertical with improved flue gas flow with angled gradual transitions. Can also be used as a manifold connection to gang boilers into a common vent. Completely welded inner walls.

Available in 316L Stainless Steel

SIZE	ORDER #	STOCK #	A	B	C	SIZE	ORDER #	STOCK #	A	B	C
4"	W2-WBT4	810003689	15 3/4"	7"	6 9/10"	9"	W2-WBT9	810003795	20 3/4"	9 1/2"	9 4/10"
5"	W2-WBT5	810003710	16 3/4"	7 1/2"	7 4/10"	10"	W2-WBT10	810003815	21 3/4"	10"	9 9/10"
6"	W2-WBT6	810003731	17 3/4"	8"	7 9/10"	12"	W2-WBT12	810003840	23 3/4"	11"	10 10/10"
7"	W2-WBT7	810003752	18 3/4"	8 1/2"	8 4/10"	14"	W2-WBT14	810003865	25 3/4"	12"	11 11/10"
8"	W2-WBT8	810003772	19 3/4"	9"	8 9/10"	16"	W2-WBT16	810003888	27 3/4"	13"	12 12/10"

Double-Wall Wye



6" - 10" Diameters

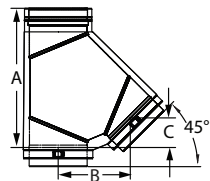

12" - 16" Diameters

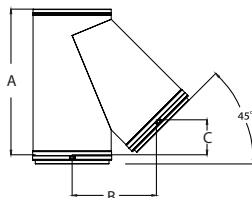

Use in place of any DuraVent tee for a 45° angle instead of 90°; can be used as a manifold connection to gang multiple boilers into a common vent.

SIZE	ORDER #	STOCK #	A	B	C
6"	W2-WYE06	810004863	14 1/2"	7 1/2"	3 1/8"
7"	W2-WYE07	810007021	16 1/3"	8 3/5"	3 1/2"
8"	W2-WYE08	810004864	18"	9 7/10"	4"
9"	W2-WYE09	810007022	19 7/10"	10 7/10"	4 2/5"
10"	W2-WYE10	810004865	21 2/5"	11 13/16"	4 15/16"
12"	W2-WYE12	810004866	24 15/16"	14"	5 13/16"
14"	W2-WYE14	810004867	28 3/10"	16 1/8"	6 3/5"
16"	W2-WYE16	810009327	31 13/16"	18 1/5"	7 1/2"

Double-Wall In creaser Wye



6" - 10" Diameters

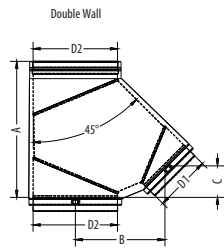

12" - 16" Diameters

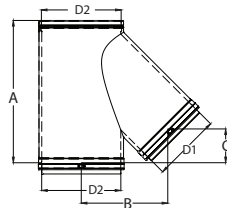

Use in place of any tee for a 45° angle instead of 90°. The branch has a smaller diameter, so it can be used to increase to a larger diameter as a manifold connection to gang multiple boilers into a common vent. Maximum diameter increase is 6". Available in custom size combinations.

SIZE	ORDER #	STOCK #	A	B	C
6" x 8"	W2-WYE0608	810012570	15 3/8"	9 1/4"	3 3/8"
6" x 10"	W2-WYE0610	810012571	16"	10 5/8"	3 5/8"
6" x 12"	W2-WYE0612	810012572	17 1/8"	12 1/2"	4"
8" x 10"	W2-WYE0810	810012573	18 3/4"	11 3/8"	4 3/8"
8" x 12"	W2-WYE0812	810012574	19 3/8"	12 3/4"	4 1/2"
8" x 14"	W2-WYE0814	810012575	20"	14 1/4"	4 5/8"
10" x 12"	W2-WYE1012	810012576	22 1/4"	13 1/2"	5 1/2"
10" x 14"	W2-WYE1014	810012577	22 7/8"	15"	5 3/8"
10" x 16"	W2-WYE1016	810012578	23 1/2"	16 3/8"	5 1/2"
12" x 14"	W2-WYE1214	810012579	25 5/8"	15 5/8"	6 1/8"

Tee Cap

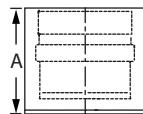

Use to cap Standard Tee, Branch Tee or Boot Tee. Remove Tee Cap to inspect the system; clean out debris.

Available in 316L Stainless Steel

SIZE	ORDER #	STOCK #	A	SIZE	ORDER #	STOCK #	A
3"	W2-TC3	810003668	3 1/2"	9"	W2-TC9	810003796	3 1/2"
4"	W2-TC4	810003690	3 1/2"	10"	W2-TC10	810003817	3 1/2"
5"	W2-TC5	810003711	3 1/2"	12"	W2-TC12	810003841	3 1/2"
6"	W2-TC6	810003732	3 1/2"	14"	W2-TC14	810003866	3 1/2"
7"	W2-TC7	810003753	3 1/2"	16"	W2-TC16	810003889	3 1/2"
8"	W2-TC8	810003774	3 1/2"				

Drain Fitting

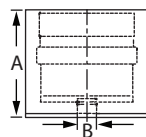

Use instead of Tee Cap to manage condensates at the bottom of a vertical run. For vent systems larger than 5", use an IPS Drain Fitting. ***Available in 316L Stainless Steel***

SIZE	ORDER #	STOCK #	A	B
3"	W2-DF3	810003670	3 1/2"	5/8"
4"	W2-DF4	810003692	3 1/2"	5/8"
5"	W2-DF5	810003713	3 1/2"	5/8"

IPS Drain Fitting

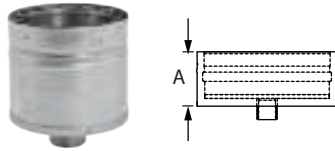

Use to connect iron drain pipe to flow acidic condensates to a neutralization tank before disposal. Uses 1" NPT thread.

Available in 316L Stainless Steel

SIZE	ORDER #	STOCK #	A	SIZE	ORDER #	STOCK #	A
3"	W2-IPSDF03	810003671	3 1/2"	9"	W2-IPSDF09	810003798	3 1/2"
4"	W2-IPSDF04	810003693	3 1/2"	10"	W2-IPSDF10	810003818	3 1/2"
5"	W2-IPSDF05	810003714	3 1/2"	12"	W2-IPSDF12	810003843	3 1/2"
6"	W2-IPSDF06	810003734	3 1/2"	14"	W2-IPSDF14	810003868	3 1/2"
7"	W2-IPSDF07	810003755	3 1/2"	16"	W2-IPSDF16	810003890	3 1/2"
8"	W2-IPSDF08	810003775	3 1/2"				

Wall Thimble w/ AVL

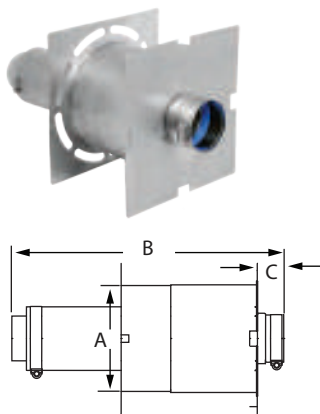

Use for through-the-wall termination. Fits between standard wall studs. 3"-5" diameters accommodates wall thickness of 4 1/4" to 8 1/2". 6"-16" diameters accommodate wall thickness of 5 3/4" to 11 1/2". AVL pipe allows for adjustability in length variance.

Available in 316L Stainless Steel

SIZE	ORDER #	STOCK #	A	B	C
3"	W2-WT3	810003672	6"	18"	1 4/5"
4"	W2-WT4	810003694	7"	18"	1 4/5"
5"	W2-WT5	810003715	8"	18"	1 4/5"
6"	W2-WT6	810003735	9"	18"	1 4/5"
7"	W2-WT7	810003756	10"	18"	1 4/5"
8"	W2-WT8	810003776	11"	18"	1 4/5"
9"	W2-WT9	810003799	12"	18"	1 4/5"
10"	W2-WT10	810003819	13"	18"	1 4/5"
12"	W2-WT12	810003844	15"	18"	1 4/5"
14"	W2-WT14	810003869	17"	18"	1 4/5"
16"	W2-WT16	810003892	19"	18"	1 4/5"

Wall Thimble Sleeve

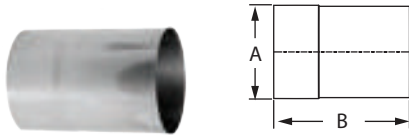

When installing FasNSeal W2 with this component use 1" larger diameter, (e.g. 10" vent system, use 11" size).

SIZE	ORDER #	STOCK #	A	B
3"	FSWTE3	810003126	6"	9"
4"	FSWTE4	810003180	7"	9"
5"	FSWTE5	810003233	8"	9"
6"	FSWTE6	810003286	9"	9"
7"	FSWTE7	810003330	10"	9"
8"	FSWTE8	810003373	11"	9"
9"	FSWTE9	810003412	12"	9"
10"	FSWTE10	810003450	13"	9"
12"	FSWTE12	810003491	15"	9"
14"	FSWTE14	810003531	17"	9"
16"	FSWTE16	810003566	19"	9"

Support Clamp

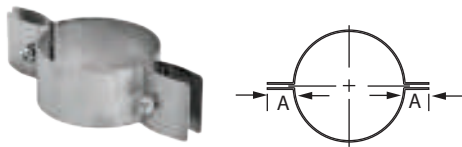

Use to support vertical and horizontal runs. Recommended every 10' in the vertical run. Use additional Support Clamps as needed. When installing FasNSeal W2 with this component use 1" larger diameter, (e.g. 10" vent system, use 11" size).

SIZE	ORDER #	STOCK #	A	SIZE	ORDER #	STOCK #	A
4"	FSCL4	810003182	1 1/2"	10"	FSCL10	810003452	1 1/2"
5"	FSCL5	810003235	1 1/2"	11"	FSCL11	810003825	1 1/2"
6"	FSCL6	810003288	1 1/2"	13"	FSCL13	810003849	1 1/2"
7"	FSCL7	810003332	1 1/2"	15"	FSCL15	810003873	1 1/2"
8"	FSCL8	810003375	1 1/2"				
9"	FSCL9	810003414	1 1/2"				

Rain Cap

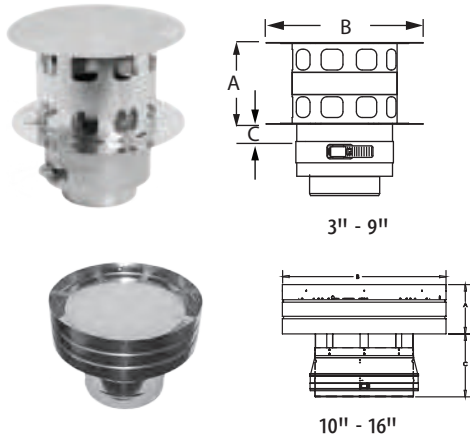

Use where pipe terminates above the roof line. When terminating larger than 12" vent diameter use a Termination Cone.

SIZE	ORDER #	STOCK #	A	B	C
3"	W2-RC3	810003673	3 1/2"	6 4/5"	1"
4"	W2-RC4	810003695	4 1/2"	8 9/10"	1"
5"	W2-RC5	810003716	5 4/5"	11 3/10"	1"
6"	W2-RC6	810003736	6 4/5"	13 1/2"	1"
7"	W2-RC7	810003757	7 4/5"	15 4/5"	1"
8"	W2-RC8	810003777	8 4/5"	18"	1"
9"	W2-RC9	810003800	10"	20 3/10"	1"
10"	W2-RC10	810012601	5"	16 3/4"	5 3/8"
12"	W2-RC12	810009880	6"	20"	5 1/16"
14"	W2-RC14	810009881	7"	23 1/2"	6"
16"	W2-RC16	810009882	8"	26 3/4"	6 1/5"

Termination Cone

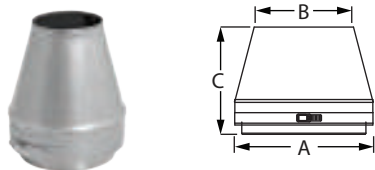

Use for vertical termination. Creates static back pressure to adjust harmonics. Venturi effect increases velocity of flue gases. Reduced opening provides for a smaller cross section to deter rain from entering the system. **Available in custom size combinations.**

SIZE	ORDER #	STOCK #	A	B	C
8" x 6"	W2-CN0806	810003778	8"	6"	6 3/8"
14" x 12"	W2-CN1412	810003870	14"	12"	6 3/8"

Stepped Increaser

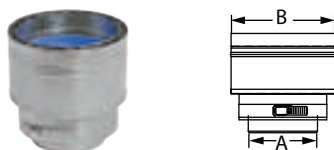

Use to increase vent diameter when space constraints are an issue. **Available in custom size combinations.**

Available in 316L Stainless Steel

SIZE	ORDER #	STOCK #	A	B
4" x 5"	W2-45I	810003696	4"	5"
8" x 9"	W2-89I	810003779	8"	9"

Tapered Increaser



Use to increase vent diameter. Creates a smooth transition for an undistruptive flow. **Additional sizes available up to a maximum of 10" diameter change. *Available in 316L Stainless Steel***

SIZE	ORDER #	STOCK #	A	B
3" x 4"	W2-0304TI	810003674	3"	4"
3" x 6"	W2-0306TI	810003675	3"	6"

Eccentric Increaser

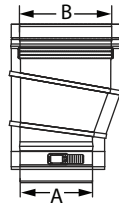

Use to transition to a larger diameter pipe. Adjusts the systems center point to offset from obstructions. Aids in reducing formation of condensates on horizontal runs. FasNSeal W2 has a 10" max change in diameter. **Additional sizes available up to a maximum of 10" diameter change.**

Available in 316L Stainless Steel

SIZE	ORDER #	STOCK #	A	B
8" x 10"	W2-0810E1	810003781	8"	10"

Stepped Reducer

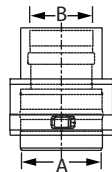

Use to reduce vent diameter when space constraints are an issue. **Available in custom size combinations.**

SIZE	ORDER #	STOCK #	A	B
7" x 5"	W2-75R	810003758	7"	5"
12" x 10"	W2-1210R	810003847	12"	10"

Tapered Reducer

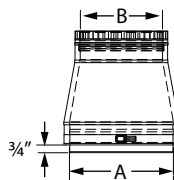

Use to reduce vent diameter. Creates a smooth transition for an undistruptive flow. FasNSeal W2 has a 10" max change in diameter. **Additional sizes available up to a maximum of 10" diameter change. *Available in 316L Stainless Steel***

SIZE	ORDER #	STOCK #	A	B
8" x 7"	W2-0807TR	810003780	8"	7"
10" x 7"	W2-1007TR	810003822	10"	7"

Single-Wall Adapter

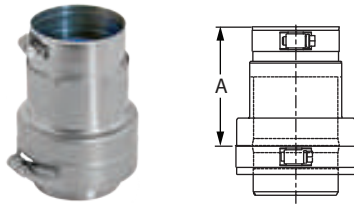

Use to transition from double-wall pipe to single-wall pipe. To transition from single-wall to double-wall, please reference double-wall adapter available in single-wall FasNSeal section.

Available in 316L Stainless Steel

SIZE	ORDER #	STOCK #	A	SIZE	ORDER #	STOCK #	A
3"	FSA-DWSW3	810003676	4"	9"	FSA-DWSW9	810003801	4"
4"	FSA-DWSW4	810003697	4"	10"	FSA-DWSW10	810003821	4"
5"	FSA-DWSW5	810003717	4"	12"	FSA-DWSW12	810003846	4"
6"	FSA-DWSW6	810003737	4"	14"	FSA-DWSW14	810003871	4"
7"	FSA-DWSW7	810003759	4"	16"	FSA-DWSW16	810003893	4"
8"	FSA-DWSW8	810003782	4"				

Firestop/Flat Flashing

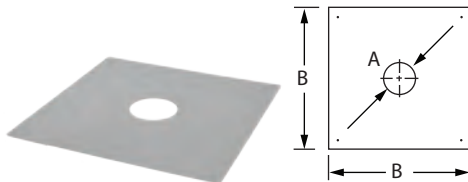

Use when penetrating floor levels. When installing double-wall with this component use 1" larger diameter, (e.g. 10" vent system, use 11" size).

SIZE	ORDER #	STOCK #	A	B	SIZE	ORDER #	STOCK #	A	B
4"	FSFS4	810003181	4 1/4"	15"	11"	FSFS11	810003823	11 3/5"	24"
5"	FSFS5	810003234	5 3/5"	17"	12"	FSFS12	810003492	12 3/5"	24"
6"	FSFS6	810003287	6 3/5"	17"	13"	FSFS13	810003848	13 3/5"	26"
7"	FSFS7	810003331	7 3/5"	19"	14"	FSFS14	810003532	14 3/5"	26"
8"	FSFS8	810003374	8 3/5"	19"	15"	FSFS15	810003872	15 3/5"	28"
9"	FSFS9	810003413	9 3/5"	22"	16"	FSFS16	810003567	16 3/5"	28"
10"	FSFS10	810003451	10 3/5"	22"					

Wall Bracket

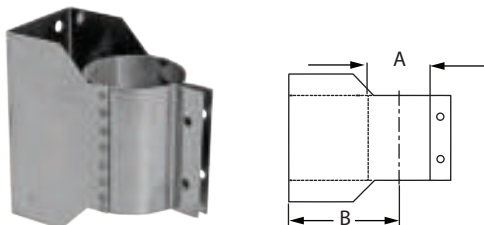

Use to support vent pipe or tee sections. Provides proper clearance to combustibles. When installing FasNSeal W2 with this component use 1" larger diameter, (e.g. 10" vent system, use 11" size).

SIZE	ORDER #	STOCK #	A	B	SIZE	ORDER #	STOCK #	A	B
4"	FSWB4	810003183	4"	4"	11"	FSWB11	810003826	11"	7 1/2"
5"	FSWB5	810003236	5"	4 1/2"	12"	FSWB12	810003494	12"	8"
6"	FSWB6	810003289	6"	5"	13"	FSWB13	810003850	13"	8 1/2"
7"	FSWB7	810003333	7"	5 1/2"	14"	FSWB14	810003534	14"	9"
8"	FSWB8	810003376	8"	6"	15"	FSWB15	810003874	15"	9 1/2"
9"	FSWB9	810003415	9"	6 1/2"	16"	FSWB16	810003569	16"	10"
10"	FSWB10	810003453	10"	7"					

Bird Screen

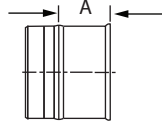

Use for 3" and 4" standard through-the-wall terminations. Check installation instructions for restrictions on horizontal terminations, such as minimum distance from windows and doors.

Available in 316L Stainless Steel

SIZE	ORDER #	STOCK #	A
3"	FSBS3	810003120	2"
4"	FSBS4	810003174	2"

23° Bird Screen

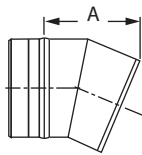

Use for 5" to 16" through-the-wall termination. Deters rain and other elements from entering the vent system. Check installation instructions for restrictions on horizontal terminations, such as minimum distance from windows and doors.

Available in 316L Stainless Steel

SIZE	ORDER #	STOCK #	A
5"	FSBS5	810003229	4 4/5"
6"	FSBS6	810003281	5 3/5"
7"	FSBS7	810003327	6 2/5"
8"	FSBS8	810003369	7 1/10"
9"	FSBS9	810003409	7 9/10"
10"	FSBS10	810003447	8 7/10"
12"	FSBS12	810003488	10 1/5"
14"	FSBS14	810003528	11 7/10"
16"	FSBS16	810003563	13 1/5"

Termination Tee

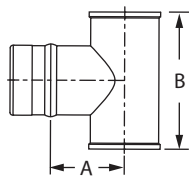

Use for standard and high-wind through-the-wall terminations. Check installation instructions for restrictions on horizontal terminations, such as minimum distance from windows and doors.

Available in 316L Stainless Steel

SIZE	ORDER #	STOCK #	A	B
3"	FSTT3	810003121	3"	6"
4"	FSTT4	810003175	3 1/2"	7"
5"	FSTT5	810003230	4"	8"
6"	FSTT6	810003282	4 1/2"	9"

Termination Box

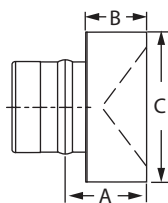

Use for horizontal through-the-wall terminations. Check installation instructions for restrictions on horizontal terminations, such as minimum distance from windows and doors.

Available in 316L Stainless Steel

SIZE	ORDER #	STOCK #	A	B	C
3"	FSTB3	810003122	2 3/10"	2"	5"
4"	FSTB4	810003176	2 3/10"	2"	6"

Storm Collar



Use to create a weather tight seal between the pipe and flashing. When installing FasNSeal W2 with this component use 1" larger diameter, (e.g. 10" vent system, use 11" size).

SIZE	ORDER #	STOCK #	SIZE	ORDER #	STOCK #
4"	FSC4	810003188	9"	FSC9	810003419
5"	FSC5	810003239	10"	FSC10	810003460
6"	FSC6	810003293	11"	FSC11	810003827
7"	FSC7	810003336	13"	FSC13	810003852
8"	FSC8	810003381	15"	FSC15	810003875

Variable Pitch Roof Flashing

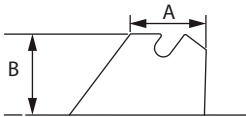

Use to create a weather-tight penetration where the vent pipe passes through the roof. Storm Collar required. When ordering Flashings for FasNSeal W2 product the flashing diameter and vent diameter are the same. ie. W2-3610 requires a FSVPF10. Accommodates flat to 9/12 roof pitch.

SIZE	ORDER #	STOCK #	A	B	SIZE	ORDER #	STOCK #	A	B
4"	FSVPF4	810003190	6"	7"	9"	FSVPF9	810003421	11"	7"
5"	FSVPF5	810003241	7"	7"	10"	FSVPF10	810003462	12"	7"
6"	FSVPF6	810003295	8"	7"	12"	FSVPF12	810003503	14"	7"
7"	FSVPF7	810003338	9"	7"	14"	FSVPF14	810003540	16"	7"
8"	FSVPF8	810003383	10"	7"	16"	FSVPF16	810003574	18"	7"

Tall Cone Flashing

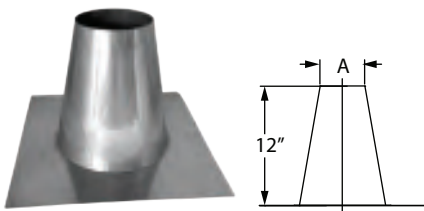

Use to create a weather-tight penetration where the vent pipe passes through a flat roof. Storm Collar required. When ordering Flashings for FasNSeal W2 product the flashing diameter and vent diameter are the same. ie. W2-3610 requires a FSVPF10.

SIZE	ORDER #	STOCK #	A	SIZE	ORDER #	STOCK #	A
3"	FSAF3	810005257	4 1/3"	9"	FSAF9	810005263	10 1/3"
4"	FSAF4	810005258	5 1/3"	10"	FSAF10	810005264	11 1/3"
5"	FSAF5	810005259	6 1/3"	12"	FSAF12	810005269	13 1/3"
6"	FSAF6	810005260	7 1/3"	14"	FSAF14	810005270	15 1/3"
7"	FSAF7	810005261	8 1/3"	16"	FSAF16	810005271	17 1/3"
8"	FSAF8	810005262	9 1/3"				