



Installation and Operation Manual

ESCAPE 1500

(DB03135 model)

ENGLISH

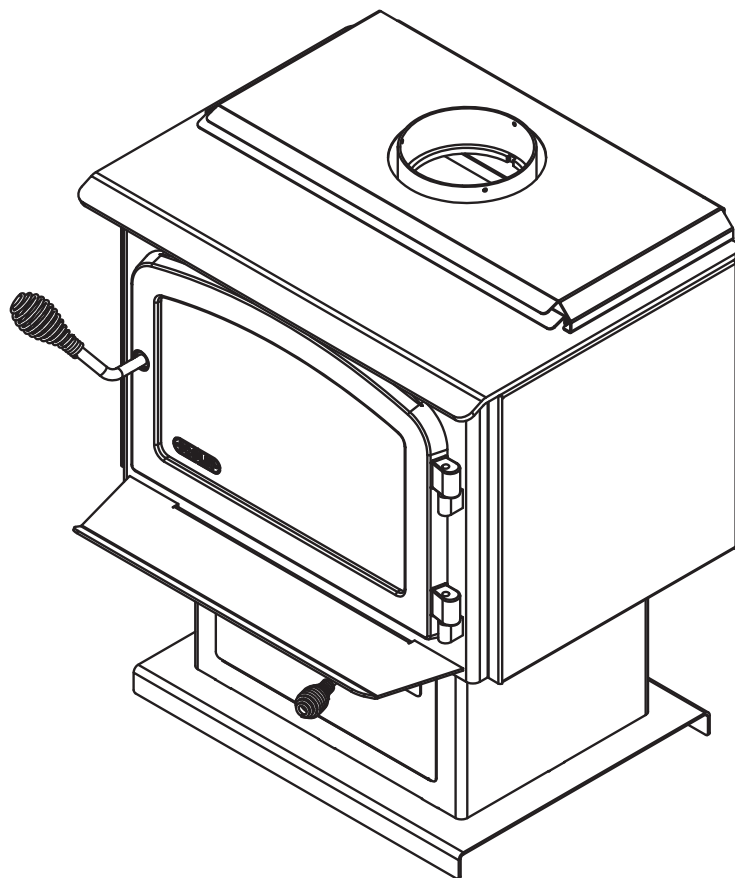

US Environmental Protection Agency
phase II certified wood stove compliant
with 2020 cord wood standard



Safety tested according to ULC S627,
UL 1482 and UL 737 standards by an
accredited laboratory.



CONTACT LOCAL BUILDING OR FIRE OFFICIALS ABOUT RESTRICTIONS AND INSTALLATION INSPECTION REQUIREMENTS IN LOCAL AREA.

READ THIS ENTIRE MANUAL BEFORE INSTALLATION AND USE OF THIS WOOD STOVE. FAILURE TO FOLLOW THESE INSTRUCTIONS COULD RESULT IN PROPERTY DAMAGE, BODILY INJURY OR EVEN DEATH.

READ AND KEEP THIS MANUAL FOR REFERENCE

THANK YOU FOR CHOOSING THIS WOOD STOVE.

If this stove is not installed properly, combustible materials near it may overheat and catch fire.

To reduce the risk of fire, follow the installation instructions in this manual.

As one of North America's largest and most respected wood stove and fireplace manufacturers, Stove Builder International takes pride in the quality and performance of all its products.

The following pages provide general advice on wood heating, detailed instructions for safe and effective installation, and guidance on how to get the best performance from this stove.

It is highly recommended that this wood burning hearth product be installed and serviced by professionals who are certified by a «Qualified Agency» such as NFI (National Fireplace Institute®) or CSIA (Chimney Safety Institute of America) in the United States and in Canada by WETT (Wood Energy Technology Transfer) or in Quebec by APC (Association des Professionnels du Chauffage).

Contact local building or fire officials about restrictions and installation inspection requirements in your local area.

A building permit might be required for the installation of this stove and the chimney that it is connected to. It is also highly recommended to inform your home insurance company.

Please read this entire manual before installing and using this stove.

A primary alternative heat source should be available in the home. This heating unit may serve as a supplementary heat source. The manufacturer cannot be responsible for additional heating costs associated with the use of an alternative heat source.

ENGLISH

ONLINE WARRANTY REGISTRATION

If the unit requires repairs during the warranty period, proof of purchase must be provided. The purchase invoice must be kept. The date indicated on it establishes the warranty period. If it cannot be provided, the warranty period will be determined by the date of manufacture of the product. It is also highly recommended to register the warranty online at

<https://www.drolet.ca/en/warranty/warranty-registration/>

Registering the warranty will help to quickly find the information needed on the unit.

TABLE OF CONTENTS

PART A - OPERATION AND MAINTENANCE	7
1. Safety Information.....	7
2. General Information	8
2.1 Performances.....	8
2.2 Specifications.....	9
2.3 Dimensions	10
2.4 Materials	11
2.5 Zone Heating	11
2.6 Emissions and Efficiency	12
3. Fuel	12
3.1 Tree Species	12
3.2 Log Length	13
3.3 Log Size	13
3.4 Compressed Wood Logs.....	13
3.5 Drying Time.....	14
4. Operating the Stove	15
4.1 The Use of a Fire Screen.....	15
4.2 Blower Operation	15
5. Burning Wood Efficiently	16
5.1 First Use	16
5.2 Lighting Fires	16
5.3 Combustion Cycles.....	17
5.4 Rekindling a Fire.....	18
5.5 Removing Ashes.....	18
5.6 Air Intake Control.....	19
5.7 Fire Types	19
6. Maintenance.....	21
6.1 Cleaning and Painting	21
6.2 Refractory Materials and Baffle.....	21
6.3 Glass Door.....	21
6.4 Door	23
6.5 Exhaust System	24
PART B - INSTALLATION.....	26
7. Safety Information and Standards	26
7.1 Mobile Home.....	26
7.2 Regulations Covering Stove Installation.....	26
7.3 Location of the Certification Label	27

8. Clearances to Combustible Material..... 27

8.1 Clearances.....29

8.2 Floor Protection.....32

8.3 Reducing Clearances Safely32

9. The Venting System 36

9.1 General36

9.2 Suitable Chimneys.....36

9.3 Minimum Chimney Height.....38

9.4 Chimney Location.....38

9.5 Supply of Combustion Air39

9.6 Installing the Chimney Connector40

Appendix 1: Optional Fresh Air Intake Kit Installation 42

Appendix 2: Optional Fire Screen Installation..... 43

Appendix 3: Optional Blower Installation..... 44

Appendix 4: Optional Thermodisc Installation..... 45

Appendix 5: Removing the Decorative Panels..... 46

Appendix 6: Air Tubes and Baffle Installation 47

Appendix 7: Mobile Home Installation 49

Appendix 8: Exploded Diagram and Parts List..... 50

DROLET Limited Lifetime Warranty..... 53

Dealer: _____

Installer: _____

Phone Number: _____

Serial Number: _____

CERTIFICATION PLATE



Intertek
December/Décembre 2018
Control number: 4002461

REFER TO INTERTEK'S DIRECTORY OF BUILDING PRODUCTS FOR DETAILED INFORMATION
SE REFERER AU REPERTOIRE DES PRODUITS HOMOLOGUÉS D'INTERTEK POUR PLUS D'INFORMATION

STANDARDS / NORMES D'ESSAI:
Certified to/Certifié selon ULC S627
Certified to/Certifié selon UL 1482
Certified to/Certifié selon UL 737
Certified to/Certifié selon CSA B415.1-10

Certified to/Certifié selon ASTM E2515-11 (R2017)

LISTED SOLID FUEL BURNING APPLIANCE

POÊLE À COMBUSTIBLE SOLIDE HOMOLOGUÉ

MODEL / MODÈLE :

ESCAPE 1500

Serial Number / No. de Série: **1**

Clearances to combustibles / Dégagements aux combustibles

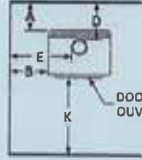

CANADA

Single wall connector Tuyau à paroi simple	Double wall connector Tuyau à paroi double
A: 14.5 in./po. (368 mm)	A: 6 in./po. (152 mm)
B: 10 in./po. (254 mm)	B: 10 in./po. (254 mm)
C: 12 in./po. (305 mm)	C: 6 in./po. (152 mm)
D: 18 in./po. (457 mm)	D: 9.5 in./po. (241 mm)
E: 19 in./po. (483 mm)	E: 19 in./po. (483 mm)
F: 20.75 in./po. (527 mm)	F: 14.75 in./po. (375 mm)

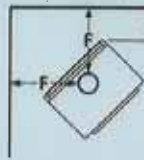

U.S.A.

MOBILE HOME MAISONS MOBILES Double wall connector Tuyau à paroi double
A: 8 in./po. (203 mm)
B: 14.5 in./po. (368 mm)
C: 12 in./po. (305 mm)
D: 11.5 in./po. (292 mm)
E: 23.5 in./po. (597 mm)
F: 20.75 in./po. (527 mm)

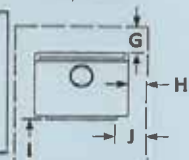

Protection de plancher/Floor protection
G: 8 in./po. (203 mm)
H: 8 in./po. (203 mm)
I: 18 in./po. (457 mm)
J: 8 in./po. (203 mm)
K: 36 in./po. (914 mm)

Floor-ceiling/plancher-plafond: 84 in./po. (213cm)

* See Owner's Manual for other clearances with lowered ceiling / voir manuel d'installation pour autres dégagements avec plafond abaissé

PREVENT HOUSE FIRES

- Install and use only in accordance with the manufacturer's Installation and operating instructions.
- Contact local building or fire officials about restrictions and installation inspection in your area.
- Use listed 152 mm / 6 in. diameter single or double wall connectors with prefabricated chimneys approved UL 103 HT (US) and ULC S629 (CAN) suitable for solid fuels or lined masonry chimneys.
- See local building code and manufacturer's Instructions for precautions required for passing a chimney through a combustible wall or ceiling.
- Do not pass connector through combustible wall or ceiling.
- Do not connect this unit to a chimney serving another appliance.
- For use with solid fuel only. Do not use other fuels.
- Operate only with door closed or door open with firescreen installed. Open door or remove firescreen to feed the stove only.
- Do not obstruct the space underneath the stove.
- Do not use grates or elevate fire. Build fire directly on hearth.
- Do not overfire. If heater or chimney connector glows, you are overfiring.
- Inspect and clean chimney frequently. Under certain condition of use, creosote buildup may occur rapidly.
- Replace glass with ceramic type only.
- Install unit on a non-combustible material extending as shown above on this label.
- Suitable for mobile-home installation.
- Combustion air openings shall not be obstructed.
- This wood heater needs periodic inspection and repair for proper operation. Consult the owner's manual for further information. It is against US federal regulations to operate this wood heater in a manner inconsistent with the operating instructions in the owner's manual.

PRÉVENIR LES INCENDIES

- Installer et utiliser conformément au manuel d'utilisation du fabricant.
- Contacter les autorités de votre localité ayant juridiction concernant les restrictions et inspections d'installation.
- Utiliser des tuyaux d'évacuation à parois simple ou double homologués d'un diamètre de 6 po. (152 mm) avec une cheminée préfabriquée approuvée UL 103 HT (US) et ULC S629 (CAN) pour utilisation au bois ou une cheminée de maçonnerie gainée.
- Voir les codes locaux et le manuel d'installation du fabricant pour le passage de la cheminée à travers un mur ou un plafond combustible.
- Ne pas traverser un plafond ou un mur combustible avec un tuyau d'évacuation.
- Ne pas raccorder cet appareil à une cheminée desservant un autre appareil.
- Pour l'usage avec du combustible solide seulement. Ne pas utiliser d'autres combustibles.
- Garder la porte fermée ou le pare-étincelle en place en tout temps. Ouvrir la porte ou retirer le pare-étincelle que lors du chargement.
- Ne rien entreposer sous l'appareil.
- Ne pas utiliser de grilles ou de chenets pour surélever le feu. Préparer le feu directement sur l'âtre.
- Ne pas surchauffer. Si l'appareil ou le tuyau rougit, il y a surchauffe.
- Inspecter et nettoyer la cheminée fréquemment. Sous certaines conditions, l'accumulation de crésote peut être rapide.
- Remplacer la vitre seulement avec un verre de céramique.
- Installer l'appareil sur une plaque non combustible tel qu'indiqué sur l'étiquette.
- Poêle approuvé pour maison mobile.
- Les entrées d'air servant à la combustion ne doivent pas être obstruées.
- Cet appareil de chauffage requiert des inspections et réparations périodiques. Consulter le manuel de l'utilisateur pour plus d'information. Opérer cet appareil de chauffage de façon inconsistante par rapport au manuel de l'utilisateur consiste une violation de la loi fédérale (USA).

Optional blower: (115V, 0.8A, 60Hz)

Option ventilateur: (115V, 0.8A, 60Hz)

U.S. ENVIRONMENTAL PROTECTION AGENCY Certified to comply with 2020 particulate emission standards using cordwood.

AGENCE DE PROTECTION DE L'ENVIRONNEMENT DES É.-U. Conforme aux normes d'émission de particules de 2020 avec bûche de bois.

Weighted average emission rate / Moyenne pondérée des émissions : 1.26 g/h

Tested and certified in compliance with CFR 40 part 60, subpart AAA, section 60.534(a)(1)(ii)

WARNING: This product can expose you to carbon monoxide, which is known to the State of California to cause cancer, birth defects or other reproductive harm. (For more information go to www.p65warnings.ca.gov)



CAUTION

- HOT WHILE IN OPERATION.
- DO NOT TOUCH. KEEP CHILDREN, CLOTHING AND FURNITURE AWAY.
- CONTACT MAY CAUSE SKIN BURNS. SEE NAME-PLATE AND INSTRUCTIONS

ATTENTION

- CHAUD EN FONCTIONNEMENT.
- NE PAS TOUCHER. GARDER LES ENFANTS, LES VÊTEMENTS ET LES MEUBLES ÉLOIGNÉS.
- UN CONTACT AVEC LA PEAU PEUT OCCASIONNER DES BRÛLURES. VOIR LES INSTRUCTIONS.

Made in St-Augustin-de-Desmaures (Qc), Canada
05/05/2021 (# test)



Fabricant de poêles International
Stove Builder International

Fabriqué à St-Augustin-de-Desmaures (Qc), Canada
05/05/2021 (# test)

27761

ENGLISH

PART A - OPERATION AND MAINTENANCE

1. Safety Information

- This stove has been tested for use with an open door in conjunction with a fire screen, sold separately. The door may be opened, or fire screen removed only during lighting procedures or reloading. Always close the door or put back on the fire screen after ignition. Do not leave the stove unattended when the door is opened with or without the fire screen.
- **WARNING : OPERATE ONLY WITH THE DOOR FULLY CLOSED OR FULLY OPEN WITH THE FIRE SCREEN IN PLACE. IF THE DOOR IS LEFT PARTLY OPEN, GAS AND FLAME MAY BE DRAWN OUT OF THE OPENING, CREATING RISKS FROM BOTH FIRE AND SMOKE.**
- **HOT WHILE IN OPERATION, KEEP CHILDREN, CLOTHING AND FURNITURE AWAY. CONTACT MAY CAUSE SKIN BURNS. GLOVES MAY BE NEEDED FOR THE STOVE OPERATION.**
- Using a stove with cracked or broken components, such as glass, firebricks or baffle may produce an unsafe condition and may damage the stove.
- Open the air control fully before opening the loading door.
- **NEVER USE GASOLINE, LANTERN FUEL (NAPHTHA), FUEL OIL, MOTOR OIL, KEROSENE, CHARCOAL LIGHTER FLUID, OR SIMILAR LIQUIDS OR AEROSOLS TO START A FIRE IN THIS STOVE. KEEP ALL SUCH LIQUIDS OR AEROSOLS WELL AWAY FROM THE STOVE WHILE IT IS IN USE.**
- Do not store fuel within heater minimum installation clearances.
- Burn only seasoned natural firewood.
- This appliance should always be maintained and operated in accordance with these instructions.
- Do not elevate the fire by using a grate.
- Do not use makeshift materials or make any compromises when installing this appliance.
- This wood heater needs periodic inspection and repairs for the proper operation. It is against federal regulations to operate this wood heater in a manner inconsistent with operating instructions in this manual.
- A smoke detector, a carbon monoxide detector and a fire extinguisher should be installed in the house. The location of the fire extinguisher should be known by all family members.



This product can expose you to chemicals including carbon monoxide, which is known to the State of California to cause cancer, birth defects or other reproductive harm. For more information go to www.P65warnings.ca.gov/

2. General Information

2.1 Performances

Values are as measured per test method, except for the recommended heating area, firebox volume, maximum burn time and maximum heat output.

ENGLISH

Model	ESCAPE 1500 (DB03135)	
Combustion Technology	Non-catalytic	
Fuel Type	Dry Cordwood	
Recommended heating area (sq. ft.) ¹	500 to 1,800 ft ² (46 to 167 m ²)	
Nominal firebox volume	1.9 ft ³ (0.054 m ³)	
Maximum burn time ¹	6 hours	
Maximum heat output (dry cordwood) ²	65,000 BTU/h (19 kW)	
Overall heat output rate (min. to max.) ^{2 3}	15,650 BTU/h to 23,300 BTU/h (4.6 kW to 6.83 kW)	
Average overall efficiency ³ Dry cordwood	70 % (HHV) ⁴	75 % (LHV) ⁵
Optimum efficiency ⁶	78 %	
Average particulate emissions rate ⁷	1.26 g/h (EPA / CSA B415.1-10) ⁸	
Average CO ⁹	58 g/h	

¹ Recommended heating area and maximum burn time may vary subject to location in home, chimney draft, heat loss factors, climate, fuel type and other variables. The recommended heated area for a given appliance is defined by the manufacturer as its capacity to maintain a minimum acceptable temperature in the designated area in case of a power failure.

² The maximum heat output (dry cordwood) is based on a loading density varying between 15 lb/ft³ and 20 lb/ft³. Other performances are based on a fuel load prescribed by the standard. The specified loading density varies between 7 lb/ft³ and 12 lb/ft³. The moisture content is between 19% and 25%.

³ As measured per CSA B415.1-10 stack loss method.

⁴ Higher Heating Value of the fuel.

⁵ Lower Heating Value of the fuel.

⁶ Optimum overall efficiency at a specific burn rate (LHV).

⁷ This appliance is officially tested and certified by an independent agency.

⁸ Tested and certified in compliance with CFR 40 part 60, subpart AAA, section 60.534(a)(1)(ii) and draft ASTM WK47329-14

⁹ Carbon monoxide.

2.2 Specifications

Maximum log length ¹⁰	18 in (457 mm) east-west
Flue outlet diameter	6 in (150 mm)
Recommended connector pipe diameter	6 in (150 mm)
Type of chimney	ULC S629, UL 103 HT (2100 °F)
Baffle material	Vermiculite
Approved for alcove installation	Yes
Approved for mobile home installation ¹¹	Yes
Type of door	Simple, glass with cast iron frame
Type of glass	Ceramic glass
Blower	Optional (up to 100 CFM)
Particulate emission standard ¹²	EPA / CSA B415.1-10
USA standard (Safety)	UL 1482, UL 737
Canada standard (Safety)	ULC S627

¹⁰ North-south: ends of the logs visible, East-west: sides of the logs visible.

¹¹ Mobile homes (Canada) or manufactured homes (USA): The US Department of Housing and Urban Development describes “manufactured homes” better known as “mobile homes” as follows; buildings built on fixed wheels and those transported on temporary wheels/axles and set on a permanent foundation. In Canada, a mobile home is a dwelling for which the manufacture and assembly of each component is completed or substantially completed prior to being moved to a site for installation on a foundation and connection to service facilities and which conforms to the CAN/CSA-Z240 MH standard.

¹² Tested and certified in compliance with CFR 40 part 60, subpart AAA, section 60.534(a)(1)(ii) and draft ASTM WK47329-14.

2.3 Dimensions

ENGLISH

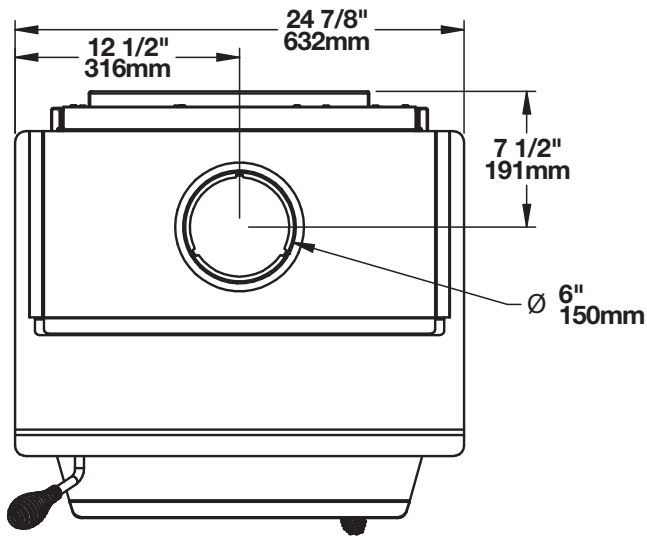

Figure 1: Top view

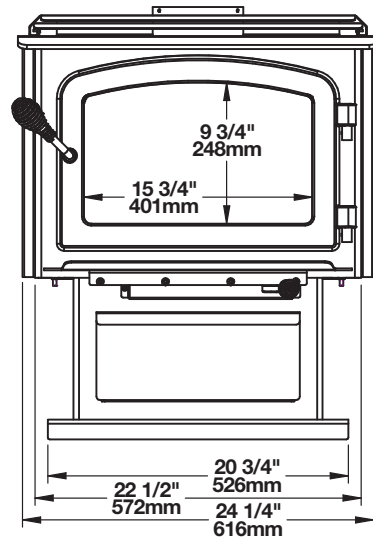

Figure 2: Front view

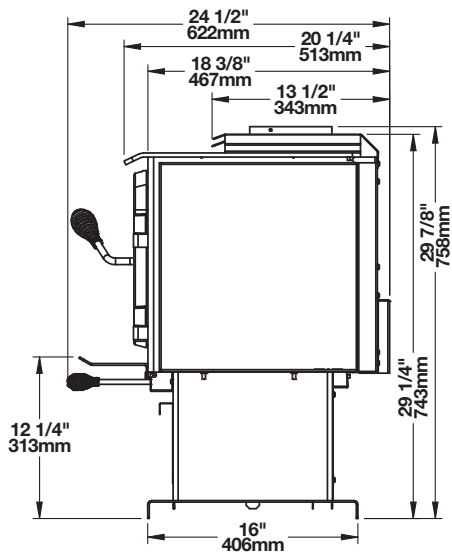

Figure 3: Side view

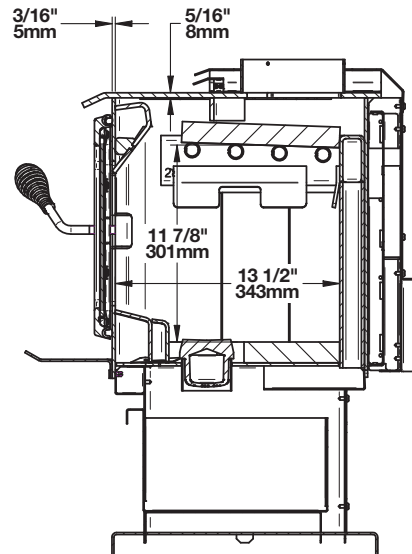

Figure 4: Combustion chamber - side view

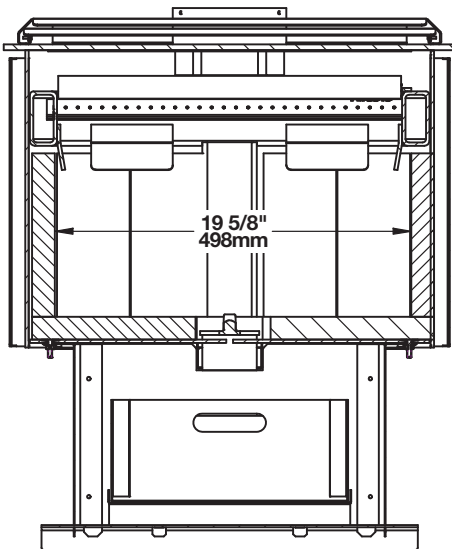

Figure 5: Combustion chamber - front view

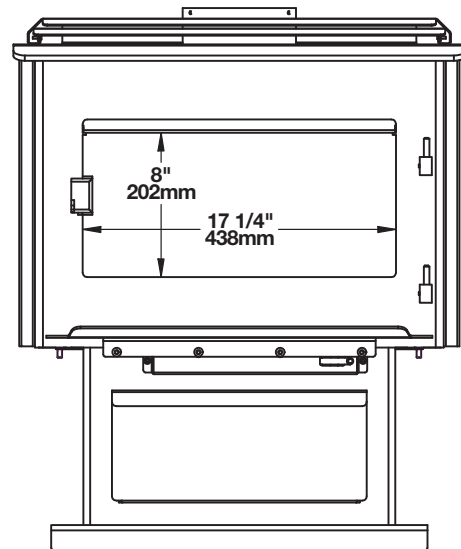

Figure 6: Door opening

2.4 Materials

The **body** of this stove, which is most of its weight, is carbon steel. Should it ever become necessary many years in the future, almost the entire stove can be recycled into new products, thus eliminating the need to mine new materials.

The **paint** coating on the stove is very thin. Its VOC content (Volatile Organic Compounds) is very low. VOCs can be responsible for smog, so all the paint used during the manufacturing process meets the latest air quality requirements regarding VOC reduction or elimination.

The **air tubes** are stainless steel, which can also be recycled.

The **baffle** is made of vermiculite compressed with a binder to form a rigid board. Vermiculite can withstand temperatures above 2,000°F. It is not considered hazardous waste. Disposal at a waste management center is recommended.

The firebrick is made of pumice, a volcanic rock, and cement. Disposal at a waste management center is recommended.

The door and glass **gaskets** are fibreglass which is spun from melted sand. Black gaskets are dipped into a solvent-free solution. Disposal at a waste management center is recommended.

The door **glass** is a 5/32" (4 mm) thick ceramic material that contains no toxic chemicals. It is made of natural raw materials such as sand and quartz that are combined in such a way to form a high temperature glass. Ceramic glass cannot be recycled in the same way as normal glass, so it should not be disposed of with regular household products. Disposal at a waste management center is recommended.

2.5 Zone Heating

This stove is a space heater, which means it is intended to heat the area it is installed in, as well as spaces that connect to that area, although to a lower temperature. This is called zone heating and it is an increasingly popular way to heat homes or spaces within homes.

Zone heating can be used to supplement another heating system by heating a particular space within a home, such as a basement, a family room or an addition that lacks another heat source.

Houses of moderate size and relatively new construction can be heated with a properly sized and located wood stove. Whole house zone heating works best when the stove is in the part of the house where the family spends most of its time. This is normally the main living area where the kitchen, dining and living rooms are located.

Locating the stove in this area will give the maximum benefit of the heat it produces and will achieve the highest possible heating efficiency and comfort. The space where the most time is spent will be warmest, while bedrooms and basement (if there is one) will stay cooler. In this way, less wood is burnt than with other forms of heating.

Although the stove may be able to heat the main living areas of the house to an adequate temperature, it is strongly recommended to also have a conventional oil, gas or electric heating system to provide backup heating.

The success of zone heating will depend on several factors, including the correct sizing and location of the stove, the size, layout and age of the home and the climate zone. Three-season vacation homes can usually be heated with smaller stoves than houses that are heated all winter.

2.6 Emissions and Efficiency

The low smoke emissions produced by the special features inside this stove firebox mean that the household will release up to 90% less smoke into the outside environment than if an older conventional stove was used. But there is more to the emission control technologies than protecting the environment.

The smoke released from wood when it is heated contains about half of the energy content of the fuel. By burning the wood completely, this stove releases all the heat energy from the wood instead of wasting it as smoke up the chimney. Also, the features inside the firebox allow control of the air supply meaning controlling the heat output, while maintaining clean and efficient flaming combustion, which boosts the efficient delivery of heat to the home.

The emission control and advanced combustion features of this stove can only work properly if the fuel used is in the correct moisture content range of 15% to 20%. Refer to the following section for suggestions on preparing fuelwood and judging its moisture.

3. Fuel

Good firewood has been cut to the correct length for the stove, split to a range of sizes and stacked outside to air dry until its moisture content is down to 15% to 20%.

DO NOT BURN:

- **GARBAGE;**
- **LAWN CLIPPINGS OR YARD WASTE;**
- **MATERIALS CONTAINING RUBBER, INCLUDING TIRES;**
- **MATERIALS CONTAINING PLASTIC;**
- **WASTE PETROLEUM PRODUCTS, PAINTS OR PAINT THINNERS, OR ASPHALT PRODUCTS;**
- **MATERIALS CONTAINING ASBESTOS;**
- **CONSTRUCTION OR DEMOLITION DEBRIS;**
- **RAILROAD TIES OR PRESSURE-TREATED WOOD;**
- **MANURE OR ANIMAL REMAINS;**
- **SALT WATER DRIFTWOOD OR OTHER PREVIOUSLY SALT WATER SATURATED MATERIALS;**
- **UNSEASONED WOOD; OR**
- **PAPER PRODUCTS, CARDBOARD, PLYWOOD, OR PARTICLE BOARD. THE PROHIBITION AGAINST BURNING THESE MATERIALS DOES NOT PROHIBIT THE USE OF FIRE STARTERS MADE FROM PAPER, CARDBOARD, SAW DUST, WAX AND SIMILAR SUBSTANCES FOR THE PURPOSE OF STARTING A FIRE IN AN AFFECTED WOOD HEATER.**

BURNING THESE MATERIALS MAY RESULT IN THE RELEASE OF TOXIC FUMES OR RENDER THE HEATER INEFFECTIVE AND CAUSE SMOKE.

3.1 Tree Species

The tree species the firewood is produced from is less important than its moisture content. The main difference in firewood from various tree species is the density of the wood. Hardwoods are denser than softwoods.

Homeowners with access to both hardwood and softwood use both types for different purposes.

Softer woods make good fuel for mild weather in spring and fall because they light quickly and produce less heat. Softwoods are not as dense as hardwoods so a given volume of wood contains less energy. Using softwoods avoids overheating the house, which can be a common problem with wood heating in moderate weather. Harder woods are best for colder winter weather when more heat and longer burn cycles are desirable.

Note that hardwood trees like oak, maple, ash and beech are slower growing and longer lived than softer woods like poplar and birch. That makes hardwood trees more valuable. The advice that only hardwoods are good to burn is outdated. Old, leaky cast iron stoves wouldn't hold a fire overnight unless they were fed large pieces of hardwood.

3.2 Log Length

Logs should be cut at least 1" (25 mm) shorter than the firebox so they fit in easily. Pieces that are even slightly too long makes loading the stove very difficult. The most common standard length of firewood is 16" (400 mm).

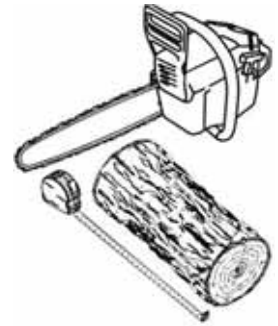

3.3 Log Size

Firewood dries more quickly when it is split. Large unsplit rounds can take years to dry enough to burn. Even when dried, unsplit logs are difficult to ignite because they don't have the sharp edges where the flames catch first.

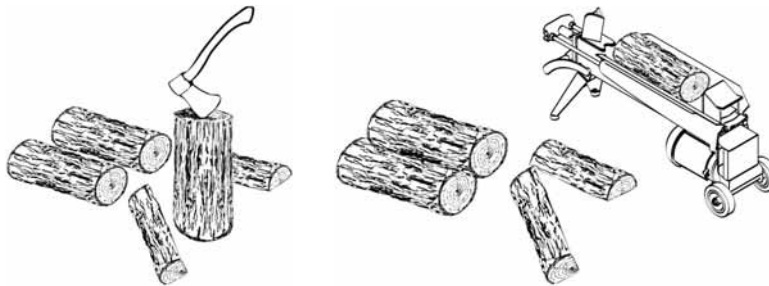

Wood should be split to a range of sizes, from about 3" to 6" (75 mm to 150 mm) in cross section. Having a range of sizes makes starting and rekindling fire much easier.

3.4 Compressed Wood Logs

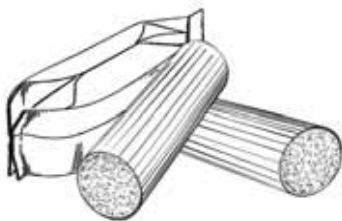

Compressed wood logs made of 100% compressed sawdust can be burned with caution in the number of these logs burned at once. Do not burn compressed logs made of wax impregnated sawdust or logs with any chemical additives. Follow the manufacturer's instructions and warnings.

3.5 Drying Time

Firewood that is not dry enough to burn is the cause of most complaints about wood burning appliances. Continually burning green or unseasoned wood produces more creosote and involves lack of heat and dirty glass door.

Firewood with a moisture content between 15% and 20% will allow the stove to produce its highest possible efficiency.

Here are some facts to consider in estimating drying time:

- Firewood bought from a dealer is rarely dry enough to burn, so it is advisable to buy the wood in spring and dry it yourself;
- Drying happens faster in dry weather than in a damp climate;
- Drying happens faster in warm summer weather than in winter weather;
- Split pieces dry more quickly than unsplit rounds;
- Softwoods like pine, spruce, poplar, and aspen take less time to dry than hardwoods. They can be dry enough to burn after being stacked to air dry only for the summer months;
- Hardwoods like oak, maple and ash can take one, or even two years to dry fully, especially if the pieces are big;
- Firewood dries more quickly when stacked outside in a location exposed to sun and wind; it takes much longer to dry when stacked in a wood shed.

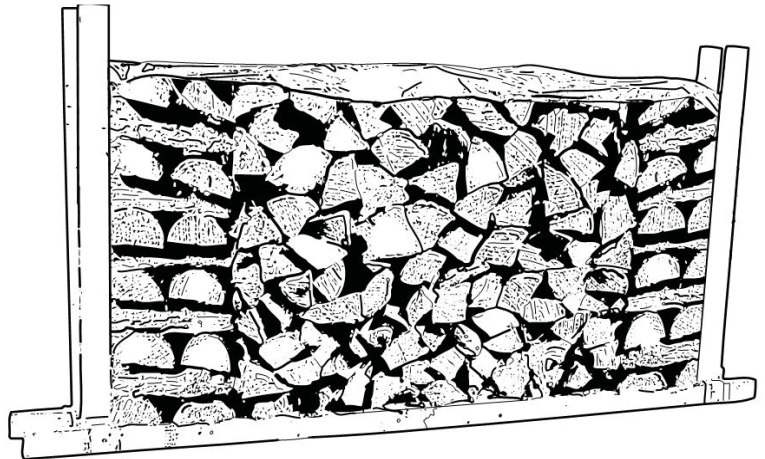

Use these guidelines to find out if the firewood is dry enough to burn:

- Cracks forms at the end of logs as they dry;
- The wood turns from white or cream colored to grey or yellow;
- Two pieces of wood struck together sounds hollow;
- Dry wood is much lighter in weight than wet wood,
- The face of a fresh cut feels warm and dry;
- The moisture content read by a moisture meter is between 15% to 20%.

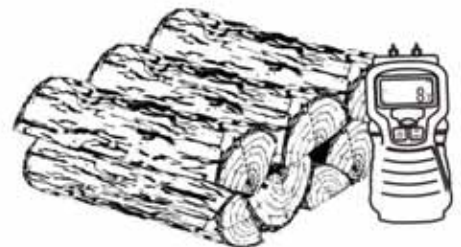

4. Operating the Stove



This wood heater has a manufacturer-set minimum low burn rate that must not be altered. It is against federal regulations to alter this setting or otherwise operate this wood heater in a manner inconsistent with operating instructions in this manual.

The installation of the following items is optional and should be completed before using the stove :

- Install the blower (see «[Appendix 3: Optional Blower Installation](#)»)
- Install the thermodisc (see «[Appendix 4: Optional Thermodisc Installation](#)»)
- Install the fresh air intake (see «[Appendix 1: Optional Fresh Air Intake Kit Installation](#)»)

4.1 The Use of a Fire Screen

This stove has been tested for use with an open door in conjunction with a fire screen, sold separately. The fire screen must be properly secured on the stove to avoid any risk of sparks damaging the flooring. When the fire screen is in use, do not leave the stove unattended to respond promptly in the event of smoke spillage into the room. Potential causes of smoke spillage are described in Section «[9. The Venting System](#)» of this manual. See «[Appendix 2: Optional Fire Screen Installation](#)» for installation instructions.

OPERATING THE STOVE WITH A FIRE SCREEN INCREASES POSSIBILITIES OF GENERATING CARBON MONOXIDE. CARBON MONOXIDE IS AN ODOURLESS GAS THAT IS HIGHLY TOXIC WHICH CAN CAUSE DEATH AT HIGH CONCENTRATION IN AIR. INSTALLATION OF A CARBON MONOXIDE DETECTOR IS HIGHLY RECOMMENDED.

4.2 Blower Operation

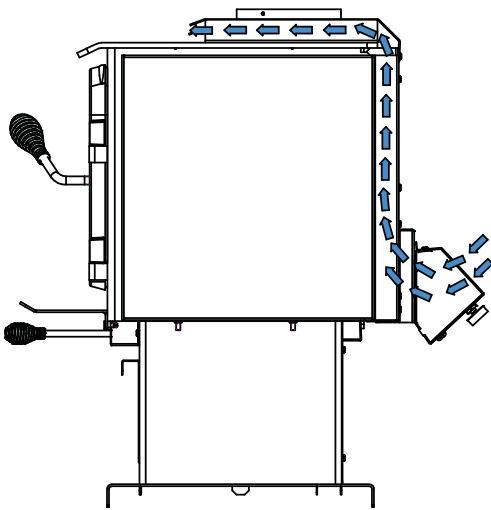

Figure 7: Airflow with a blower

It is possible to install a blower on this stove. The blower is optional and is sold separately. See «[Appendix 8: Exploded Diagram and Parts List](#)» for genuine part number.

The blower is installed on the back of the stove to increase the airflow through the heat exchanger and improve hot air circulation in the room. When used regularly, the blower can provide a small increase in efficiency, up to 2%. However, the use of a blower should not be used as a way to gain more output from a stove that is undersized for the space it is intended to heat.



Ensure the blower power cord is not in contact with any surface of the stove to prevent electrical shock or fire damage. Do not run the power cord underneath the stove.

The blower has a variable speed control that can be adjusted in three different positions; either from high (HI) to low (LO) or closed (OFF).

Allow the stove to reach operating temperature (approximately one hour) before turning on the blower, since increased airflow from the blower will remove heat and affect the start up combustion efficiency.

It is possible to add a heat sensor, sold separately, to the blower. When the blower is on (position between HI and LO), the heat sensor will make the blower start automatically when the stove is hot enough and will stop it when the stove has cooled down. Therefore, the blower speed control can be left at the desired setting.

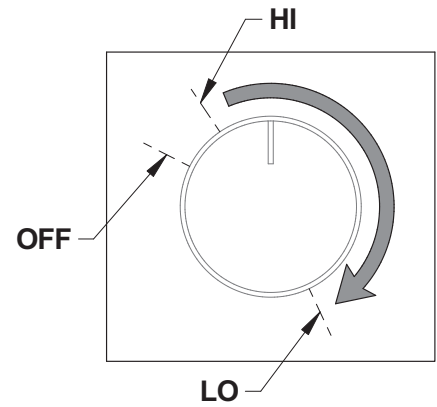

Figure 8: Variable speed control

5. Burning Wood Efficiently

5.1 First Use

Two things happen when burning the first few fires; the paint cures and the internal components are conditioned. As the paint cures, some of the chemicals vaporize. The vapors are not poisonous, but they smell bad. Fresh paint fumes can also trigger false alarms in smoke detectors. When lighting the heater for the first few times, it may be wise to open doors and windows to ventilate the house.

Burn two or three small fires to begin the curing and conditioning process. Then build bigger and hotter fires until there is no longer paint smell from the stove. As hotter and hotter fires are burned, more of the painted surfaces reach the curing temperature of the paint. The smell of curing paint does not disappear until one or two very hot fires have been burned.

5.2 Lighting Fires

Each person heating with wood develops its own favorite way to light fires. Regardless of the method chosen, the goal should be to have a hot fire burning, quickly. A fire that ignites fast produces less smoke and deposits less creosote in the chimney.



Never use gasoline, gasoline-type lantern fuel (naphtha), fuel oil, motor oil, kerosene, charcoal lighter fluid, or similar liquids or aerosols to start or ‘freshen up’ a fire in this wood stove. Keep all such liquids well away from the stove while it is in use.

Here are three popular and effective ways to ignite wood fires.

5.2.1 Conventional Method

The conventional method to build a wood fire is to crumple 5 to 10 sheets of newspaper and place them into the firebox and hold them in place with ten pieces of kindling wood. The kindling should be placed on and behind the newspaper.

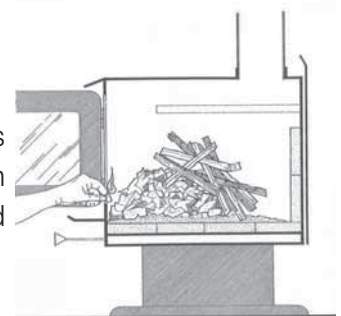

Then add two or three small pieces of firewood. Open the air intake control completely and ignite the newspaper. Leave the door slightly ajar. Once the fire has ignited, the door can be closed with the air control still fully open. When the kindling is almost completely burned, standard firewood pieces can be added.

Do not leave the heater unattended when the door is slightly open. Always close and latch the door after the fire ignites.

5.2.2 The Top Down Method

This method is the opposite of the conventional method and only works properly if well-seasoned wood is used.

Place three or four small, split, dry logs in the firebox. Arrange the kindling wood on the logs in two layers at right angles and place a dozen finely split kindling on the second row.

It is possible to use ragged paper but it may not hold in place since it tends to roll while it is burning. The best is to wrap a sheet on itself, grab the ends of the roll and make a knot. Use four or five sheets of paper tied together and put them on top and around the kindling. Open the air intake control completely, ignite the paper and close the door.

The top down fire method has two advantages over the traditional method: first, the fire does not collapse on itself, and it is not necessary to add wood gradually since the combustion chamber is full before the fire is lit.

5.2.3 Two Parallel Logs Method

Two spit logs are placed in the firebox with a few sheets of twisted newspapers in between the logs. Fine kindling is added across the two logs and some larger kindling across those, log cabin style. Newspaper is lit.

5.2.4 Using Fire Starters

Commercial fire starters can be used instead of a newspaper. Some of these starters are made of sawdust and wax and others are made of specialized flammable solid chemicals. Always follow the package directions when using. Gel starters can also be used, but only to light a fire, in a cold combustion chamber without hot embers inside.

5.3 Combustion Cycles

Wood heating with a space heater is very different than other forms of heating. There will be temperature variations in different parts of the house and there will be temperature variations throughout day and night. This is normal, and for experienced wood burners these are advantages of zone heating wood burning.

Wood heaters don't have a steady heat output. It is normal for the temperature to rise after a new load of wood is ignited and for its temperature to gradually decrease throughout the burning cycle. This increasing and decreasing temperature can be matched with the household routines. For example, the temperature in the area can be cooler when the household is active, and it can be warmer when it is inactive. Wood burns best in cycles. A cycle starts when a new load of wood is ignited by hot coals and ends when that load has been consumed down to a bed of charcoal about the same size as it was when the wood was loaded.

Trying to produce a steady heat output by placing a single log on the fire at regular intervals is not recommended. Always place at least three, and preferably more pieces on the fire at a time so that the heat radiated from one piece helps to ignite the pieces next to it. Each load of wood should provide several hours of heating. The size of each load may vary depending on the amount of heat required.

Burning in cycles means the loading door does not need to be opened while the wood is flaming. This is an advantage since it is preventing smoke leaking from the heater when the door is opened as a full fire is burning. This is especially true if the chimney is on the outside wall of the house.

If the door must be opened while the fire is flaming, fully open air control for a few minutes then open the door slowly.

5.4 Rekindling a Fire

When the temperature of the room is lower and all that remains is embers, it is time to reload. Remove excess ash from the front of the firebox and bring the ashes forward. Place a new load of wood on, and at the back of the embers. Open the air control completely and close the door.

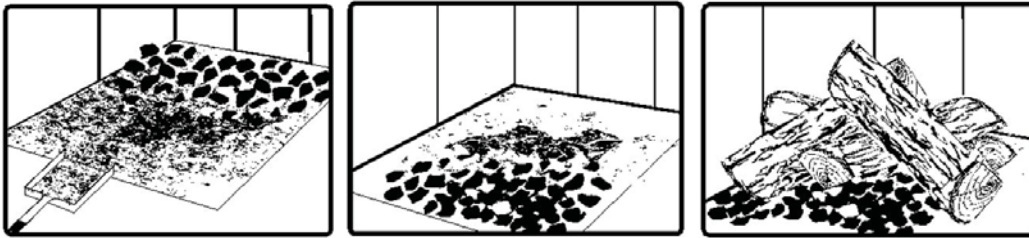

Raking the coals is useful for two reasons. First, it brings them near where most of the combustion air enters the firebox. This will ignite the new load quickly. Secondly, the charcoal will not be smothered by the new load of wood. When the embers are simply spread inside the combustion chamber, the new load smoulder for a long time before igniting.

Close the air control only when the firebox is full of bright turbulent flames, the wood is charred, and its edges are glowing.

The heater should not be left unattended during ignition and the fire should not burn at full intensity for more than a few minutes.

When lighting a new load, the appliance produces a heat surge. This heat surge is pleasant when the room temperature is cool but can be unpleasant when the room is already warm. Therefore, it is best to let each load of wood burn completely so that the room cools down before putting a load of wood back on.

5.5 Removing Ashes

Ash should be removed from the firebox every two to three days of full time heating. Ash should not accumulate excessively in the firebox since it will affect the proper operation of the appliance. The best time to remove ash is in the morning, after an overnight fire when the heater is relatively cold, but there is still a little chimney draft to draw the ash dust into the heater and prevent going out into the room.

Ashes almost always contain live embers that can stay hot for days and which release carbon monoxide gas. Ashes should be placed in a tightly covered metal container. The container must be placed on a non-combustible floor or on the ground well away from all combustible materials.

If the ashes are disposed of by burial in soil or otherwise locally dispersed, they should be kept in a closed metal container until they are completely cooled. No other waste should be placed in this container.



NEVER STORE ASHES INDOORS OR IN A NON-METALLIC CONTAINER OR ON A WOODEN DECK.

5.6 Air Intake Control

Once the firewood, firebox and chimney are hot, air intake can be reduced to achieve a steady burn.

As the air intake is reduced, the burn rate decreases. This has the effect of distributing the thermal energy of the fuel over a longer period of time. In addition, the flow rate of exhaust through the appliance and flue pipe slows down, which increases the duration of the energy transfer of the exhaust gases. As the air intake is reduced, the flame slows down.

If the flames diminish to the point of disappearing, the air intake has been reduced too early in the combustion cycle or the wood used is too wet. If the wood is dry and the air control is used properly, the flames should decrease, but remain bright and stable.

On the other hand, too much air can make the fire uncontrollable, creating very high temperatures in the unit as well as in the chimney and seriously damaging them. A reddish glow on the unit and on the chimney components indicates overheating. Excessive temperatures can cause a chimney fire.

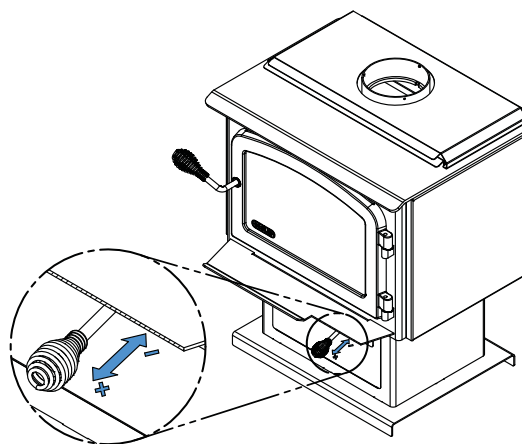

5.7 Fire Types

Using the air intake control is not the only way to match the appliance heat output to the desired temperature in the house. A house will need far less heating in October than in January to maintain a comfortable temperature. Filling the firebox full in fall weather will overheat the space. Otherwise, the combustion rate will have to be reduced to a minimum and the fire will be smoky and inefficient. Here are some suggestions for building fires suitable for different heating needs.

5.7.1 Flash Fire

To build a small fire that will produce a low heat output, use small pieces of firewood and load them crisscross in the firebox. The pieces should only be 3" (76 mm) to 4" (102 mm) in diameter. After raking the coals, lay two pieces parallel to each other diagonally in the firebox and lay two more across them in the other direction. Open the air control fully and only reduce the air after the wood is fully flaming. This kind of fire is good for mild weather and should provide enough heat for up to four hours. Small fires like this are a good time to use softer wood species and avoid overheating the house.

5.7.2 Long Lasting Fire

For a fire that will last up to eight hours but will not produce intense heat, use soft wood and place the logs compactly in the firebox. Before reducing the air intake, the load will have to burn at full heat for long enough for charring the surface of the logs. The flame must be bright before letting the fire burn by itself.

5.7.3 High Output Fires

When heating needs are high during cold weather, the fire should burn steadily and brightly. This is the time to use larger pieces of hardwood. Place the biggest pieces at the back of the firebox and place the rest of the pieces compactly. A densely built fire like this will produce the longest combustion this stove is capable of.

Special attention must be paid when building fires like this since if the air intake is reduced too quickly, the fire could smoulder. The wood must be flaming brightly before leaving the fire to burn.

5.7.4 Burn Cycle Time

The burn cycle time is the period between loading wood on a coal bed and the burning of that wood back to a coal bed of the same size. The flaming phase of the fire lasts for roughly the first half of the burn cycle and the second half is the coal bed phase during which there is little or no flame. The burning time expected from this stove, including both phases, will vary depending on a number of things, such as:

- firebox size,
- the amount of wood loaded,
- the species of the wood,
- the wood moisture content,
- the size of the space to be heated,
- the climate zone where the house is, and
- the time of the year.

The table below gives an approximate maximum burn cycle time, based on firebox volume.

Table 1 : Approximate Maximum Burn Cycle Time

FIREBOX VOLUME	MAXIMUM BURN CYCLE TIME
<1.5 cubic feet	3 to 5 hours
1.5 c.f. to 2.0 c.f.	5 to 6 hours
2.0 c.f. to 2.5 c.f.	6 to 8 hours
2.5 c.f. to 3.0 c.f.	8 to 9 hours
>3.0 c.f.	9 to 10 hours

A longer burning time is not necessarily an indication of efficient operation. It is preferable to build a smaller fire that will provide three or four hours of heating than to fully load the firebox for a much longer burn. Shorter burn cycles make it easier to match the heat output of the stove to heat demand for the space.

5.7.5 Logs Orientation

In a relatively square firebox, the wood can be loaded north-south (ends of the logs visible) or east-west (sides of the logs visible).

North-south loads allow more wood to be loaded at the same time. On the other hand, they break into smaller pieces faster. North-south loading is good for high output, long lasting fires for cold weather.

East-west loads allow a limited amount of wood since too many logs could cause them to fall on the glass. East-west loads, placed in a compact way, take a long time before breaking down. They are excellent for low-intensity, long-lasting fires in relatively mild weather.

5.7.6 Carbon Monoxide

When unburned logs remain in the firebox and the flame disappears, go outside and look at the chimney exit. If there is visible smoke, it means that there is still combustible to burn but that the fire lacks air to burn properly. In this situation, the CO rate will increase so it is important to react. Open the door slightly and move the log with a poker. Turn it over and create a passage for the air below, making a trench with the coal bed. Add small pieces of wood to restart the combustion.

6. Maintenance

This heater will give many years of reliable service if used and maintained properly. Internal components of the firebox such as firebricks or refractory panels, baffle and air tubes will wear over time. Defective parts should always be replaced with original parts.

To avoid premature deterioration, follow the lighting and reloading procedures in section [«5. Burning Wood Efficiently»](#) and also avoid letting the heater run with the air intake fully open for entire burn cycles.

6.1 Cleaning and Painting

Painted and plated surfaces can be wiped down with a soft, damp cloth. If the paint is scratched or damaged, it is possible to repaint the heater with a heat-resistant paint. **Do not clean or paint the appliance when it is hot.** Before painting, the surface should be sanded lightly with sandpaper and then wiped off to remove dust. Apply two thin layers of paint.

6.2 Refractory Materials and Baffle

Inspect the firebricks or the refractory panels and the baffle for damage periodically and replace anything that is broken.

Operation of the heater with a cracked or missing baffle may cause unsafe temperatures and hazardous conditions and will void the warranty.

6.3 Glass Door

6.3.1 Cleaning

Under normal conditions, the door glass should stay relatively clear. If the firewood is dry enough and the operating instructions in this manual are followed, a whitish, dusty deposit will form on the inner surface of the glass after a week or so of use. This is normal and can be easily removed when the heater is cold by wiping with a damp cloth or paper towel and then drying.

When the stove runs at a low combustion rate, light brown stains may form, especially in the lower corners of the glass. This indicates that the fire has been smoky and some of the smoke has condensed on the glass. It also indicates incomplete combustion of the wood, which also means more smoke emissions and faster formation of creosote in the chimney.

The deposits that form on the glass are the best indication of the fuel quality and success in properly using the stove. These stains can be cleaned with a special wood stove glass cleaner.

Do not use abrasive products to clean the glass.

The goal should be having a clear glass with no brown stains. If brown stains appear regularly on the glass, something about the fuel or the operating procedure needs to be changed.

When brown streaks are coming from the edge of the glass, it is time to replace the gasket around the glass. The glass gasket should be self-adhesive. Always replace the gasket with a genuine one.

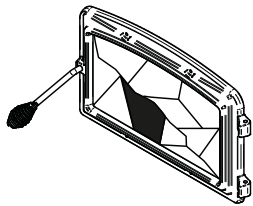

Do not clean the glass when the stove is hot.

Do not abuse the glass door by striking or slamming shut.

Do not use the stove if the glass is broken.

6.3.2 Replacement

The glass used is a ceramic glass, 5/32" (4 mm) thick, 15 3/4" x 9 3/4" (400 mm x 248 mm), tested to reach temperatures up to 1400°F. If the glass breaks, it must be replaced with one having the same specification.

To remove or replace the glass **(D)**:

1. Remove the door **(E)** from its hinges and lay it on a soft, flat surface.
2. Remove the eight screws **(A)**, the eight glass retainers **(B)**, and the metal frames **(C)**.
3. Remove the glass **(D)**. If it is damaged install a new one in place. The replacement glass must have a gasket all around.
4. Reinstall the glass, being careful to centre the glass in the door and not to over-tightening the retaining screw.

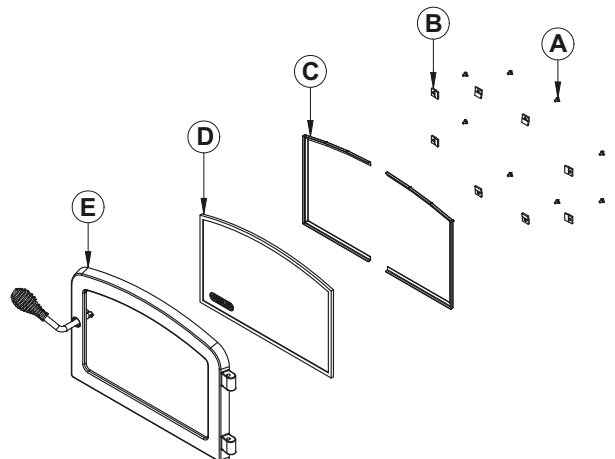

The two main causes of broken door glass are uneven placement in the door and over-tightening the retaining screws.

6.3.3 Gasket

The glass gasket is flat, adhesive-backed, woven fibreglass. The gasket must be centred on the edge of the glass.

1. Follow the steps of the previous section to remove the glass.
2. Remove the old gasket and clean the glass thoroughly.
3. Peel back a section of the paper covering the adhesive and place the gasket on a table with the adhesive side up.
4. Stick the end of the gasket to the middle of one edge, then press the edge of the glass down onto the gasket, taking care that it is perfectly centred on the gasket.
5. Peel off more of the backing and rotate the glass. The gasket must not be stretched during installation.
6. Cut the gasket to the required length.
7. Pinch the gasket onto the glass in a U shape, all around the glass.

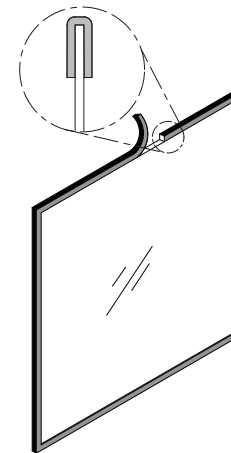

6.4 Door

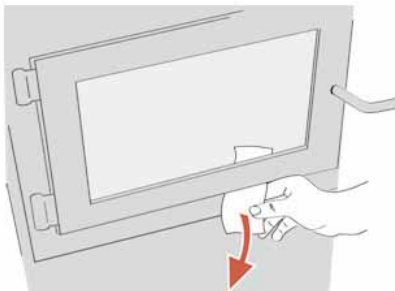

In order for the stove to burn at its best efficiency, the door must provide a perfect seal with the firebox. The tightness of the door seal can be verified by closing and latching the door on a strip of paper. The test must be performed all around the door. If the paper slips out easily anywhere, either adjust the door or replace the gasket.

6.4.1 Adjustment

The gasket seal may be improved with a simple latch mechanism adjustment:

1. Remove the split pin by pulling and turning it using pliers.
2. Turn the handle one counterclockwise turn to increase pressure.
3. Reinstall the split pin with a small hammer.

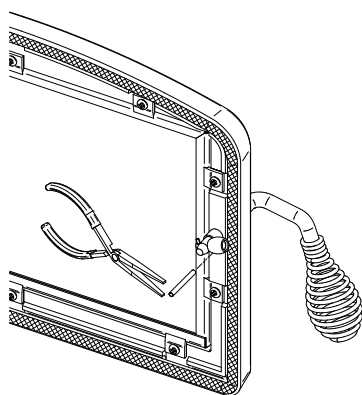

Figure 9: Removing the retaining pin

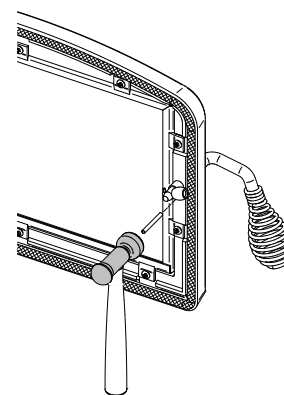
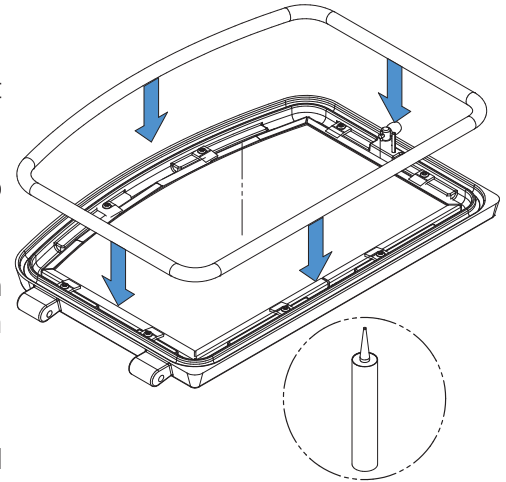

Figure 10: Reinstalling the retaining pin

6.4.2 Gasket

It is important to replace the gasket with another having the same diameter and density to maintain a good seal.

1. Remove the door and place it face-down on something soft like a cushion of rags or a piece of carpet.
2. Remove the old gasket from the door. Use a screwdriver to scrape the old gasket adhesive from the door gasket groove.
3. Apply a bead of approximately 3/16" (5 mm) of high temperature silicone in the door gasket groove. Starting from the middle, hinges side, press the gasket into the groove. The gasket must not be stretched during installation.
4. Leave about 1/2" (13 mm) long of the gasket when cutting and press the end into the groove. Tuck any loose fibers under the gasket and into the silicone.
5. Close the door. Do not use the stove for 24 hours.



6.5 Exhaust System

Wood smoke can condense inside the chimney, forming a flammable deposit called creosote. If creosote builds up in the system, it can ignite when a hot fire is burned in the stove. A very hot fire can progress to the top of the chimney. Severe chimney fires can damage even the best chimney. Smoldering, smoky fires can quickly cause a thick layer of creosote to form. When the stove is operated properly, the exhaust from the chimney is mostly clear and creosote builds up more slowly.

«Creosote - Formation and Need to Removal

When wood is burned slowly, it produces tar and other organic vapors, which combine with expelled moisture to form creosote. The creosote vapors condense in the relatively cooler chimney flue of a slow-burning fire. As a result, creosote residue accumulates on the flue lining. When ignited, this creosote makes an extremely hot fire.

The chimney connector and chimney should be inspected at least once every two months during the heating season to determine if a creosote buildup has occurred.

If a significant layer of creosote has accumulated (1/8" [3 mm] or more) it should be removed to reduce the risk of a chimney fire.»

6.5.1 Cleaning Frequency

It is not possible to predict how much or how quickly creosote will form in the chimney. It is important, therefore, to check the build-up in the chimney monthly until the rate of creosote formation is determined. Even if creosote forms slowly in the system, the chimney should be cleaned and inspected at least once each year.

Establish a routine for the fuel, wood burner and firing technique. Check daily for creosote build-up until experience shows how often you need to clean to be safe.

Be aware that the hotter the fire the less creosote is deposited, and weekly cleaning may be necessary in mild weather even though monthly cleaning may be enough in the coldest months.

Contact your local municipal or provincial fire authority for information on how to handle a chimney fire. Have a clearly understood plan to handle a chimney fire.

6.5.2 *Sweeping the Chimney*

Chimney sweeping can be a difficult and dangerous job. People with no chimney sweeping experience will often prefer to hire a professional chimney sweep to inspect and clean the system for the first time. After seeing the cleaning process, some will choose to do it themselves.

The chimney should be checked regularly for creosote build-up. Inspection and cleaning of the chimney can be facilitated by removing the baffle. See [«Appendix 6: Air Tubes and Baffle Installation»](#) for more details.



6.5.3 *Chimney Fire*

Regular chimney maintenance and inspection can prevent chimney fires. If you have a chimney fire, follow these steps:

1. Close the stove door and the air intake control;
2. Alert the occupants of the house of the possible danger;
3. If you require assistance, alert the fire department;
4. If possible, use a dry chemical fire extinguisher, baking soda or sand to control the fire. **Do not use water** as it may cause a **dangerous steam explosion**;

Do not use the appliance again until the stove and its chimney have been inspected by a qualified chimney sweep or a fire department inspector.

PART B - INSTALLATION

7. Safety Information and Standards

- The information given on the certification label affixed to the appliance always overrides the information published, in any other media (owner's manual, catalogues, flyers, magazines and web sites).
- Mixing of appliance components from different sources or modifying components may result in hazardous conditions. Where any such changes are planned, Stove Builder International Inc. Should be contacted in advance.
- Any modification of the appliance that has not been approved in writing by the testing authority violates CSA B365 (Canada), and ANSI NFPA 211 (USA).
- **DO NOT CONNECT TO OR USE IN CONJUNCTION WITH ANY AIR DISTRIBUTION DUCTWORK UNLESS SPECIFICALLY APPROVED FOR SUCH INSTALLATION.**
- **DO NOT CONNECT THIS UNIT TO A CHIMNEY FLUE SERVING ANOTHER APPLIANCE.**
- Connect this stove only to a listed factory-built chimney for use with solid fuel or to a lined masonry chimney conforming to national and local building codes.
- If required, a supply of combustion air shall be provided to the room.

ENGLISH

7.1 Mobile Home

- May be installed in a mobile home. The installation requires a fresh air kit, sold separately.
- **WARNING : DO NOT INSTALL IN THE SLEEPING ROOM.**
- **THE STOVE MUST BE ATTACHED TO THE STRUCTURE OF THE MOBILE HOME.**
- **CAUTION : THE STRUCTURAL INTEGRITY OF THE MOBILE HOME FLOOR, WALL, CEILING AND ROOF MUST BE MAINTAINED.**

7.2 Regulations Covering Stove Installation

When installed and operated as described in these instructions, this wood stove is suitable for use as a freestanding heater in residential installations.

In Canada, the CSA B365 Installation Code for Solid Fuel Burning Appliances and Equipment and the CSA C22.1 Canadian National Electrical Code are to be followed in the absence of local code requirements. In the USA, the ANSI NFPA 211 Standard for Chimneys, Fireplaces, Vents and Solid Fuel-Burning Appliances and the ANSI NFPA 70 National Electrical Code are to be followed in the absence of local code requirements.

This stove must be connected to a chimney complying with the requirements for Type HT chimneys in the Standard for Factory-Built Chimneys for Residential Type and Building Heating Appliances, UL 103 and ULC S629 or to a code-approved masonry chimney with a flue liner.

7.3 Location of the Certification Label

Since the information given on the certification label affixed to the appliance always overrides the information published, in any other media (owner's manual, catalogues, flyers, magazines and web sites) it is important to refer to it in order to have a safe and compliant installation. In addition, important information about the stove can be found (model, serial number, etc.). The certification label is located on the back of the stove.

It is recommended to note the stove serial number on page 5 of this manual since it will be needed to precisely identify the version of the appliance in the event replacement parts or technical assistance is required.

8. Clearances to Combustible Material

The clearances shown in this section have been determined by tests according to procedures set out in safety standards ULC S627 (Canada), UL 1482 (U.S.A.) and UL 737 (U.S.A.). When the stove is installed so that its surfaces are at or beyond the minimum clearances specified, combustible surfaces will not overheat under normal and even abnormal operating conditions.

No part of the stove or flue pipe may be located closer to combustibles than the minimum clearance figures given.

The clearances to combustible walls may be slightly different between Canada and the U.S.A. and may also vary depending on the use of single or double wall flue pipe. The proper clearances should be used depending on the stove location and type of flue pipe.

The clearances of the appliance and the flue pipes must be met individually, meaning the appliance cannot be installed closer to the combustible materials than the single or double wall pipe allows. For a safe way to reduce clearances refer to section [«8.3 Reducing Clearances Safely»](#)

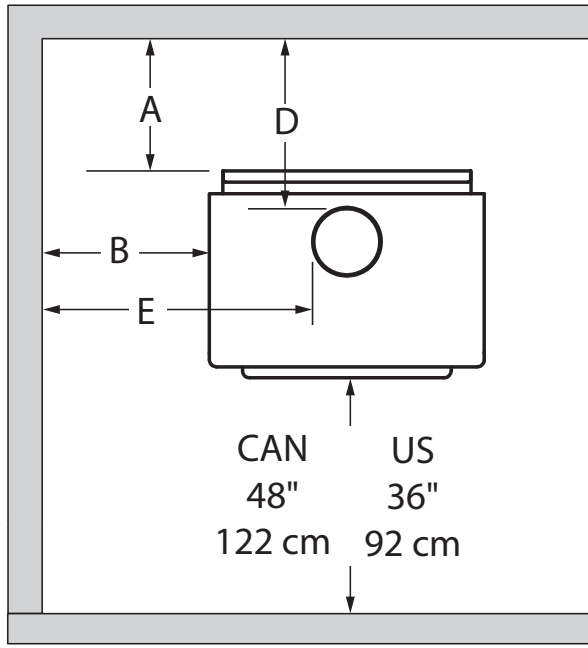

Figure 11: Clearances - Top

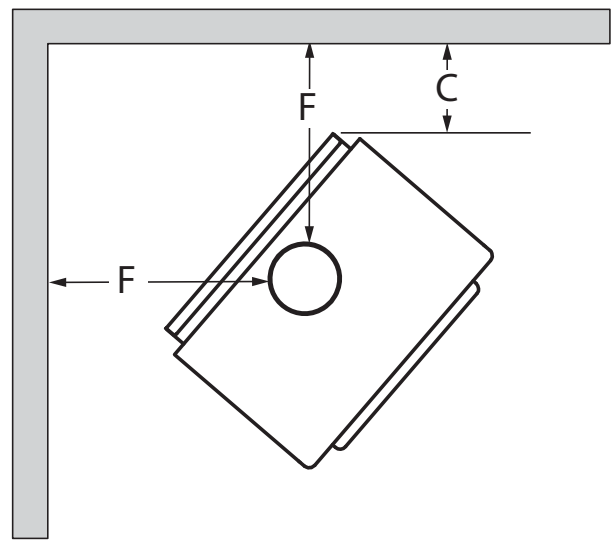

Figure 12: Clearances - Corner

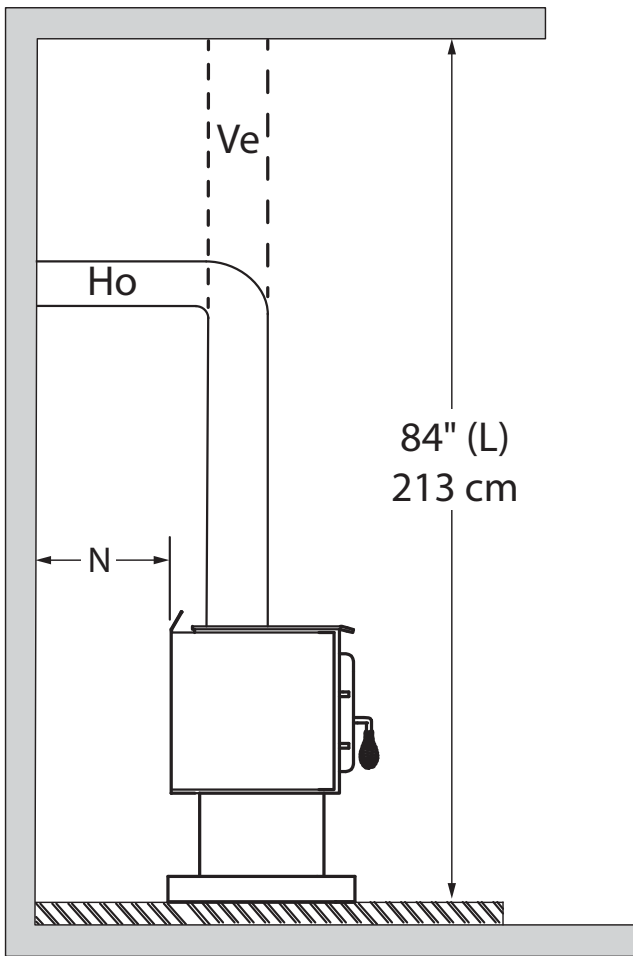

Figure 13: Clearances - Side

8.1 Clearances

	APPLIANCE CLEARANCES WITH SINGLE WALL PIPE CONNECTOR	
	Canada	USA
A	14 ½" (368 mm)	13" (330 mm)
B	10" (254 mm)	10" (254 mm)
C	12" (305 mm)	12" (305 mm)

	APPLIANCE CLEARANCES WITH DOUBLE WALL PIPE CONNECTOR	
	Canada	USA
A	6" (152 mm)	6" (152 mm)
B	10" (254 mm)	10" (254 mm)
C	6" (152 mm)	6" (152 mm)

If the above clearances are met, then the distances measured from the flue outlet will be:

	DISTANCES ¹³ FROM PIPE CONNECTOR WITH SINGLE WALL PIPE CONNECTOR	
	Canada	USA
D	18" (457 mm)	16 ½" (419 mm)
E	19" (483 mm)	19" (483 mm)
F	20 ¾" (527 mm)	20 ¾" (527 mm)

	DISTANCES ¹³ FROM PIPE CONNECTOR WITH DOUBLE WALL PIPE CONNECTOR	
	Canada	USA
D	9 ½" (241 mm)	9 ½" (241 mm)
E	19" (483 mm)	19" (483 mm)
F	14 ¾" (375 mm)	14 ¾" (375 mm)

8.1.1 With Heat Shield AC02710¹⁴

	APPLIANCE CLEARANCES WITH DOUBLE WALL PIPE CONNECTOR	
	Canada	USA
A	2 ½" (64 mm)	2 ½" (64 mm)
B	2 ½" (64 mm)	2 ½" (64 mm)
C	2 ½" (64 mm)	2 ½" (64 mm)

	DISTANCES ¹³ FROM DOUBLE WALL PIPE CONNECTOR	
	Canada	USA
D	6" (152 mm)	6" (152 mm)
E	11 ½" (292 mm)	11 ½" (292 mm)
F	11 ¼" (286 mm)	11 ¼" (286 mm)

¹³ The pipe distances listed in this table refer to the distances obtained when the stove is installed in accordance with the appliance clearances above mentioned.

¹⁴ Note that to reduce the clearances of an appliance using a single wall pipe connector, the use of a heat shield certified with the single wall pipe connector to be used as close as 6" (153 mm) from combustible materials must be used. Only in this case, the same clearances as a certified double wall pipe connector can be used.

8.1.2 With Lowered Ceiling

	APPLIANCE CLEARANCES WITH SINGLE WALL PIPE CONNECTOR	
	Canada	USA
A	14 ½" (368 mm)	14 ½" (368 mm)
B	12" (305 mm)	12" (305 mm)
C	13" (330 mm)	13" (330 mm)
L	78" (1981 mm)	78" (1981 mm)

	APPLIANCE CLEARANCES WITH DOUBLE WALL PIPE CONNECTOR	
	Canada	USA
A	9 ½" (241 mm)	9 ½" (241 mm)
B	12" (305 mm)	12" (305 mm)
C	13" (330 mm)	13" (330 mm)
L	78" (1981 mm)	78" (1981 mm)

If the above clearances are met, then the distances measured from the flue outlet will be:

	DISTANCES ¹⁵ FROM PIPE CONNECTOR WITH SINGLE WALL PIPE CONNECTOR	
	Canada	USA
D	18" (457 mm)	18" (457 mm)
E	21" (533 mm)	21" (533 mm)
F	21 ¾" (552 mm)	21 ¾" (552 mm)

	DISTANCES ¹⁵ FROM PIPE CONNECTOR WITH DOUBLE WALL PIPE CONNECTOR	
	Canada	USA
D	13" (330 mm)	13" (330 mm)
E	21" (533 mm)	21" (533 mm)
F	21 ¾" (552 mm)	21 ¾" (552 mm)

8.1.3 With Heat Shield AC02710 and Lowered Ceiling¹⁶

	APPLIANCE CLEARANCES WITH DOUBLE WALL PIPE CONNECTOR	
	Canada	USA
A	2 ½" (64 mm)	2 ½" (64 mm)
B	2 ½" (64 mm)	2 ½" (64 mm)
C	2 ½" (64 mm)	2 ½" (64 mm)
L	78" (1981 mm)	78" (1981 mm)

	DISTANCES FROM PIPE CONNECTOR WITH DOUBLE WALL PIPE CONNECTOR	
	Canada	USA
D	6" (152 mm)	6" (152 mm)
E	11 ½" (292 mm)	11 ½" (292 mm)
F	11 ¼" (286 mm)	11 ¼" (286 mm)

¹⁵ The pipe distances listed in this table refer to the distances obtained when the stove is installed in accordance with the appliance clearances above mentioned.

¹⁶ To reduce the clearances of an appliance using a single wall pipe connector, the use of a heat shield certified with the single wall pipe connector to be used as close as 6" (153 mm) from combustible materials must be used. Only in this case, the same clearances as a certified double wall pipe connector can be used.

8.1.4 Inside an Alcove

	APPLIANCE CLEARANCES WITH DOUBLE WALL PIPE CONNECTOR	
	Canada	USA
A	12 ½" (318 mm)	12 ½" (318 mm)
B	16" (406 mm)	16" (406 mm)
K	48" (1219 mm)	36" (914 mm)
L	78" (1981 mm)	78" (1981 mm)

	DISTANCES ¹⁷ FROM PIPE CONNECTOR WITH DOUBLE WALL PIPE CONNECTOR	
	Canada	USA
D	16" (406 mm)	16" (406 mm)
E	25" (635 mm)	25" (635 mm)

8.1.5 Mobile Home

It is strictly **forbidden** to install a unit with **a single wall pipe** in a **mobile home**.

	APPLIANCE CLEARANCES WITH DOUBLE WALL PIPE CONNECTOR	
	Canada	USA
A	8" (203 mm)	8" (203 mm)
B	14 ½" (368 mm)	14 ½" (368 mm)
C	12" (305 mm)	12" (305 mm)

	DISTANCES ¹⁷ FROM PIPE CONNECTOR WITH DOUBLE WALL PIPE CONNECTOR	
	Canada	USA
D	11 ½" (292 mm)	11 ½" (292 mm)
E	23 ½" (597 mm)	23 ½" (597 mm)
F	20 ¾" (527 mm)	20 ¾" (527 mm)

8.1.6 Mobile Home With Heat Shield AC02710

It is strictly **forbidden** to install a unit with **a single wall pipe** in a **mobile home**.

	APPLIANCE CLEARANCES WITH DOUBLE WALL PIPE CONNECTOR	
	Canada	USA
A	3" (76 mm)	3" (76 mm)
B	5" (127 mm)	5" (127 mm)
C	3" (76 mm)	3" (76 mm)

	DISTANCES ¹⁷ FROM PIPE CONNECTOR WITH DOUBLE WALL PIPE CONNECTOR	
	Canada	USA
D	6 ½" (165 mm)	6 ½" (165 mm)
E	14" (356 mm)	14" (356 mm)
F	11 ¾" (298 mm)	11 ¾" (298 mm)

¹⁷ The pipe distances listed in this table refer to the distances obtained when the stove is installed in accordance with the appliance clearances above mentioned.

8.2 Floor Protection

This stove is designed to prevent the floor from overheating. However, it must be placed on a nonflammable surface to protect the floor from hot embers that may fall during loading.

The floor protection must be a continuous, non combustible material, such as steel with a minimum thickness of 0.015" (0.38 mm) or ceramic tiles sealed together with grout. Cement board, brick, or any other approved or listed material suited for floor protection. No R factor required.

Any type of tile will require a continuous non combustible sheet beneath to prevent the possibility of embers falling through to the combustible floor if cracks or separation should occur in the finished surface. Check local codes for approved alternatives.

No protection is required if the unit is installed on a non-combustible floor (ex: concrete).

	FLOOR PROTECTION	
	Canada	USA
G¹⁸	8" (203 mm)	N/A
H	8" (203 mm)	N/A
I	18" (457 mm) From door opening	16" (203 mm) From door opening
J	N/A	8" (203 mm)
N¹⁹	N/A	See Note 2

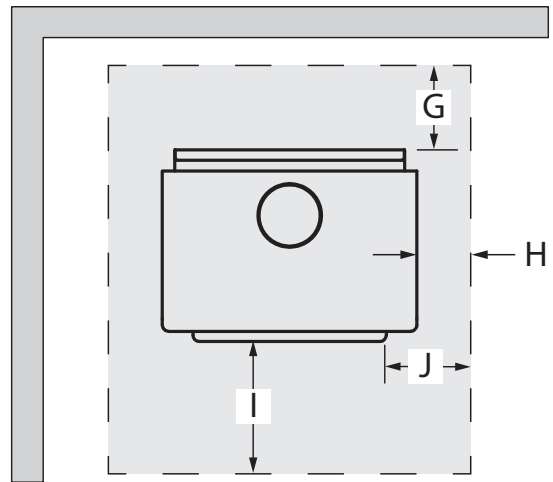

Figure 14: Floor Protection

8.3 Reducing Clearances Safely

It is often desired to use as little space as possible when installing a wood stove. To do this, it is possible to reduce the clearances safely and install the stove closer to the walls by permanently installing a heat shield between the stove and the flammable material.

The rules for heat shields are sometimes complicated. Read and apply the instructions carefully. Some regions may have different regulations. Consult the local building code or contact the fire department for restrictions, inspection and installation requirements in the area.

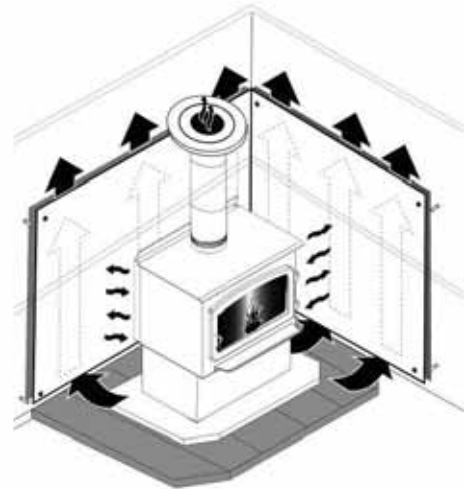
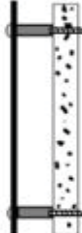
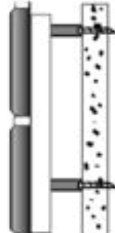





Figure 15: Heat shield

¹⁸ The floor protection at the back of the stove is limited to the stove's required clearance if such clearance is smaller than 8 inches (203 mm).

¹⁹ Only required under the horizontal section (Ho) of the connector. Must exceed each side of the connector by at least 2 inches (51 mm). See «Figure 13: Clearances - Side»

TYPE OF SHIELD	CLEARANCES MAY BE REDUCED BY THESE PERCENTAGES				
	SIDES AND REAR		TOP (CEILING)		
	CAN / USA (%)	USA MIN.	CAN / USA (%)	USA MIN.	
Sheet metal, a minimum of 24 gauge (0.61 mm) in thickness , spaced out at least 1" (25 mm)* by non-combustible spacers	67	12" (305 mm)	50	18" (457 mm)	
Ceramic tiles, or equivalent non-combustible material, on non-combustible board spaced out at least 1" (25 mm)* by non-combustible spacers	50	18" (457 mm)	33	24" (610 mm)	
Ceramic tiles, or equivalent non-combustible material, on non-combustible board, with a minimum of 24 gauge (0.61 mm) sheet metal backing spaced out at least 1" (25 mm)* by non-combustible spacers	67	12" (305 mm)	50	24" (610 mm)	
Brick, spaced out at least 1" (25 mm)* by non-combustible spacers	50	18" (457 mm)	N/A	N/A	
Brick, with a minimum of 24 gauge (0.61 mm) sheet metal backing, spaced out at least 1" (25 mm)* by non-combustible spacers	67	12" (305 mm)	N/A	N/A	

* In Canada this space can be 7/8" (21 mm).

8.3.2 Shield Construction Rules

- Adhesives used in shield construction must not ignite or lose its adhesive qualities at temperatures likely to be encountered.
- Mounting hardware which extends from the shield surface into combustibles may be used only at the edges of the shield.
- Mounting hardware must allow full vertical ventilation.

See figures on next page for shield construction to match each letter to a clearance.

- A) Minimum clearance between the appliance top and an unshielded combustible ceiling: (49 ¾") (1245 mm) .
- B) Shield extension above the appliance: 20" (500 mm).
- C) Minimum space behind the shield: 1" (25 mm). In Canada 7/8" (21 mm).
- D) Clearance along the bottom of the shield: minimum 1" (25 mm) and maximum 3" (75 mm).
- E) Minimum clearance along the top of the shield at the ceiling: 3" (75 mm).
- F) Mounting hardware must not be located closer than 8" (200 mm) from the vertical centre line of the appliance.
- G) Edge clearance for ceiling shields to side and back walls: 3" (75 mm).
- H) Shield extension beyond each side of the appliance: 18" (450 mm).

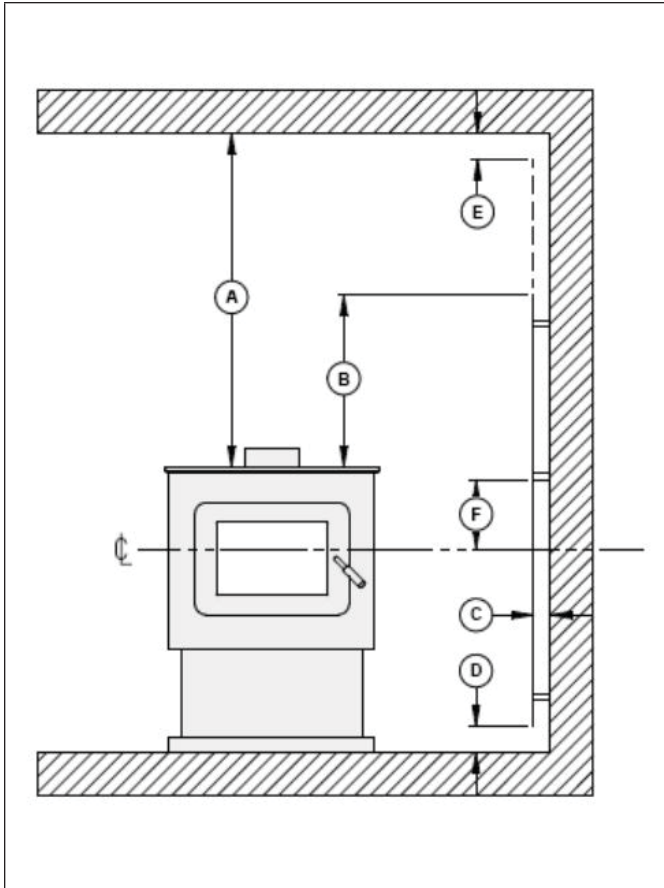

Figure 16: Heat shield clearances

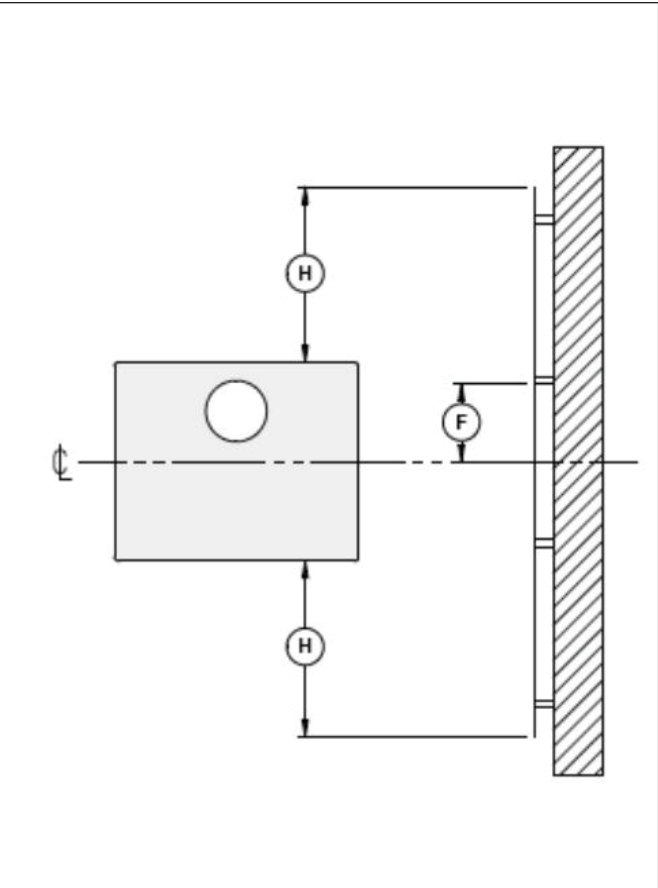

Figure 17: Heat shield clearances

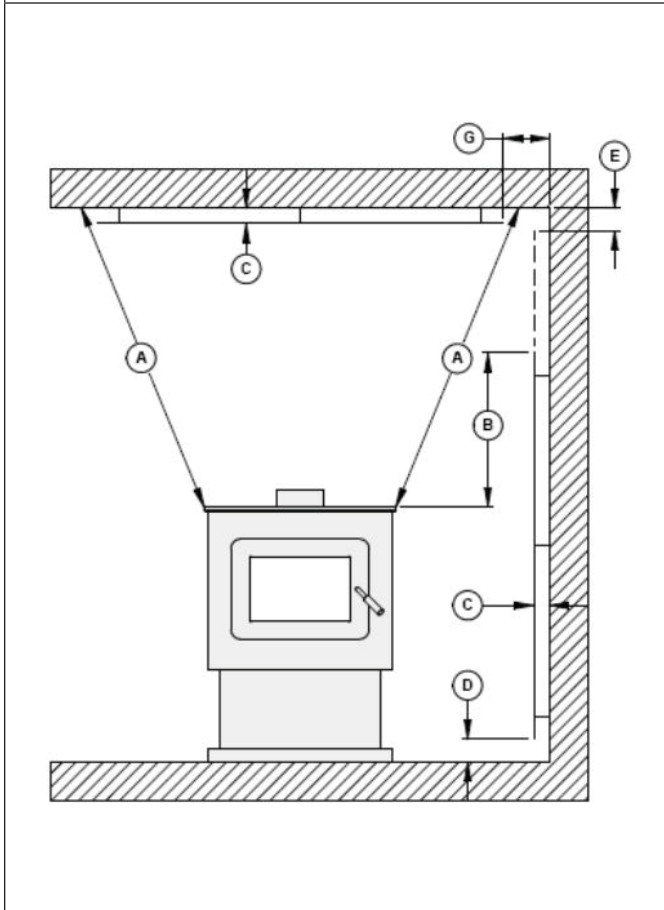

Figure 18: Heat shield clearances

9. The Venting System

9.1 General

The venting system, made of the chimney and the connecting pipe between the stove and the chimney, acts as the engine that drives the wood heating system. Even the best stove will not function safely and efficiently if it is not connected to a suitable chimney.

The heat in the flue gases that pass from the stove and chimney connector into the chimney is not waste heat. This heat is what the chimney uses to make the draft that draws in combustion air, keeps smoke inside the stove and safely vents exhaust to outside. The heat in the flue gas can be seen as the fuel the chimney uses to create draft.

9.2 Suitable Chimneys

This stove will provide optimum efficiency and performance when connected to a 6" diameter chimney flue system. The connection to a chimney having a diameter of at least 5" (Canada only) or no more than 7" is permitted, if it allows the proper venting of combustion gases and that such application is verified and authorized by a qualified installer. Otherwise, the diameter of the flue should be 6".

To be suitable, a factory-built metal chimney must comply with UL 103 HT (U.S.A.) or ULC S629 (Canada).

9.2.1 Factory-Built Metal Chimneys

These are sometimes referred to as 'high temp' chimneys because they have the specific characteristics to withstand temperatures that can be created by wood burning stoves. Factory-built chimneys are tested as a system with all the necessary components for installation. The instructions provided with the chimney by its manufacturer are the only reliable source of installation guidelines. To be safe and effective, the chimney must be installed exactly in accordance with the manufacturer's instructions. Only components intended for the brand and model of chimney should be used. Never fabricate or substitute parts from other chimney brands. The chimney must be a type suitable for solid fuel.

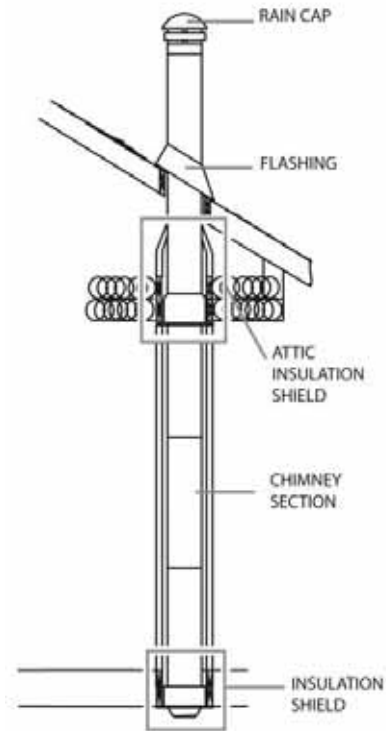

9.2.2 Factory-Built Metal Chimneys in Mobile Homes

For use in a mobile home, this stove is to be connected to a 6" double wall factory built chimney pipe conforming to ULC-S629 or UL 103HT standards for 650°C Factory-built chimney. The total length of the flue system should be at least 12 feet including elbows, from the top of the stove.

To maintain an effective vapour barrier, insulation and waterproof at the chimney and outside flue pipe, a roof flashing must be installed and sealed with silicone adhesive.

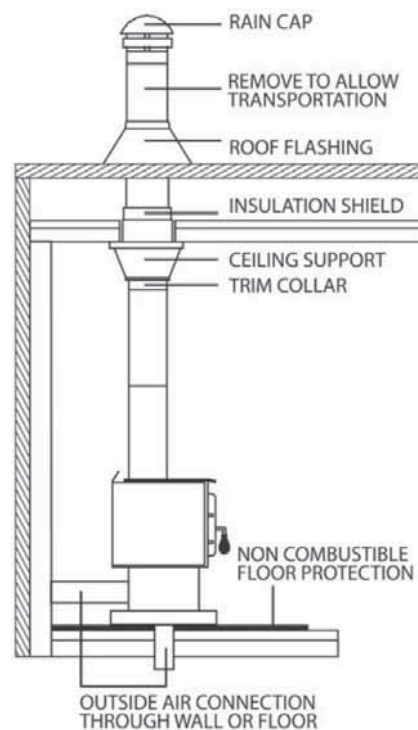

9.2.3 Masonry Chimneys

The stove may also be connected to a masonry chimney, provided the chimney complies with the construction rules found in the building code enforced locally. The chimney must have either a clay liner or a suitably listed stainless steel liner. If the masonry chimney has a square or rectangular liner that is larger in cross-sectional area than a round 6" flue, it should be relined with a suitably listed 6" stainless steel liner. Do not downsize the flue to less than 6" unless the venting system is straight and exceeds 25 feet in height. When passing through a combustible wall, the use of an insulated listed thimble is required.

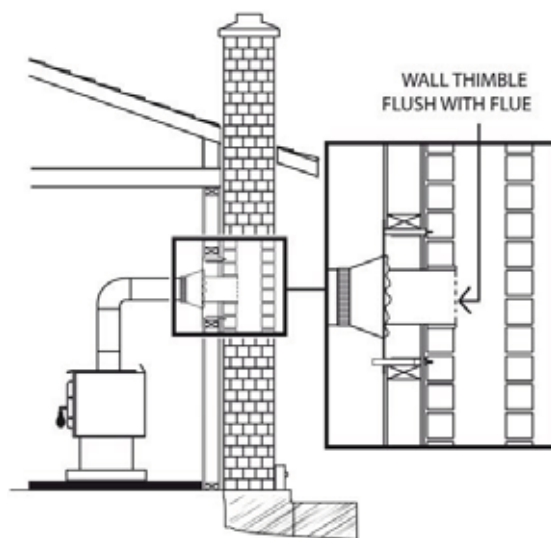

9.3 Minimum Chimney Height

The top of the chimney should be tall enough to be above the air turbulence caused when wind blows against the house and its roof. The chimney must extend at least 3 ft. (1 m) above the highest point of contact with the roof, and at least 2 ft. (60 cm) higher than any roof line or obstacle within a horizontal distance of 10 ft. (3 m).

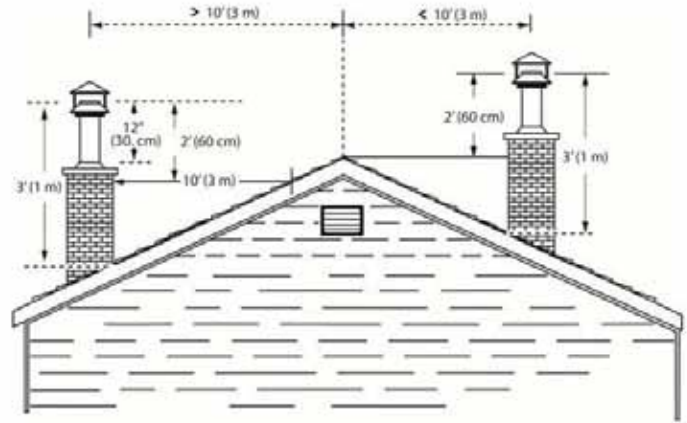

9.4 Chimney Location

Because the venting system is the engine that drives the wood heating system, it must have the right characteristics. The signs of bad system design are cold back drafting when there is no fire in the stove, slow kindling of new fires, and smoke roll-out when the door is opened for loading. There are two guidelines to follow. First, the chimney should be installed up through the heated space of the house, not out and up an outside wall. Second, the chimney should penetrate to the top of the building at or near the highest heated space.

Venting systems that rise straight up from the stove flue collar provide the best performance. Chimneys that rise inside the warm space of the house tend to provide a small amount of draft even when there is no fire burning. This means that when a fire is lit, the smoke goes up the chimney and strong draft build quickly as the chimney flue warms up. Chimneys that exit a house wall and run up outside can cause problems.

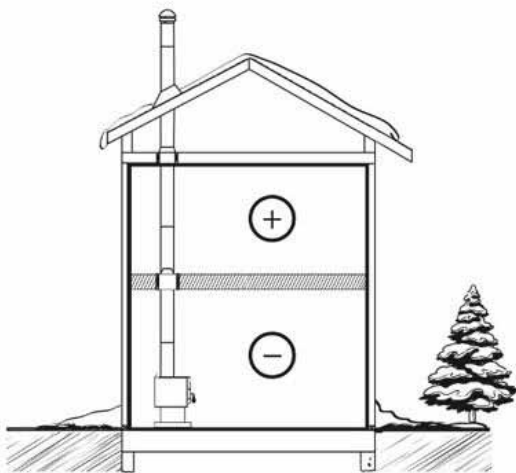

Figure 19: Good System Design

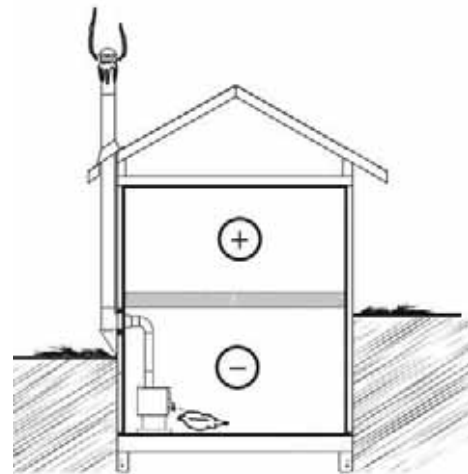

Figure 20: Inferior System Design

When it is cold outside, the warm air in the house is buoyant so it tends to rise. This creates a slight pressure difference in the house. Called 'stack effect', it produces a slightly negative pressure in the lower part of the house (compared to the outside) and a slightly positive pressure zone in the high part of the house.

If there is no fire burning in a heater connected to a chimney that is shorter than the warm space inside the house, the slight negative pressure in the lower part of the house will compete against the desired upward flow in the chimney. This occurs for the two following reasons:

First, the chimney runs up the outside of the house, so the air in it is colder and denser than the warm air in the house. And second, the chimney is shorter than the heated space of the house, meaning the negative pressure in the lower part of the house will draw cold air down the chimney, through the stove and into the room. Even the finest stove will not work well when connected to this chimney.

9.5 Supply of Combustion Air

9.5.1 Mobile Home

This stove is 'mobile home approved'. It must therefore have a supply of combustion air from outdoors. The air intake must not draw air from the attic, from the basement, from a garage or any enclosed space. Air must be drawn from a ventilated crawl space under the floor or directly from outside. Install a flexible or rigid, insulated pipe (HVAC type, must comply to ULC S110 and/or UL 181, Class 0 or Class 1) to the fresh air intake. Where a mobile home has been converted to a standard house by mounting it on a permanent basement foundation, the supply of outdoor air is not required.

9.5.2 Conventional House

The safest and most reliable supply of combustion air for a wood stove is from the room in which it is installed. Room air is already preheated so it will not chill the fire, and its availability is not affected by wind pressures on the house. Contrary to commonly expressed concerns, almost all tightly sealed new houses have enough natural leakage to provide the small amount of air needed by the stove. The only case in which the wood stove may not have adequate access to combustion air is if the operation of a powerful exhaust device (such as a kitchen range exhaust) causes the pressure in the house to become negative relative to outdoors.

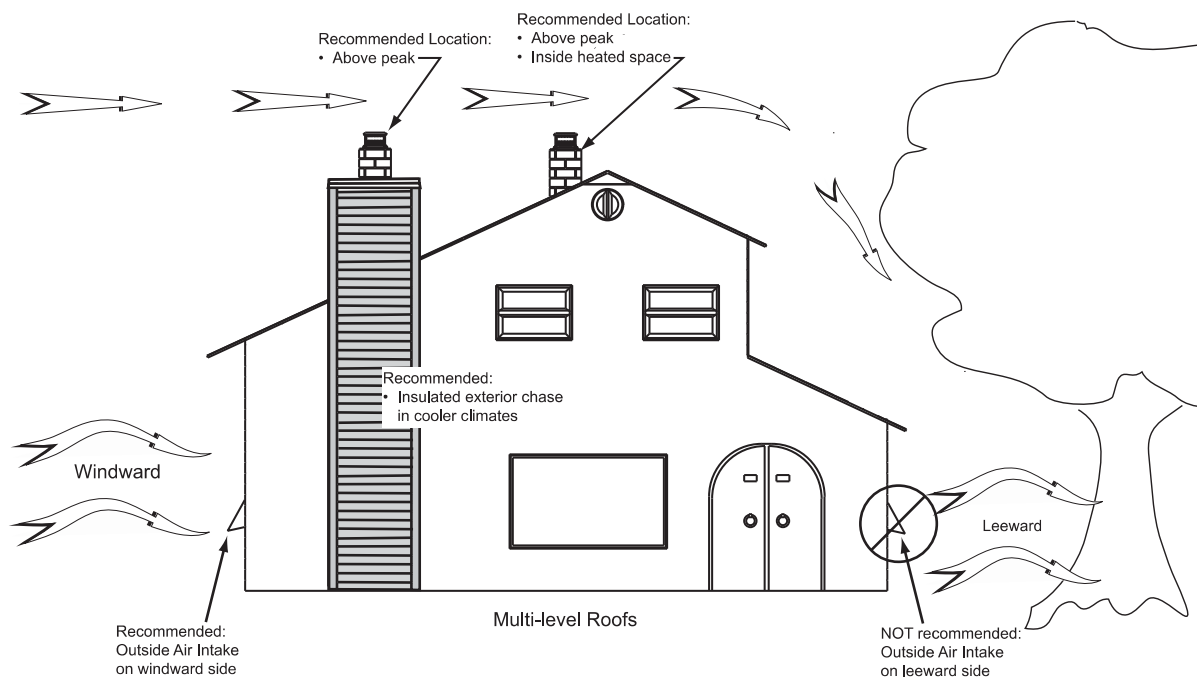

Figure 21: Air supply in conventional houses

If an air intake is installed through the wall of the house, its pressure can vary during windy weather. If there are changes in wood stove performance in windy weather, and in particular if smoke puffs from the stove, the air duct should be disconnected from the stove to determine if it is the cause of the problem. In some windy conditions, negative pressure at the duct weather hood outside the house wall may draw hot exhaust gases from the stove backwards through the duct to outdoors. Check the outdoor air duct for soot deposits when the full system is cleaned and inspected at least once each year.

9.6 Installing the Chimney Connector

The chimney connector is the single or double wall pipe installed between the stove flue collar and the chimney breech. Single wall pipe components are available from most hardware and building supply stores. These components are not usually tested to a particular standard and certified as compliant. Therefore, a list of rules found in solid fuel installation codes apply to the installation of a single wall pipe.

Double wall chimney connectors are tested and certified. The rules for double wall pipe are found in the manufacturer's installation instructions. These rules will be very different than those for single wall.

9.6.1 Installation of Single Wall Chimney Connector

The chimney connector assembly has been called 'the weak link' in the safety of wood heating systems because failure to install the connector properly (which has been common in the past) can result in house fires.

The best flue pipe assembly is one that rises straight up from the stove to the base of the chimney with no elbows. Straight assemblies are less likely to cause problems like smoke roll-out when the door is opened for loading. They are also more stable and easier to maintain than assemblies with elbows. Horizontal runs of flue pipe should be avoided where possible because they reduce chimney draft.

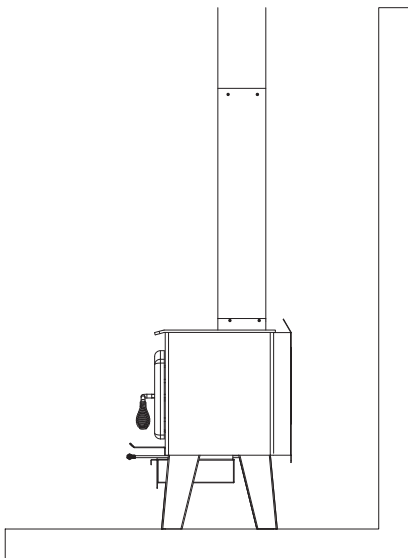

Figure 22: Best

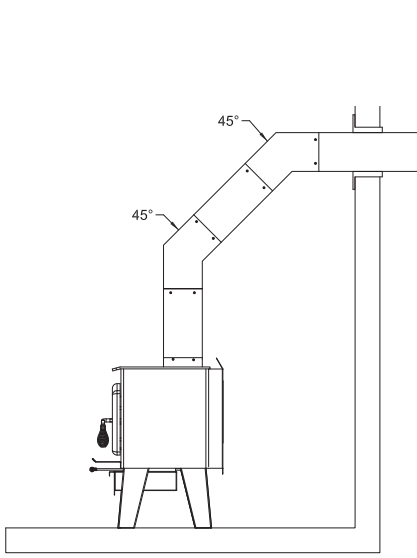

Figure 23: Acceptable

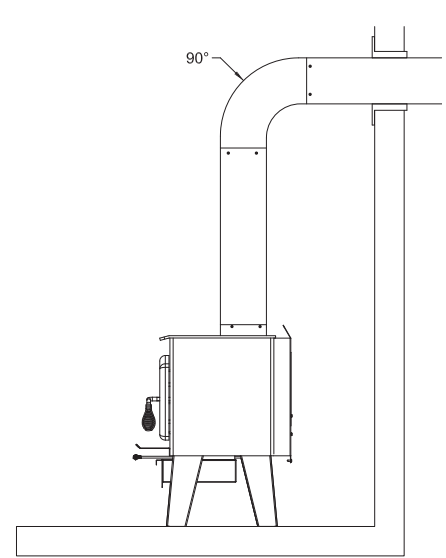

Figure 24: Avoid

The rules below are based on those found in the CSA B365 installation code. Please carefully follow these installation instruction rules, or those enforced by the local code.

- Maximum overall length of horizontal pipe: 10 ft. (3 m) including elbows.
- Minimum clearance from combustible material: 18" (450 mm). The minimum clearance may be reduced by 50 percent to 9" (225 mm) if suitable shielding is installed either on the pipe or on the combustible surface.
- The assembly should be as short and direct as possible between the stove and chimney. The use of two 45 degree elbows is often preferable to a single 90 degree elbow because less turbulence is created in the exhaust flow and they result in less horizontal run.
- The minimum overall height of the chimney system, measured from the stove top to the exterior termination cap of the chimney should be at least 12 ft. (3.66 m). A chimney which is too short may lack the "tunnel effect" required to obtain a proper draft.
- Maximum number of 90-degree elbows: 2.
- Maximum unsupported horizontal length: 3 ft. (1 m).
- Galvanized flue pipes must not be used because the coatings vaporize at high temperatures and release dangerous gases. Use black painted flue pipes.
- Flue pipes must be at least 24 gauge in thickness.
- Flue pipe joints should overlap 1 ¼" (30 mm).
- Each joint in the assembly must be fastened with at least three screws.
- The assembly must make allowance for expansion: elbows in assemblies allow for expansion; straight assemblies should include an inspection wrap with one end unfastened, or a telescopic section.
- Minimum upward slope towards the chimney: ¼ in/ft. (20 mm/m).
- One end of the assembly must be securely fastened to the flue collar with 3 sheet metal screws and the other end securely fastened to the chimney.
- There must be provision for cleaning of the pipes, either through a clean out or by removal of the pipe assembly. Removal of the assembly should not require that the stove be moved.
- The male ends of the sections must be oriented towards the appliance so that falling dust and condensation stay inside the pipe.
- A flue pipe must never pass through a combustible floor or ceiling or through an attic, roof space, closet or concealed space. Where passage through a wall or partition of combustible construction is desired, the installation shall conform to CAN/CSA-B365, Installation Code for Solid-Fuel-Burning Appliances and Equipment.
- A straight up connector assembly needs either a telescopic length or an inspection wrap (pipe coupler) to allow it to be assembled and disassembled without moving the stove.
- A straight flue pipe assembly offers the least restriction to gas flow and results in a stronger draft. Straight assemblies also need less maintenance because there are no corners to collect creosote.
- The chimney connector must be clean and in good condition.

APPENDIX 1: OPTIONAL FRESH AIR INTAKE KIT INSTALLATION



The configuration of this appliance do not allow the air intake to be installed underneath the pedestal. It can only be installed on the back.

ENGLISH

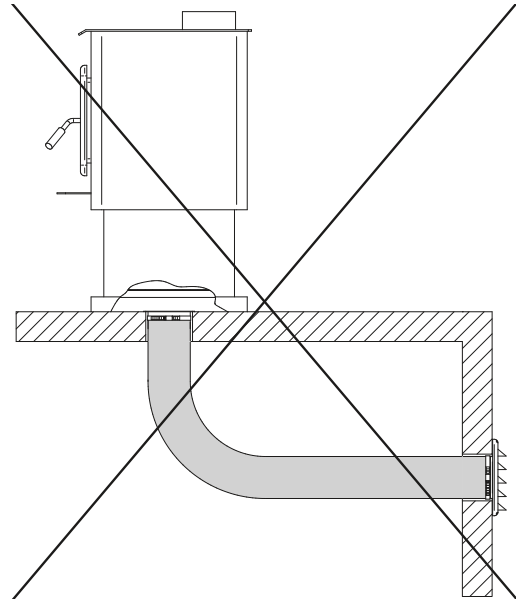
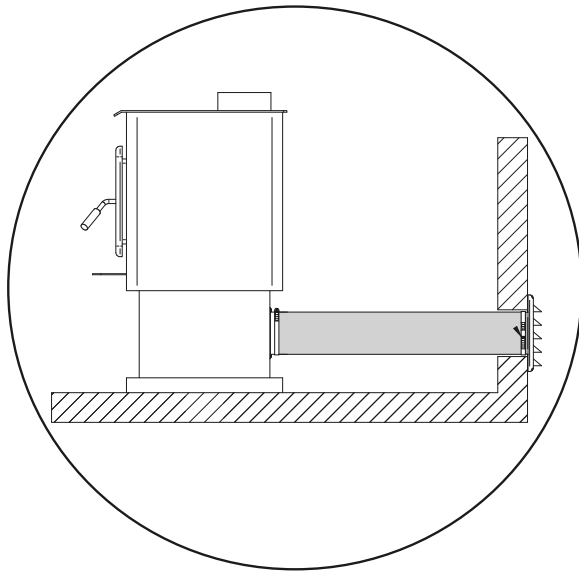

This mobile home approved stove requires the installation of a fresh air intake kit **(A)** and an insulated fresh air intake pipe (HVAC type, must meet ULC S110 or UL 181 class 0 or class 1) **(B)**, sold separately. Refer to air intake kit installation instructions for more details.

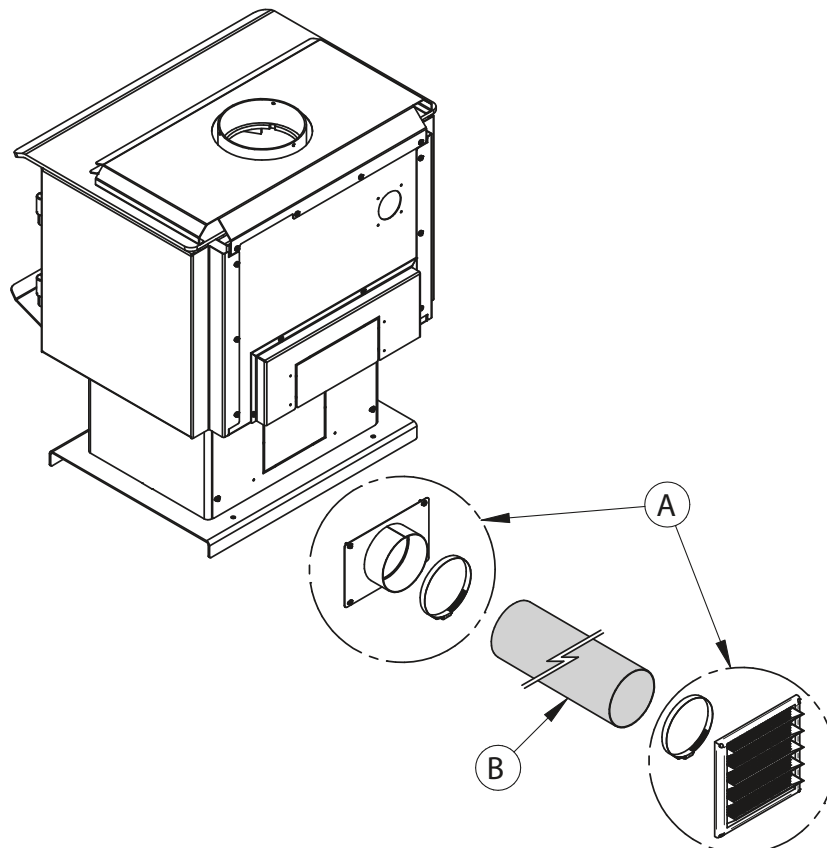

APPENDIX 2: OPTIONAL FIRE SCREEN INSTALLATION

1. Open the door.

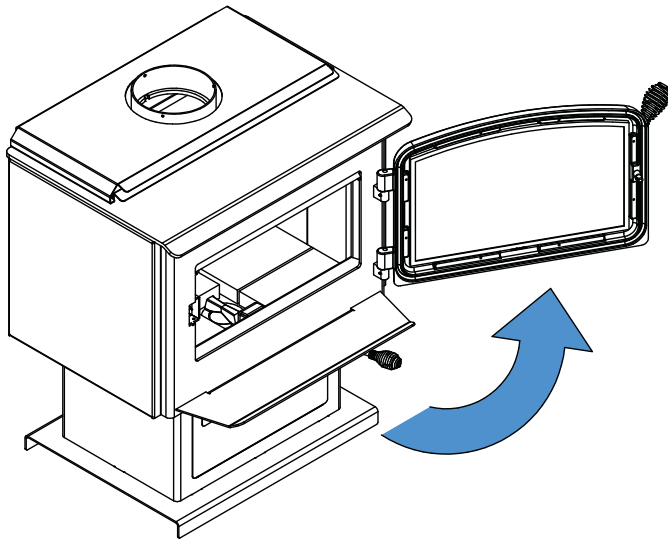

2. Hold the fire screen by the two handles and bring it close to the door opening.

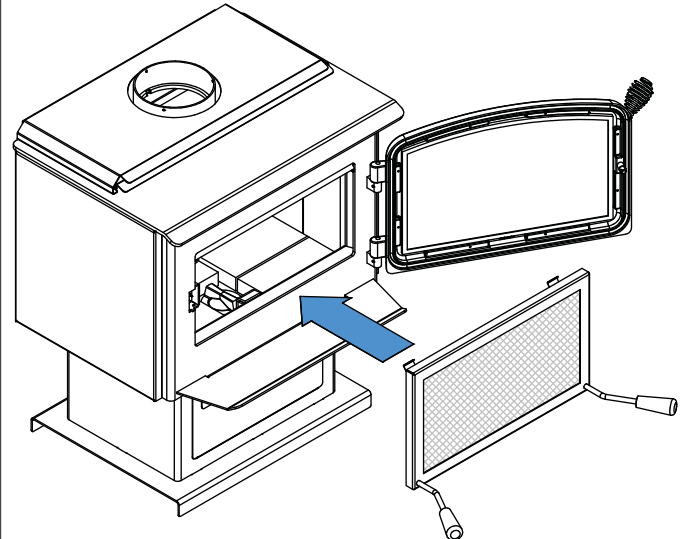

3. Lean the upper part of the fire screen against the top door opening making sure to stow the top fire screen brackets behind the primary air deflector.
4. Lift the fire screen upwards and push the bottom part towards the stove then let the fire screen rest on the bottom of the door opening.

Warning: Never leave the stove unattended while in use with the fire screen.

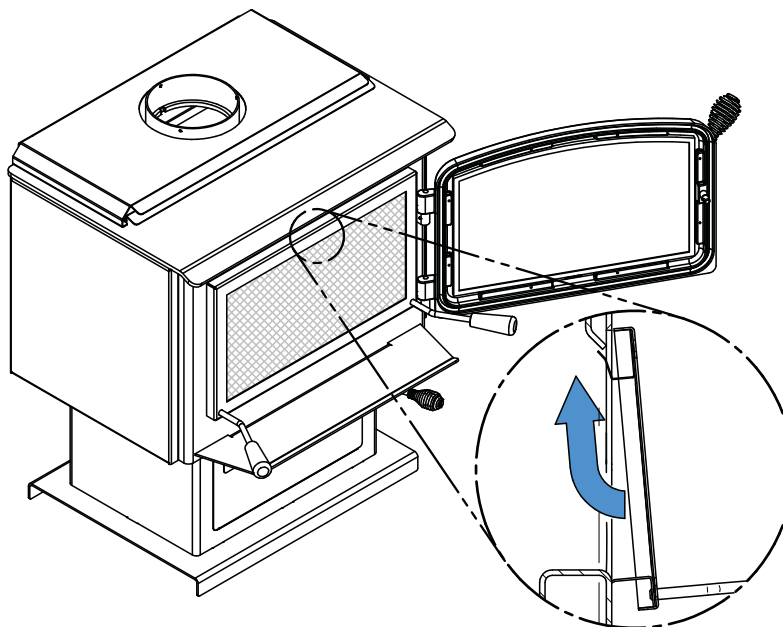

APPENDIX 3: OPTIONAL BLOWER INSTALLATION

A blower, sold separately, can be installed on the stove.

1. Remove the backplate by cutting the knockouts with pliers.

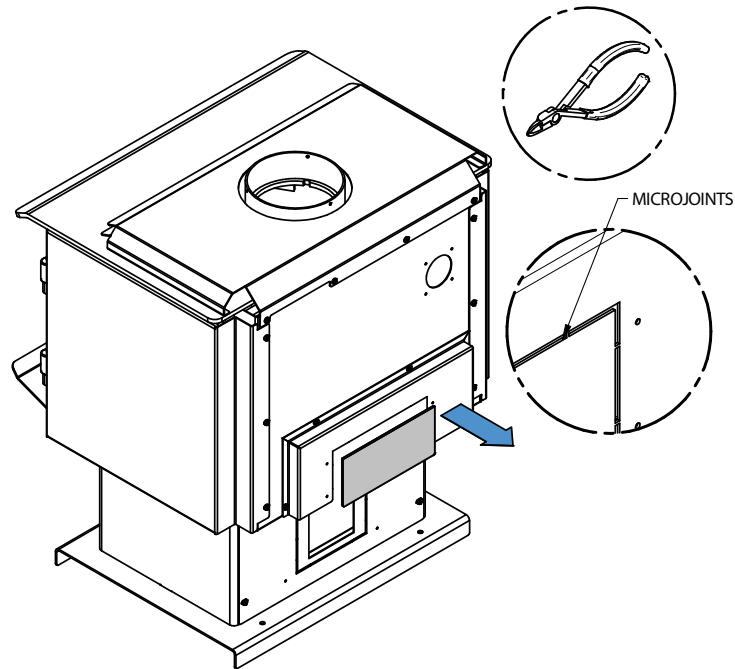

2. Screw the blower **(A)** in place using the screws **(B)** included in the installation manual.

Ensure that the blower's power cord is not in contact with any surface of the stove to prevent electrical shock or fire damage. Do not run the power cord beneath the stove.

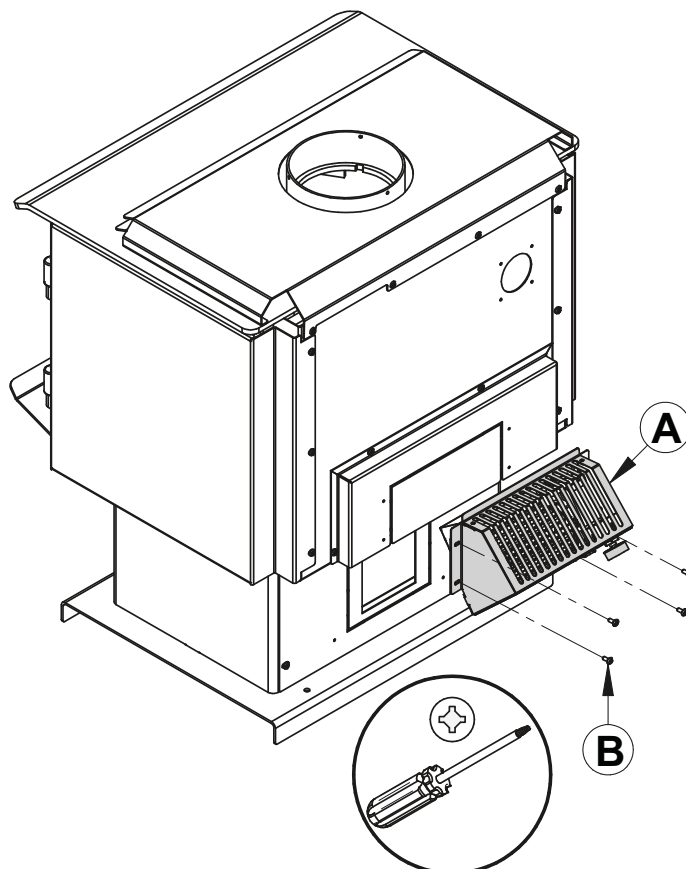

APPENDIX 4: OPTIONAL THERMODISC INSTALLATION

A thermodisc, sold separately, can be installed with the blower. It allows the fan to operate only when the stove is hot enough. See the instructions provided with the thermodisc for more details.

Screw the thermodisc **(C)** with the screws **(D)** provided on the back of the stove.

The electrical cord of the thermodisc should not touch any surface of the stove to avoid electric shock or fire. Do not run the power cord under the stove.

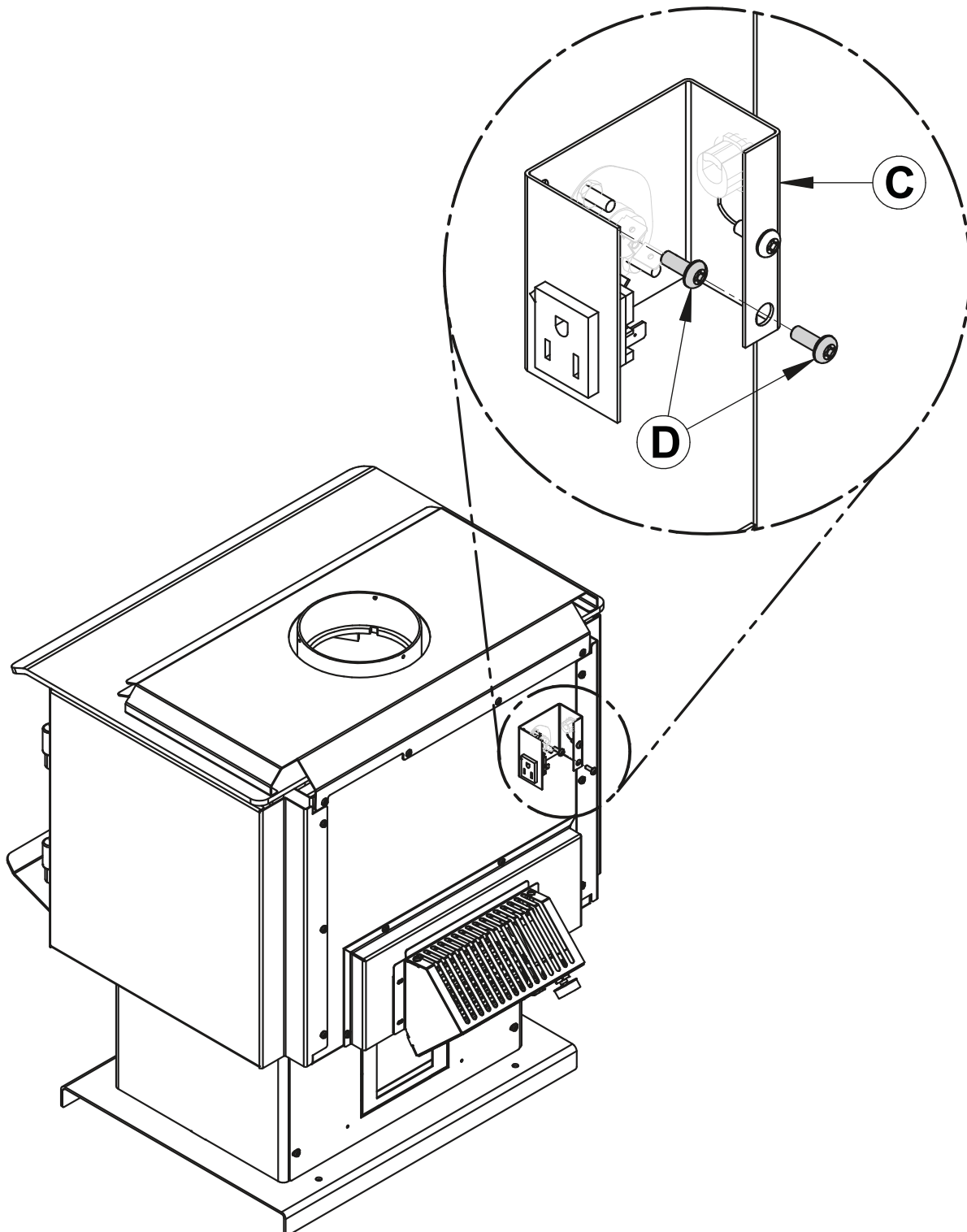

APPENDIX 5: REMOVING THE DECORATIVE PANELS

To remove the decorative panels **(A)**, remove the screws **(B)** and push forward on the panel to unhook it from the support **(C)**.

ENGLISH

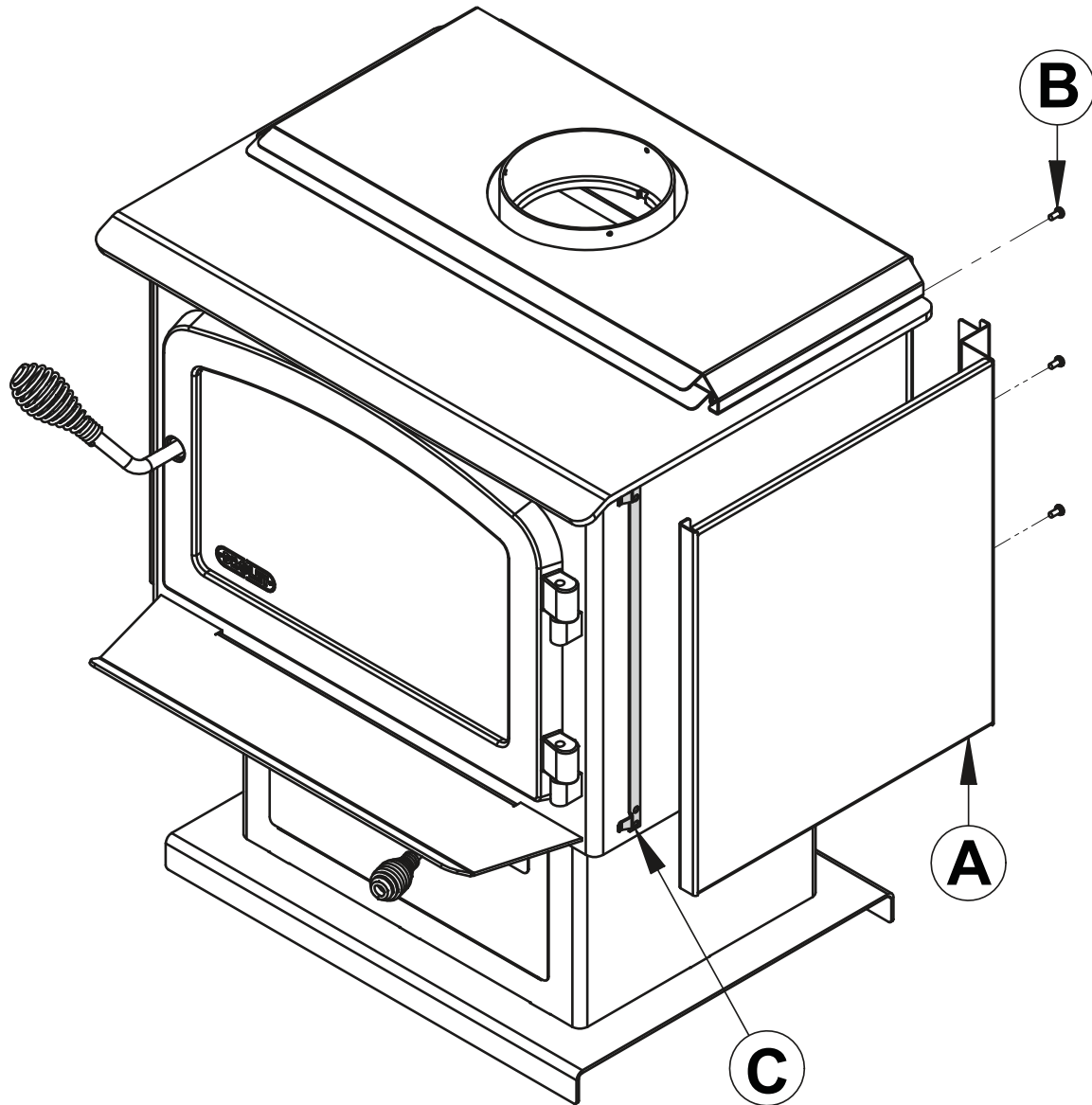

APPENDIX 6: AIR TUBES AND BAFFLE INSTALLATION

1. Starting with the rear tube, lean and insert the right end of the secondary air tube into the rear right channel hole. Then lift and insert the left end of the tube into the rear left channel.

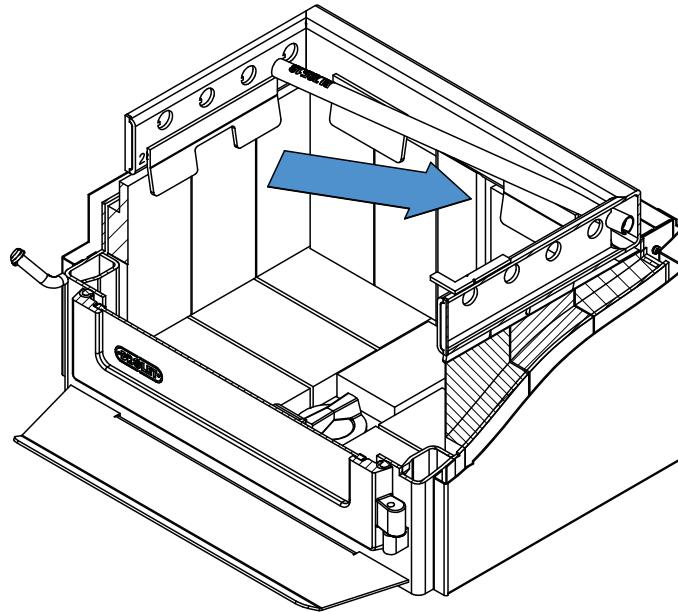

2. Align the notch in the left end of the tube with the key of the left air channel hole. Using a « Wise grip » hold the tube and lock it in place by turning the tube as shown. Make sure the notch reaches the end of the key way.
3. Put the baffle in place.
4. Repeat steps 1 and 2 for the three other tubes.
5. To remove the tubes use the above steps in reverse order.

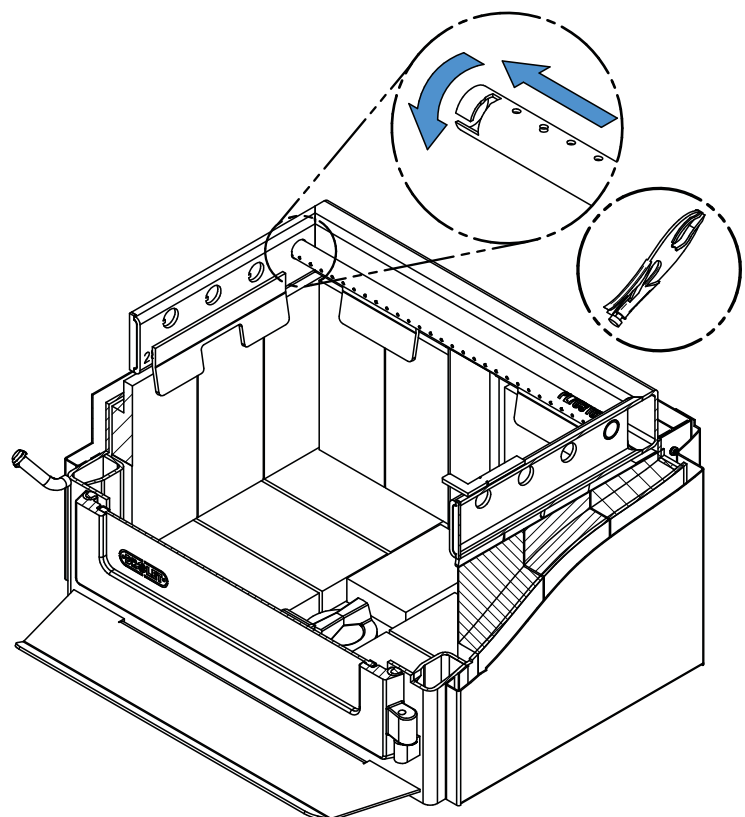

Note that secondary air tubes (B) can be replaced without removing the baffle board (A) and that all tubes are identical.

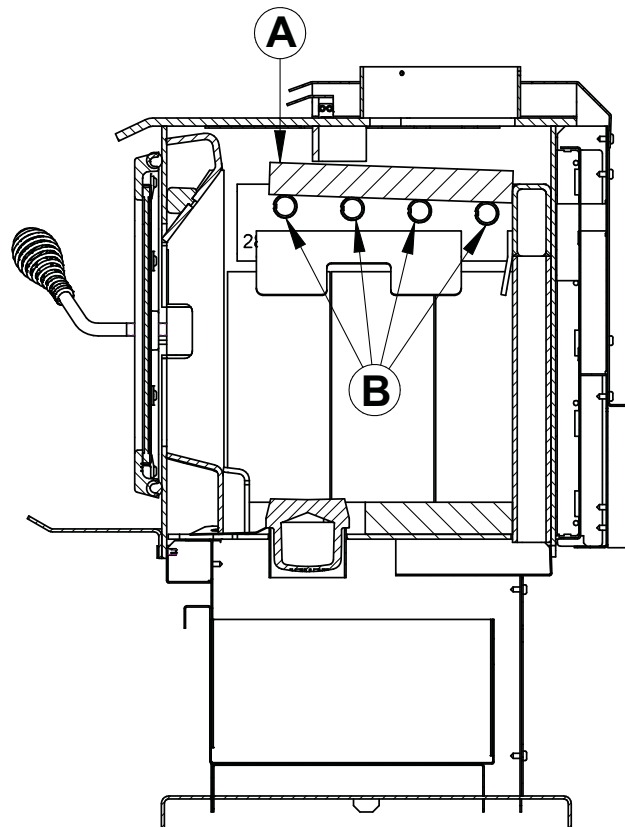
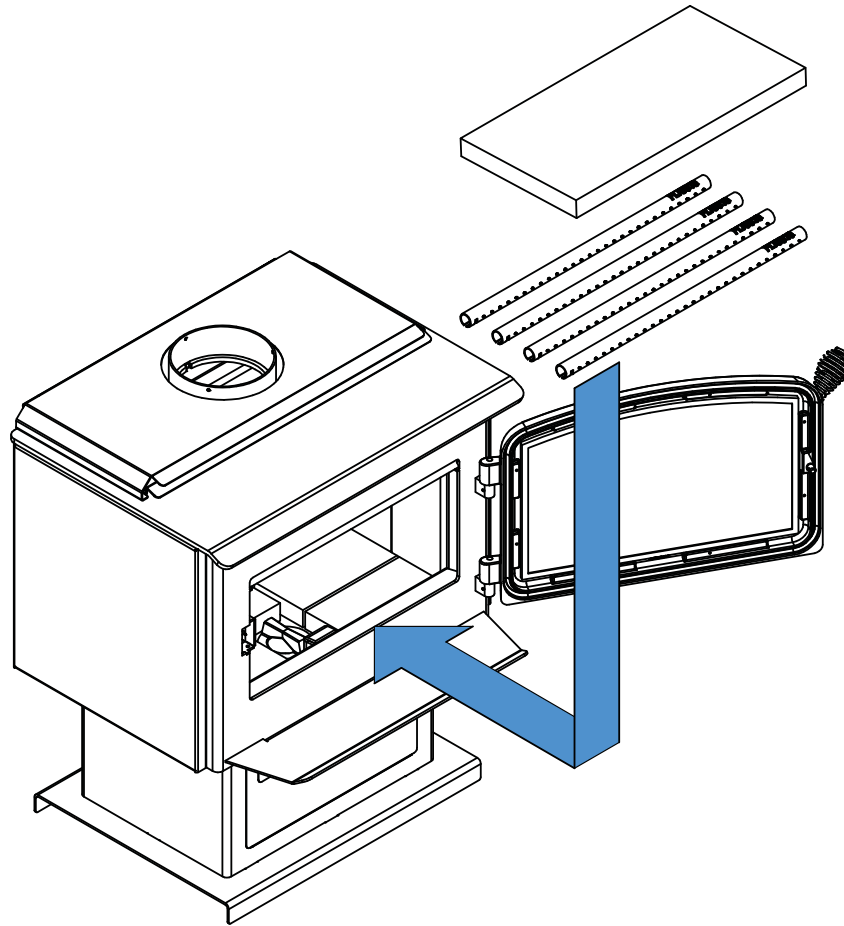

APPENDIX 7: MOBILE HOME INSTALLATION

For a stove on a pedestal, remove the plugs **(A)** and screw the base on the floor with the proper hardware **(B)**.

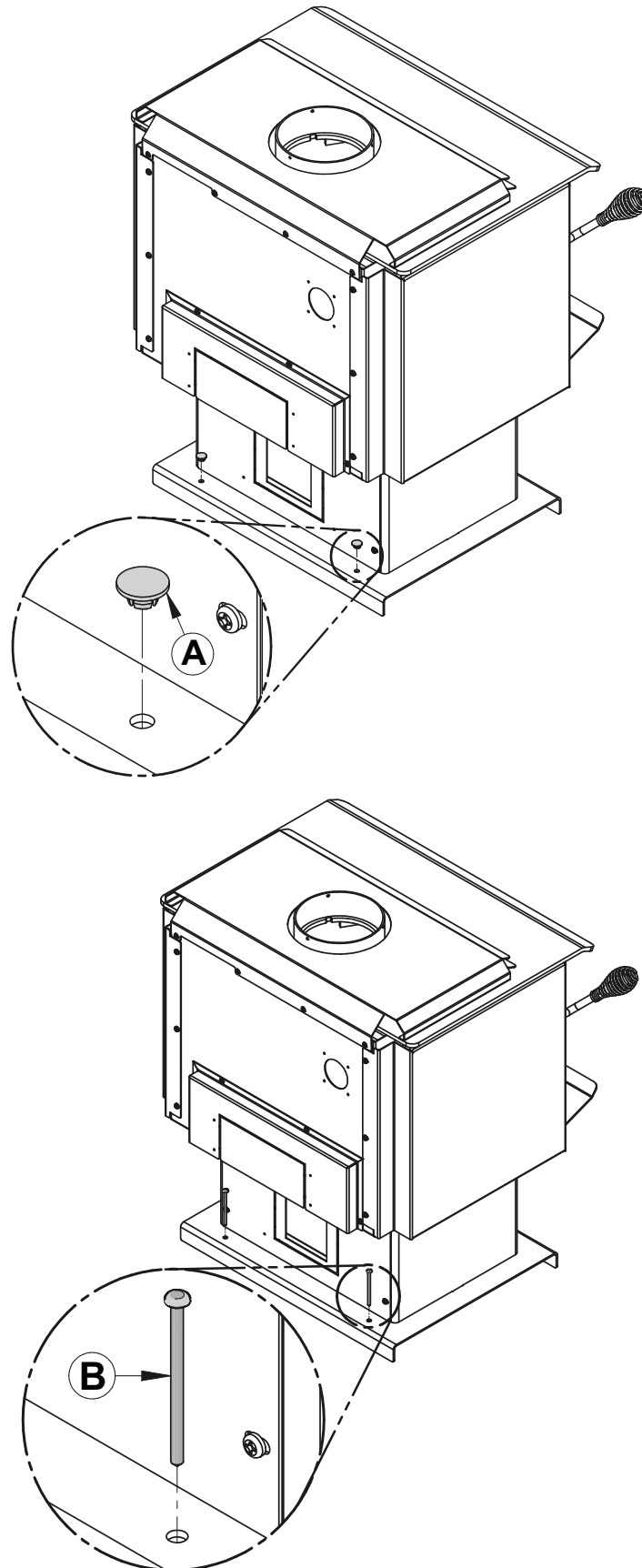

APPENDIX 8: EXPLODED DIAGRAM AND PARTS LIST

ENGLISH

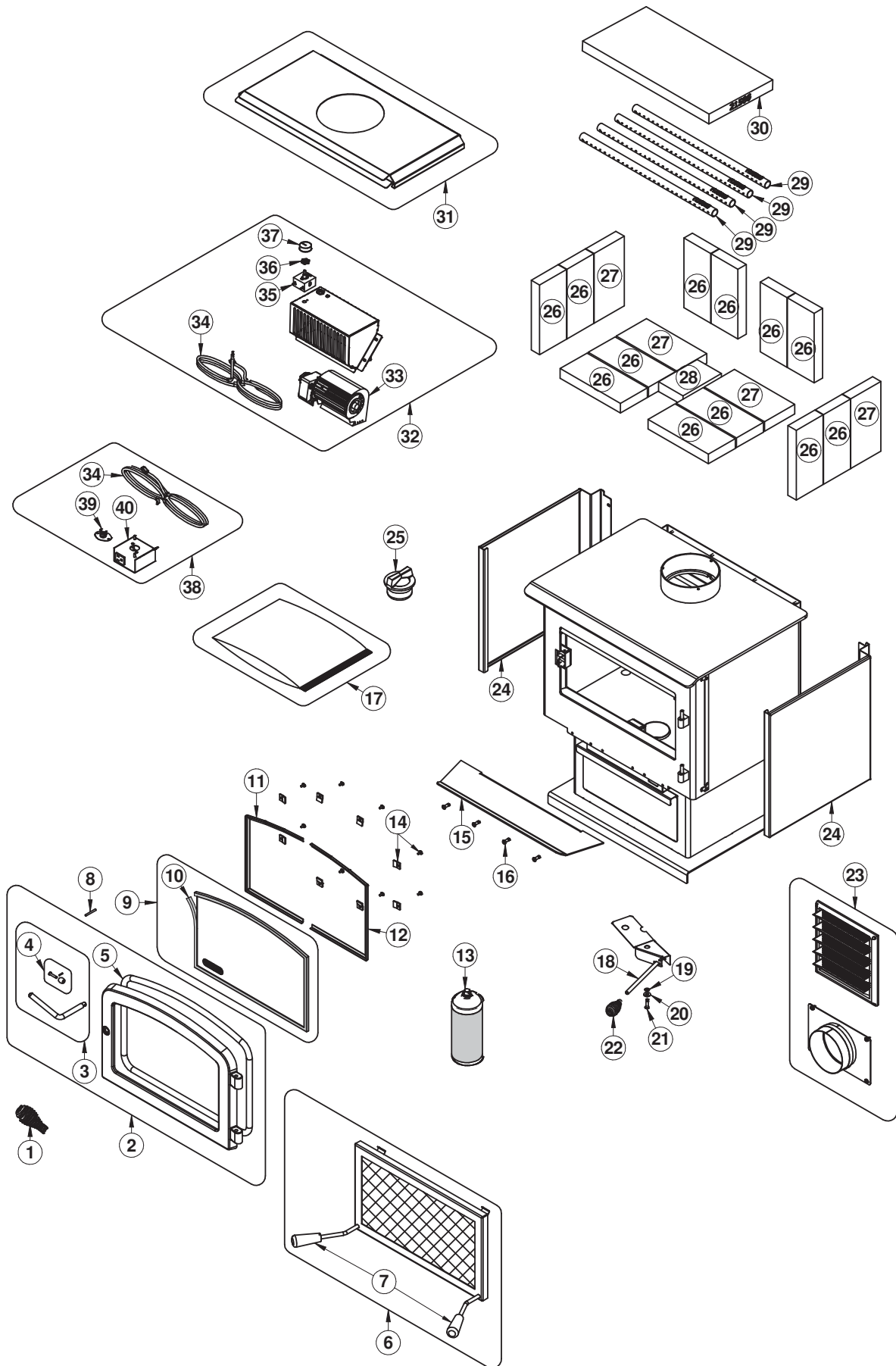

IMPORTANT: THIS IS DATED INFORMATION. When requesting service or replacement parts for your unit, please provide the model number and the serial number. We reserve the right to change parts due to technology upgrades or availability. Contact an authorized dealer to obtain any of these parts. Never use substitute materials. Use of non-approved parts can result in poor performance and safety hazards.

#	Item	Description	Qty
1	AC07867	1/2" CHROME PLATED COIL HANDLE	1
2	SE24300	CAST IRON DOOR WITH HANDLE AND GASKET	1
3	SE70697	REPLACEMENT HANDLE WITH LATCH KIT	1
4	AC09185	DOOR LATCH KIT	1
5	AC06500	SILICONE AND 5/8" X 8' BLACK DOOR GASKET KIT	1
6	AC01299	FIRE SCREEN	1
7	30569	ROUND WOODEN HANDLE BLACK	2
8	30101	SPRING TENSION PIN 5/32"Ø X 1 1/2"L	1
9	SE70700	REPLACEMENT GLASS WITH GASKET ESCAPE 1500	1
10	AC06400	3/4" (FLAT) X 6' BLACK SELF-ADHESIVE GLASS GASKET	1
11	PL70676	LEFT GLASS FRAME	1
12	PL70675	RIGHT GLASS FRAME	1
13	AC05959	METALLIC BLACK STOVE PAINT - 342 g (12oz) AEROSOL	1
14	SE53585	GLASS RETAINER KIT WITH SCREWS (12 PER KIT)	1
15	PL70621	ASH SHELF	1
16	30507	BLACK TORX SCREW WITH FLAT HEAD TYPE F 1/4-20 X 3/4"	4
17	SE45996	ESCAPE 1500 INSTRUCTIONS MANUAL KIT	1
18	SE70618	AIR CONTROL DAMPER ASSEMBLY	1
19	30187	STAINLESS WASHER ID 17/64" X OD 1/2"	1
20	30206	ZINC WASHER 5/16"ID X 3/4"OD	1
21	30506	SCREW PAN TORX TYPE F 1/4-20 X 1" BLACK	1
22	30429	3/8" NICKEL COIL HANDLE	1
23	AC01336	5"Ø FRESH AIR INTAKE KIT FOR WOOD STOVE ON PEDESTAL	1
24	PL70625	DECORATIVE PANEL	2
25	24096	ROUND CAST IRON ASH PLUG	1
26	29015	4" X 9" X 1 1/4" REFRACTORY BRICK	12
27	29010	4 1/2" X 9" X 1 1/4" REFRACTORY BRICK	4
28	PL36270	4" X 8" X 1/2" X 1 1/4" REFRACTORY BRICK	1
29	PL70516	SECONDARY AIR TUBE	4
30	21586	VERMICULITE BAFFLE	1
31	SE70626	AIRMATE	1
32	AC02050	BLOWER ASSEMBLY WITH VARIABLE SPEED CONTROL (UP TO 100 CFM)	1
33	44073	CROSSFLOW BLOWER 115V-60Hz-39W 100 CFM	1
34	60013	POWER CORD 96" X 18-3 type SJT (50 pcs per carton)	1
35	44080	RHEOSTAT WITHOUT NUT (MODEL KBMS-13BV)	1

#	Item	Description	Qty
36	44087	RHEOSTAT NUT	1
37	44085	RHEOSTAT KNOB	1
38	AC02055	QUICK CONNECT THERMODISC KIT	1
39	44028	CERAMIC THERMODISC F110-20F	1
40	PL05530-02	THERMODISC BOX (COVER)	1

DROLET LIMITED LIFETIME WARRANTY

The warranty of the manufacturer extends only to the original retail purchaser and is not transferable. This warranty covers brand new products only, which have not been altered, modified nor repaired since shipment from the factory. Proof of purchase (dated bill of sale), model name and serial number must be supplied when making any warranty claim to the DROLET dealer.

This warranty applies to normal residential use only. This warranty is void if the unit is used to burn material other than cordwood (for which the unit is not certified by EPA) and void if not operated according to the owner's manual. Damages caused by misuse, abuse, improper installation, lack of maintenance, over firing, negligence or accident during transportation, power failures, downdrafts, venting problems or underestimated heating area are not covered by this warranty. The recommended heated area for a given appliance is defined by the manufacturer as its capacity to maintain a minimum acceptable temperature in the designated area in case of a power failure.

This warranty does not cover any scratch, corrosion, distortion, or discoloration. Any defect or damage caused by the use of unauthorized or other than the original parts voids this warranty. An authorized qualified technician must perform the installation in accordance with the instructions supplied with this product and all local and national building codes. Any service call related to an improper installation is not covered by this warranty.

The manufacturer may require that defective products be returned or that digital pictures be provided to support the claim. Returned products are to be shipped prepaid to the manufacturer for investigation. Transportation fees to ship the product back to the purchaser will be paid by the manufacturer. Repair work covered by the warranty, executed at the purchaser's domicile by an authorized qualified technician requires the prior approval of the manufacturer. All parts and labour costs covered by this warranty are limited according to the table below.

The manufacturer, at its discretion, may decide to repair or replace any part or unit after inspection and investigation of the defect. The manufacturer may, at its discretion, fully discharge all obligations with respect to this warranty by refunding the wholesale price of any warranted but defective parts. The manufacturer shall, in no event, be responsible for any uncommon, indirect, consequential damages of any nature, which are in excess of the original purchase price of the product. A one-time replacement limit applies to all parts benefiting from lifetime coverage. This warranty applies to products purchased after March 1st 2019.

DESCRIPTION	WARRANTY APPLICATION*	
	PARTS	LABOUR
Combustion chamber (welds only) and cast iron door frame.	Lifetime	3 years
Surrounds, heat shields, ash drawer, steel legs, pedestal, trims (aluminum extrusions), plating (defective manufacture**), and convector air-mate.	5 years	3 years
Removable stainless steel combustion chamber components, secondary air tubes**, deflectors, and supports.	5 years	N/A
Glass retainers, handle assembly, and air control mechanism.	3 years	1 year
Carbon steel combustion chamber components, vermiculite baffle**, and C-Cast baffle**.	2 years	N/A
Standard blower, heat sensors, switches, rheostat, wiring, and other controls.	1 year	1 year
Optional blower, paint (peeling**), ceramic glass (thermal breakage only**), ceramic fibre blankets, gaskets, insulation, and other options.	1 year	N/A
Firebricks.	N/A	N/A
All parts replaced under the warranty.	90 days	N/A

*Subject to limitations above. **Picture required.

Labour cost and repair work to the account of the manufacturer are based on a predetermined rate schedule and must not exceed the wholesale price of the replacement parts. Shall your unit or a component be defective, contact immediately your DROLET dealer. To accelerate processing of your warranty claim, make sure to have on hand the following information when calling:

- Your name, address and telephone number;
- Bill of sale and dealer's name;
- Installation configuration;
- Serial number and model name as indicated on the nameplate fixed to the back of your unit;
- Nature of the defect and any relevant information.

Before shipping your unit or defective component to our plant, you must obtain an Authorization Number from your DROLET dealer. Any merchandise shipped to our plant without authorization will be refused automatically and returned to the sender.

This document is available for free download on the manufacturer's website. It is a copyrighted document. Resale is strictly prohibited. The manufacturer may update this document from time to time and cannot be responsible for problems, injuries, or damages arising out of the use of information contained in any document obtained from unauthorized sources.



Stove Builder International inc.
250, rue de Copenhague,
St-Augustin-de-Desmaures (Québec) Canada
G3A 2H3
418-908-8002
<https://www.drolet.ca/en/>
tech@sbi-international.com