



# Installation and Operation Manual

## ATLAS WOOD BURNING COOKSTOVE

(DB04810 model)

ENGLISH

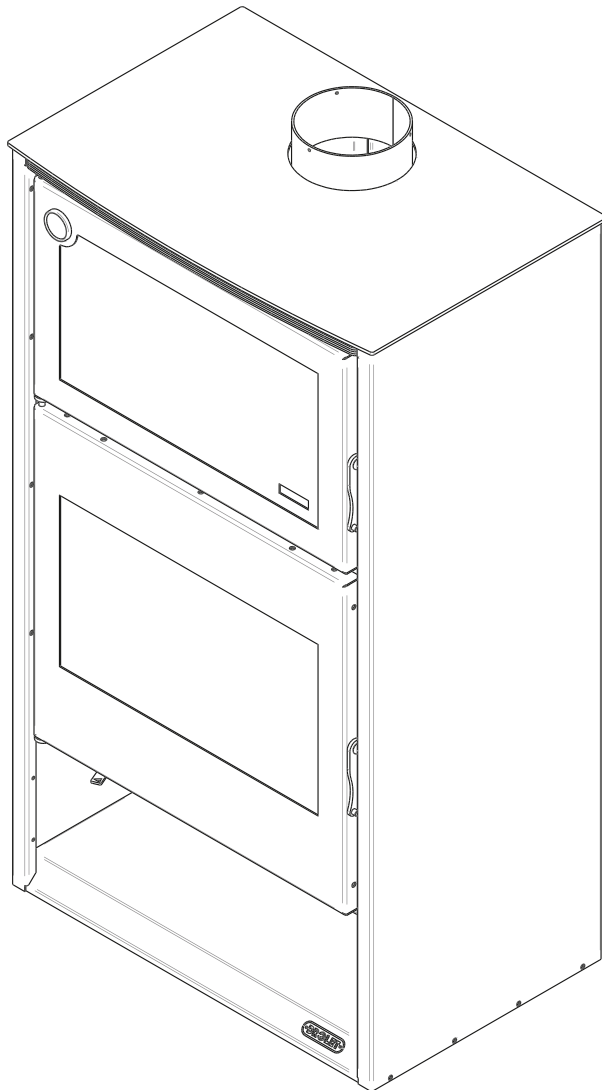

Security test made according to regulations ULC S627 and UL 1482 by an accredited laboratory.

**READ AND KEEP THIS MANUAL FOR REFERENCE**



# THANK YOU FOR CHOOSING THIS WOOD BURNING COOKSTOVE.

**If this cookstove is not installed properly, combustible materials near it may overheat and catch fire.**

**To reduce the risk of fire, follow the installation instructions in this manual.**

As one of North America's largest and most respected wood stove and fireplace manufacturers, Stove Builder International takes pride in the quality and performance of all its products.

The following pages provide general advice on wood heating, detailed instructions for safe and effective installation, and guidance on how to get the best performance from this cookstove.

It is highly recommended that this cookstove be installed and serviced by professionals who are certified in the United States by NFI (National Fireplace Institute®) or in Canada by WETT (Wood Energy Technology Transfer) or in Quebec by APC (Association des Professionnels du Chauffage).

Contact local building or fire officials about restrictions and installation inspection requirements in your local area.

A building permit might be required for the installation of this cookstove and the chimney that it is connected to. It is also highly recommended to inform your home insurance company.

Please read this entire manual before installing and using this cookstove.

## ONLINE WARRANTY REGISTRATION

If the unit requires repairs during the warranty period, proof of purchase must be provided. The purchase invoice must be kept. The date indicated on it establishes the warranty period. If it can not be provided, the warranty period will be determined by the date of manufacture of the product.

It is also highly recommended to register the warranty online at

<https://www.drolet.ca/en/warranty/warranty-registration/>

Registering the warranty will help to quickly find the information needed on the unit.

# TABLE OF CONTENTS

<b>PART A - OPERATION AND MAINTENANCE .....</b>	<b>7</b>
<b>1. Safety Information.....</b>	<b>7</b>
<b>2. General information .....</b>	<b>8</b>
2.1 Specifications .....	8
2.2 Cookstove Dimensions .....	9
<b>3. Fuel.....</b>	<b>10</b>
3.1 Recommended Fuel.....	10
<b>4. Stove Operation .....</b>	<b>10</b>
4.1 Components Location .....	10
4.2 Cooking.....	11
4.3 First Fires.....	11
4.4 Lighting a Fire .....	11
4.5 Maintaining Wood Fires.....	12
4.6 Adjusting Primary and Secondary Air Inlet .....	13
<b>5. Cookstove Maintenance.....</b>	<b>15</b>
5.1 Cleaning and Painting the Cookstove.....	15
5.2 Vermiculite Slabs and Baffle .....	15
5.3 Combustion Chamber .....	15
5.4 Grills and Trays .....	15
5.5 Glass Maintenance .....	15
<b>6. Chimney Maintenance .....</b>	<b>17</b>
6.1 Why Sweep the Chimney? .....	17
6.2 Cleaning Frequency.....	17
6.3 Chimney Sweeping.....	17
<b>PART B - INSTALLATION.....</b>	<b>18</b>
<b>7. Safety Information.....</b>	<b>18</b>
7.1 Regulations Governing the Installation of the Cookstove .....	18
<b>8. Clearances to Combustible Materials.....</b>	<b>18</b>
8.1 Cookstove Positioning .....	19
8.2 Location of the Certification Label .....	19
8.3 Cookstove Clearances to Combustible Materials .....	19
8.4 Clearances Reduction to the Walls and the Ceiling .....	22
8.5 Clearances for Shield Installation .....	24
<b>9. The Exhaust System .....</b>	<b>25</b>
9.1 General Information .....	25
9.2 Suitable Chimneys.....	25
9.3 Chimney Height.....	26

10. Combustion Air Supply ..... 27

11. Chimney Connector Installation ..... 27

    11.1 Single Wall Chimney Connector Installation .....27

12. Troubleshooting ..... 30

13. Exploded View and Parts List ..... 31

Atlas Cooking Stove Limited Lifetime Warranty .....34

Dealer:	_____
Installer:	_____
Phone Number:	_____
<b>Serial Number:</b>	_____

# CERTIFICATION PLATE



REFER TO INTERTEK'S DIRECTORY OF BUILDING PRODUCTS FOR  
 DETAILED INFORMATION  
 SE RÉFÉRER AU RÉPERTOIRE DES PRODUITS HOMOLOGUÉS  
 D'INTERTEK POUR PLUS D'INFORMATION

Control number: 4002461  
 STANDARDS / NORMES D'ESSAI:  
 Certified to / Certifié selon ULC S627  
 Certified to / Certifié selon UL 1482  
 (Mai / May 2018)

**LISTED SOLID FUEL BURNING APPLIANCE**  
**POÊLE À COMBUSTIBLE SOLIDE HOMOLOGUÉ**  
**MODEL / MODÈLE : ATLAS**

Serial Number / No. de Série: **1**

## Clearances to combustibles / Dégage­ments aux combustibles

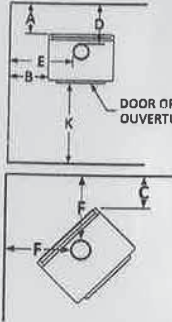

CANADA / U.S.A.  
 Single or Double wall connector  
 Tuyau à paroi simple ou double

A:	15.5 in./po. (394mm)
B:	13 in./po. (330 mm)
C:	12 in./po. (305 mm)
D:	18 in./po. (457 mm)
E:	23.5 in./po. (597 mm)
F:	21.5 in./po. (546 mm)

With Heat Shield AC02710  
 Avec écran mural AC02710

CANADA / U.S.A.  
 Double wall connector  
 Tuyau à paroi double

A:	2.5 in./po. (64 mm)
B:	2.5 in./po. (64 mm)
C:	2.5 in./po. (64 mm)
D:	5 in./po. (127 mm)
E:	12.5 in./po. (318 mm)
F:	12.5 in./po. (318 mm)

With Heat Shield AC02784  
 Avec écran pare-cha­leur AC02784

CANADA / U.S.A.  
 Double wall connector  
 Tuyau à paroi double

A:	6 in./po. (152 mm)
B:	13 in./po. (330 mm)
C:	12 in./po. (305 mm)
D:	8.5 in./po. (216 mm)
E:	23.5 in./po. (597 mm)
F:	21.5 in./po. (546 mm)

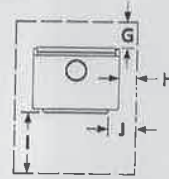

Dégagement devant la cuisinière: CAN: K: 48 in./po. (1219 mm)  
 Clearance in front of the cook stove: USA: K: 36 in./po./K: 914 mm

Minimum floor to ceiling distance / Distance minimale plafond-plancher: 84 in./po. (213cm)

Floor protection  
 Protection de plancher

G:	8 in./po. (203 mm) CANADA
H:	8 in./po. (203 mm) CANADA
I:	18 in./po. (457 mm) CANADA
	16 in./po. (406 mm) USA
J:	8 in./po. (203 mm) USA

### PREVENT HOUSE FIRES

- Install and use only in accordance with the manufacturer's installation and operating instructions.
- Contact local building or fire officials about restrictions and installation inspection in your area.
- Use listed 152 mm / 6 in. diameter single or double wall connectors with prefabricated chimneys suitable for solid fuels or lined masonry chimneys.
- See local building code and manufacturer's instructions for precautions required for passing a chimney through a combustible wall or ceiling.
- Do not pass connector through combustible wall or ceiling.
- Do not connect this unit to a chimney serving another appliance.
- Use with wood only. Do not use other fuels.
- Operate only with door closed. Open door to feed fire only.
- Do not obstruct the space underneath the stove.
- Do not use grate or elevate fire. Build fire directly on hearth.
- Do not overfire. If heater or chimney connector glows, you are overfiring.
- Inspect and clean chimney frequently. Under certain condition of use, creosote buildup may occur rapidly.
- Replace glass with ceramic type only.
- Install unit on a non-combustible material extending as shown above on this label.
- This wood heater needs periodic inspection and repair for proper operation. Consult the owner's manual for further information. It is against US federal regulations to operate this wood heater in a manner inconsistent with the operating instructions in the owner's manual.

### PRÉVENEZ LES INCENDIES

- Installer et utiliser conformément au manuel d'utilisation du fabricant.
- Contacter les autorités de votre localité ayant juridiction concernant les restrictions et inspections d'installation.
- Utiliser des tuyaux d'évacuation à parois simple ou double homologués d'un diamètre de 6 po. (152 mm) avec une cheminée préfabriquée approuvée pour utilisation au bois ou une cheminée de maçonnerie gainée.
- Voir les codes locaux et le manuel d'installation du fabricant pour le passage de la cheminée à travers un mur ou un plafond combustible.
- Ne pas traverser un plafond ou un mur combustible avec un tuyau d'évacuation.
- Ne pas raccorder cet appareil à une cheminée desservant un autre appareil.
- Brûler du bois seulement. Ne pas utiliser d'autres combustibles.
- N'ouvrir la porte que lors du chargement.
- Ne rien entreposer sous l'appareil.
- Ne pas utiliser de grilles ou de chenets pour surélever le feu. Préparer le feu directement sur l'âtre.
- Ne pas surchauffer. Si l'appareil ou le tuyau rougit, il y a surchauffe.
- Inspecter et nettoyer la cheminée fréquemment. Dans certaines conditions, l'accumulation de crésote peut être rapide.
- Remplacer la vitre seulement avec un verre de céramique.
- Installer l'appareil sur une plaque non combustible tel qu'indiqué sur l'étiquette.
- Cet appareil de chauffage requiert des inspections et réparations périodiques. Consulter le manuel de l'utilisateur pour plus d'information. Opérer cet appareil de chauffage de façon inconsistante par rapport au manuel de l'utilisateur consiste une violation de la loi fédérale (USA).

"U.S. ENVIRONMENTAL PROTECTION AGENCY This unit is not a certified residential wood heater. The primary use for this unit is for cooking or baking".  
 "AGENCE DE PROTECTION DE L'ENVIRONNEMENT DES É.U. (EPA) Cette unité n'est pas un appareil de chauffage au bois résidentiel certifié. L'utilisation principale de cette unité concerne la cuisson."

**WARNING:** This product can expose you to carbon monoxide, which is known to the State of California to cause cancer, birth defects or other reproductive harm. (For more information go to [www.p65warnings.ca.gov](http://www.p65warnings.ca.gov))



## CAUTION

- HOT WHILE IN OPERATION.
- DO NOT TOUCH. KEEP CHILDREN, CLOTHING AND FURNITURE AWAY.
- CONTACT MAY CAUSE SKIN BURNS. SEE NAME-PLATE AND INSTRUCTIONS.

Distributed by /  
 Distribué par:



Made in Spain

## ATTENTION

- CHAUD EN FONCTIONNEMENT.
- NE PAS TOUCHER. GARDER LES ENFANTS, LES VÊTEMENTS ET LES MEUBLES ÉLOIGNÉS.
- UN CONTACT AVEC LA PEAU PEUT OCCASIONNER DES BRÛLURES. VOIR LES INSTRUCTIONS.

Fabriqué en Espagne

27738

ENGLISH

# PART A - OPERATION AND MAINTENANCE

## 1. Safety Information

- Operate only with doors fully closed. If door is left partly open, gas and flame may be drawn out of the opening, creating risks from both fire and smoke.
- The cookstove is not designed to be used when the door is open. Open the door only to startup or to reload the stove.
- Don't leave unattended when the door is slightly open for startups. Always close the door after ignition.
- **HOT WHILE IN OPERATION, KEEP CHILDREN, CLOTHING AND FURNITURE AWAY. CONTACT MAY CAUSE SKIN BURNS. GLOVES MAY BE NEEDED FOR COOKSTOVE OPERATION.**
- Using the cookstove with cracked or broken components, such as glass, firebricks or baffle may produce an unsafe condition and may damage the cookstove.
- Open the air control fully before opening the combustion chamber door.
- Do not store fuel within cookstove minimum installation clearances.
- Do not wood in the accessory compartment, underneath the combustion chamber. .
- Burn only seasoned natural firewood.
- Do not elevate the fire by using a grate.
- A smoke detector, a carbon monoxide detector and a fire extinguisher should be installed in the house. The location of the fire extinguisher should be known by all family members.
- **DO NOT USE CHEMICALS OR FLUIDS TO START THE FIRE.**
- **DO NOT BURN GARBAGE OR FLAMMABLE LIQUIDS SUCH AS GASOLINE, NAPHTHA, FUEL OIL, ENGINE OIL, KEROSENE, CHARCOAL LIGHTER FUEL, SIMILAR LIQUIDS, OR AEROSOLS TO START, REVIVE OR NEAR THE FIRE. KEEP ALL SUCH LIQUIDS WELL AWAY FROM THE HEATER WHILE IT IS IN USE.**
- This appliance should always be maintained and operated in accordance with these instructions.



**WARNING:** This product can expose you to chemicals including carbon monoxide, which is known to the State of California to cause cancer, birth defects or other reproductive harm. For more information go to [www.P65warnings.ca.gov](http://www.P65warnings.ca.gov)

## 2. General information

### 2.1 Specifications

Model	Atlas woodburning cookstove (DB04810)
Fuel Type	Dry Cordwood
Recommended log length	15 - 18 in (400 - 500 mm)
Flue outlet diameter	6 in (150 mm)
Chimney diameter	6 in (150 mm)
Type of chimney	UL 103 HT, ULC S629
Necessary flue draft	0,05" H <sub>2</sub> O (12 Pa)
Alcove installation	Not approved
Mobile home installation <sup>‡</sup>	Not approved
Shipping weight	330 lb (150 kg)
American standards (security)	UL 1482
Canadian standards (security)	ULC S627
Oven dimensions (WxDxH)	21 ½" x 13" x 8 ¾" (546 mm x 330 mm x 222 mm)

ENGLISH

‡Mobile home (Canada) or prefabricated home (USA): The US department of Housing and urban development describes "prefabricated homes" better known as "mobile homes" as follows; constructed buildings on fixed wheels and those transported on temporary wheels/axles installed on a permanent foundation. In Canada, a mobile home is a dwelling which the assembly of each component is done or mostly done before moving it to a location where it will be placed on foundations and connected to service facilities that meet the standards CAN/CSA-Z240 MH.



## 2.2 Cookstove Dimensions

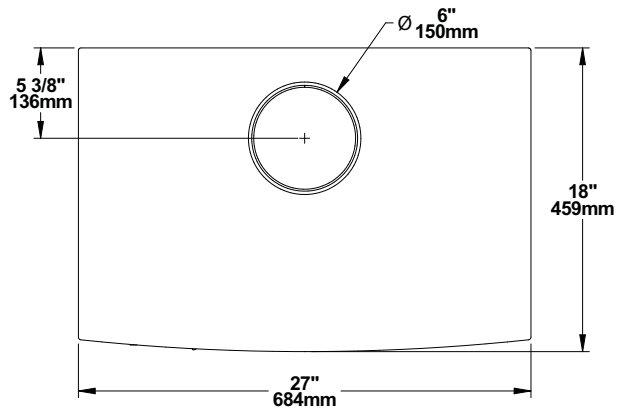

Figure 1: Top view

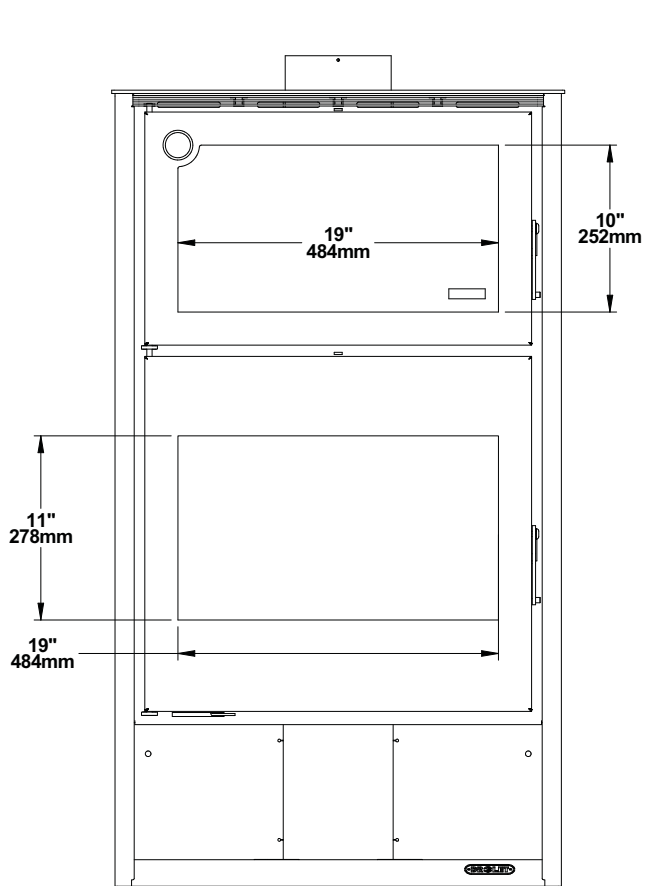

Figure 2: Front view

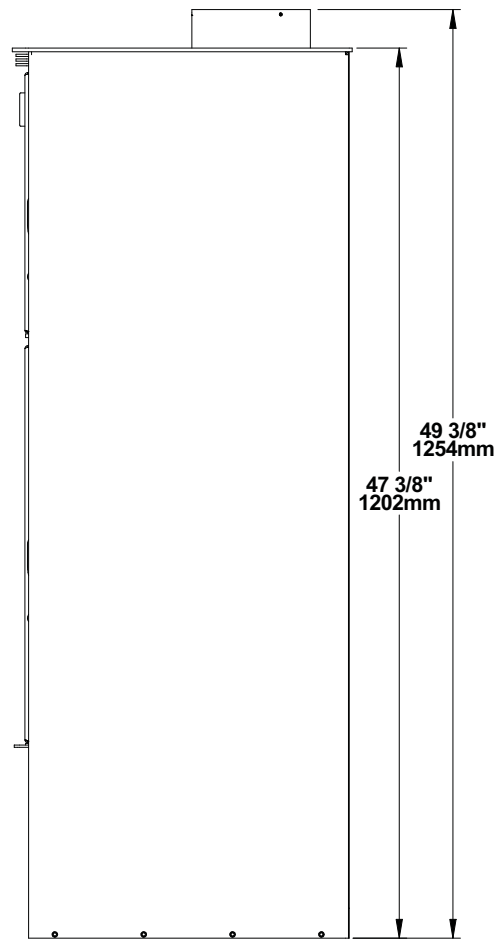

Figure 3: Side view

## 3. Fuel

### 3.1 Recommended Fuel

Wood burner performance depends greatly on the fuel used. Good firewood has been cut to the correct length for the appliance, split to a range of sizes and stacked in the open until its moisture content is down to 15% to 20%. Proper fuel makes it easier to regulate heat and keep the wood burner and flue in better condition.

Use split pieces of wood, they will burn better than logs. Make sure to have various size of wood. Thin firewood should be used to get higher thermal power, use it after lighting the fire for a faster response as more heat is needed. Use thick wood for a slower combustion when less heat is needed or for overnight fire. If necessary, when starting the fire, burn a combination of thin and thick firewood.

Store firewood in a dry, ventilated place protected from the rain for one to two years depending on the storage and weather conditions.

**DO NOT BURN GARBAGE OF ANY KIND, COAL OR CHARCOAL, TREATED, PAINTED OR COATED WOOD, PLYWOOD OR PARTICLE BOARD, FINE PAPER, COLORED PAPER OR CARDBOARD, SALT WATER DRIFTWOOD, MANUFACTURED LOGS CONTAINING WAX OR CHEMICAL ADDITIVES, RAILROAD TIES AND LIQUIDS SUCH AS KEROSENE OR DIESEL FUEL TO START A FIRE.**

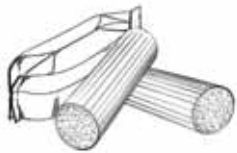

Do not burn manufactured logs made of wax impregnated sawdust or logs with any chemical additives. Manufactured logs made of 100% compressed sawdust can be burned with caution in the number of these logs burned at one time. Start with one manufactured log and see how the cookstove reacts. Never use more than two manufactured logs.

## 4. Stove Operation

### 4.1 Components Location

<b>A</b>	Oven thermometer
<b>B</b>	Combustion chamber
<b>C</b>	Air control
<b>D</b>	Accessory compartment
<b>E</b>	Cleaning access panel
<b>F</b>	Oven
<b>G</b>	Cooking grills
<b>H</b>	Ash pan

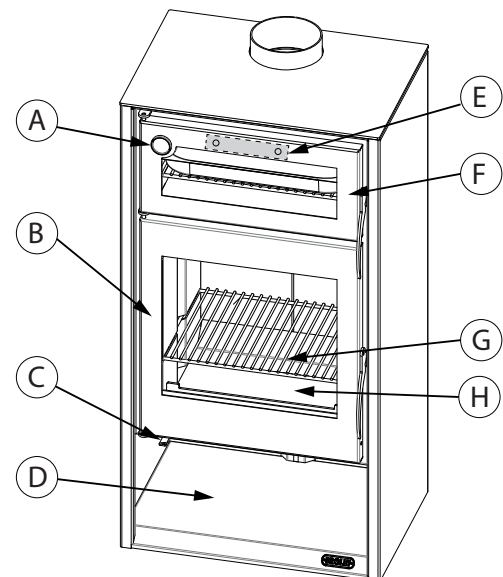

Figure 4: Component Location



*It is prohibited to put or store: alcohol, gasoline, liquid fuel, flammable materials, ashes, paper and wood in the accessory compartment.*

## 4.2 Cooking

Cooking can be done in the stainless steel oven, using the cooking grills and the trays provided with the cookstove. It can also be done in the combustion chamber, using the cooking grills only. *Do not use the trays in the combustion chamber.*

The panoramic windows allow you to see the cooking or baking without having to open the door. The door's integrated thermometer simplifies the reading of the oven temperature. The temperature indicated by the thermometer is only used as a reference. During cooking, keep the oven door closed to keep a constant temperature.

## 4.3 First Fires

Before ignition, make sure the chimney is clean and clear. The cookstove startup must be done only when all the installation steps for the cookstove and the chimney have been completed.

During the first fires, the cookstove will give off an unpleasant smell along with a light smoke. This has to do with the hardening of the paint process. The paint heats up, hardens, and adheres to metal. The smell and the smoke will disappear when the cookstove has been heated for several hours. Increase the fire intensity gradually. Open a window. **Even though the smoke and the smell are unpleasant, they are not toxic.**

## 4.4 Lighting a Fire

Load a generous amount of firewood, placing a layer of wood chips or thin firewood and another layer of thicker wood on top. You must leave the pieces crossed and with enough separation between them to allow proper air flow.

Light the first layer of wood chips or thin wood using fire-starters or special lighting products, if necessary.

Leave the door ajar, so that enough air can enter for the fire to light quickly.

Once the wood is well-lit, wait until the temperature is high before completely closing the door (10 to 45 minutes, depending on factors like wood, air circulation, etc.) and adjust the air inlet. If you find that the volume of flames decreases, or the fire tends to go out and the smoke inside the fireplace increases, open the air intake more or repeat the previous step.

When reloading, if there are not enough embers to light the new load of wood, open the door and the air inlet.

**DO NOT USE FLAMMABLE LIQUIDS SUCH AS GASOLINE, NAPHTHA, FUEL OIL, MOTOR OIL, OR AEROSOLS TO START OR REKINDLE THE FIRE.**

**DO NOT LEAVE THE COOKSTOVE UNATTENDED WHEN THE DOOR IS SLIGHTLY OPENED. ALWAYS CLOSE AND LATCH THE DOOR AFTER THE FIRE IGNITES.**

## 4.5 Maintaining Wood Fires

### 4.5.1 General Advice

Wood burns best in cycles. A cycle starts when a new load of wood is ignited by hot coals and ends when that load has been consumed down to a bed of charcoal about the same size as it was when the wood was loaded. Trying to produce a steady fire by placing a single log at regular intervals is not recommended. Always place at least three, and preferably more pieces on the fire at a time so that the heat radiated from one piece helps to ignite the pieces next to it.



*Prolonged and continuous use at a very low rate of combustion or with very wet wood can cause highly flammable creosote to build up in the flue.*

Burning in cycles means the stove door does not need to be opened while the wood is flaming. This is an advantage since it is preventing smoke leaking from the stove when the door is opened as a full fire is burning. This is especially true if the chimney is on the outside wall of the house.

**If the door must be open while the fire is flaming, fully open the air control for a few minutes then open the door slowly.**

### 4.5.2 Ash Removal

Ash should be removed from the firebox every two to three days. Ash should not accumulate excessively in the firebox since it will affect the proper operation of the cookstove.

The best time to remove ash is when the stove is relatively cold, but there is still a little chimney draft to draw the ash dust into the stove and prevent going out into the room.

Ashes should be placed in a tightly covered metal container. The container must be placed on a non-combustible floor or on the ground well away from all combustible materials.

Ashes can contain hot embers that can stay hot for several days. If the ashes are disposed of by burial in soil or otherwise locally dispersed, they should be kept in the closed metal container until they are completely cooled. No other waste should be placed in this container.

**NEVER STORE ASHES INDOORS OR IN A NON-METALIC CONTAINER OR ON A WOODEN DECK.**

### 4.5.3 Raking Charcoal

When it is time to reload the stove, start by removing the ashes first, then rake charcoal towards the front of the firebox before reloading. Most of the remaining charcoal will be at the back of the firebox, furthest from the door. Rake the coals towards the door before loading.

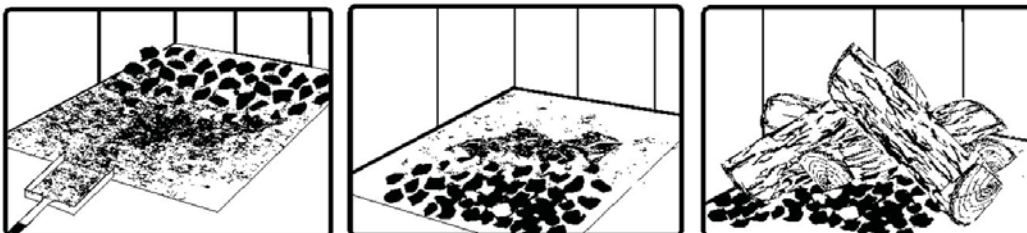

Raking the coals is useful for two reasons. First, it brings them near where most of the combustion air enters the firebox. This will ignite the new load quickly. Secondly, the charcoal will not be smothered by the new load of wood. When the embers are simply spread inside the combustion chamber, the new load smoulders for a long time before igniting.

#### 4.5.4 Firing Each New Load Hot

Place the new load of wood on and behind the charcoal, not too close to the glass. Close the door and open the air control fully until the firebox is full of flames, the wood has charred to black and its edges are glowing red. Firing each load of wood hot accomplishes the following things:

- Removes surface moisture from the wood,
- Creates a layer of char on the wood, which slows down the smoke release,
- Heats the firebox components so they reflect heat back to the fire, and
- Heats the chimney so it can produce strong, steady draft for the rest of the cycle.

Although it is important to fire each new load hot, *do not allow the fire to burn at full intensity for more than a few minutes.*

**THE COOKSTOVE SHOULD NOT BE LEFT UNATTENDED WHILE A NEW LOAD IS BEING FIRED HOT.**

**DO NOT OVERFIRE.**



Overloading the appliance with firewood decreases performance, reduces energy efficiency and accelerates the wear and tear of the appliance. Do not exceed the maximum load of firewood of 7 kg. Overloading the appliance voids all the manufacturer's warranties.

#### 4.6 Adjusting Primary and Secondary Air Inlet

The control of the primary and secondary air inlet is simultaneous and is done with a single regulation control, located under the combustion chamber door.

The optimum regulation of the air inlet can vary according to various factors, such as the chimney flue, the temperature of the cookstove and, the quality of the firewood (moisture, size and shape).

**Do not alter the air regulation control to increase firing for any reason.**



In order to avoid burns while regulating air flow and opening the doors, always use the cold hand provided with the stove.



Figure 5: Cold hand

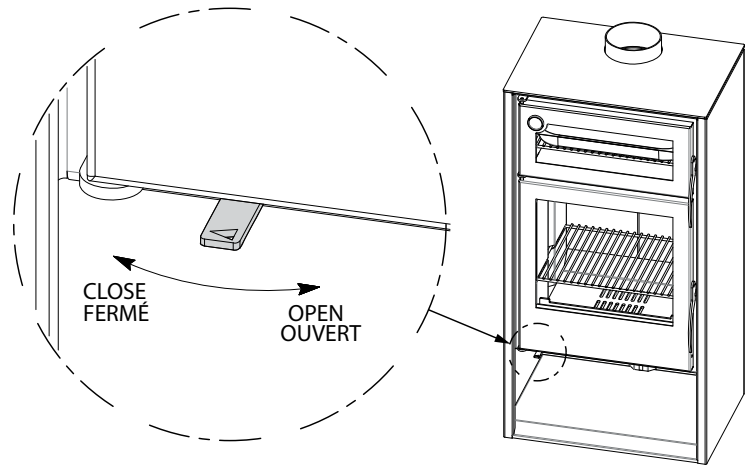

Figure 6: Air inlet control

#### 4.6.1 *Regulating the air during lighting*

Opening the air inlet completely is mandatory during the lighting, and it is recommended to leave the door ajar during lighting as well, in order to avoid condensation of fumes on the glass. Wait enough time (until the hearth has warmed up) before starting to regulate the air inlet.

#### 4.6.2 *Regulating the air during combustion*

Once the device is hot enough, has a good reserve of embers and the flame is well-lit one can regulate the air inlet to achieve good combustion and performance.. The air intake may be regulated to an opening of 15% - 40%. **During the operation of the heater you must not completely close the air inlet.**

## 5. Cookstove Maintenance

This cookstove will give many years of reliable service if used and maintained properly. Some of the internal components of the firebox, such as vermiculite and baffle will wear over time under intense heat. Defective parts should always be replaced with original parts. Firing each load hot to begin a cycle will not cause premature deterioration of the cookstove. However, letting the cookstove run with the air intake fully open for the entire burn cycles can cause damage over time. The hotter the cookstove becomes throughout burn cycles, the more quickly its components will deteriorate. For this reason, **the cookstove should never be left unattended while a new load is being fired hot.**

### 5.1 Cleaning and Painting the Cookstove

Painted surfaces can be wiped down with a soft, dry cloth. If the paint is scratched or damaged, it is possible to repaint it with a heat-resistant paint. **Do not clean or paint the cookstove when it is hot.** Before painting, the surface should be sanded lightly with sandpaper and then wiped off to remove dust. Apply two thin layers of paint. For best results, use the original paint, available in aerosol cans.

It is very important not to wet the wood burner with window-cleaner, water or special cleaning products. Heatproof paint is not waterproof.

### 5.2 Vermiculite Slabs and Baffle

Before installing the slabs and the baffle, ensure that none are broken or damaged in any way, and replace the damaged ones. Check for damage at least annually and replace any broken or damaged ones with new ones.

### 5.3 Combustion Chamber

The cookstove cleaning frequency depends on the type and quality of combustible used. A high humidity rate, ashes, soot, or chemical components in the wood could increase the number of cleanings necessary. Therefore, it is important to pay attention to the combustible used.

To get the maximum performance from the cookstove, ashes should be removed regularly. The use of a personal, central, or commercial vacuum cleaner to clean up the cookstove is not recommended. Ash particles can damage the vacuum engine. Furthermore, hot ashes could ignite the content of the vacuum. The use of a specialized ash vacuum is highly recommended.

The ashes must be stored in a metallic container with a waterproof lid. This closed container should be put on a noncombustible surface, away from any flammable material. If the ashes are meant to be buried or locally dispersed, they should be kept in a closed container until they are completely cold.

### 5.4 Grills and Trays

Clean trays like regular dishes. Clean grills with a brush and soft soap.

### 5.5 Glass Maintenance

Do not clean the glass when the cookstove is hot. To clean the glass, first spray the cleaning product on a cloth and then proceed to clean the glass only, without wetting the rest of the door. Window-cleaners and special products often contain chemicals that attack the paint and the ceramic fibre seals and cause oxidation of the metal parts.

Never use an abrasive cleaner on the window. Do not clean the window when it's hot. Do not force, hit, slam, or do anything that could weaken the glass door. Do not use the cookstove if the window is missing, cracked, or broken.

### 5.5.1 Replacing the Glass Door and the Glass Gasket

The glass used in the this cookstove is 4 mm thick, and was tested to reach temperatures up to 1400° F. It has the following dimensions :

- Oven (W x H): 20" x 13 ⅛"
- Combustion chamber (W x H): 20" x 16"

If the glass breaks, it must be replaced with one having the same specification. Contact your dealer to obtain a genuine replacement part.

**Tempered glass or ordinary glass will not withstand the high temperatures of the cookstove.**

To replace the glass, follow the steps below :

1. Remove the door from its hinges and lay it facing down on a soft surface such as a cloth or a carpet.
2. Remove the screws that holds the brackets in place.
3. Remove the glass.
4. Install the gasket all around the new glass (see image).
5. Reinstall the new glass.

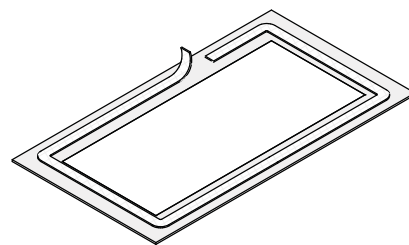

### 5.5.2 Replacing the Door Gasket

To maintain optimal performance, the door should always be perfectly sealed with the combustion chamber. The gasket must be inspected periodically to get a tight seal.

With time, the door gasket will compress and harden which will allow air to infiltrate. You can test the condition of the gasket by closing and locking the door on a piece of paper. Check the periphery of the door. If the paper slides easily at any place around the door, it is time to change the gasket.

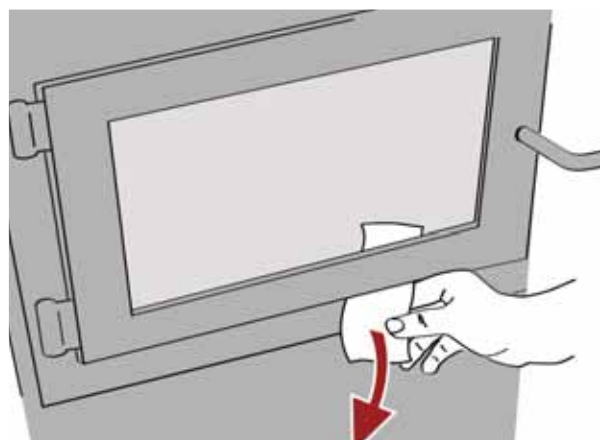

Figure 7: Verifying the door seal

The right diameter and density of the gasket are important to maintain a tight seal. Refer to a dealer for a genuine replacement part. See section "13. Exploded View and Parts List" for more details.

Put the door facing down on a soft surface such as a cloth or a carpet. Remove the gasket and use a screwdriver to scrape away the old adhesive. Apply high temperature sealant in the groove of the gasket. Push the gasket into the groove. Do not stretch the gasket while installing. Keep approximately ½ inch longer when cutting and then push it into the groove. Push away the exceeding fibres under the gasket. Close the door and do not use the cookstove for 24 hours.



## 6. Chimney Maintenance

### 6.1 Why Sweep the Chimney?

Wood smoke can condense inside the chimney and the chimney connector, forming a flammable deposit called creosote. If the creosote builds up in the evacuation system, it can combust when the fire is very hot. An extremely hot fire can progress to the extremity of the chimney. Severe chimney fires can damage even the best chimneys.

Smouldering fires can quickly cause a thick layer of creosote. When those are avoided, the gases coming out of the chimney are almost transparent. Creosote is therefore formed more slowly. Your new cookstove has the necessary characteristics to help you make clean fires producing little or no smoke. Therefore, less creosote will accumulate in the chimney.

### 6.2 Cleaning Frequency

It is not possible to predict how long or how much creosote will form in the chimney. It is important, therefore, to check monthly for deposits in the chimney until the rate of creosote formation is known.

The chimney must be inspected regularly during the heating season to determine if creosote buildup has occurred. If a significant layer of creosote has accumulated (3 mm or more), remove it to reduce the risk of a chimney fire.

Weekly cleaning may be necessary in mild weather, while monthly cleaning may be sufficient in the colder months. Even though creosote is slowly forming in the system, the chimney should be inspected and cleaned at least once a year.

Contact the municipal or provincial fire department for information on how to handle a chimney fire. Have a clearly understood plan for managing a chimney fire.

It is recommended to clean the chimney system at the end of each heating season. During summer, the air is more humid and with minimum air circulation in the appliance, creosote or the soot left in the pipes can produce an acid that will accelerate the corrosion process of steel and may perforate it prematurely. Consequently, this will not be covered by the warranty. Have the chimney system cleaned by a professional sweeper.

### 6.3 Chimney Sweeping

Chimney sweeping can be difficult and dangerous. If you don't have any experience sweeping chimneys, you may want to hire a professional sweeper to inspect and clean your system the first time. After seeing how the sweeping is done, you will know if it is a job you can do yourself.

The most commonly used equipment includes fiberglass rods with threaded connections and plastic brushes. The brush is forcibly moved from top to bottom of the chimney to remove the creosote by rubbing.

The chimney connector and its components should always be cleaned at the same time as the chimney.

When the chimney is clean, open the access panel in front of the cookstove and remove the accumulation of creosote and soot. Also clean accumulation inside the combustion chamber, over the baffle.

## PART B - INSTALLATION

### 7. General Information

#### 7.1 Security

- Read this manual completely before installing the cookstove. It is important to fully respect the installation instructions. If the cookstove is not correctly installed, it could result in a fire, bodily injuries or even death.
- The information given on the certification label affixed to the appliance always overrides the information published, in any other media (owner's manual, catalogues, flyers, magazines and web sites).
- Mixing of appliance components from different sources or modifying components may result in hazardous conditions. Where any such changes are planned, Stove Builder International Inc. Should be contacted in advance. Any modification of the appliance that has not been approved in writing by the testing authority violates CSA B365 (Canada), and ANSI NFPA 211 (USA).
- **DO NOT CONNECT TO OR USE IN CONJUNCTION WITH ANY AIR DISTRIBUTION DUCTWORK UNLESS SPECIFICALLY APPROVED FOR SUCH INSTALLATION.**
- **DO NOT CONNECT THIS UNIT TO A CHIMNEY FLUE SERVING ANOTHER APPLIANCE.**
- Connect this stove only to a listed factory-built chimney for use with solid fuel or to a lined masonry chimney conforming to local and national building codes.
- If required, a supply of combustion air shall be provided to the room.
- Do not use makeshift materials or make any compromises when installing this cookstove.
- **DO NOT INSTALL IN A MOBILE HOME.**

#### 7.2 Regulations Governing the Installation of the Cookstove

In Canada, the CSA B365 Installation Code for Solid Fuel Burning Appliances and Equipment is to be followed in the absence of local code requirements. In the USA, the ANSI NFPA 211 Standard for Chimneys, Fireplaces, Vents and Solid Fuel-Burning Appliances is to be followed in the absence of local code requirements.

This cookstove must be connected to a chimney complying with the requirements for Type HT chimneys in the Standard for Factory-Built Chimneys for Residential Type and Building Heating Appliances, UL 103 HT and ULC S627 or to a code-approved masonry chimney with a flue liner.

#### 7.3 Cookstove Positioning

Choose a location to avoid the chimney conflicting with floor joists, roof trusses, wall studs, water pipes, electric wires, and that allows the least possible deviations in the chimney. The location of the cookstove must allow enough room for its maintenance and the exhaust system.

This cookstove weighs approximately 150 kg (330 lb). To validate the installation of additional floor joist, consult the local building code.

## 7.4 Location of the Certification Label

Since the information given on the certification label affixed to the appliance always overrides the information published, in any other media (owner's manual, catalogues, flyers, magazines and web sites) it is important to refer to it in order to have a safe and compliant installation. In addition, important information about the stove can be found (model, serial number, etc.). The certification label is located on the back of the stove.

It is recommended to note the stove serial number on page 5 of this manual since it will be needed to precisely identify the version of the appliance in the event replacement parts or technical assistance is required. It is also recommended to [register the warranty online](#).

## 8. Clearances to Combustible Materials

The clearances given in this section have been established following test results in accordance with the procedures described in the standards ULC S627 (Canada) and UL 1482 (USA). When this cookstove is installed respecting the indicated minimum clearances or more, the flammable surfaces won't overheat during normal or even abnormal usage.

**None of the cookstove parts or smoke pipe can be installed closer to the combustible materials than the minimum clearances indicated.**

**Fuel, solid or liquid, should not be located closer to combustibles than the minimum clearances given.**

The clearances to the combustible walls can differ slightly between Canada and the United States and can also vary depending on the use of a single wall or double connector. Make sure to use the proper clearances for the location and the type of pipe.

The clearances of the appliance and the flue pipes must be met individually, meaning the appliance can not be installed closer to the combustible materials than the single or double wall pipe allows. Refer to the following images and tables for minimum required clearances

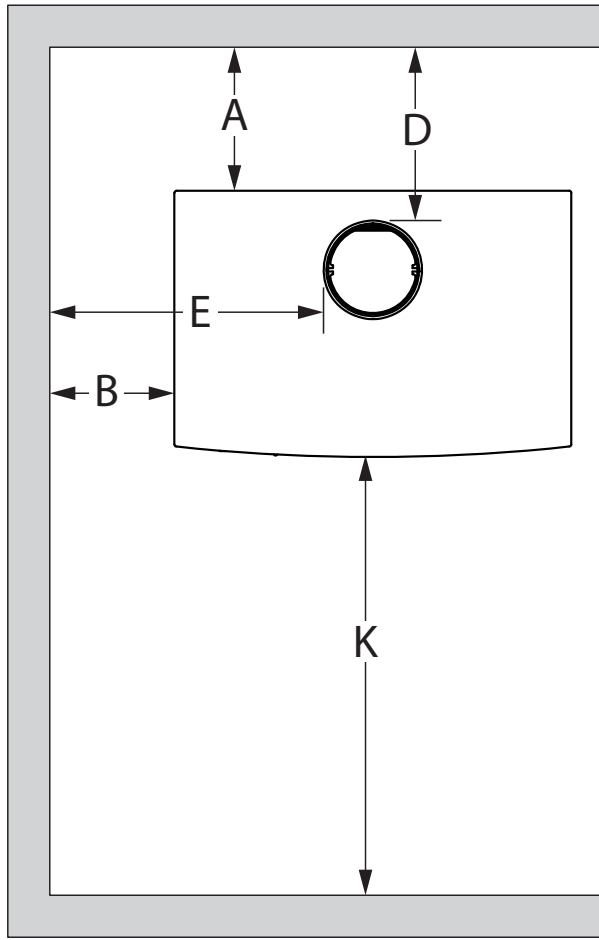

Figure 8: Clearances - Top

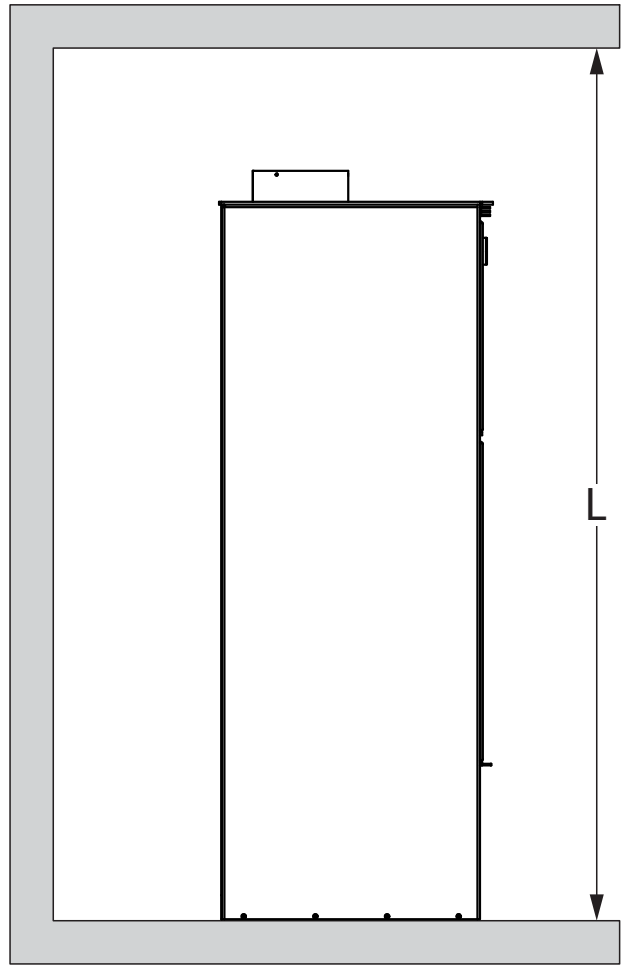

Figure 9: Clearances - Side

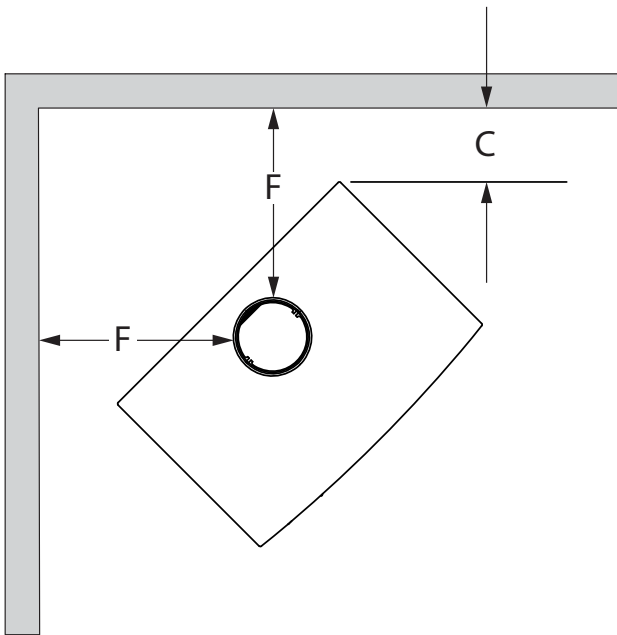

Figure 10: Clearances - Corner

	APPLIANCE CLEARANCES (INSTALLATION WITH SINGLE OR DOUBLE WALL PIPE CONNECTOR)	
	Canada	USA
<b>A</b>	15 ½" (394 mm)	15 ½" (394 mm)
<b>B</b>	13" (330 mm)	13" (330 mm)
<b>C</b>	12" (305 mm)	12" (305 mm)
<b>K</b>	48" (122 cm)	48" (122 cm)
<b>L</b>	84" (213 cm)	84" (213 cm)

	APPLIANCE CLEARANCES (INSTALLATION WITH DOUBLE WALL PIPE CONNECTOR AND HEAT SHIELD AC02762 <sup>1</sup> )	
	Canada	USA
<b>A</b>	2 ½" (64 mm)	2 ½" (64 mm)
<b>B</b>	2 ½" (64 mm)	2 ½" (64 mm)
<b>C</b>	2 ½" (64 mm)	2 ½" (64 mm)
<b>K</b>	48" (122 cm)	48" (122 cm)
<b>L</b>	84" (213 cm)	84" (213 cm)

If the above clearances are met, then the distances measured from the flue outlet will be:

	DISTANCES <sup>2</sup> FROM PIPE CONNECTOR WITH SINGLE WALL PIPE CONNECTOR	
	Canada	USA
<b>D</b>	18" (457 mm)	18" (457 mm)
<b>E</b>	23 ½" (597 mm)	23 ½" (597 mm)
<b>F</b>	21 ½" (546 mm)	21 ½" (546 mm)

	DISTANCES <sup>2</sup> FROM PIPE CONNECTOR WITH DOUBLE WALL PIPE CONNECTOR	
	Canada	USA
<b>D</b>	5" (127 mm)	5" (127 mm)
<b>E</b>	12 ½" (318 mm)	12 ½" (318 mm)
<b>F</b>	12 ½" (318 mm)	12 ½" (318 mm)

### Clearances with heat shield AC02784<sup>1</sup>

Note that to reduce the clearances of an appliance using a single wall pipe connector, the use of a heat shield certified with the single wall pipe connector as well as a heat shield AC02784 to be used as close as 6" from combustible materials must be used. Only in this case, the same clearances as a certified double wall pipe connector can be used.

	APPLIANCE CLEARANCES (INSTALLATION WITH DOUBLE WALL PIPE CONNECTOR)	
	Canada	USA
<b>A</b>	6" (152 mm)	6" (152 mm)
<b>B</b>	13" (330 mm)	13" (330 mm)
<b>C</b>	12" (305 mm)	12" (305 mm)
<b>K</b>	48" (122 cm)	48" (122 cm)
<b>L</b>	84" (213 cm)	84" (213 cm)

	DISTANCES <sup>2</sup> FROM DOUBLE WALL PIPE CONNECTOR	
	Canada	USA
<b>D</b>	8 ½" (216 mm)	8 ½" (216 mm)
<b>E</b>	23 ½" (597 mm)	23 ½" (597 mm)
<b>F</b>	21 ½" (546 mm)	21 ½" (546 mm)

<sup>1</sup> Sold separately. See installation manual for more details.

<sup>2</sup> The pipe distances listed in this table refer to the distances obtained when the cookstove is installed in accordance with the appliance clearances above mentioned.

## Floor Protection

This cookstove is designed to prevent the floor from overheating. However, it must be placed on a non-flammable surface to protect the floor from hot embers that may fall during loading. The floor protection must be a continuous non-combustible surface such as steel with a minimum thickness of 0.015" (0.38 mm), ceramic, concrete board, brick or other equivalent approved material. Ceramic should be placed on a continuous non-combustible board to prevent contact between the cinder and the floor through cracks or gaps in the ceramic grout. See the local code for approved alternatives. No protection is required if the unit is installed on a non-combustible surface (eg concrete floor) See table and figure below.

ENGLISH

**Table 1 : Floor Protection**

	FLOOR PROTECTION	
	Canada	USA
<b>G</b> <sup>1</sup>	8" (203 mm)	N/A
<b>H</b>	8" (203 mm)	N/A
<b>I</b> <sup>2</sup>	18" (457 mm)	16" (406 mm)
<b>J</b> <sup>2</sup>	N/A	8" (203 mm)

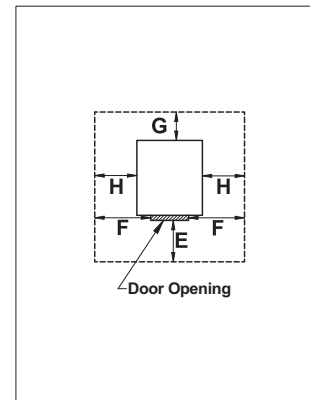

Figure 11: Floor Protection

### 8.1 Clearances Reduction to the Walls and the Ceiling

It is often desired to use as little space as possible when installing cookstove. To do this, it is possible to reduce the clearances safely and install the cookstove closer to the walls by permanently installing a heat shield between the cookstove and the flammable material. Two different heat shields, AC02762 and AC02784, are available to reduce clearances easily and safely.

It is also possible to fabricate the heat shield but one must be careful since the rules for heat shield construction are sometimes complicated. Read and apply the instructions carefully. Some regions may have different regulations. Consult the local building code or contact the fire department for restrictions, inspection and installation requirements in the area.





#### 8.1.1 Heat Shield Construction Rules

- Adhesives used in the shield construction must not inflame or lose their adhesive properties at the temperature that potentially will be reached.
- The assembly hardware must allow for complete vertical ventilation.
- The assembly hardware that penetrates in the combustible material from the screen surface can only be used on the edges of the screen.

<sup>1</sup> In Canada, the floor protection is limited to the back clearance (G) if it is less than 8" (203 mm). In the United States, it is only required under the connected horizontal section and must exceed at least 2" (51 mm) on each side of the connection.

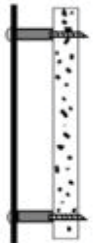
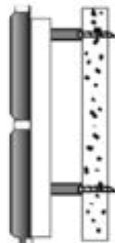
<sup>2</sup> From door opening.

**Table 2 : Clearances Reduction Percentages Table**

TYPE OF SHIELD	CLEARANCES MAY BE REDUCED BY THESE PERCENTAGES				
	SIDES AND REAR		TOP (CEILING)		
	CAN /USA (%)	USA MIN.	CAN /USA (%)	USA MIN.	
Sheet metal, a minimum of 24 gauge (0.61 mm) in thickness , spaced out at least 25 mm (1 in)* by non-combustible spacers	67	12 in	50	18 in	
Ceramic tiles, or equivalent non-combustible material, on non-combustible board spaced out at least 25 mm (1 in)* by non-combustible spacers	50	18 in	33	24 in	
Ceramic tiles, or equivalent non-combustible material, on non-combustible board, with a minimum of 24 gauge (0.61 mm) sheet metal backing spaced out at least 25 mm (1 in)* by non-combustible spacers	67	12 in	50	24 in	
Brick, spaced out at least 25 mm (1 in)* by non-combustible spacers	50	18 in	N/A	N/A	
Brick, with a minimum of 24 gauge (0.61 mm) sheet metal backing, spaced out at least 25 mm (1 in)* by non-combustible spacers	67	12 in	N/A	N/A	

\* In Canada this space can be 21 mm (7/8")

## 8.2 Clearances for Shield Installation

ENGLISH

1	Minimum clearance between the top of the appliance and the unprotected ceiling	925 mm (36 1/2")
2	Shield extension above appliance	500 mm (20")
3	Minimum space behind the shield	USA 25 mm (1") Can. 21 mm (7/8")
4	Clearance at the bottom of the screen	USA 25 mm (1") Can. min. 25 mm (1") max 76 mm (3")
5	Minimum clearance from the top of the screen to the ceiling:	76 mm (3")
6	The assembly hardware must not be located at less than 200 mm (8") from the combustion chamber central axis.	
7	Screen edges clearances from the side and back walls for ceiling screen	75 mm (3")
8	Screen overtaking beyond the sides of the appliance	450 mm (18")

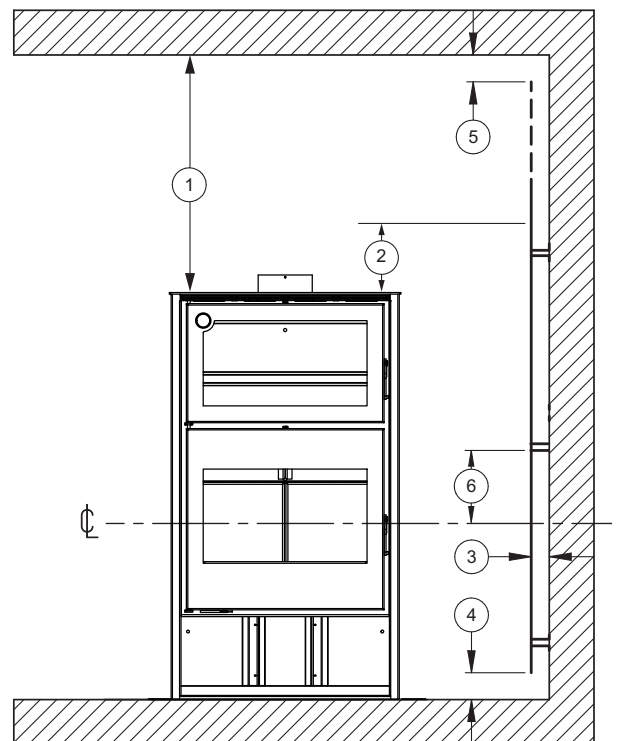
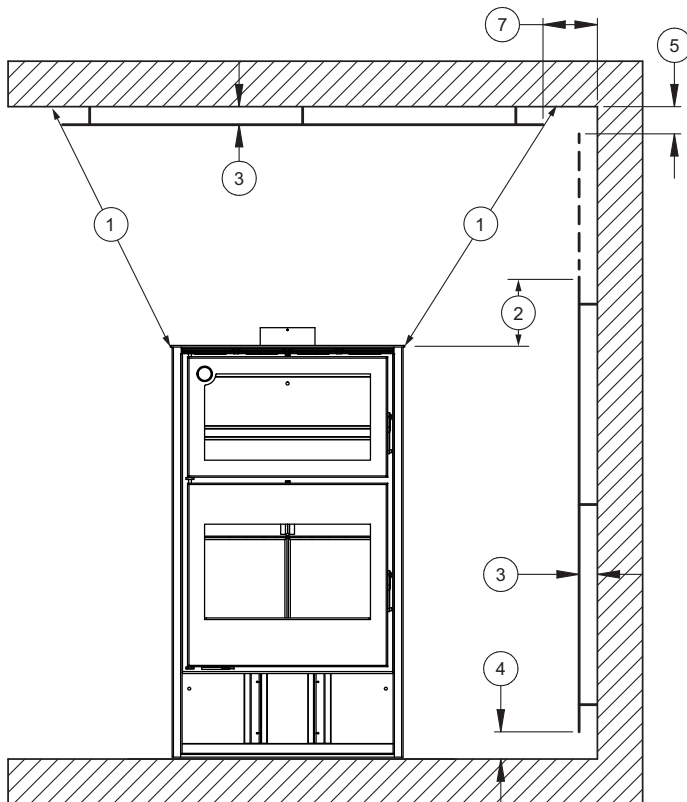
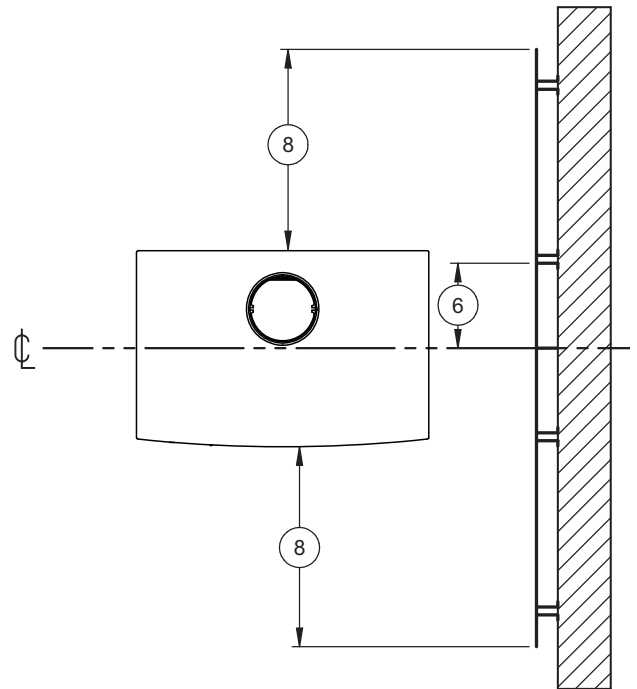



## 9. The Exhaust System

### 9.1 General Information

The exhaust system, consisting of the chimney and the pipe that connects the cookstove to the chimney, acts as the engine that drives the wood heating system. Even the best appliance will not work as securely and adequately as expected if it is not connected to an adequate chimney.

The heat contained in the exhaust gas, which goes from the cookstove to the chimney connector, then to the chimney, is not lost heat. The chimney uses that heat to create the draft that draws the combustion air, keeps the smoke in the appliance and evacuates the gas securely toward open air. You can consider the heat contained in the exhaust gas as the combustible that the chimney uses to create the draft.

### 9.2 Suitable Chimneys

To be suitable, a prefabricated metal chimney must follow the standards UL 103 HT (USA) or ULC S629 (Canada). Furthermore, this wood burning cookstove has a performance and optimal efficiency when it is connected to a 6" chimney flue.

#### 9.2.1 Prefabricated Metal Chimney

These are sometimes referred to as "high temp" chimneys because they have the specific characteristics to withstand the temperatures that can be created by wood burning stoves. Factory-built chimneys are tested as a system with all the necessary components for installation. The instructions provided with the chimney by its manufacturer are the only reliable source of installation guidelines. To be safe and effective, the chimney must be installed exactly in accordance with the manufacturer's instructions. Only components intended for the brand and model of chimney should be used. Never fabricate or substitute parts from other chimney brands. The chimney must be a type suitable for solid fuel.

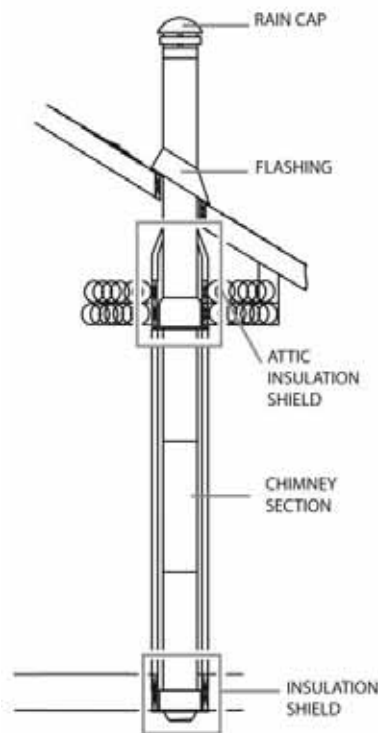

### 9.2.2 Masonry Chimney

The cookstove may also be connected to a masonry chimney, provided the chimney complies with the construction rules found in the building code enforced locally. The chimney must have either a clay liner or a suitably listed stainless steel liner. If the masonry chimney has a square or rectangular liner that is larger in cross sectional area than a round 6" flue, it should be relined with a suitably listed 6" stainless steel liner. Do not downsize the flue to less than 6" unless the venting system is straight and exceeds 25 feet in height. When passing through a combustible wall, the use of an insulated listed thimble is required.

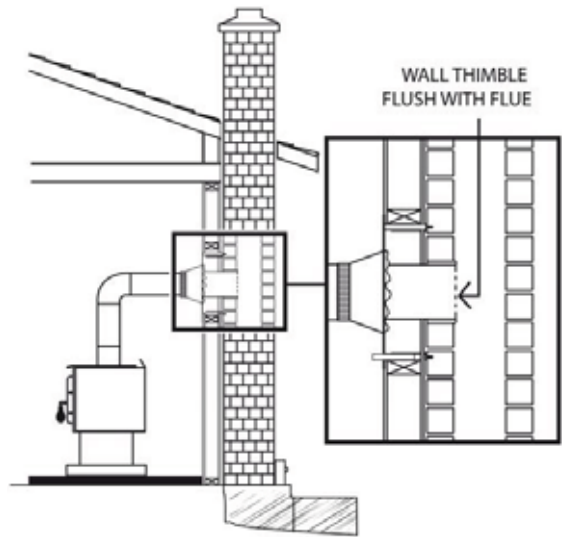

### 9.3 Chimney Height

The chimney top must be high enough to overcome air turbulence caused by the wind blowing around the house and over the roof. The chimney must exceed by at least 1 meter (3 ft.) its highest exit point from the roof and by at least 60 cm (2 ft.) for any part of the roof or any obstacle located at a horizontal distance of at least 3 m (10 ft.).

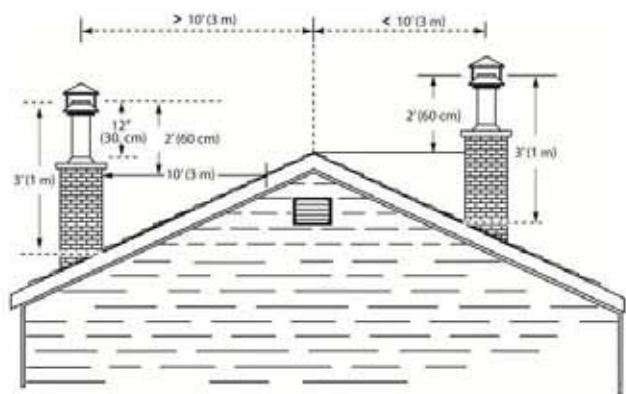
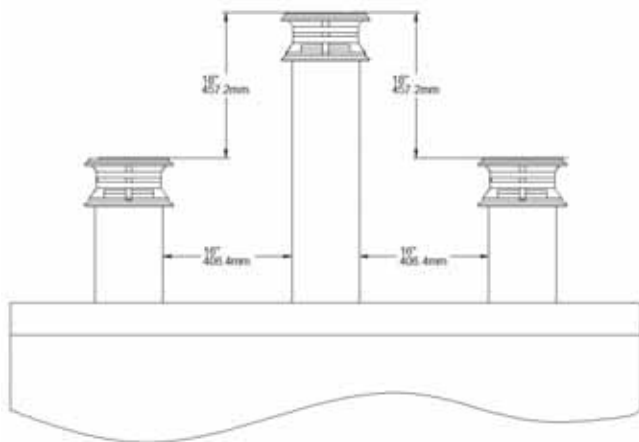

## 10. Combustion Air Supply

For the cookstove draft to work correctly, the room must have an outside or fresh air inlet, with a minimum of 4" diameter, from the house exterior to the room, that is at least sufficient to replenish the volume of air that comes out of the chimney flue. In well insulated houses an air inlet must be fitted through the outer wall that is not exposed to the prevailing winds, depending on the surrounding conditions of the house. If a vent is installed, it must be fitted in such a way that it cannot be blocked.

The outdoor air must be routed through a duct no more than 300 mm (12") away from the appliance, in order not to interfere with its operation. A watertight mechanical valve will close the air inlet when the cookstove is not used. Protection against rodents must be installed on external edge.

When the cookstove and the chimney are completely cold, it may be necessary before starting up to provide an external air supply by opening a door or a window for a short period. A house constructed or renovated in a waterproof manner is prone to not having the air exchange required for the proper functioning of a wood heating appliance.

In that case, avoid, during startups, to use appliances that evacuate air outside of the house, such as:

- Cookstove hood
- Bathroom vent
- Air exchange system
- Ventilated central vacuum cleaner
- Dryer

The supply of fresh combustion air can be done in several ways, provided they comply with CSA B365 and NFPA211.

## 11. Chimney Connector Installation

The chimney connector is the single or double wall pipe, installed between the cookstove and the chimney. The components of the single wall pipe are sold in most hardware or construction supply stores. These sections usually do not comply with a precise standard and are not certified. Consequently, several rules found in the heating appliance installation codes are applied to the installation of the single wall pipe.

The double wall chimney connectors have gone through testing and are certified. The rules for double wall pipes are found in the manufacturer's installation guide. These rules are very different from the single wall pipes.

### 11.1 Single Wall Chimney Connector Installation

The entire chimney connector has been called "the weak link" in the security of the wood heating system because if the connector is not properly installed, it can provoke a fire.

The best smoke pipe installation goes straight from the cookstove to the base of the chimney with no elbow. Straight installation will cause fewer problems such as smoke returns when the door is open to reload the appliance. They are also more stable and easier to maintain than installations with elbows. Avoid, as much as possible, horizontal smoke pipes sections because they reduce the chimney draft and are more conducive to creosote accumulation.

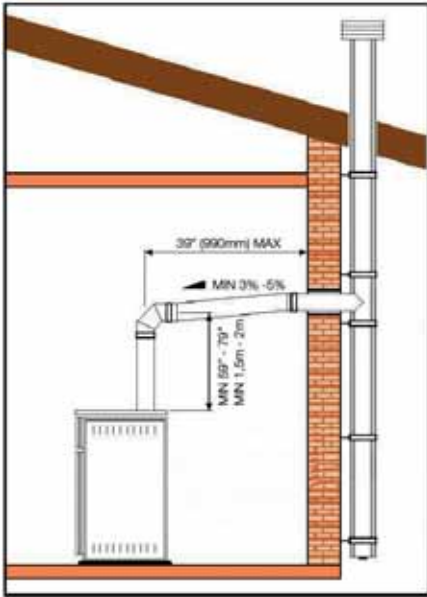

Vertical or horizontal installation, prefabricated exterior chimney

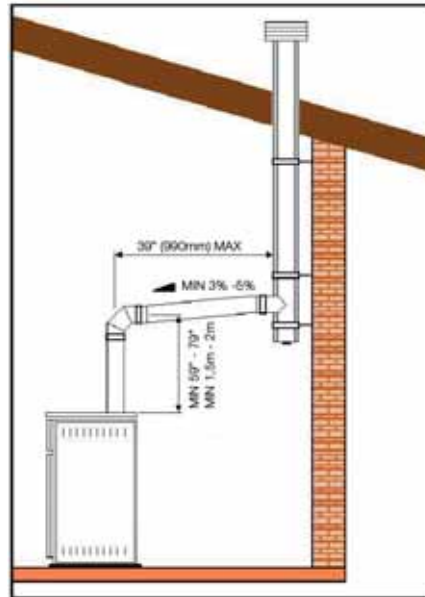

Vertical installation, prefabricated interior chimney

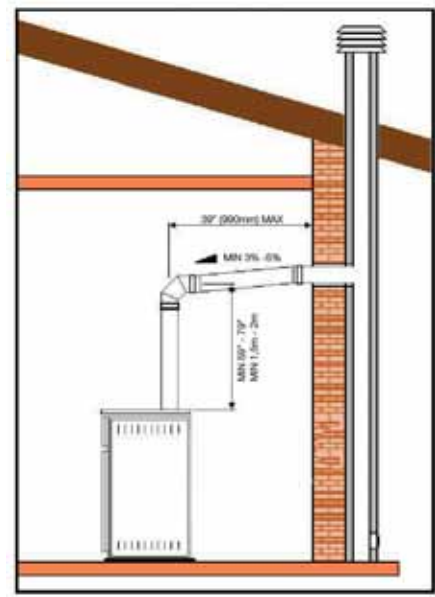

Vertical or horizontal installation, masonry exterior chimney

The rules below are based on the rules found in the installation code of a solid fuel burning appliance. It is imperative to carefully follow these installation instructions or those of the local code.

- An ideal pipe installation is the one that goes straight from the cookstove directly into the chimney, without elbows. A straight installation requires either a telescopic section or a coupling pipe so it can be mounted or dismantled without having to move the cookstove. A straight pipe installation offers the minimum amount of restriction to the exhaust of the smoke and gives a better draft. Straight installations also need less maintenance because there are no angles where creosote can be deposited.
- The maximum length of the horizontal pipe is 3m (10 ft.) including the elbows.
- The minimum clearance in relation to combustible materials is : 450 mm (18"). The minimum clearance can be reduced if an appropriate heat shield is installed. See the heat shield installation instructions for more details.
- The pipe between the cookstove and the chimney must be as short and straight as possible. It is often better to use two 45° elbows instead of one 90° elbow.
- The maximum number of 90° elbows is two.
- The maximum unsupported horizontal length is 1m (3 ft.)
- Galvanized smoke pipes must not be used because their coating vaporizes itself at high temperature and produces dangerous gas. Use black smoke pipes.
- Flue pipes must have a thickness of at least 24 ga.
- Flue pipe connectors must overlap at least 30 mm (1 ¼")
- Each installation connector must be fixed with at least three screws.

- The installation must be able to expand: the installation of elbows allow expansion; straight installations must have a coupling pipe with an extremity without attachment or with a telescopic section.
- Minimum upward slope toward the chimney: 20 mm/m (1/4" per foot)
- One of the installation extremities must be firmly fixed to the cookstove nozzle with three metal screws and the other extremity firmly fixed to the chimney.
- It must be possible to clean the pipes either by a manhole or by removing the pipes. The removal of the pipes must not require moving the cookstove.
- The male parts of the pipe sections must be toward the appliance so the ashes and the condensation stay inside the pipe.
- A chimney connector shall not pass through an attic or roof space, closet or similar concealed space, or a floor, or ceiling. Where passage through a wall, or partition of combustible construction is desired, the installation shall conform to CAN/CSA-B365, Installation Code for Solid-Fuel-Burning Appliances and Equipment
- The chimney connector must be in good condition and kept clean.

## 12. Troubleshooting

PROBLEM	POSSIBLE CAUSES	SOLUTION
Oven window or combustion chamber's window blackening.	<ul style="list-style-type: none"> <li>• Draft too low</li> <li>• Bad air intake adjustment</li> <li>• Too much combustible in the cookstove.</li> <li>• Wood with a high rate of relative humidity &gt; 20-25%</li> <li>• Unregulated combustion.</li> </ul>	<ul style="list-style-type: none"> <li>• Check that all the pipes are clean.</li> <li>• Modify the chimney: increase the height or check surroundings.</li> <li>• Reduce the quantity of combustible in the combustion chamber.</li> <li>• Dry the wood longer.</li> </ul>
Irregular draw.	<ul style="list-style-type: none"> <li>• Inadequate or dirty chimney.</li> <li>• Dirt in the combustion chamber or in the cookstove.</li> <li>• Strong winds</li> </ul>	<ul style="list-style-type: none"> <li>• Sweep the chimney or have it clean by a professional.</li> <li>• Clean the cookstove.</li> <li>• Relocate chimney or fresh air intake.</li> </ul>
Black smoke leaking out of the cookstove.	<ul style="list-style-type: none"> <li>• Ignition with green wood.</li> <li>• Smoke pipe obstructed.</li> </ul>	<ul style="list-style-type: none"> <li>• Ignite the cookstove with suitable combustible.</li> <li>• Ask for professional qualified assistance.</li> </ul>
Smoke coming out of the cookstove.	<ul style="list-style-type: none"> <li>• Combustion chamber's door open while the cookstove is heating.</li> <li>• Insufficient draw</li> <li>• Bad adjustments of the air inlets during startup.</li> <li>• The cookstove must be cleaned.</li> </ul>	<ul style="list-style-type: none"> <li>• Check the door closing and the tightness of the gaskets.</li> <li>• Check the chimney system.</li> <li>• Eliminate or reduce to minimum the deviations and horizontal lengths in the chimney.</li> <li>• Check all the chimney sections as well as its height on the outside.</li> <li>• Ask for a chimney inspection by a certified technician.</li> <li>• Regularly clean the cookstove as indicated.</li> </ul>

# 13. Exploded View and Parts List

ENGLISH

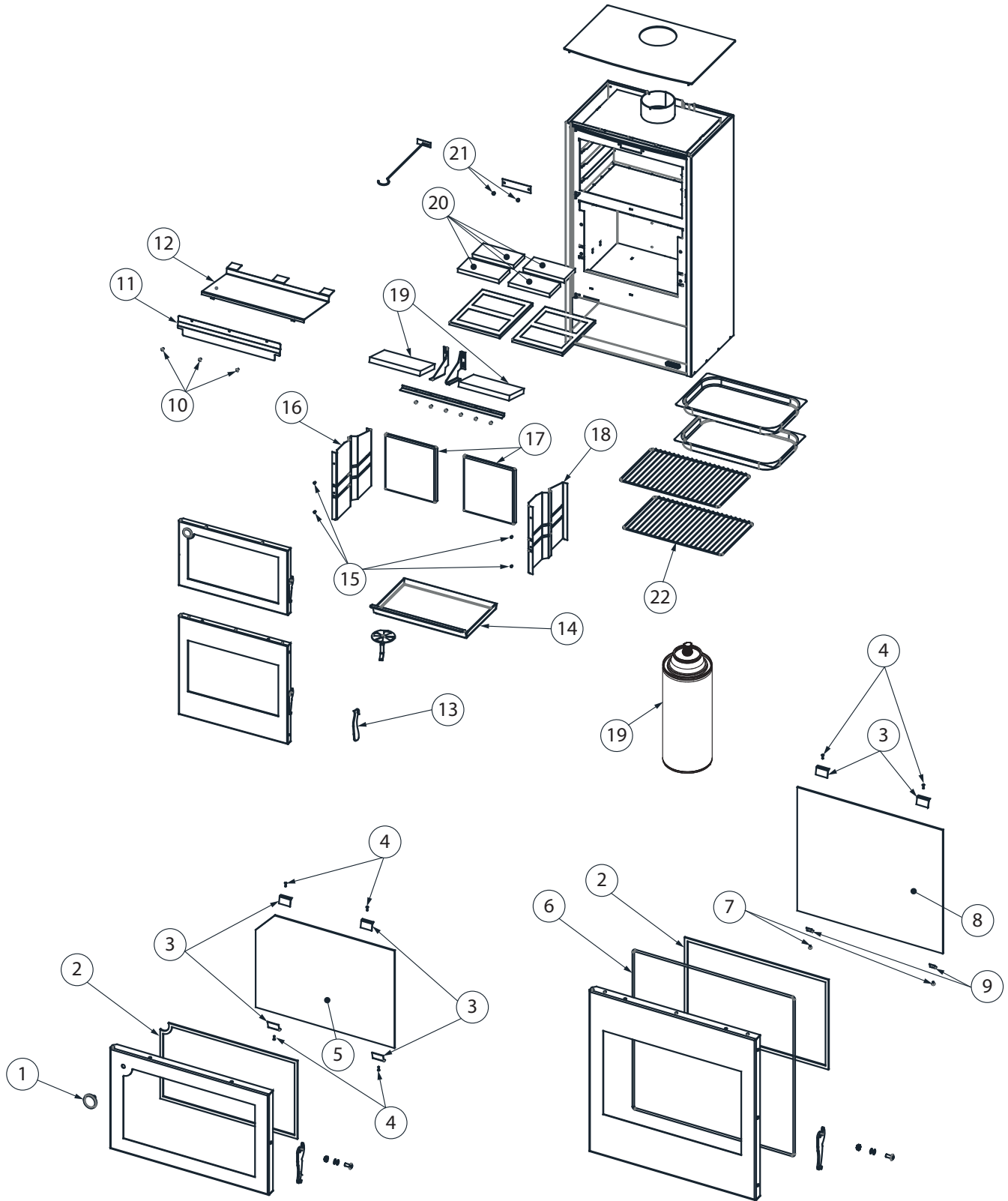

IMPORTANT: THIS IS DATED INFORMATION. When requesting service or replacement parts for your unit, please provide the model number and the serial number. We reserve the right to change parts due to technology upgrade or availability. Contact an authorized dealer to obtain any of these parts. Never use substitute materials. Use of non-approved parts can result in poor performance and safety hazards.

#	Item	Description	Qty
1	31040	Thermometer	1
2	AC06400	3/4" (Flat) x 6' black self-adhesive glass gasket	2
3	31041	Glass support	6
4	23082	Over glass	1
5	AC06705	Glue and 1/4" x 7' white door gasket kit	1
6	23083	Combustion chamber glass	1
7	31042	Small glass support	2
8	31039	Front baffle support	1
9	31034	Stainless steel baffle	1
10	31036	Cold hand	1
11	31033	Fire grate	1
12	31035	Stainless steel left combustion chamber panel	1
13	21531	Vermiculite back board	2
14	31038	Stainless steel right combustion chamber panel (	1
15	21532	Vermiculite baffle	2
16	21533	Refractory brick	4
17	31043	Cleaning access panel blind screw	2
18	31037	Cooking grill	2
19	42054	Grey stove paint - 400 ml aerosol	1



# ATLAS COOKING STOVE LIMITED LIFETIME WARRANTY

The warranty of the manufacturer extends only to the original retail purchaser and is not transferable. This warranty covers brand new products only, which have not been altered, modified nor repaired since shipment from factory. Proof of purchase (dated bill of sale), model name and serial number must be supplied when making any warranty claim to your DROLET dealer.

**This warranty applies to normal residential use only. Damages caused by misuse, abuse, improper installation, lack of maintenance, over firing, negligence or accident during transportation, power failures, downdrafts, venting problems or under-estimated heating area are not covered by this warranty. The recommended heated area for a given appliance is defined by the manufacturer as its capacity to maintain a minimum acceptable temperature in the designated area in case of a power failure.**

This warranty does not cover any scratch, corrosion, distortion, or discoloration. Any defect or damage caused by the use of unauthorized or other than original parts voids this warranty. An authorized qualified technician must perform the installation in accordance with the instructions supplied with this product and all local and national building codes. Any service call related to an improper installation is not covered by this warranty.

The manufacturer may require that defective products be returned or that digital pictures be provided to support the claim. Returned products are to be shipped prepaid to the manufacturer for investigation. Transportation fees to ship the product back to the purchaser will be paid by the manufacturer. All parts covered by this warranty are limited according to the table below.

The manufacturer, at its discretion, may decide to repair or replace any part or unit after inspection and investigation of the defect. The manufacturer may, at its discretion, fully discharge all obligations with respect to this warranty by refunding the wholesale price of any warranted but defective parts. The manufacturer shall, in no event, be responsible for any uncommon, indirect, consequential damages of any nature, which are in excess of the original purchase price of the product. A one-time replacement limit applies to all parts benefiting from lifetime coverage. This warranty applies to products purchased after March 1<sup>st</sup>, 2015.

DESCRIPTION	WARRANTY APPLICATION*	
	PARTS	LABOUR
Combustion chamber (welds only) and cast iron door frame.	Lifetime	N/A
Surrounds, ash drawer, trims (extrusions), and convector air-mate.	5 years	N/A
Removable stainless steel combustion chamber components, deflectors, and supports.	5 years	N/A
Glass retainers, handle assembly, and air control mechanism.	3 years	N/A
Carbon steel combustion chamber components.	2 years	N/A
Paint (peeling**), plating (defective manufacture**), ceramic glass (thermal breakage only**), gaskets, insulation, and oven thermometer.	1 year	N/A
Firebricks, vermiculite combustion chamber components, oven mitt, and cooking accessories.	N/A	N/A
All parts replaced under the warranty.	90 days	N/A

*\*Subject to limitations above. \*\*Picture required.*

Shall your unit or a components be defective, contact immediately your **DROLET** dealer. To accelerate processing of your warranty claim, make sure to have on hand the following information when calling:

- Your name, address and telephone number;
- Bill of sale and dealer's name;
- Installation configuration;
- Serial number and model name as indicated on the nameplate fixed to the back of your unit;
- Nature of the defect and any relevant information.

**Before shipping your unit or defective component to our plant, you must obtain an Authorization Number from your DROLET dealer. Any merchandise shipped to our plant without authorization will be refused automatically and returned to sender.**





This document is available for free download on the manufacturer's website. It is a copyrighted document. Resale is strictly prohibited. The manufacturer may update this document from time to time and cannot be responsible for problems, injuries, or damages arising out of the use of information contained in any document obtained from unauthorized sources.



Stove Builder International inc.  
250, rue de Copenhague,  
St-Augustin-de-Desmaures (Québec) Canada  
G3A 2H3  
418-908-8002  
[www.drolet.ca/en/](http://www.drolet.ca/en/)  
[tech@sbi-international.com](mailto:tech@sbi-international.com)