



COUNTRY FLAME TECHNOLOGIES

INSTALLATION, OPERATION AND MAINTENANCE MANUAL

MODEL CF-04 CROSSFIRE STOVE FIREPLACE INSERT, (CORN FUEL VERSION)

USA & CANADA TEST:
ASTM E 1509-03, ULCS627-M90
ULCS628-M92, UL 1482,
Oregon Administrative Rules 814-23-900 thru 909

TESTED BY:
WARNOCK HERSEY



MOBILE HOME APPROVED



WARNING: If the directions in this manual are not followed exactly, a fire may result causing property damage, personal injury or loss of life.

FOR YOUR SAFETY

Do not store or use gasoline or other flammables (vapor or liquids) in or around the vicinity of this appliance.

Installation and repair must be performed by a qualified service agency.

Always check with local jurisdiction or code agency before installing this product. Local jurisdiction may be requiring a permit prior to installation.

© 2006

COUNTRY FLAME

Country Flame Technologies
A Division of American Products, LLC

900 George Street
Marshfield, MO 65706
417-859-0990 phone
417-859-0192 fax

www.countryflame.com

Version 2.0fc

SAFETY NOTES

The Crossfire Model CF-04 CORN fuel stove is significantly different from a conventional wood-burning stove. One major difference is that the CF-04 requires a reliable source of electrical energy to properly operate. **The owner, installer, and operator must understand this manual and read it in its entirety. Understanding this manual should be completed and followed before installation or operation of the CF-04 is attempted.** Failure to follow installation and operation instructions or perform necessary maintenance can result in property damage, bodily injury, or even death. Country Flame strongly recommends that a certified professional install the Crossfire Model CF-04.

WARNING: **THE AUTHORITY HAVING JURISDICTION** (such as a municipal building department, fire department, or fire prevention bureau, etc) **SHOULD BE CONSULTED BEFORE BEGINNING INSTALLATION. A PERMIT MAY BE REQUIRED IN ORDER TO PERFORM INSTALLATION.**

WARNING: A smoke detector is recommended to be installed in the vicinity of the Crossfire CF-04.

WARNING: Country Flame Technologies has no control over installation or maintenance procedures; therefore, Country Flame grants no warranty, implied or written, for the installation or maintenance of the CF-04. Further, Country Flame assumes no responsibility for any consequential damage resulting from said installation or maintenance of this product.

WARNING: After operation, always allow the Crossfire stove to completely cool before performing any maintenance operations.

WARNING: The Crossfire stove requires reliable electric energy to properly operate. If electrical power is not available, **DO NOT** operate the Crossfire with only a natural draft.

WARNING: Only a certified professional should install a Crossfire stove. Only a qualified service technician should perform maintenance on the Crossfire. Parts removed for installation or servicing must be replaced prior to operational use of this stove.

WARNING: Modification of the Crossfire is not authorized and any modification to the Crossfire voids Country Flame's product warranty.

WARNING: The Crossfire must be connected to a code compliant grounded 120-volt, 15 ampere, and 60 hertz electrical outlet. Use of a dedicated circuit is recommended. **NEVER** use an adapter, extension cord or cut or remove any prong from the power cord.

WARNING: **NEVER** place or store any combustible or flammable products on or near the Crossfire.

WARNING: The Crossfire is designed to shutdown in the event the front door is opened. Keep the viewing door tightly closed during operation. Always clean the Crossfire after the stove has been allowed to return to normal room temperature.

WARNING: Do not connect the Crossfire to a chimney flue serving another stove of any type and never install a flue damper in the exhaust system of the Crossfire.

WARNING: **FOLLOW** all operating instructions in this manual. Short cuts in operating procedures, of any kind, can be dangerous.

- WARNING:** Maintain all minimum safety clearances of the Crossfire stove and chimney system. Never install the Crossfire in a sleeping room.
- WARNING:** The Crossfire-Corn is designed and approved for burning of number 2 yellow shelled corn with a maximum moisture content of 14% (10%-12% recommended) or industry approved wood pellet fuel. Any fuel used in this stove must meet or exceed APFI standards. Do not burn untested fuels or foreign materials in this product. Failure to comply with fuel restriction voids Country Flame's warranty and the safety listing of the unit. Poor quality fuel will directly (*and adversely*) affect efficiency and cleanliness of operation. Country Flame's local authorized dealer can help in recommending a quality fuel
- WARNING:** **NEVER** use gasoline, lantern fuel, kerosene, charcoal lighter fluid or other combustible liquids to start or "freshen up" the fire in this product. Do not store or use gasoline or other flammable liquids or allow combustible vapors in the vicinity of product.
- WARNING:** **NEVER** put foreign objects in the hopper and **NEVER** burn trash or unapproved material in the Crossfire. Using fuels other than #2 shelled corn or premium hardwood pellet mixed with corn voids the Country Flame warranty. Damage to the stove resulting from foreign objects is not covered by warranty.
- WARNING:** Ensure free and adequate airflow to and around the Crossfire. This stove is a combustion system that requires continuous flow of fresh air for proper operation. Failure to provide an adequate fresh air supply can lead to operational problems such as: negative pressure in the home, poor operation of this or other home combustion appliances, or a host of other issues. Remember that other combustion appliances in the home compete for fresh air. Consult with a professional to ensure positive air flow is provided to the stove during operation.
- WARNING:** The Crossfire's exhaust system works with a negative combustion chamber pressure and a low positive chimney pressure. It is very important that the Crossfire's exhaust system be airtight and properly installed. All exhaust joints connected to the Crossfire or each flue section is to be sealed. Use 500 degrees Fahrenheit (500^oF or 260^oC) silicone sealant or aluminum high temperature tape and secure each joint with (3) sheet metal screws. An improperly installed stove or chimney system is the major cause of home fires.
- WARNING:** When installed in a mobile home, the Crossfire must be electrically grounded to the steel chassis of the mobile home. In addition, the stove must be bolted to **A NON-COMBUSTABLE FLOOR floor**. A mobile home installation of the Crossfire should be in accordance with the Manufactured Home and Safety Standard (HUD), CFR 3280, Part 24. Consult the local code authority.
- WARNING:** **SOOT AND FLY ASH:** The products of combustion will contain small particles of fly ash. The fly ash will collect in the exhaust venting system and restrict the flow of the flue gases. Incomplete combustion, such as occurs during start-up, shut down, or incorrect operation of the Crossfire will lead to soot formation in the exhaust venting system. Use the Crossfire cleanout ports to clean the exhaust venting system at least twice every year.
- WARNING:** **ASH REMOVAL:** The ash should be emptied every day or as required to ensure proper operation. If the ash compartment is not emptied regularly, ash will build up and restrict the flow of fresh air in the combustion chamber. The airtight seal of the viewing door ensures a proper combustion process per the stove design and it should not be open during normal operation of the stove.

CAUTION: Operate the Crossfire with the fuel hopper lid closed at all times. Failure to keep the hopper lid closed during operation may result in the release of combustion gasses into the home from the hopper under certain conditions. Maintain the Crossfire hopper seal in good condition and do not overfill the hopper.

CAUTION: The stove controls the rate of fuel fed into the fire pot. Never do anything to overfeed fuel or cause over firing of the Crossfire.

CAUTION: **THE CROSSFIRE IS HOT WHILE IN OPERATION. DO NOT TOUCH. KEEP CHILDREN, CLOTHING, AND FURNITURE AWAY. CONTACT WITH HOT SURFACES MAY CAUSE SEVERE SKIN BURNS. REFER TO THE SAFETY LABEL FOR INSTRUCTIONS.**

NOTE: **RETAIN** this **MANUAL** for future reference as needed. Ensure the manufactured date and serial number of the Crossfire are written down for use should maintenance be required.

EPA STANDARDS

The Country Flame Crossfire meets rigorous emission standards. All Country Flame Crossfire Model CF-04 stoves conform to United States Environmental Protection Agency standards.

LISTING/TESTING AGENCY

The Crossfire Model CF-04 has been independently tested and listed in accordance with ASTM E1509-03, ULCS627-M90, ULCS628-M92, UL 1492 standard and Oregon Administrative Rules 814-23-900 – through 909. This listing is for installation into residential dwellings, including standard construction units, mobile home units, or modular home units. The Crossfire Model CF-04 was tested to UL standards by Intertek Testing Services, NA, Inc., 8431 Murphy Drive, Middleton, WI 53562.

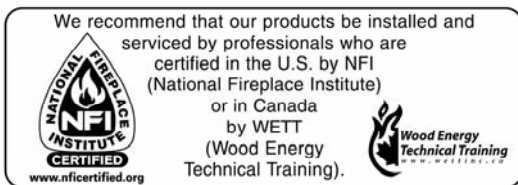

CERTIFICATION SAFETY LABEL (sample)



**LISTED MULTI-FUEL BURNING SPACE HEATER/FIREPLACE INSERT
ALSO SUITABLE FOR MOBILE HOME INSTALLATION
MODEL NAME: CROSSFIRE**

MODEL: CF-04

SERIAL # XXXX

THIS APPLIANCE HAS BEEN TESTED BY
WARNOCK HERSEY, INC IN ACCORDANCE
WITH ASTM E1509, U1482, ULCS627, ULC S628,
AND OREGON ADMINISTRATIVE RULES 814-23-900
THRU 909 FOR PELLET FUEL HEATERS

**MANUFACTURED BY: COUNTRY FLAME TECHNOLOGIES
A DIVISION OF AMERICAN PRODUCTS, LLC
900 GEORGE STREET
MARSHFIELD, MISSOURI 65706**

**INSTALL AND USE IN ACCORDANCE WITH ALL MANUFACTURE'S INSTALLATION AND OPERATING INSTRUCTIONS.
CONTACT LOCAL BUILDING OR FIRE OFFICIALS ABOUT LOCAL RESTRICTIONS AND INSTALLATION INSPECTIONS.**

**A 4" TYPE "PL" VENTING SYSTEM OR A LISTED TYPE "L" CHIMNEY IS TO BE USED WITH THIS PRODUCT. REFER TO
THE LOCAL BUILDING CODE AND THE APPLIANCE AND VENT MANUFACTURER'S INSTRUCTIONS FOR PRECAUTIONS
REQUIRED FOR PASSING VENTING SYSTEM COMPONENTS THROUGH A COMBUSTIBLE WALL OR CEILING.**

**OPERATE UNIT ONLY WITH DOORS FULLY CLOSED
REPLACE GLASS ONLY WITH APPROVED CERAMIC GLASS
START STOVE BY PUSHING ON/OFF SWITCH
STOP STOVE BY PUSHING ON/OFF SWITCH**

**THIS APPLIANCE QUALIFIES AS A NON-AFFECTED FACILITY ACCORDING TO
U.S. ENVIRONMENTAL PROTECTION AGENCY**

CAUTIONS

**WARNING: DO NOT INSTALL IN A
MOBILE HOME SLEEPING ROOM.**

**FOR USE WITH SHELLED CORN OR
PELLETIZED WOOD FUEL
USE OF OTHER FUELS MAY DAMAGE UNIT
AND CAUSE HAZARDOUS CONDITIONS.**

**DO NOT CONNECT THIS
UNIT TO A CHIMNEY
SERVING ANOTHER
APPLIANCE.**

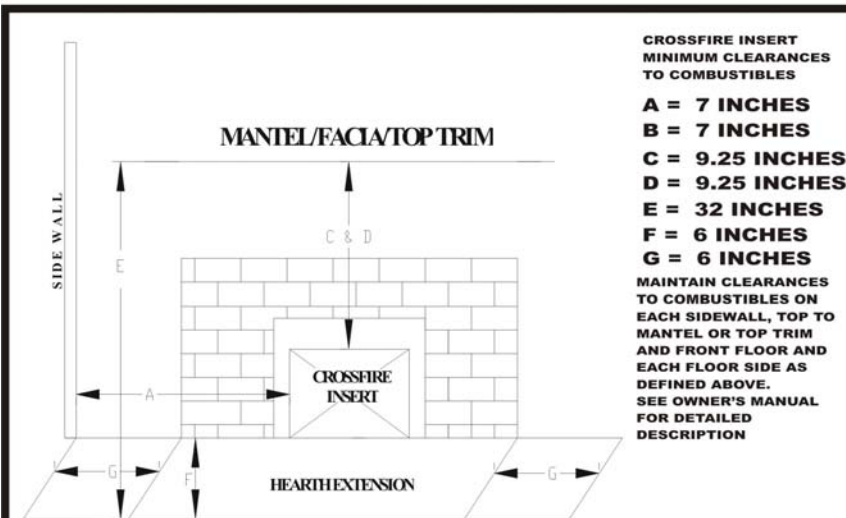

**ONLY OPERATE THE CROSSFIRE WITH FUEL HOPPER LID CLOSED. FAILURE TO DO SO MAY
RESULT IN EMISSION OF PRODUCTS OF COMBUSTION FROM THE FUEL HOPPER UNDER
CERTAIN CONDITIONS. MAINTAIN HOPPER SEAL IN GOOD CONDITION. DO NOT OVERFILL.**

**ELECTRICAL REQUIREMENTS
120 VOLTS 4 AMPS 60 HZ
ROUTE POWER CORD AWAY FROM UNIT**

**INPUT RATING
5.9 LBS/HR**

**CAUTION: MOVING PARTS MAY CAUSE INJURY.
DO NOT OPERATE WITH SHROUD REMOVED.**

**CAUTION: HOT PARTS. DO NOT
OPERATE WITH SHROUD REMOVED.**

**DANGER: RISK OF ELECTRIC SHOCK.
DISCONNECT POWER BEFORE SERVICING UNIT**

'04 '05 '06 '07 JAN FEB MAR APR MAY JUN JUL AUG SEP OCT NOV DEC

MADE IN U.S.A.

TABLE OF CONTENTS

SAFETY NOTES.....	2
EPA STANDARDS	4
LISTING/TESTING AGENCY	4
CERTIFICATION SAFETY LABEL (sample)	5
TABLE OF CONTENTS.....	6
FORWARD.....	8
COUNTRY FLAME	8
CROSSFIRE LIMITED WARRANTY	9
CROSSFIRE LIMITED WARRANTY (continued).....	10
THE CROSSFIRE OPERATION	12
FEATURES	12
SAFETY FEATURES	13
BATTERY BACKUP SYSTEMS	13
FUEL REQUIREMENTS	14
CROSSFIRE STARTUP	15
ASH REMOVAL	18
<i>Intelli-Choice</i> CONTROL BOARD	18
CONTROL BOARD FACE ILLUSTRATION	20
CONTROL BOARD TROUBLESHOOTING CODES	23
STOVE ELECTRICAL DIAGRAM	25
STOVE SPECIFICATIONS	26
ELECTRICAL REQUIREMENTS.....	26
GOLD DOOR CARE	26
OPTIONAL FEATURES.....	26
OPTIONAL THERMOSTAT OPERATION.....	26
CROSSFIRE IS COLD	26
CROSSFIRE IS HOT	26
CHANGE HEAT LEVEL (thermostat active).....	26
CHANGE HEAT LEVEL (thermostat inactive).....	27
COMBUSTION FRESH AIR CONTROL	27
INSTALLATION	28
INSTALLATION PREPARATION	28
STOVE CLEARANCES	28
SHROUD INSTALLATION.....	29
CHIMNEY	30
FACTORY-BUILT CHIMNEY.....	30
MASONRY BUILT CHIMNEY.....	30
FLOOR PROTECTION REQUIREMENTS	31
OUTSIDE AIR COMBUSTION.....	32
MOBILE HOME INSTALLATION	33

MOBILE HOME RULES	33
MOBILE HOME CLEARANCES.....	33
MOBILE HOME STOVE ATTACHMENT.....	34
MOBILE HOME FLOOR PROTECTION.....	34
MOBILE HOME CHIMNEY AND DUCTS.....	35
MAINTENANCE REQUIREMENTS	38
GENERAL REQUIREMENTS.....	38
STOVE DOOR INSTALLATION.....	38
STOVE DOOR ADJUSTMENT.....	39
STOVE DOOR GLASS CLEANING.....	39
GLASS REPLACEMENT	39
GLASS-CERAMIC SPECIFICATIONS	40
GASKET REPLACEMENT	40
CROSSFIRE CLEANING	40
APPENDIX A: TROUBLESHOOTING GUIDE.....	43
APPENDIX A: TROUBLESHOOTING GUIDE (CONT'D)	44
APPENDIX B: MAINTENANCE GUIDE.....	45
APPENDIX B: MAINTENANCE GUIDE (CONT'D)	46
APPENDIX B: MAINTENANCE GUIDE (CONT'D)	47
APPENDIX C: TECHNICAL SPECIFICATIONS.....	48
APPENDIX D: CROSSFIRE THEORY OF OPERATION	49
BURN PHASE	49
COOL DOWN PHASE.....	49
APPENDIX D: THEORY OF OPERATION (cont'd).....	50
FAULT PHASE	50
RESET CONDITION.....	50
SYSTEM MAINTENANCE.....	50
APPENDIX E: COMBUSTION BASICS	52
APPENDIX F: REPLACEMENT PARTS	56
REPLACEMENT PARTS	56
REPLACEMENT PARTS	57
APPENDIX G: LABELS.....	58
REPLACEMENT LABELS.....	58
REPLACEMENT LABELS.....	59

FORWARD

COUNTRY FLAME

Country Flame has worked for over two decades in researching and developing biomass fuel burning stove products. In 2002, Country Flame received a national award from the Hearth Industry for its HARVESTER freestanding biomass fuel stove. Country Flame has now added the CROSSFIRE FIREPLACE INSERT biomass fuel stove to its line of products. The CROSSFIRE gives every homeowner the opportunity to convert their inefficient fireplace into a highly efficient heating machine. In addition, the CROSSFIRE ensures that the homeowner can choose from an ever growing array of fuel products to meet their home heating needs. Country Flame is dedicated to researching and developing advanced pellet stove products capable of burning a wide variety of biomass fuel. The Crossfire Model CF-04 was designed to burn APFI approved wood pellets or shelled corn. Switch grass pellets and other fuel may be burned in the Crossfire but results have not been verified.

THE PURCHASE OF A COUNTRY FLAME CROSSFIRE BIOMASS FUEL STOVE IS A VOTE TO REDUCE AMERICA'S DEPENDENCE ON FOREIGN OIL. Country Flame is very proud of this American born, American tested, and American made product. With pride and dedication, Country Flame employees wish you and your family a lifetime of happiness and warmth through the use of our products.

LET US PUT A FLAME IN YOUR HEART_h!

CROSSFIRE LIMITED WARRANTY

1. **To Whom Extended:** Country Flame Technologies; hereafter known as Country Flame, warrants, with proof of purchase and proper filing of the warranty card, the Crossfire Model CF04-CORN to the original retail purchaser only.
2. **Products/Components Warranted.** Country Flame makes the following warranties regarding its Model CF04_CORN / Pellet Stove Heaters and Inserts:
 - (a) **Heating Units.** Except as set forth below, Country Flame warrants the Crossfire Model CF-04 to be free from defects in materials and workmanship for a period of (5) years from date of purchase, so long as the unit is owned by the original consumer purchaser, subject to terms, conditions, and restrictions set forth below.
 - (b) **Blowers, Fan Speed Controls and Electrical Components.** Country Flame warrants the blowers, fan speed controls and electrical components of its Model CF-04 to be free from defects in materials and workmanship for a period of one (1) year from the date of retail purchase **OR** not more than (2) years from date of manufacture, whichever occurs first, subject to the terms, conditions and restrictions set forth below.
3. **Terms, Conditions and Restrictions.**
 - (a) **Products Not Covered.** The above warranties do not apply to glass, refractory materials such as refractory cement or firebrick, gaskets, and irons, paint, and standard accessories, and all parts not permanently attached to the heating unit. Parts not permanently attached to the heating unit are those items designed to be removed from the unit, including those removable with common hand tools.
 - (b) **Exclusions.** The above warranties do not apply to the following conditions or circumstances:
 - (1) To conditions resulting from the Crossfire Model CF-04 being installed other than in accordance with the instructions and specifications included in the operating and maintenance instructions.
 - (2) To conditions resulting from failure to provide reasonable and necessary maintenance for the Crossfire Model CF-04 in accordance with the operating and maintenance instructions.
 - (3) To conditions resulting from the alteration or modification of any Crossfire Model CF-04 by anyone other than an authorized Country Flame representative with written instructions to complete such alteration or modification.
 - (4) To conditions resulting from failure to use and operate the Crossfire Model CF-04 in accordance with Country Flame operating and maintenance instructions or as a result of misuse of the product.
 - (5) To conditions not resulting from defects in material or workmanship of the Crossfire Model CF-04.
 - (6) To conditions resulting from the improper firing or burning of materials in a Crossfire Model CF-04.
 - (c) **Warranty Registration Card.** The Crossfire Model CF-04 warranty is void and does not apply unless the Warranty Registration Card provided with the owner's manual is properly completed and mailed by the original retail customer and received by Country Flame within thirty (30) days subsequent to the date of original retail purchase.
4. **Remedies in the Event of Failure.** In the event a Crossfire Model CF-04 fails to perform as warranted, the following terms and conditions will apply:
 - (a) **Heating Unit.** Country Flame will repair, or at its option, replace any warranted part of the heating unit that fails to perform as warranted for the lifetime of the original retail purchaser, subject to the term, conditions and restrictions set forth herein.
 - (b) **Blowers, Fan Speed Controls and Electrical Components.** If the blowers, fan speed controls or components of the Crossfire Model CF-04 fail to perform as warranted for one (1) year subsequent to the date of retail purchase, Country Flame will repair, or at its option, replace the defective product or component.

CROSSFIRE LIMITED WARRANTY (continued)

- (c) **Warranty Service and Freight Costs.** Service on a Crossfire Model CF-04 will be provided by any Country Flame authorized dealer or distributor. If there is no authorized dealer or distributor in the original retail purchaser's area, the original retail purchaser may notify Country Flame at 900 George Street, Marshfield, Missouri, 65706 of any defect by providing the following information:

1. The Serial Number of the Crossfire Model CF-04
2. The date of original purchase
3. The name of the dealer where the product was purchased
4. The date of installation; and
5. A description of the nature of the defect or problem.

If service is required, the original retail purchaser must send the product or component, freight or postage prepaid, to Country Flame or a designee of Country Flame's choice. Country Flame will not pay freight or postage costs relating to products or components returned for warranty service.

- (d) **Repairs.** All repairs made by Country Flame or its authorized dealers or distributors will be to the original manufacturing specifications.
- (e) **Cost of Repair or Replacement.** Country Flame will repair, or at its option, replace the defective products or component pursuant to the conditions set forth above. The original retail purchaser is responsible for payment of any costs and expenses of disassembly, removal and reinstallation of any defective product or component and any other services involved. Such costs or expenses are NOT covered by this warranty and Country Flame is not liable for any of them.

5. **Limits on Damages.** In no event shall Country Flame be liable for damage to property, lost profit, injury to goodwill, or any other special, incidental or consequential damages resulting from any defective Crossfire Model CF-04 product or any breach of the above express warranties. Some states do not allow the exclusion or limitation of incidental or consequential damages so the above limitation may not apply to you.
6. **Limitation of Implied Warranties.** Country Flame expressly limits all implied warranties. Implied warranties include but are not limited to warranties of merchantability or fitness for a particular purpose to one year from the date of original retail purchase. Some states do not allow limitations of how long an implied warranty lasts, so the above limitation may not apply to you.
7. **Legal Rights.** This warranty gives you specific legal rights, and you may also have other rights that vary from state to state.
8. **No Other Warranty – These Remedies Are Exclusive.** Unless otherwise explicitly agreed to in writing, it is understood that this is the only warranty given by Country Flame, and Country Flame neither assumes or authorizes anyone to assume for it any other obligations or liability in connection with this Country Flame product.
9. **Additional Information.** If you wish to obtain additional information or resolve questions concerning the interpretation of any warranties of Country Flame, please write:

Country Flame
900 George Street
Marshfield, MO 65706
email@countryflame.com
417-859-0990 phone
417-859-0192 facsimile

**Place
Stamp
Here**

Country Flame Technologies
A Division of American Products, LLC
900 George Street
Marshfield, MISSOURI 65706

Fold Here

Name _____ Address _____
City _____ State _____ Zip _____
Dealer _____
Dealer's Name _____
City _____ State _____ Zip _____
Date of Purchase _____
Model No. _____ Serial No. _____

The express warranties made by Country Flame Technologies do not apply unless this warranty card is received by Country Flame Technologies from the original retail purchaser no later than thirty (30) days subsequent to the date the Country Flame product was originally purchased.

Signature _____ Date _____

THE CROSSFIRE OPERATION

FEATURES

Country Flame designed and built the CF04 -CORN stove to burn 100% shelled corn. Unlike conventional pellet stoves, the Crossfire was designed to handle large amounts of ash. This means the Crossfire is capable of burning corn or a mix of wood pellets and corn while reducing the possibility of choking the fire from ash residue. Country Flame is pleased that customers are finding wide success in burning locally available fuels but Country Flame cannot support or warranty the burning of untested fuel in the Crossfire.

Before beginning to install or operate the Model CF-04 Crossfire, please consult with the local building authority to obtain a permit and ensure a professional installs or certifies the installation of this product. Before a homeowner operates this stove, a thorough operational understanding should be obtained from reading and understanding this manual. Failure to adhere to all safety notes and instructions contained herein can impact homeowner insurance, void warranty, and create hazardous situations leading to a smoke damage, fire, or even death.

The Model CF-04 was designed as a insert only model stove. The Crossfire was designed to be installed into an existing zero clearance fireplace or an existing masonry fireplace. There are no leg or pedestal base options for the Crossfire. Contact Country Flame or one of its local authorized dealers to discuss and select possible options that are available for the Crossfire. Once installed, the Crossfire is remarkably simple and safe to operate. FIGURE 1 and FIGURE 2 defines Crossfire components. From a relatively small firebox the Crossfire generates a very beautiful flame with lots of heat being produced into the room where the unit is installed. Clean AFPI approved fuel is to be loaded into the hopper. A motor turns an auger that delivers fuel to the combustion chamber on a timed basis. Corn or pellet fuels can be fed into the Crossfire burn pot.

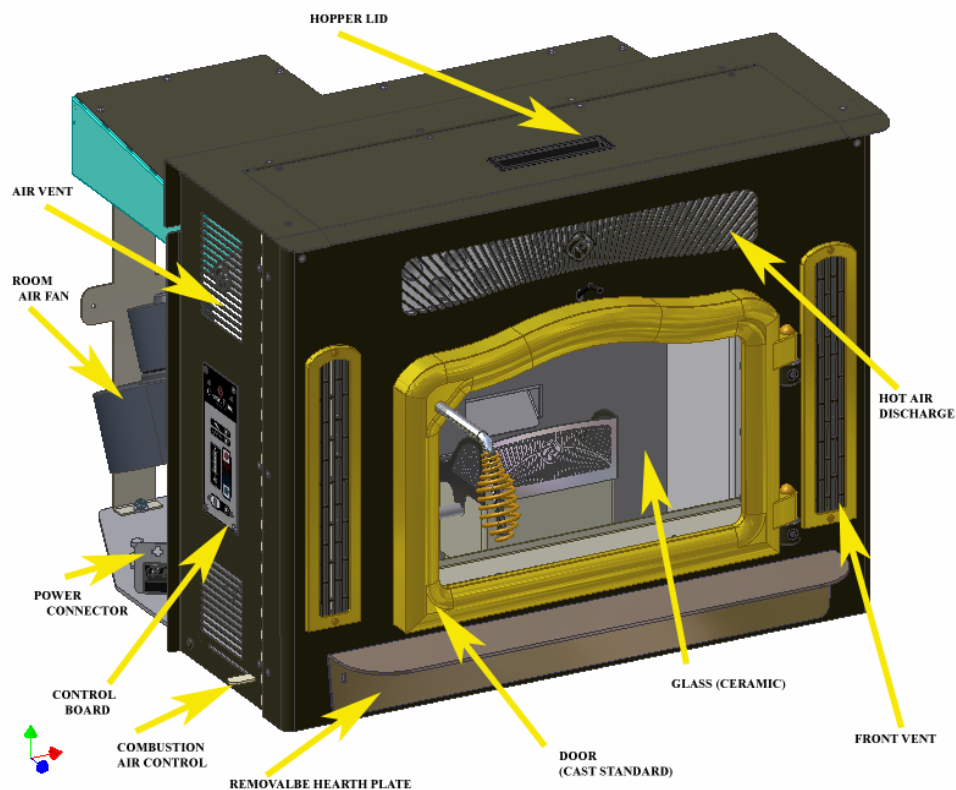

FIGURE 1: CROSSFIRE MODEL CF04-CORN

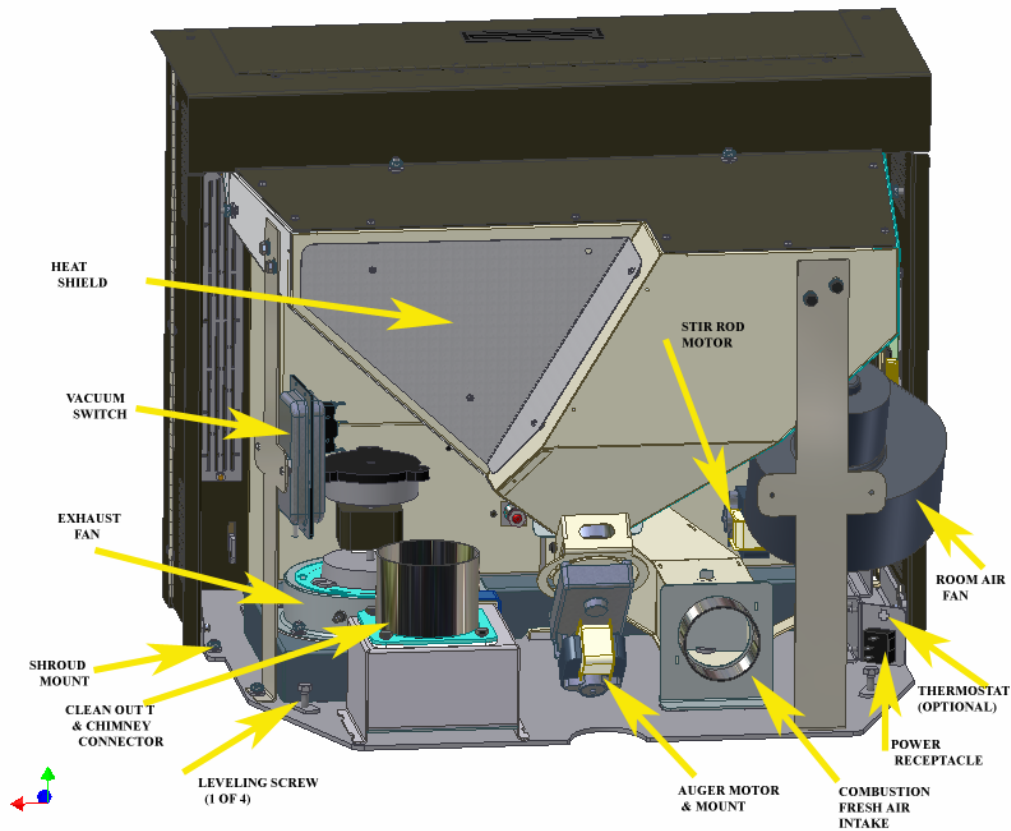

FIGURE 2: CROSSFIRE COMPONENTS

SAFETY FEATURES

The Crossfire comes standard with a number of advanced safety features; however, to ensure maximum safety install the stove according to all national and local codes and follow all operating and maintenance procedures. The Crossfire requires a fresh air supply to ensure proper combustion. This fresh air is used in the combustion process to achieve thorough burn of all fuel. The Crossfire needs a sealed and properly designed exhaust flue system. This exhaust flue will be used to remove combustion gasses outside the home. **REMEMBER:** one of the leading causes of house fires is due to improper installation or improper operation of a stove product. Proper installation and operation of the Crossfire is required to obtain Homeowner insurance coverage. And, the Crossfire needs a reliable source of electrical power. Without reliable utility power or a means to ensure reliability, the Crossfire operation will be problematic.

It will require some effort and learning for the homeowner to thoroughly understand the operating characteristics of the Crossfire. More importantly, the operator needs to know how to control each one of the stove’s operations. The Crossfire has an electronic control system whose “brain” is constantly monitoring stove operations in order to ensure fuel combustion efficiency and to ensure maximum heat output of this product. The Crossfire’s electronic control provides a simple one stop location for the homeowner to control Crossfire performance. To ensure safe operation, the Crossfire’s electronic control is constantly monitoring pressure and heat activated switches, and input power to ensure proper operation. Additional features include an enclosed firebox, high temperature ceramic glass, optional thermostatic control, a high temperature wiring harness, making the Crossfire an extremely safe stove.

BATTERY BACKUP SYSTEMS

The Country Flame Crossfire Model CF04-CORN, relies on electrical energy (wall power outlet) to properly operate. Without electrical energy or with interruptions to the source of electrical energy, the Crossfire stove’s operation will be erratic at best. Is power quality, power reliability, or routine winter storm conditions a cause of power problems in a specific locale? If it is, the homeowner will need to provide backup power to

ensure stable operation of the Crossfire. Fortunately, there are simple, reliable, and cost effective power backup solutions available. Today, a homeowner can choose from a variety of power conditioning systems from a number of “big box” retail stores. For example, Home Depot, Circuit City, Best Buy, Wal-Mart, or other stores carry standard power conditioning equipment. Two good quality power conditioning equipment manufacturers are APC and TrippLite. These uninterruptible power supplies (UPS) include the capability to handle power failures, brown outs, power surges, line noise, and sell for around \$35 to \$150. UPS system cost is largely defined by the features included and the amount of time (battery size) the UPS can operate before recharging of the battery is required. UPS systems are sold by the number of electrical outlets, the volt-amperes (watts), and the additional features included.

FUEL REQUIREMENTS

The Crossfire Model CF04-CORN was designed to burn #2 shelled corn, or any mix of both corn and Premium Hardwood Pellets. The corn’s moisture content should be limited to no more than 14% moisture content. **Country Flame recommends** corn fuel moisture content be maintained somewhere in the **range of 10% to 12%. USING SEED CORN AS FUEL IS DANGEROUS TO OCCUPANTS. BURNING SEED CORN VOIDS THE COUNTRY FLAME WARRANTY.**

If pellet fuel is added to the corn in the Crossfire, Country Flame recommends no more than 8% moisture content. The American Pellet Fuel Institute establishes standards for pellet fuel manufacturer’s product. Pellet Manufacturers voluntarily follow these standards but homeowners should know what to look for. The following terms should be understood by the homeowner:

ASH: Biomass stoves produce two kinds of ash:

- 1) Solid ash residue in the firepot; and
- 2) Fly ash (un-burnt particles) and air born fly ash (sparklers) are created during the combustion process. The Crossfire has an ash compartment which aids in cleaning the stove. Ash can also accumulate in "ash traps" which need to be cleaned periodically. The remaining fly ash is blown into the flue system which will also require periodic cleaning.

FINES: (sawdust): Fines are caused by pellet disintegration that occurs during transport or storage of pellets. Two potential problems – fines can create dust in the home and fines cause interference to the flow of pellets in the fuel hopper.

BTU's: (heat) PER POUND: The variation of BTU's per pound in pellet or corn fuel is usually not noticeable to most users. Overall stove efficiency (combustion efficiency times heat transfer efficiency) has a greater impact on the heat delivered to the home.

DENSITY: Pellet density (measured in pounds per square foot) determines the maximum amount of energy that can be delivered to the combustion chamber. Low density fuels may cause the fire to go out on low heat settings without proper adjustments to the air-to-fuel ratio.

SALT: Salt in pellets can cause stove deterioration (rust). The Pellet Fuels Institute is participating in tests to determine the effects of salt and the most accurate methods of measurement. The APFI will publish standards that will result in recommended standards for sodium in pellets.

CLINKERS: Clinkers are the result of impurities in pellets or corn. Clinkers may also occur due to ash fusion (ash melted together in the burn pot), and can be minimized by properly adjusting the air-to-fuel ratio.

DIRTY GLASS: Glass becomes dirty during normal or faulty combustion. Some fuels produce a film on the glass to which ash adheres, making a clean glass more difficult.

Pellet fuel manufacturers should be able to show test results for BTU's, ash content, and the amount of fines in their product. Do not hesitate to contact the pellet manufacturer if you have questions or concerns. If questions remain about the Crossfire, please contact a local authorized Country Flame Dealer for assistance.

CROSSFIRE STARTUP

The first step in preparing the Crossfire for use is to remove it from its shipping crate. Ensure that all materials packed in the burn chamber have been removed. Ensure proper cleaning of the Gold (optional plated l) door/trim and clean all glass per instructions included in this manual.

NOTE:

- (1) Failure to properly pre-clean the Gold (or any plated) door or trim and the glass before lighting the first fire could permanently damage these items.
- (2) **DO NOT burn seed corn as it is dangerous and voids the Country Flame warranty.**

SYSTEM START UP GUIDE

CROSSFIRE – CORN STOVE

1. Ensure that the CF04-CORN stove has been installed correctly, and that the manual has been read and thoroughly understood.
2. Fill hopper with #2 shelled corn (**NOT SEED CORN**) or any mix of Corn and Premium Hardwood Pellets, close hopper lid.
3. If the auger has been previously primed or the stove was operational and shut down without running out of fuel, proceed to step no# 5.
4. “Prime” the auger system of the new Corn stove, or a stove that previously has run out of fuel. This is done simply by pressing and **holding down** the control board “**ON/OFF**” button (located at the bottom of the control board) until the “**Green**” auger feed light starts to flash, (approx 15 seconds) then release button. Prime mode will take approx. 10 minutes, when you see corn begin to drop into the burn-pot press and **hold** the control board “**ON/OFF**” button for approx. 5 seconds. (The green light next to the “**ON/OFF**” button should turn to red, then release.) NOTE: While in the prime mode the heat setting indicator lights will continue to flash from low to high.
5. **LIGHTING PROCEDURE** Country Flame recommends starting the Crossfire Corn stove with Wood Pellets. Open stove door, remove un-burnt ash prior to placing Pellets in layers with igniter/burn gel or igniter bricks into the Burn-Pot, just covering the stir-rod. Simply press and hold the “**ON/OFF**” button on the control board for approx. 5 seconds. (The light next to the button will turn from red to green, then release.) The light next to the igniter symbol will come on (red). Manually light the pellets, once the fuel has been ignited, close the Crossfire door securely. Close the inlet air damper lever almost completely (towards the front of the stove is closed) until fire gets going. Then gradually increase the amount of inlet

air to the stove to intensify the flame. **You must establish a strong, intense burn** before corn can be fed into stove. (this process takes approx.15-20 minutes)

6. **SYSTEM START** Upon establishing an intense hot fire in the Burn-Pot, press and hold the “**ON/OFF**” button on the control board for approx. 5 seconds. The (red) light next to the igniter symbol will change from slow to fast flash, then release button. **If the stove is at the proper temperature, the operational sequence will begin automatically.** (If it does not, see guide on back of this sheet) The stove will start up in heat setting #3. Allow adequate burn time for stove to heat up and stabilize prior to temperature setting change. (approx. 30 min.) **Adjust the inlet air control as required to sustain even continuous burn.**

FIGURE 3

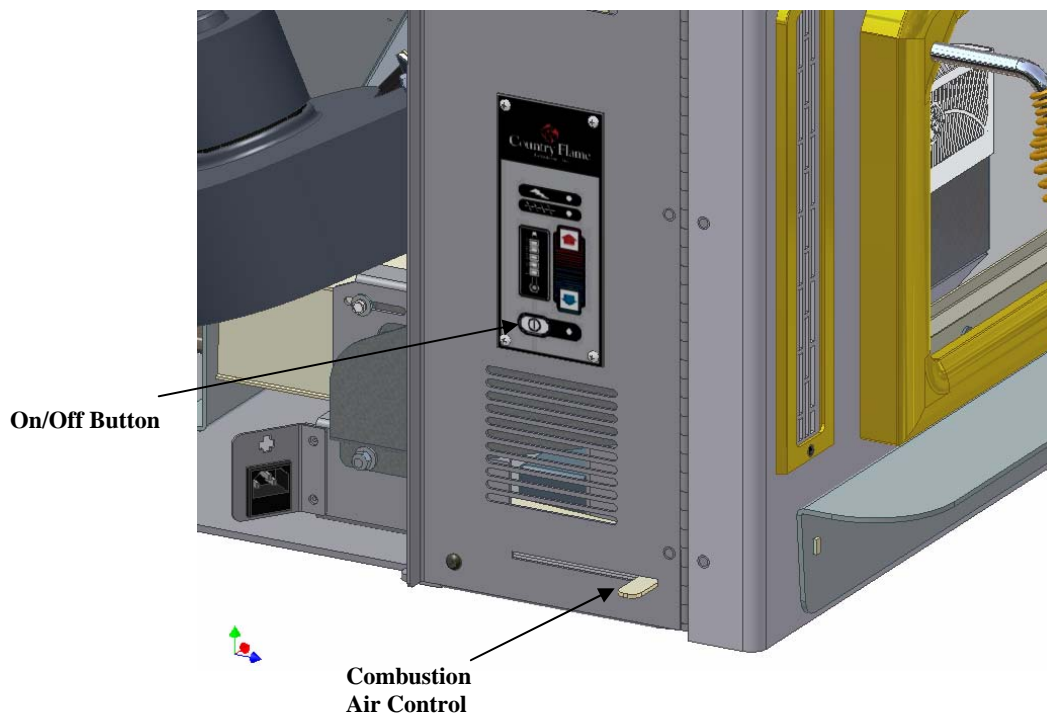

OPERATING REFERENCE GUIDE CROSSFIRE – CORN STOVE (SEE FIGURE #3)

- **DO NOT** use any other **ignition accelerant** other than igniter/burn gel or igniter blocks to start or enhance the fire in the Crossfire stove.

- **FUEL** the only fuel the CF04-CORN stove is designed to burn is #2 shelled Corn (10-12% moisture) or any mix of Corn and Premium Hardwood Pellets. It is highly recommended that the corn be “CLEANED” (free of dust, fines, & any other foreign matter) for optimum stove performance. **Burning SEED CORN as fuel is extremely dangerous to occupants and voids the Country Flames warranty.**
- To enhance the initial start-up fire, manually rotate the stir rod occasionally. This is done by pressing, and **holding** down both the “UP and “DOWN” arrow keys on the control board at the same time. This will mix the burning pellets, speeding up the burn process. Note: It rotates at only 1 RPM.
- **NOTE:** If the system does not come on after doing Step #6 per the **start-up guide** it is because the stove temperature is not hot enough. Carefully open the door and manually add more pellets to the fire, repeat step #6. Once the system comes on and is automatically set to heat setting #3, allow the stove adequate time to burn and heat up properly (approx 30 min.) before changing settings. If a heat setting change is made more than one bar at a time, (red and blue arrow keys) there is a 2 minute response delay in the fan speed for each level increase. **Adjust the inlet air control as required to sustain even continuous burn.**
- **INLET AIR** Make small, slow incremental changes in the air control. **If to much air is given, it will cool the corn below its ignition point and the fire will go out.** The higher the heat level setting on the stove the more inlet air required for a complete burn of the Corn. Setting No# 5 will require a little more air than setting No#1. Adjust the inlet control lever accordingly. (To the front of the stove is CLOSED, see manual for illustration)
- A visual reference to the Ideal burn condition of Corn would show a fuel level in the Burn-Pot “**BELOW**” the stir rod at **ALL TIMES**. This will prevent any possibility of an over feed condition. The fuel feed rate can be regulated by the potentiometer on the back of the control board. (See manual)
- **STOVE SHUT-DOWN PROCEDURE**, during normal operation, simply push the “ON/OFF” control button, (bottom of the control pad) and hold it for approx. 5 seconds or until the lights on the heat level settings start to flash from top to bottom, then release. The stove is now in its cool down cycle. (See Manual)
- All questions or concerns about lighting or other stove operational issues should be directed to your local **Country Flame Dealer**.

The stir rod will be controlled by the “*Intelli-Choice*” control board. This stir rod assists in mixing fuel with air in the burn pot. The stirring action improves the mixing of oxygen and fuel and accelerates the combustion process. As heat settings are changed on the *Intelli-Choice* control board, the stir rod speed will automatically be adjusted to more closely match the feed rates of the different heat settings.

The stir rod assists in minimizing “clinker” build-up in the burn pot. If the proper air-fuel mixture is set by the homeowner, the Crossfire will generate a very fine ash rather than clinkers. In addition, the stir rod ensures that the fuel and flame are constantly agitated within the burn pot to enhance the combustion process. The Crossfire burn pot has been designed to ensure maximum efficiency of burn while minimizing the amount of ash being produced at the same time minimizing the clinkers that might choke out a fire. Testing by Country Flame has shown that the Crossfire can be continuously operated for several days without requiring cleaning. However for optimum stove performance, make sure all air passages and burnpot are free of obstruction. It should be recognized by the homeowner that environmental variables as well as the type of fuel being burnt can have dramatic effect on the amount of ash or clinkers formed during the burn cycle. Burn pot cleaning will depend upon the quality, quantity, and moisture content of the fuel. Ash removal will be required from time to time depending on the amount of usage and the heat output required. The Crossfire stove should be shut down and cooled before cleaning or removing any ash from the firebox.

CLEANING - ASH REMOVAL

The Crossfire stove has a deep ash container built into the firebox. There is no removable ash pan located within the Crossfire. This means the operator must allow the ash to properly cool and then vacuum the ash from the stove and BURNPOT with an industry approved ash vacuum. Once the ash has been removed from the firebox, it should be stored or disposed of in proper containers. Failure to properly handle ash, even when the ash is believed to be completely cool, can lead to a fire.

Always remove ashes after they have been allowed to cool properly. Hot ash is dangerous to both surrounding areas and occupants and can cause fires or severe burns. Wait until the fire has been out for several hours before vacuuming the firebox with an industry approved ash vacuum. Protective gloves should be worn anytime ash is removed. Dump all ash into a proper ash container and remove to a safe outdoors area. Remember that although the ash may look and feel cool to the touch, a smoldering ember can start a fire. **CAUTION:** Care should be used to store any ash in a proper container with an approved airtight lid. If ash is taken outside, water should be poured over the ash to ensure no fire flare up can occur.

Intelli-Choice CONTROL BOARD

In 2001 Country Flame introduced its own control board technology, called the “*Intelli-Choice.*” Country Flame’s control board technology was introduced across all pellets and corn stove product lines. The *Intelli-Choice* control board is being used exclusively on Country Flame product. This control board technology was developed to ensure better support to customers. Country Flame will seek to provide the most advanced controls while maintaining the look and feel our dealers and customers have come to know and expect. Country Flame also wants to ensure its product can be upgraded to newer and more advanced technology if and when this technology becomes available and the customer chooses to obtain it. Country Flame is committed to its customer base. Country Flame will strive to make the service support process easier through systematic troubleshooting procedures and repair events that should allow for evolving “plug n play” operations. Country Flame’s goal is to ensure a certified service technician can diagnose and repair any stove problem in less than 30 minutes. FIGURE 4A depicts control board basic theory and FIGURE 4B provides a brief description of sensor controls.

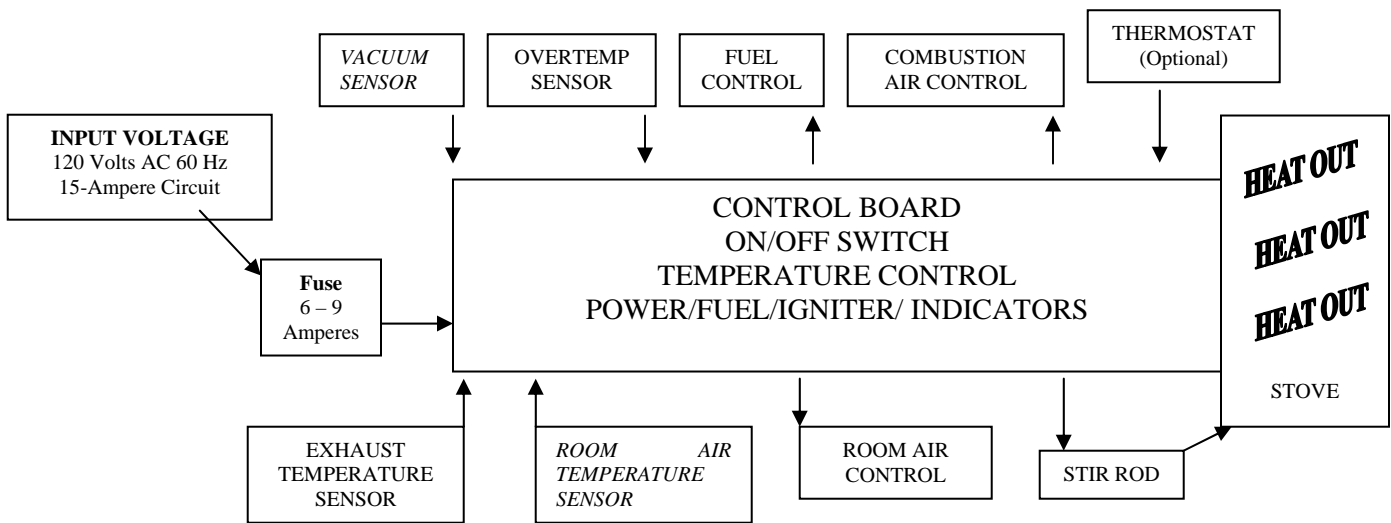

FIGURE 4A: CONTROL BOARD BLOCK DIAGRAM

Input Voltage	Alternating Current (AC) Input provided by the local power company. This source of energy must provide a 120 Volt input signal with a frequency of 60 Hertz and a maximum branch current capacity of 15 Amperes. If other devices are connected to the branch, interference or over current may cause circuit breaker to trip.
Fuse	The AC fuse should be rated between 6 and 9 amperes. The recommended fuse is a Little Fuse Model _____.
Vacuum Sensor	Ensures that no blockage of the combustion input or combustion exhaust air occurs. If the vacuum sensor does not operate properly, the Control Board will not allow the stove to operate.
Exhaust Temperature Sensor	Presently, this sensor is a snap disk operating at 110° F +/- 20° F. This sensor ensures proper exhaust temperature has been reached and that a fire is present in the burn pot before the control system begins the burn cycle.
Room Air Temperature Sensor	Presently, this sensor is a snap disk operating at 110° F +/- 20° F. This sensor ensures that a proper amount of heat is available at the heat exchanger before the room fan is allowed to operate. If the sensor allows the fan to come on to early, the combustion chambers temperature could drop to the point that self-combustion (ignition temperatures) cannot be maintained.
Overtemp Sensor	Presently, this sensor is a snap disk operating at 250° F +/- 20° F. The purpose of this sensor is to shut the entire system down in the event the firebox causes an overheat condition.
Fuel Control	The fuel control is a signal provided from the Control Board to the Auger Feed Motor. The Control Board controls the amount of time that the Auger Feed Motor is on and thereby controls the amount of fuel fed to the fire pot.
Room Air Control	The room air control is a signal provided from the Control Board to the Room Air Fan. The Control Board controls the phase angle and thereby the amount and time an AC voltage is applied to the Room Air Fan. This signal controls the speed of the room air passing over the heat exchanger tubes and the amount of heat delivered to the living space.
Combustion Air Control	The combustion air control is a signal provided from the Control Board to the Combustion Air Fan. The Control Board controls the phase angle and thereby the amount and time an AC voltage is applied to the Combustion Air Fan. This signal controls the speed of the combustion air passing through the burn pot for the different heat settings
Stir Rod	An AC device used to create turbulence in the burn pot. The stir rod reduces the potential of a klinker thereby ensuring more efficient combustion process. The operator must remove and clean the stir rod from time to time. Be careful not to damage or break the stir rod.
Thermostat (optional)	A thermostat input is provided on the back of each Country Flame product. The Control Board has individual personality modules that allow for stand-alone, semi automatic, or fully automatic thermostat operation.

FIGURE 4B: STOVE COMPONENT DEFINITIONS

FIGURE 5 displays the Country Flame Control Board front panel. Each function of the Control Board is identified. Controls having more than a single function are identified with asterisks. All control board functions are explained in FIGURE 6.

"Intelli-Choice"

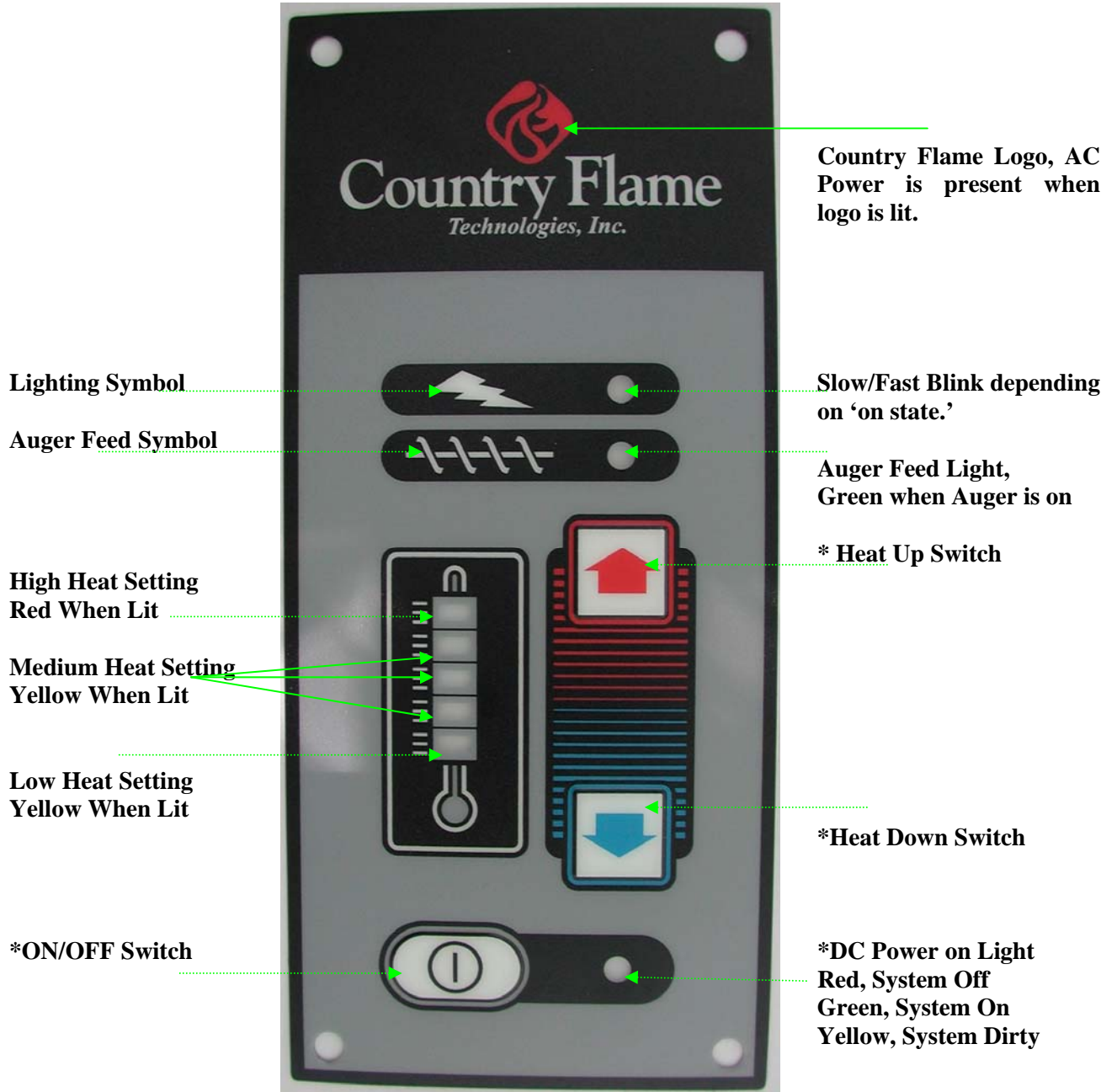

FIGURE 5: CONTROL BOARD FACE PLATE

ON/OFF SWITCH	The <i>Intelli-Choice</i> ON/OFF Switch either turns the system on or off by holding the switch for approximately 5 seconds. The ON/OFF Switch can also be used to initiate the FUEL PRIME MODE by holding it for approximately 30 seconds. When in the prime mode the Thermostat lights will sequentially light from top to bottom simulating a “filling action” of the auger tube.
HEAT UP/ HEAT DOWN SWITCH	When these two switches are pressed during the STARTUP CYCLE only, they can be used to turn the stir rod. In operational mode these switches only function is to change heat up and down settings.
DC POWER LIGHT	This is a 3-color light when AC power is applied. A red light indicates that the Control Board has DC Power available but the system is off. A green light indicates that the System is on. A yellow light indicates that the combustion air should be cleaned. As Country Flame works to improve the sensor technology, this yellow light will become more valuable to the service technician as well as the homeowner.
HIGHWAY PATROL MODE	When all Control Panel lights are flashing on and off, this indicates that the Product has an encountered an unknown state. Nothing more, nothing less. The purpose of these flashing lights is to alert the home owner or the service technician that the stove operation ended out of sequence, ran out of fuel, or encountered a power interruption that the Control System could not recover from.
COOL DOWN MODE	In the Cool Down Mode, the Heat Setting lights will sequentially go out from top to bottom, all relight and then sequentially go out from top to bottom. This cycle will continue until such time that the Control Board senses the stove has properly cooled down.
HEAT SETTING 1 THROUGH 5	Each heat setting, controlled by the stove Heat Up or Heat Down switch, is provides as much combustion air and fuel as is required for that heat setting. Due to the number of unique environmental variables as well as variations in pellet fuel used in different regions, Country Flame cannot provide exact BTU ratings for each heat setting except those that were established in Government Test Labs under controlled conditions. At the same time, the rule of thumb is that each heat setting on the Country Flame line of Biomass Product starts at one pound of fuel per hour and increments to a top setting of five pounds of fuel per hour. Using a BTU rating of from 4,000 to 10,000 BTU per pound of fuel, depending on the type and moisture content of the fuel, an estimate of heat output can be made.

FIGURE 6: CONTROL BOARD FUNCTIONS

Country Flame’s control board provides reliable control of stove functions with minimal human intervention required. This control technology provides flexibility in adapting to future changes and improvements in technology. Finally, this control technology offers a simple interface between the operator and the product being used.

Country Flame’s control board is sensitive to utility grid power variations. In the event a homeowner’s area has difficulty with utility power fluctuations, Country Flame’s stove products can be interfaced to an inexpensive battery back up system. The actual cost of a battery backup system will be fully dependent on customer requirements. From random power “glitches” or short duration electrical power interruptions to major power outages, the Country Flame stove can operate off battery or generator backup systems. Contact Country Flame or one of its local authorized dealers to discuss the specifics of a single application.

In conclusion, Country Flame is striving to become a leader in the area of biomass control and product technology. This leadership will provide direct benefits to Country Flame dealers and our customers. As always, Country Flame welcomes input on how to better meet the customer’s needs.

In order to utilize the full capabilities of the Control Board, the homeowner should be familiar with the backside of the Control Board. FIGURE 7 provides additional information about the major components on the component side of the control board.

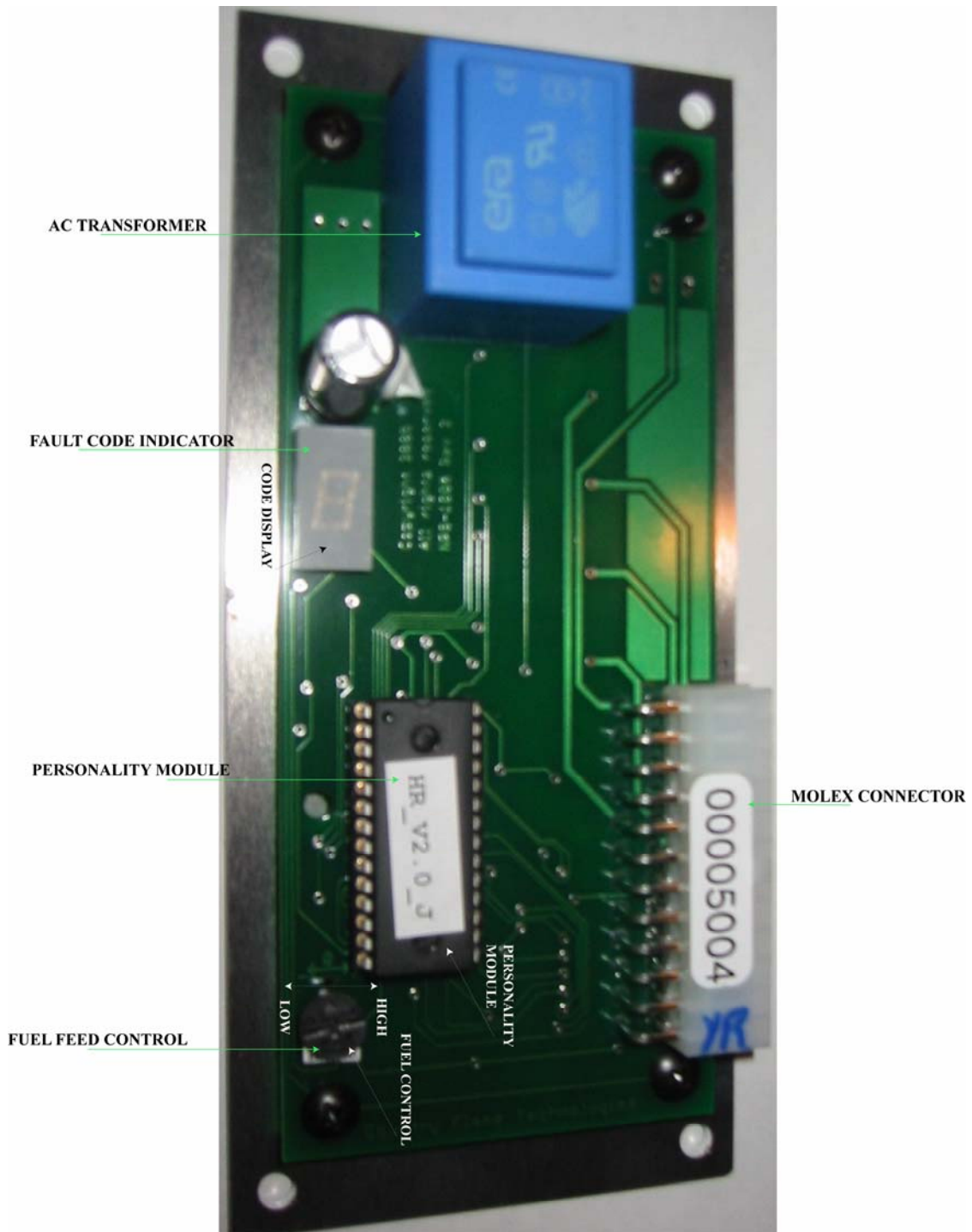

FIGURE 7: CONTROL BOARD COMPONENT SIDE

TROUBLESHOOTING CODES FOR COUNTRY FLAME CONTROL BOARD

The following table provides additional information as to the reason different fault codes may be observed. The table of information assumes that proper AC voltage, AC line frequency, and a properly working control board are available to and installed in the stove product.

<i>Intelli-Choice</i> Code Display	Possible Causes For Code Displayed
Code 0	System should exhibit Code 0 when the power is first supplied to stove product. After a few seconds, the vacuum switch should pull closed and cause a Code 1 to be displayed. If Code 0 remains, this means the (a) control board is defective, (b) the vacuum switch is defective, (c) the vacuum line is plugged between the vacuum switch and the combustion exhaust fan, or (d) the wiring between the control board and the vacuum switch is defective. The Control Board provides 5 volts DC to the vacuum switch and checks for its presence. The vacuum switch is normally closed. When the combustion exhaust fan creates enough vacuums, the vacuum switch opens, removing the 5VDC signal and telling the control board a vacuum is present. This is the START-UP CYCLE.
Code 1	<i>Intelli-Choice</i> Control Board recognizes the vacuum switch is operating properly. Stove will go from START-UP CYCLE TO IGNITION CYCLE.
Code 2	<i>Intelli-Choice</i> Control Board recognizes a vacuum is not present AND the overtemp snap disk is hot. A wiring problem has occurred, OR two components (vacuum switch and overtemp disk) are bad, which is highly unlikely.
Code 3	<i>Intelli-Choice</i> Control Board recognizes overtemp disk is hot. A wiring problem has occurred, OR the control board is bad, OR the overtemp disk is bad.
Code 4	<i>Intelli-Choice</i> Control Board recognizes a vacuum is not present AND there is a problem with the exhaust snap disk, OR the room air snap disk OR there is a wiring problem. IF the stove has ever been operating properly, the likelihood of two items failing at the same time is highly unlikely.
Code 5	<i>Intelli-Choice</i> Control Board recognizes a problem with the exhaust snap disk, OR the room air snap disk OR there is a wiring problem. It is most likely a problem with the exhaust snap disk if the stove has been operating properly previous to Code 5 being displayed.
Code 6	<i>Intelli-Choice</i> Control Board recognizes a vacuum is not present AND there is a problem with the exhaust snap disk, OR the room air snap disk AND the overtemp snap disk OR there is a wiring problem. If the stove is cool then both the room air snap disk and overtemp snap disk are bad, which is highly unlikely; therefore it is most likely the exhaust snap disk and the vacuum has become plugged with soot as the stove cooled down.
Code 7	<i>Intelli-Choice</i> Control Board recognizes a problem with the exhaust snap disk, OR the room air snap disk AND the overtemp disk, OR there is a wiring problem. It is most likely a problem with the exhaust snap disk if the stove has been operating properly.
Code 8	<i>Intelli-Choice</i> Control Board recognizes a vacuum is not present AND there is a problem with the room air snap disk, OR there is a wiring problem. It is most likely the room air snap disk with a clogged vacuum if the stove has been operating properly.
<i>Intelli-Choice</i> Code Display	Possible Causes For Code Displayed

Code 9	<i>Intelli-Choice</i> Control Board has completed the IGNITION CYCLE and is switching to the BURN CYCLE. The igniter should shut down to conserve energy and the stove will now watch for the room air snap disk to close before recognizes a problem with the exhaust snap disk, OR the room air snap disk, OR there is a wiring problem. If the stove is cool, it is most likely the exhaust snap disk. If the stove is hot, it is most likely the room air snap disk.
Code A	<i>Intelli-Choice</i> Control Board recognizes a vacuum is not present AND there is a problem with the snap disks, or there is a wiring problem. If the stove is cool, then it is most likely the exhaust and overtemp snap disk. If the stove is hot, then it is most likely the room air snap disk OR there is a wiring problem. The vacuum has plugged due to improper airflow or inefficient burn process.
Code B	<i>Intelli-Choice</i> Control Board recognizes there is a problem with the snap disks. If the stove is cool, then it is most likely the exhaust and overtemp snap disk. If the stove is hot, then it is most likely the room air snap disk, OR there is a wiring problem.
Code C	<i>Intelli-Choice</i> Control Board recognizes a vacuum is not present AND there is no problem with the snap disks if the stove is hot and has not reached overtemp condition. If the stove is cool, then both exhaust and room air snap disk are bad OR there is a wiring problem. The vacuum has plugged due to improper airflow or an inefficient burn process.
Code D	<i>Intelli-Choice</i> Control Board recognizes system is operating properly in the BURN CYCLE. The system will stay in the BURN CYCLE until some outside force interrupts the system, i.e., fuel hopper empties, power interruption, system turned off by operator, thermostat does not call for heat, etc.
Code E	<i>Intelli-Choice</i> Control Board recognizes a vacuum is not present AND an overheat condition of the stove, if the stove is hot. If the stove is cool, then all snap disks are bad OR there is a wiring problem. If the stove has been operating properly, it is most likely an overheat condition due to failure of an exhaust or room air fan. The vacuum has become plugged due to inefficient burn.
Code F	<i>Intelli-Choice</i> Control Board recognizes an overheat condition of the stove, if the stove is hot. If the stove is cool, then all snap disks are bad OR there is a wiring problem. If the stove has been operating properly, it is most likely an overheat condition due to failure of an exhaust or room air fan.
Code L	<i>Intelli-Choice</i> Control Board recognizes a startup problem. The igniter did not create a fire within the specified time (approximately 10) and has timed out. The igniter system or combustion airflow should be checked and corrected.
Code P	<i>Intelli-Choice</i> Control Board has been put into the prime mode. The system is “loading” the auger full of fuel. Once pellets or corn start dropping into the burn pot, the system should be turned off and then startup procedures can be initiated.

NOTE: The above code definitions have been **reverse highlighted** for all normal operating codes. Any Code Definition in the table that is not **reverse highlighted** is considered an abnormal condition and should be corrected before the stove is allowed to continue to operate.

STOVE ELECTRICAL DIAGRAM

FIGURE 8 provides the CF04-CORN electrical schematic of the components and sensors that are either operated or monitored by the Country Flame control board. Please refer to this diagram when necessary.

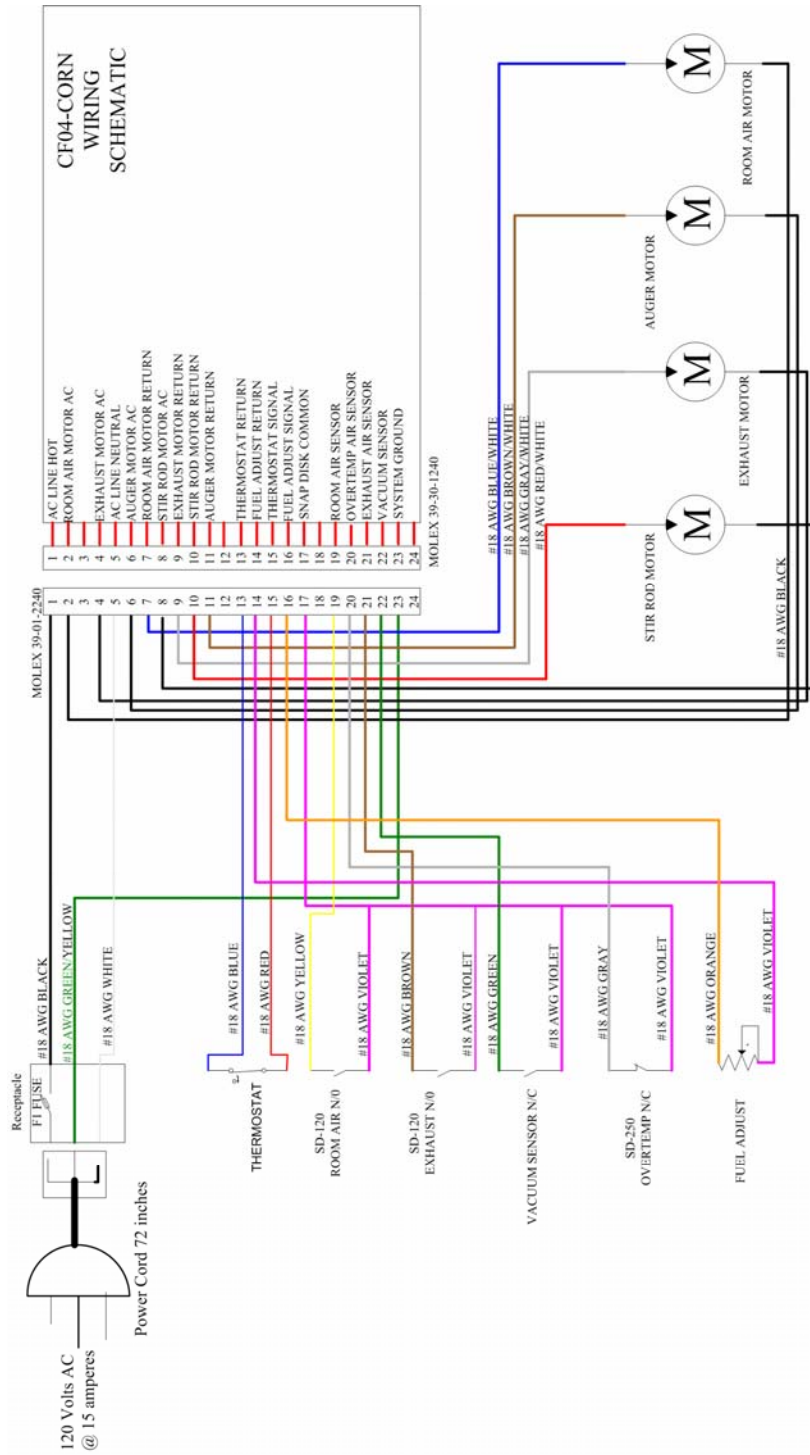

FIGURE 8: ELECTRICAL DIAGRAM

STOVE SPECIFICATIONS

TABLE 2 shows the physical dimensions of the Crossfire product.

CROSSFIRE	DIMENSIONS (IN INCHES)
STOVE HEIGHT (At Front)	22.5"
STOVE DEPTH (From Shroud)	14.0"
STOVE WIDTH (Rear)	26.0"
STOVE WIDTH (At Shroud Mount)	25.5"
STOVE WEIGHT (empty)	220 pounds
SHROUD WIDTH, (standard)	42.0"
SHROUD HEIGHT (standard)	30.0"
SHROUD WIDTH, (oversized)	48.0"
SHROUD HEIGHT (oversized)	32.5"

TABLE 2: CROSSFIRE-CORN SPECIFICATIONS

ELECTRICAL REQUIREMENTS

The Crossfire Model CF-04 requires a code compliant grounded 120 volt, 15 ampere, and 60 hertz electrical outlet. The Crossfire utilizes only a fraction of the 15 amperes rating of a code compliant outlet but it is strongly recommended that a dedicated circuit (versus a branch electrical circuit) be provided for the stove to ensure no interference from other electrical appliances.

GOLD DOOR CARE

All Crossfire plated doors and trim (gold or nickel) should be wiped down **BEFORE THE FIRST FIRE** to prevent potential permanent damage to occur to plating. For general cleaning, use a dry cloth and wipe the plated surface to ensure the luster and beauty lasts a lifetime. Always use an approved glass cleaner (i.e. Windex, Glass Plus) and a lint free soft cloth to polish the doorframe. **DO NOT** use abrasives, like steel wool, brass polish, or cleaners, like Comet. Improper cleaners can permanently scratch the finish. A damaged door can be returned to Country Flame for refinishing but repair is expensive. Proper care of the Crossfire plated door and other plated trim will ensure these parts will survive a lifetime of use. A painted Crossfire door requires no specific care.

OPTIONAL FEATURES

There is an ever growing list of options for Country Flame stove products, including the Crossfire. Contact an authorized Country Flame dealer for more information.

OPTIONAL THERMOSTAT OPERATION

A thermostat option is available for the Crossfire.

CROSSFIRE IS COLD

- See start-up procedure.

CROSSFIRE IS HOT

- If the stove is set to a heat setting greater than 1 when the thermostat calls for heat, the *Intelli-Choice* Control Board will remember this setting and return to this setting any time heat is called for by the thermostat.
- If the heat level is equal to 1 when the thermostat calls for heat the *Intelli-Choice* Control Board will use this setting whether heat is called for or not.
- The stove will operate at the selected Heat Level until such time as the thermostat stops calling for heat. The *Intelli-Choice* Control Board will then return the stove back to heat level 1. The last heat level programmed by the operator will be remembered by the software for use as the next Thermostat Heat Level when heat is again called for by the thermostat.

CHANGE HEAT LEVEL (thermostat active)

- When the homeowner changes the control board heat level setting, while the thermostat is active (calling for heat,) the new setting becomes the new thermostat (call for heat) setting. The stove will

move to that heat setting anytime the thermostat calls for heat. Otherwise, when the thermostat no longer calls for heat, the control board sets the stove to Heat #1.

- If the operator changes the heat level to 1 while the thermostat is calling for heat, it will become the new Thermostat Heat Level. But because this is the same setting as when the thermostat stops calling for heat, the operator will get no indication that the thermostat is in control of the stove.

CHANGE HEAT LEVEL (thermostat inactive)

- If the operator makes a change to the heat level while the stove is inactive, the stove will move to that level. The next time the thermostat calls for heat, the most recently programmed heat level will become the Thermostat Heat Level and the stove will operate at that point until the thermostat no longer calls for heat.

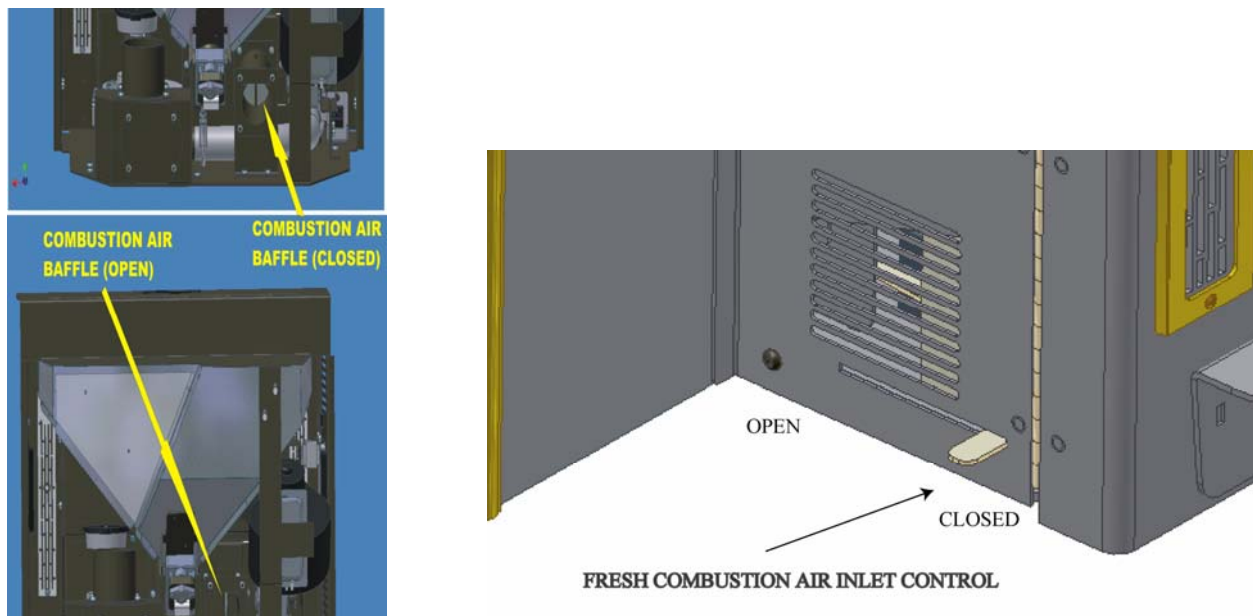

FIGURE 10: CROSSFIRE COMBUSTION FRESH AIR CONTROL

COMBUSTION FRESH AIR CONTROL

Combustion fresh air can be controlled on the Crossfire. This optional control assists in optimizing the burn rate of the fuel. All air entering the firebox is controlled with this fresh air control system. A control lever as shown in figure #10 above, open and closes the inlet air damper. This air control should allow the homeowner the ability to adjust for any variation in fuel to ensure an efficient burn. By opening or closing this baffle the amount of fresh air allowed into the combustion chamber can be controlled. If the fresh air is connected to a pipe leading outside the house, the fresh air control should be kept in the closed condition to minimize air infiltration into the home when the Crossfire stove is not in use.

INSTALLATION

INSTALLATION PREPARATION

Country Flame strongly recommends the Crossfire be installed by a certified professional. Improper installation will create long-term operational and maintenance problems that will plague the homeowner until corrected. The first step is to ensure all necessary parts are available to complete a proper installation. Country Flame recommends a homeowner purchase the Crossfire from an authorized dealer who both knows and supports Country Flame product. If purchased from Country Flame, a Crossfire shroud will need to be ordered based on the size of the fireplace opening and the trim package desired. A flue system can be ordered from Country Flame or bought from many different “big box” store outlets. Follow this manual's requirement in purchasing flue pipe and the flue pipe manufacturer's instructions and conform to all local codes. The following checklist is provided to assist in ensuring a home is prepared for installation:

- a) Country Flame Crossfire Corn stove.
- b) Country Flame or custom shroud to frame Crossfire stove around hearth.
- c) Flue pipe per site and local code requirements.
- d) Code approved power outlet @ 120 Volt, 15 amperes (dedicated circuit recommended).
- e) No extension cords between stove and electrical outlet.
- f) **Clean and dry certified CORN fuel.**

The Crossfire should be installed into a masonry fireplace or zero clearance fireplace on a level or slightly sloping floor angle as measured from the front to the rear of the hearth opening. If the Crossfire is sloped forward to ANY degree, bridging of CORN fuel may occur inside the hopper. Bridging will starve the fire and cause a flame out due to lack of fuel. Ensure the fireplace hearth is flat or sloping to the rear of the firebox.

If an exhaust flue system is run over ten feet, Country Flame requires its pellet stove products to be connected to a four-inch versus a three-inch flue pipe to vent the stove. Country Flame has designed a built-in clean out “T” on the back of the stove to assist in annual maintenance. This clean out T is bolted to the floor and is designed so that the exhaust flue connects to the stove on top of this clean out T. The Crossfire is designed for a 4 inch stainless steel flue pipe to be connected to this clean out T and will line the existing chimney. Insulating the flue liner is strongly recommended by Country Flame. Should a 3 inch stainless steel flue lined is to be used in a Crossfire installation; a 4 inch to 3 inch adapter will be required. Terminate the flue at the top of the chimney with a weather plate, proper termination cap, and support the flue liner weight. Once proper electrical power is connected to the Crossfire and an appropriate shroud is used to finish out the installation, the Crossfire install is complete.

STOVE CLEARANCES

The Crossfire minimum clearances must be maintained during installation. Failure to maintain proper clearances can create a hazardous environment that will lead to a house fire or endanger the occupants. A stove that is installed correctly and maintained properly will minimize operating costs. Country Flame recommends the use of a Hearth Industry Professional that is certified to install pellet-burning products. Check with the local dealer or contact Country Flame if there is any question about the installation, the installer, or the product being installed. Maintain the minimum clearances to combustibles shown in TABLE 3. Follow all chimney manufacturers' installation instructions when installing a chimney system. Inevitably there will be differences between the chimney manufacturer and Country Flame's stove clearances. Always utilize the largest clearance listed. Contact Country Flame or one of its local authorized dealers to resolve any questions. The Crossfire was designed for

installation into an approved masonry or zero clearance fireplaces, the use of single or double-wall flue pipe will not affect the clearance distance from the unit to any combustible materials.

DEFINED MINIMUM DISTANCES TO COMBUSTIBLES	CLEARANCE
A. UNIT TO SIDEWALL	7"
B. UNIT TO SIDE TRIM	7"
C. UNIT TOP TO TOP TRIM	9.25"
D. UNIT TOP TO MANTLE	9.25"
E. HEARTH FLOOR TO MANTLE	32"
F. NONCOMBUSTIBLE FLOOR PROTECTION, front	6"
G. NONCOMBUSTIBLE FLOOR PROTECTION, sides	6"

TABLE 3: REQUIRED MINIMUM CLEARANCES

SHROUD INSTALLATION

FIGURE 11 shows the Country Flame shroud, with standard black trim, mounted on the Crossfire. New home construction normally will not require a shroud kit because the fireplace opening can be finished out to exact Crossfire dimensions. For pre-existing installation, a shroud kit is recommended. Country Flame offers three variations of shroud kit a) standard, b) oversize, and c) custom shroud. The Crossfire is designed to accept the shroud to simplify installation. Each Crossfire shroud comes with installation instructions and required hardware. Optional color trim is available. Contact an authorized dealer for further description.

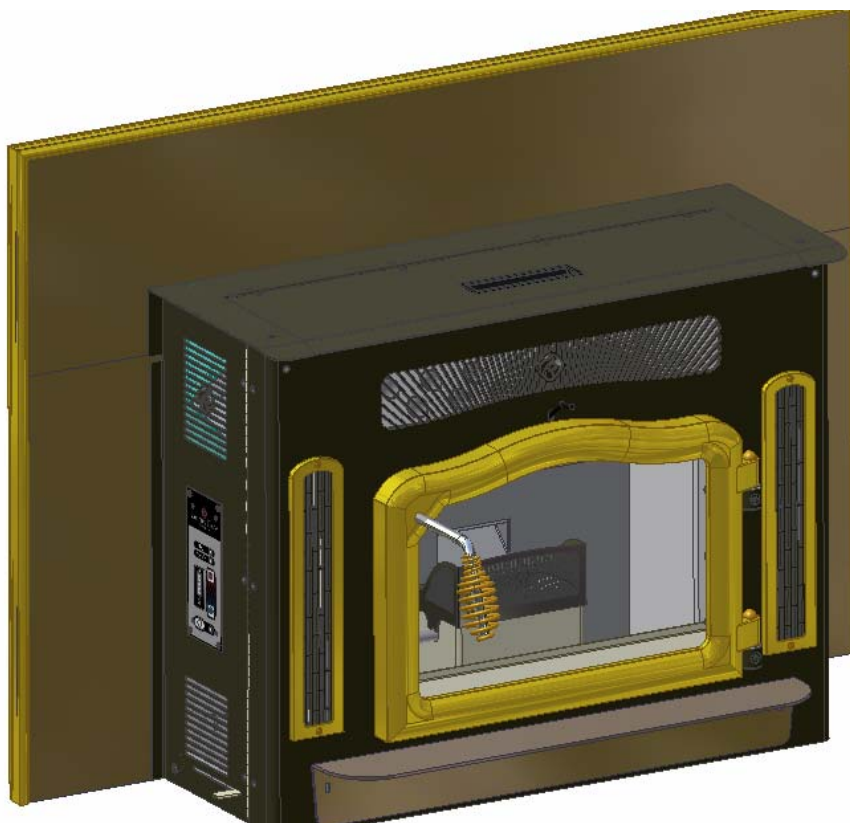

FIGURE 11: CROSSFIRE SHROUD

CHIMNEY

It is extremely important that a Crossfire stove be vented into a non defective, clean, and properly lined chimney. The chimney system must conform to all local building codes. In the event a masonry chimney is not used, a listed factory-built chimney suitable for use with solid fuels should be used. This listed factory-built chimney system must conform to ULC-S629 (Canada) or UL 103HT (United States.) Any chimney can and should be lined with a 3 inch (under 10 feet) or 4 inch (over 10 feet) stainless steel flue liner attached directly to the outlet pipe of the Crossfire stove. **DO NOT CONNECT ANY CROSSFIRE APPLIANCE TO A CHIMNEY FLUE SERVING ANOTHER APPLIANCE.**

FIGURE 12 and **FIGURE 13** illustrate both masonry and zero clearance chimney connections for both masonry and factory-built chimney applications. If installations require something different than one of these illustrated methodologies, please contact a local code official and a professional installer to ensure the proposed installation is code approved. All flue joints require 3 screws to secure the joints.

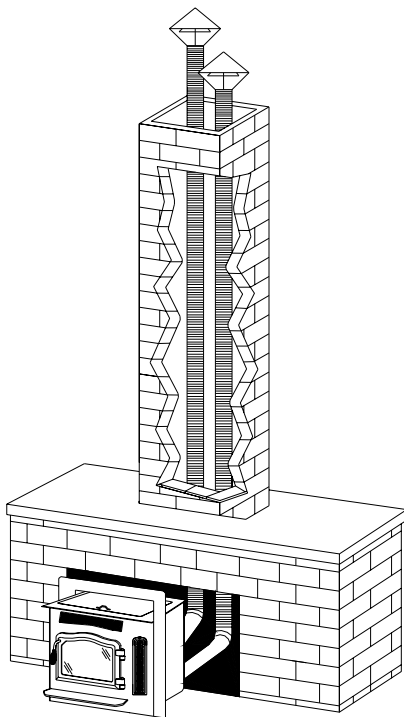

FIGURE 12: MASONRY CHIMNEY

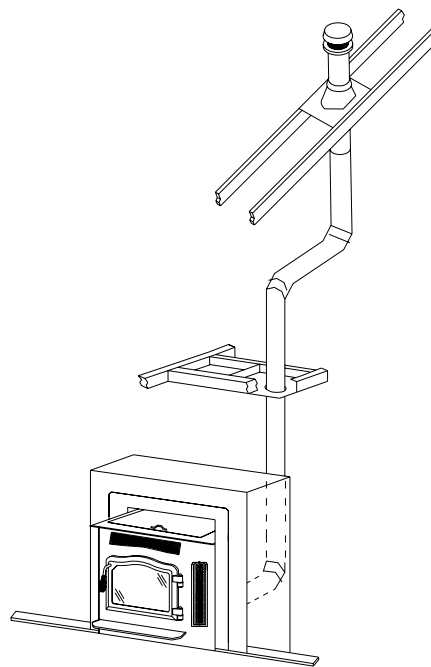

FIGURE 13: ZERO CLEARANCE

FACTORY-BUILT CHIMNEY

For any factory-built chimney installation, in conjunction with a Crossfire insert, the homeowner should refer to the chimney manufacturer's instructions. It is important that in addition to manufacturer's instructions, the homeowner must follow all national and local codes during the installation process.

The Crossfire insert clearances to combustibles materials, listed in TABLE 3 must be maintained. If local code allows, these distances can be reduced when acceptable shielding is provided. Consult a local code authority and professional installer to ensure that a specific installation meets proper code.

MASONRY BUILT CHIMNEY

Before connecting the Crossfire to a chimney, be sure to have the chimney inspected by a chimney professional and cleaned, if necessary. The chimney should have a liner that is free from cracks, deterioration, softening, or other damage that may prevent it from containing the byproducts of

combustion. In all cases, the flue must be relined with a listed liner system, such as HomeSaver Chimney Liner. If your masonry built chimney contains oversized flue tiles it must be relined to ensure proper draft. This means that a new, properly sized liner system must be installed before connection to the Crossfire stove is completed. Again, for 10 feet or less a 3 inch stainless steel liner can be used with the Crossfire. For lengths greater than 10 feet, a 4 inch stainless steel liner is to be used. It is also strongly recommended that these stainless steel liners be fully wrapped in insulation. This insulation will limit moisture buildup and ensure better performance of the Crossfire stove. Country Flame strongly recommends the use of smoke and carbon monoxide detectors when installing the Crossfire. Always refer to local codes and a professional installer to ensure proper installation.

FLOOR PROTECTION REQUIREMENTS

1. A Country Flame Crossfire insert may require a listed floor protector that is noncombustible. Refer to TABLE 3 on page 27 of this manual to ensure all clearances to combustible material are met during the installation of a Crossfire stove. Ensure that any noncombustible floor protection equals or exceeds $R = 1.5$ or greater. Refer to TABLE 3 for floor protector clearance requirements.
2. If a floor protector, different from the tested floor protector, is to be used, it must meet or exceed the requirements of the listed R-value of the tested floor protector. To convert alternate floor protectors to their respective R value use the following procedures:
 - a. Convert floor material specification to R-value.
 - i. R-value is given – no conversion is required.
 - ii. k-factor is given with required thickness (T) in inches: $R = (1/k) \times T$.
 - iii. C-factor given: $R = 1/C$.
 - b. Determine the R-value of the proposed alternate floor protector.
 - i. Use the formulas provided in STEP 2a to convert values not expressed as “R.”
 - ii. For multiple layers of material, add each R-value of each layer to determine the materials overall R-Value.
 - c. If the overall R-value of the alternate material is greater than the R-value tested material defined in STEP 1, then the alternate floor protection is acceptable.
 - d. **EXAMPLE:**
 - i. The tested material was $\frac{3}{4}$ -inch thick with a k-factor of 0.84.
 - ii. The R-value of the tested material was $R = (1/0.84) \times \frac{3}{4} = 0.893$.
 - iii. The proposed alternative floor protector is 4-inch brick material with a C-factor of 1.25 over $\frac{1}{8}$ -inch mineral board with k-factor of .29.
 - iv. The 4-inch brick material has a value of $R_{\text{brick}} = (1/1.25) = 0.80$.
 - v. The mineral board has a value of $R_{\text{mnbrd}} = 1/0.29 \times 0.125 = 0.431$
 - vi. Total $R_{\text{brick}} + R_{\text{mnbrd}} = 0.80 + 0.431 = 1.231$.
 - vii. Since the total R-value of the alternate example floor protector ($R=1.231$) is greater than the tested example floor protector ($R=0.893$), the alternate is acceptable.
3. Listed Floor Protector Definitions:
 - a. Thermal Conductance = $C = \text{Btu}/(\text{hr})(\text{ft}^2)(^{\circ}\text{F}) = \text{W}/(\text{m}^2)(^{\circ}\text{K})$
 - b. Thermal Conductivity = $k = (\text{Btu})(\text{inch})/(\text{hr})(\text{ft}^2)(^{\circ}\text{F}) = \text{W}/(\text{m})(^{\circ}\text{K}) = \text{Btu}/(\text{hr})(\text{ft})(^{\circ}\text{F})$
 - c. Thermal Resistance = $R = (\text{ft}^2)(\text{hr})(^{\circ}\text{F})/\text{Btu} = (\text{m}^2)(^{\circ}\text{K})/\text{W}$
4. Install in accordance with 24 CFR, Part 3280 (HUD).
5. **WARNING:** Crossfire insert stoves must always be placed on a listed floor protector if the existing floor where the stove is to be placed is made of any combustible material. Never allow

carpet to come in contact with any part of the Crossfire insert. Maintain clearances to combustibles as specified in TABLE 3, page 29 of this manual.

OUTSIDE AIR COMBUSTION

It is imperative that the installer and homeowner ensures that a minimum of at least eight square inches (fifty square centimeters) of outside air be admitted to the hearth room or directly to the Crossfire. If installation allows, the Crossfire fresh air intake should be connected through an exterior wall.

Provision for outside combustion air may be necessary to ensure that fuel-burning appliances do not discharge byproducts of combustion into the house. Guidelines to determine the need for additional combustion air may not be adequate for every situation. If in doubt, it is advisable to provide outside air.

Outside combustion air may be required if:

1. The Crossfire does not draw steadily, smoke rollout occurs, fuel burns poorly, or back-drafts occur whether or not combustion is present.
2. Existing fuel-fired equipment in the house, such as fireplaces or other heating appliances smell, do not operate properly, suffer smoke rollout when opened, or back-draft occurs whether or not combustion is present.
3. The home is equipped with a well-sealed vapor barrier and tight fitting windows or has any powered devices that exhaust house air.
4. There is excessive condensation on home windows in the winter.
5. A ventilation system is installed in the house.

If any of these or other indicators suggests that infiltration air is inadequate, additional combustion air should be provided from the outdoors to the Crossfire appliance. Outside combustion air can be provided to the appliance by the following means:

1. Direct connection: appliances can only use direct connection of outside combustion air if they are certified for this type installation. Follow the Crossfire instructions for direct connection of outside combustion air.
2. Indirect connection: for appliances not certified for direct connection of outside combustion air, outside air can be ducted to within twelve inches of the appliance.
3. Mechanical ventilation: if the house has a ventilation system (air change or heat recovery):
 - a. The ventilation system may be able to provide sufficient combustion make-up air for the Crossfire appliance.
 - b. The homeowner should be informed that the ventilation system might need to be re-balanced by a ventilation technician after installation of the Crossfire stove.

MOBILE HOME INSTALLATION

WARNING: DO NOT INSTALL A COUNTRY FLAME CROSSFIRE STOVE IN ANY MOBILE HOME SLEEPING ROOM.

WARNING: THE STRUCTURAL INTEGRITY OF THE FLOOR, WALL, CEILING AND ROOF MUST BE MAINTAINED DURING THE INSTALLATION OF A COUNTRY FLAME CROSSFIRE STOVE IN A MOBILE HOME.

WARNING: A CROSSFIRE STOVE INSTALLED IN A MOBILE HOME MUST BE COMPLETED IN ACCORDANCE WITH 24 CFR, PART 3280 (HUD).

WARNING: A CROSSFIRE STOVE MUST BE PERMANENTLY BOLTED TO THE FLOOR OF THE MOBILE HOME. (NON-COMBUSTABLE MATERIAL)

WARNING: A CROSSFIRE STOVE MUST BE ELECTRICALLY GROUNDED TO THE STEEL FRAME OF A MOBILE HOME.

MOBILE HOME RULES

1. Install only a HUD-approved laboratory tested stove in a mobile home. If the metal tag permanently affixed to a Corn burning stove does not specifically state; “mobile home approved to HUD Standard UM-84,” do not install the product in a mobile home. The Crossfire Model CF-04 is approved for use in mobile homes. Install all Crossfire stoves in accordance with 24 CFR, part 3280 (HUD).
2. A permanent (hard line) combustion fresh air duct system must be installed and connected from the outside of the mobile home directly to the combustion air inlet on a Crossfire stove.
3. A Crossfire stove must have a listed prefabricated chimney system installed in the mobile home. This chimney system must be properly connected and installed directly from the stove through the roof of the mobile home using only one manufacturer’s chimney products. Follow the chimney manufacturer’s installation instructions to the letter.
4. All mobile home stove installations or stove replacements require a permit to be obtained from the local code department and at least a final inspection before operation of the stove is authorized. Use only licensed contractors to perform the installation work. Further, an insurance representative should provide an approval document stating that the installation and inspection are in accordance with industry standards and therefore covered by the homeowner’s insurance policy.

MOBILE HOME CLEARANCES

1. Clearance is defined as the open space distance between any part of the stove or its flue connector and any combustible material, including but not limited to: walls, ceilings, trim moldings, furniture, word storage containers, or any other combustible item. Refer to the stove clearance section of this manual or the certification tag on a stove for minimum clearances that must be maintained during installation of a stove into a mobile home.
2. Use of an approved thermal barrier may allow for the reduction of no barrier minimum stove clearances. Remember that a wall (wood studs covered with sheetrock, even if that wall is covered with brick) is still considered combustible. Functional thermal barriers are made of hearth pads consisting of two ¼” sheets of mineral board or 24-gauge sheet metal spaced 1” from the combustible wall, with approved spacers that provide additional protection to the combustible wall. Refer to a hearth pad manufacturer’s instructions or the National Fire Protection Association Publication 211.

Do not violate minimum clearances with approved thermal barriers. Manville's CERAFORM 126 is an example of an approved insulated wall protector. This product has a K equal to .27 and is a half-inch thick. Total thermal resistance should exceed 1.5 for any material used to ensure proper thermal protection of a combustible wall.

MOBILE HOME STOVE ATTACHMENT

1. Install combustion air to the back of the Crossfire in all mobile home applications. The other end of the combustion air tube is to be installed through the mobile home floor or a wall. Ensure that snow or other material cannot prevent fresh air from entering the duct located outside the mobile home.
2. The Crossfire must be secured to the floor of the mobile home, as shown in FIGURE 14 and must be properly grounded to the steel frame of a mobile home.
3. Install a mesh screen or an approved fresh air cap on the outside of the mobile home combustion air tube. This cap will keep foreign material, birds, or small animals out of the fresh air system. Do not use mesh screen from windows as it has too small a hole.
4. If operation of the Crossfire stove causes room air starvation, dangerous fumes can be sucked into the mobile home from other vented appliances. **WARNING: DO NOT INSTALL ANY CROSSFIRE STOVE IN A SLEEPING ROOM.** Air starvation usually occurs: (a) because the combustion air intake is blocked, (b) because the stove door is left open or does not seal properly, or (c) due to strong exhaust fans being operated inside the mobile home. Always ensure that fresh air intake systems remain unblocked and ensure free fresh airflow. Contact your local Country Flame dealer for annual inspections.

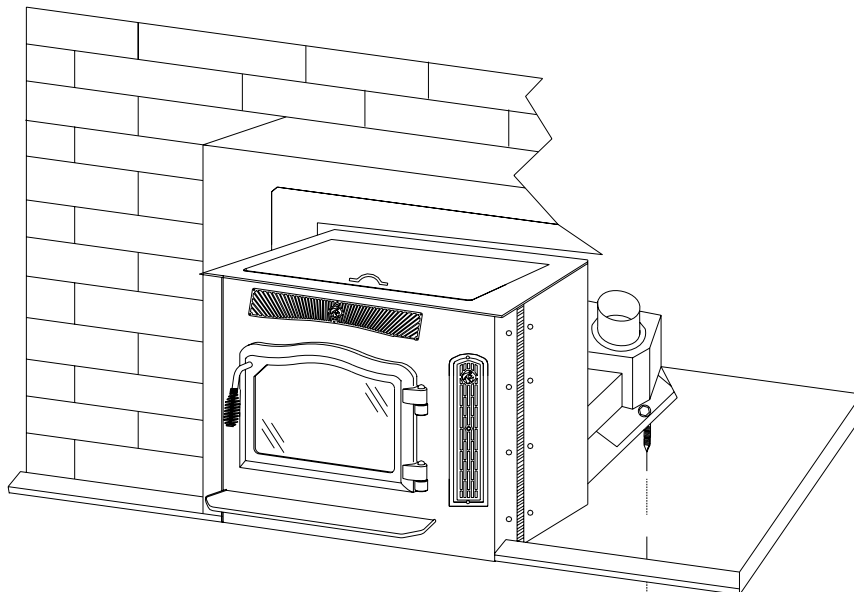

FIGURE 14: MOBILE HOME PEDESTAL INSTALLATION

MOBILE HOME FLOOR PROTECTION

1. A mobile home floor must be protected against stray sparks, radiant heat build up, or from damage during general use.
2. This floor protection must meet certain minimum requirements as a thermal barrier. Calculations are provided in this manual for determining if a floor protector meets minimum requirements for a mobile home installation.

3. At no time should a floor protector be placed on top of carpeting. Carpeting must be removed and the floor protection should sit directly on the uncarpeted portion of the mobile home floor. Floor protection should extend to the front, sides, back, and under the chimney connector as defined for a specific model listed in this manual. In the event there are floor protection questions, contact Country Flame or one of its local authorized dealers for assistance.

MOBILE HOME CHIMNEY AND DUCTS

1. ALL PELLETT VENTING systems should be composed of listed TYPE L or TYPE PL, factory-built flue pipe and components assembled in accordance with the manufacture's instructions for conveying flue gases from a listed pellet fuel-burning appliance to the outside atmosphere. Although a listed component does not guarantee a chimney fire will not occur, it is as close to ideal as industry standards provide today. Mobile home pellet stove and flue pipe restrictions are that: (a) regular thin walled stovepipe is not permitted, (b) roof systems cannot be weakened when installing a chimney or flue system, (c) a chimney cap and spark arrester are mandatory, and (d) the chimney must be strong enough to withstand normal area wind velocities.
2. There are many chimney manufacturers providing excellent products that meet government listing requirements. From single wall, to double wall, to triple wall chimney components, each type and brand meets many various application criteria. Further, each chimney manufacturer provides excellent written instructions on HOW TO install a chimney system. This information should aid the homeowner in ensuring a certified professional completes the job properly. If there are questions, contact Country Flame or a local authorized dealer. If additional information is required, a search of the internet will provide plenty of valuable information. An example of an informative and excellent chimney product manufacturer's website is www.duravent.com.
3. A complete chimney system should include a HUD approved spark arresting chimney cap, a storm collar, a roof flashing, an attic radiation shield (if needed), a chimney support box, a ceiling finish collar, and other parts required by site specific conditions. There will be clearance differences presented in both the stove and chimney manufacturers' product literature. ALWAYS use the larger clearance requirement when installing a pellet burning stove system into a mobile home.
4. A mobile home chimney system should serve only one pellet burning stove. The chimney system must extend at least 3 feet above the highest point on the roofline where it passes through the roof. The chimney system should be at least 2 feet higher than any part of a roof or building within a 10-foot clearance around the chimney. The minimum chimney vertical height is 8 feet and the maximum chimney vertical height is 30 feet as measured from the top of a specific Crossfire model stove to the chimney flue exit. REMEMBER: The structural integrity of a mobile home wall and roof must be maintained during installation of a Crossfire stove. Country Flame strongly discourages the removal or cutting of roof trusses or other structural components of a mobile home in order to install a stove. Consult local code.
5. To comply with over-the-road height limitations and to protect the chimney system and roof from damage remove all above roof chimney parts during transport of a motor home. Use only noncombustible material to seal all chimney system joints to prevent cold air leakage into a mobile home. Refer to local codes or consult with an authorized local Country Flame dealer to obtain the name of approved noncombustible sealants.
6. Many chimney manufacturers provide mobile home chimney kits. Mobile home chimney kits are not all-inclusive. A homeowner should consult with a certified professional. Additional chimney parts will be required to handle variations in local codes, site-specific mobile home issues, ceiling height, ceiling slope, roof pitch, attic insulation, attic height, and surrounding objects. Use a

certified professional to install a flue gas pellet venting system. Do not deviate from the pellet flue manufacturer’s installation instructions. Contact Country Flame or a local authorized dealer to resolve any questions or installation procedures. TABLE 4 shows the required components needed for a typical pellet flue pipe mobile home installation. Contact Dura-Vent or other authorized flue pipe dealers for the latest specifications and costs for mobile home pellet stove flue pipe parts or for a mobile home flue pipe kit from an authorized chimney dealer.

TABLE 4: MOBILE HOME (minimum) CHIMNEY SYSTEM REQUIRED PARTS

PART NUMBER	DESCRIPTION	QTY
3180	VERTICAL CHIMNEY CAP	1
3149	0/12 – 6/12 ADJUSTABLE ROOF FLASHING	1
3151 (ALTERNATE)	ROOF FLASHING, Flat (versus 3149)	1
3142	CEILING SUPPORT BOX, Fire Stop Spacer	1
3141 (ALTERNATE)	CATHEDRAL CEILING SUPPORT BOX, (versus 3142)	1
3160B	5 FOOT CHIMNEY SECTION	2
3179	STOVE PIPE ADAPTER (if needed)	1
CERAFORM 126	WALL PROTECTION (IF REQUIRED)	1
3145B	45 ⁰ ELBOW (if needed)	1
3159	STORM COLLAR	1

NOTE: The information provided in TABLE 4 and detailed in FIGURE 15 are for informational purposes. These corn flue pipe system parts may or may not be needed depending on site specific conditions found in the specific mobile home application. Consult a certified professional and insure that any installation meets all federal, state, and local building codes. Failure to follow the flue pipe manufacturer’s installation instructions will void Country Flame’s product warranty and can have an adverse impact on the homeowner’s insurance policy. Contact Country Flame or one of its local authorized dealers to resolve any questions about installation or parts usage.

FIGURE 15: MOBILE HOME CHIMNEY INSTALLATION

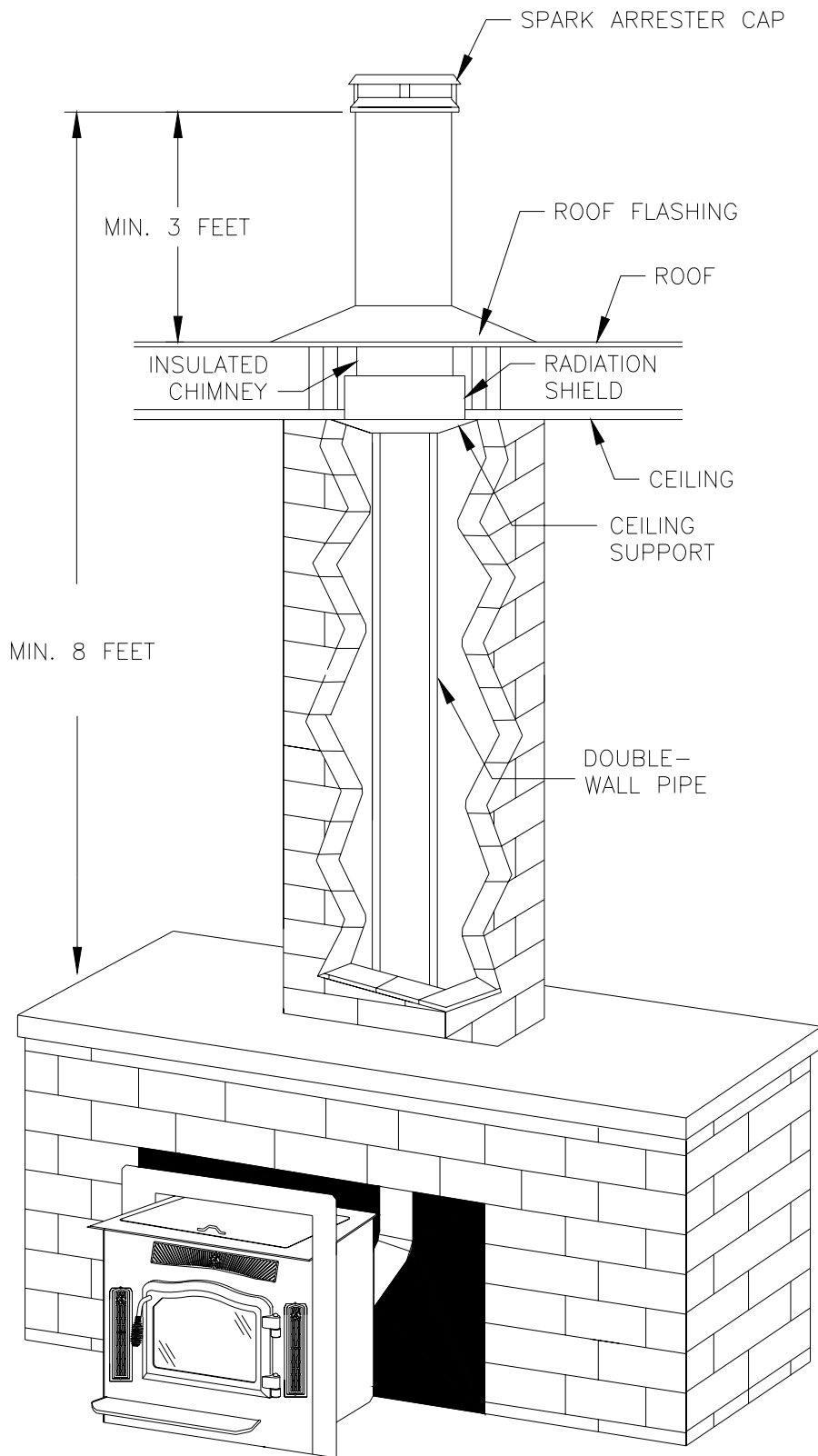

MAINTENANCE REQUIREMENTS

GENERAL REQUIREMENTS

The Crossfire Model CF-04 has minimal maintenance requirements; however, **failure to perform cleaning or maintenance items will lead to degraded performance and potential safety hazards for both the home and its occupants.** The Crossfire stove should not be operated routinely without thorough (as required) cleaning for consistent performance, depending on frequency of use.

The three most common maintenance chores will be:

- a) Refilling the hopper with fuel as needed.
- b) Cleaning the FIREBOX, BURNPOT, and glass as required for proper operation.
- c) Emptying firebox & burnpot ash to ensure ash does not interfere with proper operation.

Country Flame strives to use high quality low maintenance components in the Crossfire.

STOVE DOOR INSTALLATION

The Crossfire door has been mounted and checked for proper fit at the factory. If the door is removed for any reason, care must be taken in reinstalling the door to ensure proper alignment and fit. Setting the door is quite simple. Ensure the door is in the fully open position. Once done, align the female portion of the door hinge with the male portion of the stove hinge. Gently lower the door hinges over the stove hinge pin. Once the door hinges have been set, the door can be closed to check for proper fit. The Crossfire door installation should now be complete. To remove the door, simply lift up on the door from the stove hinges. Store the door in a secure place. If the door is left sitting, ensure that the door cannot fall and injure someone or damage the door or glass. The Crossfire door has been adjusted at the factory. If the door fit is not satisfactory, the homeowner can adjust the door using the hinge screws, refer to FIGURE 16.

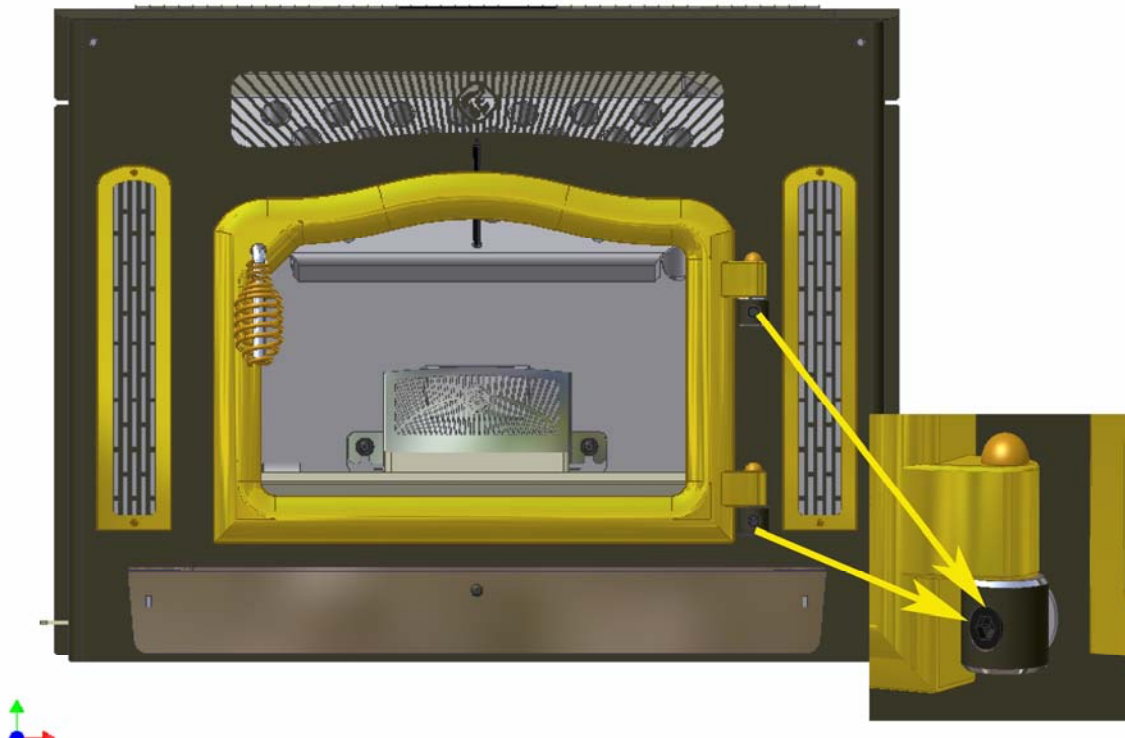

FIGURE 16: DOOR ALIGNMENT POINTS

STOVE DOOR ADJUSTMENT

The Crossfire door may require fine adjustment due to variations in the door, the gasket material, due to hinge wear, or to maintain a center-aligned appearance. The Crossfire door needs to remain airtight to ensure proper firebox operation. The Crossfire door can be adjusted up or down and left or right with the adjustable hinge pins as shown in FIGURE 16.

The door gasket can also be adjusted to improve on the airtight fit. To adjust the gasket tightness, simply rotate the door latch clockwise (tighten) or counterclockwise (loosen) one complete revolution or as necessary to adjust the gasket seal. A good test to evaluate proper door gasket seal is to lay a dollar bill against the stove frame and then close and latch the door. If gently tugging on the dollar bill does not dislodge it from the door, the seal is appropriate. In the event that a proper door gasket seal cannot be obtained, it may be time to replace the door gasket.

STOVE DOOR GLASS CLEANING

The Crossfire stove is designed with an air wash system that assists in keeping the door glass clean. If the Crossfire stove is operated continuously on low heat setting, the door glass will get dirty quicker than when a medium to high fire is fueling the firebox. If the operator wants the door glass to remain clean for the longest period of time, a high temperature fire must be maintained. This means adjusting the combustion air to obtain as blue a flame as possible without blowing pellets out of the burn pot. CAUTION: Do not clean hot glass. If glass requires cleaning, use an authorized stove glass cleaner on a cool glass. Contact Country Flame or one of its local authorized dealers to obtain a suitable glass cleaner. Regular household glass cleaners are not effective in cleaning creosote and other residue from the glass. DO NOT use abrasives such as steel wool or powder abrasives as they will permanently damage the glass. Once the glass has been scratched, complete replacement of the glass is required. Use only approved 1400°F high temperature stove ceramic glass to replace any cracked or broken glass.

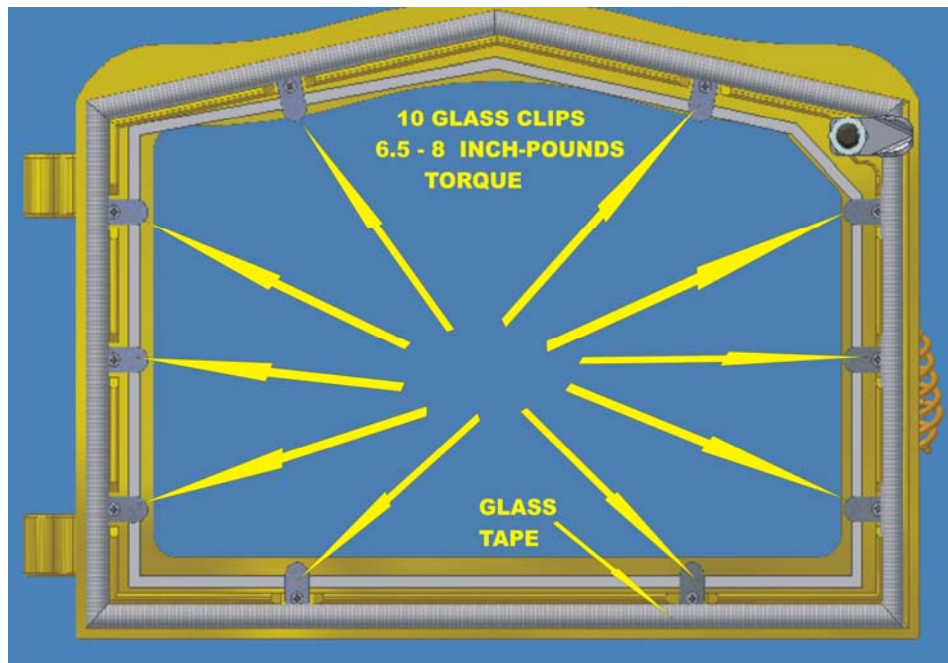

FIGURE 17: DOOR GLASS REPLACEMENT

GLASS REPLACEMENT

The glass used in the Crossfire stove is a 1400° F high temperature ceramic glass. If the glass should crack or break for any reason, it must be replaced with an equal or better grade ceramic glass. The use of tempered glass or ordinary glass IS NOT AUTHORIZED and its use is hazardous. Crossfire replacement glass can be purchased direct from Country Flame or one of its authorized dealers. See FIGURE 17 for securing points for

the door glass. Removal of these glass retaining clips can be accomplished with household tools. Order the necessary replacement screws or glass clips when ordering glass to ensure worn parts are replaced.

GLASS-CERAMIC SPECIFICATIONS

Manufacturer
Window Type

Euro Kera
Glass-Ceramic, Kera Lite®

KERA LITE® glass-ceramic has a thermal endurance far exceeding that of normal tempered glass. **KERA LITE®** is designed to operate at temperatures ranging from **-400⁰F to +1400⁰F**. Despite its superior thermal properties, **KERA LITE®** stove windows should be treated with care. This glass-ceramic can still be scratched or broken by mechanical abuse. When cleaning the window, use only non-caustic, non-abrasive cleaners. The Crossfire stove uses **KERA LITE®** glass-ceramic that is 0.197 inches thick +/- 0.008 inches. Country Flame custom cuts each **KERA LITE®** glass at its factory to fit the Crossfire stove. If problems occur with glass or any replacement part is needed, contact Country Flame or a local authorized dealer for assistance in ordering the necessary parts.

CAUTION: Do not attempt to clean hot glass. Do not abuse, strike, slam shut, or operate the Crossfire stove with any broken glass in the appliance.

GASKET REPLACEMENT

Remove the doors from the unit. Place the doors, face down on a protective surface to ensure no marring or scratching occurs during gasket replacement. To replace the Thermoglass™ knitted rope and tape gasket, first remove all of the old material and gasket cement. Use a putty knife or other sharp instrument to assist in removal. Use caution to prevent injury when removing old material. It is important to ensure the doorframe area is totally clean before installing the new gasket cement and material. The gasket must fit tight against the door frame in order to ensure a proper airtight seal when the stove is being operated. Apply gasket cement to the gasket channel per instructions provided with the gasket kit. Once the cement has been properly applied, install the new gasket. Both gasket and gasket cement are available from your authorized Country Flame dealer. The following table defines the gasket material used in the Crossfire stove:

<u>Gasket</u>	<u>Length</u>	<u>Quantity</u>	<u>Dimensions</u>
Around glass	4.25 feet each	1	¾" wide by 1/16" thick tape
Doorframe	5 feet each	1	¾" rope, high density
Ash drawer	37 inches	1	½" wide by 1/8" thick tape

CROSSFIRE CLEANING

A Crossfire stove will require general cleaning, depending on frequency of use. During heavy use, daily cleaning of the firebox will be required and less frequently during light use. Allow the ash in the fire box to completely cool before removing the waste with an industry approved ash vacuum.

The stove should be professionally cleaned twice a season if heavy use (daily use) is expected. A certified chimney sweep will have the proper tools to make short work of semi-annual cleaning. Country Flame has designed the Crossfire to make semi-annual cleaning as simple as possible. In fact, Country Flame designed the Crossfire so that it does NOT require removal from the fireplace in order to be properly cleaned. The following figures show how to access the cleaning ports on the Crossfire. By understanding how to thoroughly clean your Crossfire, the operator can maintain the stove in tip-top shape to ensure proper combustion and high efficiency. If questions do arise, do not hesitate to contact your Country Flame Dealer for additional information.

In order to thoroughly clean the exhaust chamber, the Crossfire has two cleaning ports that provide access to the exhaust chamber. In order to gain access to these clean-out ports, the hearth plate must be removed from the front of the Crossfire. FIGURE 18 shows the hearth plate removed from the stove. There is one screw, located in the front center of the hearth plate that must be removed before the hearth plate can be lifted up and out of its location.

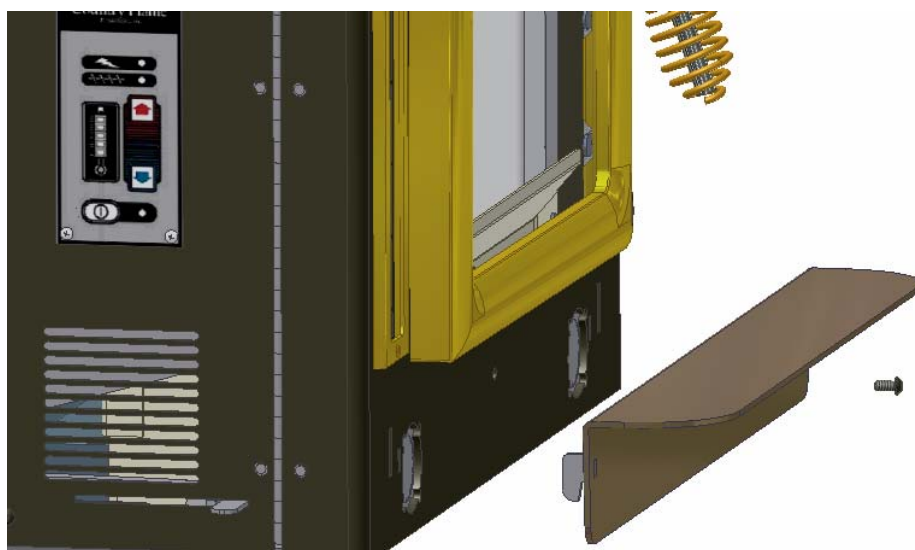

FIGURE 18: HEARTH PLATE REMOVAL

Note that the hearth plate has two tabs located on the left and right side. Once the screw has been removed from the center of the hearth plate, the hearth plate can be lifted (gently tapped) upward to remove it from its locked position

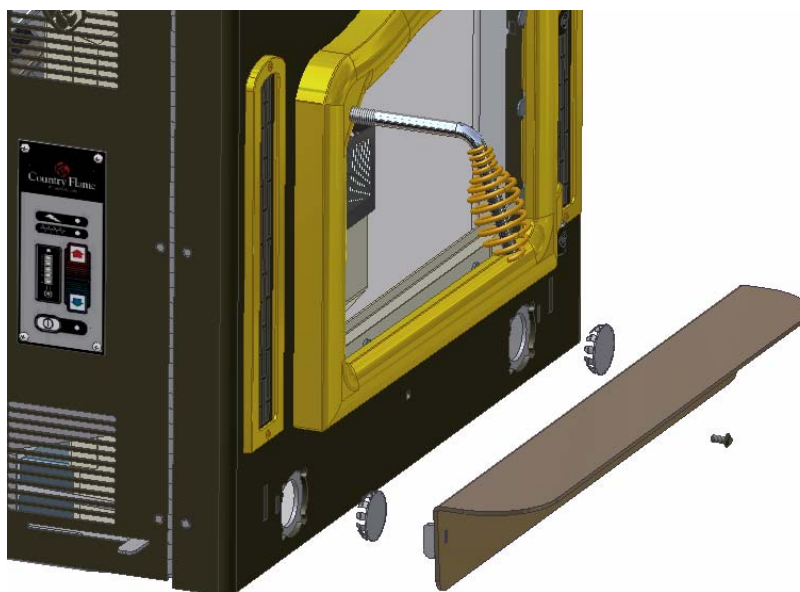

FIGURE 19: CLEAN-OUT PORT CAP REMOVAL

Once the hearth plate has been removed and set aside, along with the screw, the clean-out port caps can be removed. FIGURE 19 shows the cap locations behind the hearth plate. Once these caps are removed, the clean-out ports are now accessible. An industry approved ash vacuum can be used to remove any ash or debris that has accumulated in the exhaust chamber to be removed. Removal of this ash and debris will allow the stove to draw more air and thus burn with a greater efficiency. Failure to clean out these areas over

a period of use can lead to one or both exhaust chambers becoming blocked and thus causing the stove to burn inefficiently. FIGURE 20 shows an x-ray view into the clean-out port of the right side of the Crossfire. This right side clean-out port allows access to the right side exhaust chamber and underneath the exhaust fan itself. There is no access to the chimney connector and clean out T box but a powerful vacuum will be able to suck considerable amount of ash from the chimney box thus assisting in proper maintenance of the stove.

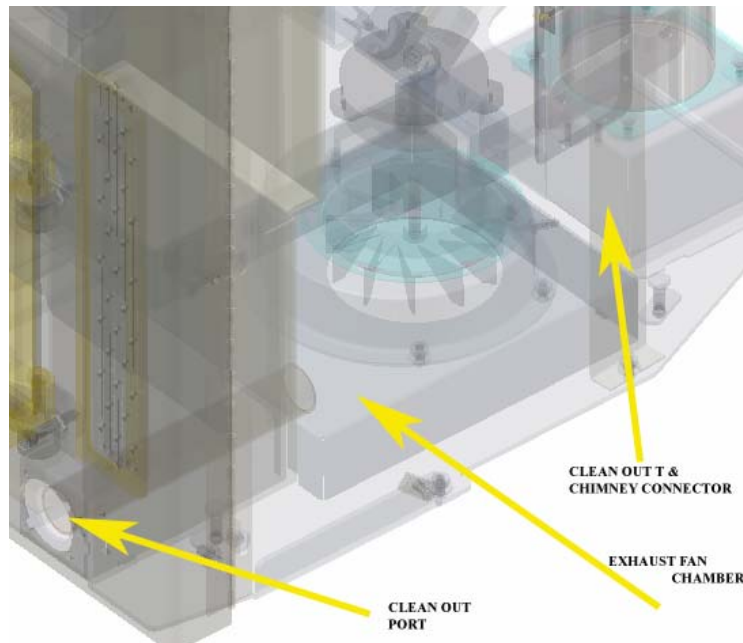

FIGURE 20: X-RAY VIEW OF RIGHT SIDE CLEAN-OUT PORT

In the event a Crossfire system requires cleaning of the chimney to remove debris or ash, the Crossfire will require removal from its hearth installation in order to remove the chimney connector. This should not be necessary except under the most extreme operating conditions or in the event an animal has obtained entrance to the top of the chimney and built a nest inside the chimney. Again, the homeowner should contact a certified chimney sweep as they may have the equipment to clean the chimney from roof level thus eliminating the requirement to remove the Crossfire from its hearth installation.

Whatever time is spent maintaining and cleaning the Crossfire should be viewed as improving both the burn efficiency and the heat output of this product.

APPENDIX A: TROUBLESHOOTING GUIDE

Shut off the power to the unit and allow it to cool off when performing cleaning and maintenance.

	PROBLEM	SOLUTION
Ignition	Fire does not start.	Ensure proper amount of pellets and starting gel are in burn pot.
	Stove does not switch on	The starter fire in the firepot has not ignited or is not burning properly. Using gloves carefully open the doors and relay the pellet fire. Wait 8-10 minutes for the pellets to burn well, before restarting the system.
Fuel	If Corn/Pellets contain a large amount of “fines” (foreign matter) or sawdust	You may want to screen/sift Corn/Pellets before use if they contain a large number of cobs and stalk pieces to reduce problems and maintenance.
	No fuel in Firepot	Ensure that auger motor and auger flight is being turned. The auger may need to be primed if it has run empty or has become blocked. The stirring rod can be rotated by turning on the switch.
	Hard build-up on the firepot base	Un-burnt corn may cause “clinking” (hard brittle deposits found in the bottom of the firepot). Screen your fuel to make sure that there is no foreign matter
	Blockage in the auger.	If the corn is not feeding into the firepot at the normal rate the auger may need to be cleaned. This may be due to fines or debris caught in the auger flight.
	Stove Performance	If your stove is not working effectively
	If your stove is not generating enough heat	Fines or dust in the corn can cause the unit not to burn properly or can cause a buildup in the drop tube and restrict the flow of corn. Clean the auger and fuel supply.
	Stove not performing effectively	Clean the Heat Exchanger System, as it may be clogged and blocked.
	Stove not getting enough air	Check to ensure that the fresh air intake is clear and unobstructed.
	Stove Heat not adjusting	Allow time between changing heat settings for the stove to adjust both fuel and air to the new heat setting.
	Restricted flue gas flow	Fly-ash will collect in the exhaust venting system and restrict the flow of the flue gases. Incomplete combustion, such as occurs during start-up, shut down, or incorrect operation of the stove will lead to some soot formation which will collect in the exhaust venting system. The exhaust vent should be checked frequently and cleaned at least once a season.
	Room Air Blower does not activate	Please contact your Country Flame Dealer as your stove may need maintenance

APPENDIX A: TROUBLESHOOTING GUIDE (CONT'D)

	Stirring Paddles do not turn	The chain drive for the stirring paddles needs to be checked after the first 8 hours of operation as it can loosen. It is located by opening the left side door (the one with the control panel). Inspect the tension of the chain. It should have approximately 1/2" play. If the chain is too loose, adjust the chain drive motor by loosening the 4 bolts securing it and sliding it back until there is proper play in the chain. Re-tighten the bolts securely. This should be checked monthly or if you notice the stirring paddles not turning or binding.
Fire Goes out	Ash Build Up	Empty ash as required, to prevent the build up of ash under the firepot blocking the air flow to the fire pot putting the fire out.
	Fire goes due to ash build up	Do not leave viewing door open for more than 1-2 minutes or you may have to restart fire. Remove ash wearing proper gloves.
	Build up of Corn	Your Firepot may need additional cleaning as extended burning on the high setting may cause a build-up of corn
Stove Smokes	Your Corn/Pellet Stove Smokes	Your fuel may be damp or you may be using the incorrect fuel.
	Your Corn/Pellet Stove Smokes	You have used the incorrect starter fluid. Only use the approved pellet starter gel. Your Country Flame Dealer can advise you on where to find this.
	Your Corn/Pellet Stove Smokes	Check that the chimney is clean and free of soot and fly-ash build-up. Your stove exhaust system works with a negative combustion chamber pressure and a low positive chimney pressure. It is very important that the exhaust system be completely airtight and properly installed.
Cleaning	Cleaning is messy and difficult	Clean the Heat Exchanger more frequently. This cleaning procedure should be done daily. If buildup is allowed to go unattended, cleanup will be much more difficult and the efficiency of your stove will be adversely affected.
Glass	Glass Breaks	Use care not to slam or strike door, this could result in glass breakage. If glass is broke or cracked, DO NOT operate the stove. Repairs must be made.
Doors	Luster on Gold Doors Fades	Always use an approved glass cleaner (i.e. Windex, Glass Plus) and a lint free soft cloth to polish the door frame. Do not use abrasives like steel wool, brass polish or adhesive cleaners like comet, as these will scratch the finish. If the Gold Doors are scratched they will have to be replaced or returned to Country Flame for refinishing. This is expensive and during this time you will not be able to use your stove.
	Doors are not airtight	Check door alignment for proper seal. Adjust door hinges as necessary to ensure a good airtight seal. The doors may need new gasket material. Contact a local Country Flame dealer.

APPENDIX B: MAINTENANCE GUIDE

Shut off the power to the unit and allow it to cool off when performing cleaning and maintenance.

<p>Regular Cleaning</p>	<p>Removing and cleaning the Firepot</p>	<p>The firepot can be removed by removing 2 bolts. Slide the keeper sleeve off of the stir rod gear shaft exposing the linkage. Rotate the stir rod until the slot is vertical. Now lift the firepot and the stirring rod out of the firepot holder. To replace, reverse the procedure. The stir rod can be rotated by operating the control board. See control board instructions.</p>
	<p>Removing “Clinkers”</p>	<p>A clinker or ash build up on the bottom of the firepot may need to be removed for proper operation. NOTE: For your Safety, only remove clinkers from stove when unit is cool. Wear gloves and eye protection.</p>
	<p>Soot and Fly-ash Build Up</p>	<p>The ash must be emptied every day, (or as required). If the ash is not emptied regularly, ash will build up under the firepot and block proper air flow to the fire pot putting the fire out. When the stove is cold, the firepot can be pulled out and removed for a thorough cleaning. Also, check the drop tube (where the corn drops into the firepot) for blockage.</p>
	<p>Thorough Cleaning</p>	<p>Remove ash when it is COOL. Use an industry approved ash vacuum for removing ash. Dump the ash into a fire safe covered container. The firepot may be lifted out (first remove bolts) and remove the stir rod. Dumb and clean the firepot as needed. Vacuum the inside of the COOL unit and replace all parts BEFORE starting operation again.</p> <p>Remove the “I” plugs located on each side of the firebox housing. Insert the vacuum hose into each of these COOL access ports. Completely vacuum and then replace “I” plugs. Air leaks will not allow the stove to burn properly.</p>
	<p>Cleaning the Heat Exchanger.</p>	<p>A sliding plate fits over the fifteen tubes of the heat exchanger. The sliding plate is attached to a small rod protruding through the front of the stove just below the louver vent. Push the rod to the back of the exchanger and then pull forward to the front, several times. This will effectively remove ash and debris from the surface of the heat exchanger. Performing this step often will ensure that cleaning is an easy task. This cleaning procedure should be done daily. If buildup is allowed to go unattended, cleanup will be much more difficult and the efficiency of your stove will be adversely affected. CAUTION: Cleaning rod may be hot! Use a fireplace glove to protect your hand when using the cleaning rod to avoid getting burned!</p>

APPENDIX B: MAINTENANCE GUIDE (CONT'D)

	Cleaning the Glass	To clean glass, use a mild non-abrasive cleaner when the stove and glass are COOL . Creosote builds up on glass quicker when a fire is burned at lower heat settings. DO NOT use abrasive cleaners on glass. (Glass may crack if subjected to cold liquid cleaners while the glass is still hot. Using cleaner on hot glass may also cause burns, emit fumes and the glass is more likely to stain.)
	Cleaning the Gold Doors (optional feature)	Doors should be wiped down regularly to ensure the luster of the door system lasts. Always use an approved glass cleaner (i.e. Windex, Glass Plus) and a lint free soft cloth to polish the door frame. Do not use abrasives like steel wool, brass polish or adhesive cleaners like comet, as these will scratch the finish.
	Door Air Wash	Periodically clean out the door air wash (a groove at the bottom of the door). This air wash directs air over the glass door to minimize soot buildup on the door. (Ash Vac. with small hose attached)
General/Yearly Maintenance	Exhaust Venting System	After using your stove, you will observe small particles of fly-ash. The fly-ash will collect in the exhaust venting system and restrict the flow of the flue gases. Incomplete combustion, such as occurs during start-up, shut down, or incorrect operation of the room heater will lead to some soot formation which will collect in the exhaust venting system. The exhaust venting system should be inspected at least once every year to determine if cleaning is necessary.
	Air Intakes	When starting to use the stove at the beginning of the season, check to ensure that the fresh air intake is clear and unobstructed.
	Oiling the Room Air and Exhaust Blowers	If supplied with oil ports, the room air & exhaust motors will need to be oiled at least once per season with PROPER oil. Locate the oil ports on either the side or top of the units and add three drops of oil. This simple step will greatly increase the life and serviceability of your unit.
	Checking the tension on the Chain Drive of the Stirring Paddles.	Locate the chain drive by opening the left side door (control panel side). Chain tension should be approximately 1/2" play. If the chain is too loose, adjust the chain drive motor by loosening the 4 bolts securing it and sliding it back until there is proper play in the chain. Re-tighten the bolts. The chain should be checked monthly.
	Inspecting the Door Gasket	This is done by taking a 2" long strip of paper and shutting the door on it. Then pull the paper to test the gasket pressure. You should have to pull the paper from the door. Check all around the gasket. If the paper slides out easily or falls out, the gasket needs to be replaced. Country Flame recommends that both the door and glass gaskets be replaced at the same time.

APPENDIX B: MAINTENANCE GUIDE (CONT'D)

	<p>Replacing the Door / Glass Gaskets</p>	<p>To replace the gaskets, remove the door by lifting it straight up off its hinge pins and laying it face down on a soft surface. Remove the door gasket (you may need to use pliers) and then remove the glass retaining clips and remove glass. Strip off old gasket around glass and clean glass well. Clean out old stove gasket material from gasket track. Once the door and glass are clean, apply gasket material to glass surface and return glass to door, securing with clips (Use care not to over-tighten). Then apply a generous bead of gasket cement into the track. Position the NEW gasket into track and gently press into door. Trim off any excess gasket and wipe away excess cement. Let the cement set 24 hours before placing door back on unit and using the unit. Gasket material and cement may be obtained from your dealer.</p>
	<p>Replacing the Glass</p>	<p>Remove the door gasket (you may need to use pliers) and then remove the glass retaining clips and remove glass. Replacement glass should be 0.200" (5mm) thick. Overall size of the glass is 16" (405mm) wide by 11" (279mm) high, cut to an irregular shape to fit the door front. Your unit uses Euro Kera or a similar ceramic type high temp glass. Do not use any other than recommended glass type in this unit. Replacement glass may be obtained from your dealer. Clean out old stove gasket material from gasket track. Once the area is clean, apply gasket material to new glass surface and return glass to door, securing with clips (Use care not to over-tighten).</p>
	<p>Adjusting the Doors</p>	<p>The doors of your Crossfire Stove may need some adjustment due to shipping vibrations, jarring during installation and extended use. It is important that the Crossfire door fit properly and remain airtight. Periodically check the alignment of the doors. To adjust the door, loosen the Allen bolts in the hinge and adjust the door accordingly. When completed, use a piece of paper between the door and the stove to ensure a proper seal. The paper should not pull out easily once the door is closed and latched.</p>

APPENDIX C: TECHNICAL SPECIFICATIONS

Fuel Type:	#2 Yellow Shelled Corn Fuel (CLEANED) Moisture Content: 14% or less (10- 12% preferred) Heat Content: 10,000 Btu/lb* Ash Content: 3% maximum Bulk Density: 40 lb./cubic ft. min	Hardwood Pellet Fuel A.P.F.I. residential fuel Heat Content: 8200 BTU/lb Ash Content: 1% max Moisture Content: 8% max Size: 1/4" to 3/8" diameter 1.5" long max Fines: 1% max through 1/8 th screen
-------------------	---	---

Hopper Size:	72 pounds corn or 55 pounds wood pellets	
Flue Size:	4" recommended. If less than 10 feet use of 3 inch pipe is approved.	
Flue Type:	PL double wall vent with stainless steel inner liner	
Air Inlet:	3 inch by .15 inch walled steel pipe	
Auger Type:	1 1/8" cup Auger Feed System	
Controls:	Country Flame <i>Intelli-Choice</i> Control Board	
Electrical:	120 Volts, 2.4 Amp, 60 Hz	
Measurements:	CROSSFIRE HEIGHT (at front)	22.5"
	CROSSFIRE DEPTH (from shroud)	14.0"
	CROSSFIRE WIDTH (rear)	26.0"
	CROSSFIRE WIDTH (at shroud mount)	25.5"
Weight :	STOVE WEIGHT	220 POUNDS
Clearances:	UNIT TO SIDEWALL	7"
	UNIT TO SIDE TRIM	7"
	UNIT TOP TO SIDE TRIM	9.25"
	UNIT TOP TO MANTLE	9.25"
	HEARTH FLOOR TO MANTLE	32"
	NONCOMBUSTIBLE FLOOR PROTECTION (front)	6"
	NONCOMBUSTIBLE FLOOR PROTECTION (sides)	6"
Shroud Measurements:	SHROUD WIDTH (standard)	42.0"
	SHROUD HEIGHT (standard)	30.0"
	SHROUD WIDTH (oversized)	48.0"
	SHROUD HEIGHT (oversized)	32.5"

*BTU/lb can vary depending on the moisture content of the corn.

APPENDIX D: CROSSFIRE THEORY OF OPERATION

BURN PHASE

Multiple heat lights indicate the control panel burn phase. There are five lights (4 yellow and one red) used to indicate the relationship to the system's heat settings. Pushing the control panel's HEAT LEVEL switch will cause a heat light to cycle one level up from Heat 1 through Heat 5. Once the Heat 5 setting has been reached, if the HEAT LEVEL button is pushed again, the heat setting will cycle over again starting at Heat 1. The operator controls the heat output of the stove by utilizing Heat 1 through Heat 5 settings. Heat 1 setting provides the lowest heat output from the system and the longest time between refills of the fuel hopper. Heat 5 provides the maximum heat output from the system and the shortest time between refills of the fuel hopper. Changing any heat setting up or down by one increment will cause a delayed (it takes time for both the fuel and air adjustments to impact the burn chamber) increase or decrease in the heat output of the system. Changing any heat setting up or down by two or more increments will require an increased amount of time before the burn rate of the stove stabilizes.

The control system automatically adjusts to the requested heat settings without further intervention of the operator. NOTE: The control panel display immediately reflects the final heat setting requested by the operator regardless of how many incremental changes occur but the operator should remember that it takes "time" for the stove to stabilize to the new heat setting.

COOL DOWN PHASE

Any time the system is switched off by pressing the *Intelli-Choice* Control Board on/off switch until the power light turns red during normal stove burn operations, the control board will ensure the system will revert to the cool down phase. During the cool down phase the room air and exhaust fans will be operated at full speed. The fuel feed (auger) motor will cease to operate thereby ensuring minimal time for the burn phase to be extinguished. This cool down process will continue until such time as the control system senses that the stove has been properly cooled down.

APPENDIX D: THEORY OF OPERATION (cont'd)

FAULT PHASE

The fault phase is indicated by all lights except the Country Flame logo light flashing on and off at a rapid pace. This event signifies that the control board has encountered an improperly operating system and requires intervention by either the operator or a properly trained service technician. In the event that the fault phase continues to flash lights, the operator should not try any repairs except those listed below without contacting their dealer or an authorized and properly trained service technician. Country Flame has made every effort to ensure the safety of the homeowner through proper use of this system. Any attempt to modify or circumvent the safety features of this product is prohibited by the manufacturer. In the event that the fault phase does not reset with the manufacturers recommended procedures, please contact your local authorized Country Flame service representative.

RESET CONDITION

Reset Condition #1 requires the system to properly proceed through cool down phase. By allowing cool down to occur the control panel will automatically shut off the system. In order for system shut off to occur all electronic controls must sense safe system temperatures. In the event “safe temperatures” are not sensed by the system, the control panel will continue to operate in the cool down phase until such time that safe temperatures are achieved or the operator intervenes. In order to perform a “hot restart” from the cool down phase, Reset Condition #2 must be followed.

Reset Condition #2 assumes the operator has shut down the system and has now decided that a restart of the system is required. In order to perform a restart the operator must press and hold the up heat (red) arrow for a minimum of 15 seconds. This will return the system to startup phase. Please refer to startup phase for specifics. All procedures in the startup phase should be followed in order to ensure burn phase is properly achieved from the hot restart phase. **NOTE: A HOT RESTART CAN ONLY BE ACHIEVED FROM A COOL DOWN PHASE.** In the event of a “fault phase” no hot restart can be initiated.

SYSTEM MAINTENANCE

There are two functions built into the control board that can be used to assist with maintenance or troubleshooting a system. These two control board functions are:

- a) Prime State
- b) Manual Control

The Prime State is utilized upon installing a new stove or after a fuel bin (hopper) has been depleted of fuel. The prime state can be entered by pressing and holding the on/off switch for a minimum of 15 seconds. By holding the on/off switch on for 15 seconds or more, the auger light (green) will be turned on and the heat lights will be sequenced from lowest to highest light being consecutively turned on to signify the auger being filled with fuel. This prime state will remain on for a maximum of 10 minutes or until the operator presses the on/off switch at which time the system will revert to the off state. The prime state is utilized only for filling the auger with fuel and can only be utilized from an “off state.”

The Stir Rod is controlled by the control board in one of two states: (a) when the system is shutdown, and (b) when the system is in the burn phase. The purpose of the stir rod is to mix the fuel and air to ensure a more efficient burn. During normal burn phase operation, the control board controls the motion of the stir rod. The operator can press both the blue (down) and red (up) heat arrows to turn the stir rod manually. This manual

movement facilitates removal of the stir rod for maintenance or for facilitating starting a fire by rotating the stir rod to enhance air flow during a fire's startup.

In order to manually turn the stir arm, the up and down (red and blue) heat arrows must be simultaneously pressed while the control is in only the **OFF PHASE** or the **STARTUP PHASE**. As long as the up and down heat arrows are held in either the off or startup phase, the stir rod will rotate. Upon releasing either of these arrows, the stir rod rotation will stop turning. **WARNING:** Keep hands or loose clothing away from the stir pot.

APPENDIX E: COMBUSTION BASICS

An understanding of **Combustion Basics** will assist in resolving problems with a variety of fuels, changing product and environmental conditions during the operational life of a stove. Just exactly what are pellet or corn stove products suppose to do?

PROVIDE A CONVENIENT PLACE FOR STORAGE OF FUEL.

PROVIDE FOR CONTROLLING IGNITION, FUEL, COMBUSTION AIR

PROVIDE CONTROLLING HEAT FROM FIREBOX TO HEAT EXCHANGER.

CONTROL SYSTEM TEMPERATURE.

OPERATE SYSTEM EFFICIENTLY TO MINIMIZE WASTE.

ENSURE SAFETY FEATURES PROTECT USER AND SURROUNDING AREA.

Some standard terminology is required in order to discuss Combustion Basics. This terminology is reasonably standard throughout the different industries. The following terms should be part of a stove owner's vocabulary and a basic understanding of these items is a must in maintaining a stove system:

Ash content: Refers to the non-combustible materials in a fuel, which reduce the heating value per unit of weight.

Carbon

Dioxide: A heavy colorless gas that does not support combustion and dissolves in water to form carbonic acid.

Carbon

Monoxide: A colorless, odorless, poisonous gas produced by incomplete combustion. Incomplete burning of wood pellets will create this gas.

Combustion: Combustion refers to the rapid oxidation of fuel accompanied by the production of heat, or heat and light. Complete combustion of a fuel is possible only in the presence of an adequate supply of oxygen. Chemical reaction between a fuel and oxygen that usually takes place in air. Combustion is commonly referred to as burning.

Combustion

Air: The amount of air required inside the combustion chamber to create a burn. Combustion air, for this manual, is defined as the amount of air required to ensure 100% burn of all fuel present in the burn chamber.

Combustion

Efficiency: Calculated measurement (in percent) of how well the heating equipment is converting a specific fuel into useable heat energy at a specific period of time in the operation of a heating system.

Combustion

Temperature: The temperature required to ensure the release of flammable vapors. To sustain combustion, the heat evolved must maintain this temperature to provide a constant supply of vapors.

Excess Air: Any air added to the combustion process above the theoretical value defined as 100% efficiency. A combustion system operated exactly at the peak burn efficiency ratio has a high probability that some of the oxygen in the combustion air will not get paired up with the fuel. Adding **excess air** ensures that a percentage of additional air is available to ensure complete burn of all fuel. . In addition, a little excess air provides a cushion against the fuel-air ratio drifting over into the rich (excess fuel) range. **With time, all combustion systems will tend to burn richer (that is more fuel than air.) The big enemy that creates a richer burn is dirt.** Dirt is more likely to accumulate in the air system rather than in the fuel system. The combustion and makeup air fans, in addition to everything else within a stove, are giant vacuum cleaners, sweeping in any dust, dirt and vapors that happen by. In time, the systems air path becomes partially obstructed, starving the system for air and causing the fuel-air ratio to become rich. Excess air ensures that complete combustion can occur at all times regardless of changes in environmental variables.

Ignition

Temperature: The temperature at or above which a substance will combust.

Pyrolysis: The second stage of ignition during which energy causes gas molecules given off by a heated solid fuel to vibrate and break into pieces.

Room Air: Air that is passed through a stove's heat exchanger tubes which elevates the room air temperature and thereby delivers heat to a living space.

CORN COMBUSTION BASICS

In a normal corn pellet combustion process, water is first boiled out of the fuel. Then volatile matter and fixed carbon matter are released in the combustion process and later burned to create heat. Any remaining product left behind in the burn process is defined as ash. FIGURE 18 illustrates the combustion process.

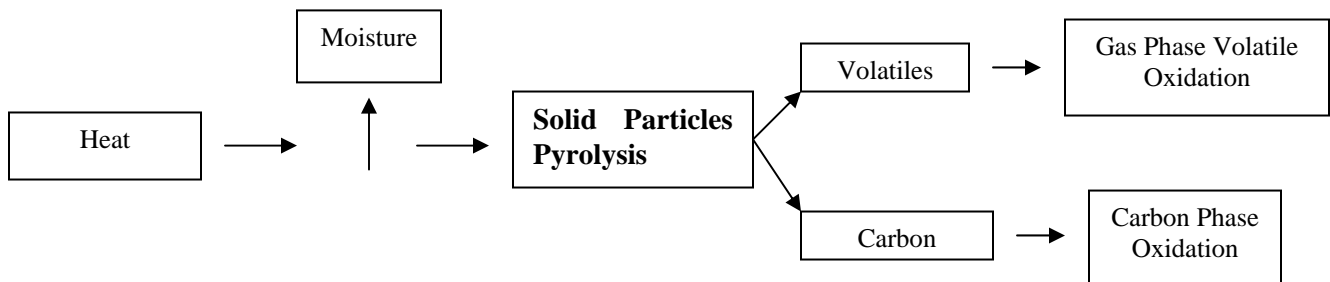

FIGURE 18: CORN COMBUSTION PROCESS

The obvious advantage of Corn or wood pellets over conventional chopped wood logs is the consistency of the fuel both from a size and moisture content. Nature has done a great job of making field corn a palletized fuel that can have even more energy than wood pellets. These palletized fuels burn more efficiently than their wood log counterparts. The heat generated in the burn process, once combustion is achieved, sustains the process as more fuel is added. As the gases burn, the pellet stove's firebox temperature can achieve temperatures exceeding 1,000° Fahrenheit. The list below gives a sample of ignition temperatures for some of the carbon and volatile matters released when wood is burnt:

<u>COMBUSTIBLE</u>	<u>FORMULA</u>	<u>IGNITION TEMP (° F)</u>
Fixed Carbon	C	765 – 1115
	Volatiles	
Hydrogen	H ₂	1076 – 1094
Methane	CH ₄	1202 – 1382
Ethylene	C ₂ H ₄	1008 – 1018
Benzene	C ₆ H ₆	1364
Ethane	C ₂ H ₆	968 – 1166
Carbon Monoxide	CO	1191 – 1216

Note that all **ignition temperatures** fall between 950° F through 1400° F for volatile matter. All visible flames emitted during a wood pellet fire come from the ignition of volatile matter. Good combustion occurs when the fuel vapors are thoroughly mixed with the combustion air. Mixing ensures that fuel molecules come in contact with oxygen fuel molecules. There must be an abundant amount of oxygen molecules available to react with the fuel molecules or an incomplete burn will occur. **NOTE: The fuel-air mixture must at all times exceed the combustion temperature as well as exceed the ignition temperature if a burn is to be sustained.** There must be adequate time for the reaction to proceed to completion (complete burn.) It is commonly stated that good conditions for combustion are defined as the THREE T's:

Turbulence	Temperature	Time
-------------------	--------------------	-------------

It requires turbulence in the fuel-air path to ensure that fuel and air molecules are thoroughly mixed to sustain the burn process. In addition, it takes a certain amount of temperature, defined as Ignition Temperature to sustain the burn. It takes a certain combustion temperature to ensure volatile and carbon matter is released from the fuel that will then combine with the oxygen in the air further adding to the heat. This entire combustion process takes time to occur and is self-sustaining only if all conditions are met for the fuel being burnt.

Heat is obtained from a stove by the thermal radiation that occurs from the burning wood pellets. Although a fairly complex phenomena to define, the heat radiated from the fire is a very strong function of the local (burn pot) temperature and the overall combustion temperature that is maintained within a stove's burn chamber. A relatively minor combustion temperature increase in a pellet stove can produce a significant amount of increased heat output. NOTE: The reverse of the preceding statement is also true. That is, if too much heat is pulled from the combustion chamber via the heat exchanger tubes, the combustion temperature can drop rapidly thus causing a "burn out." Burn out occurs once the combustion chamber temperature drops below the critical "ignition temperatures" required of the different fuel components. Wood pellets, because of their low combustion temperature ensure an ample supply of volatile and carbon matters available for continued ignition. However, for other types of fuel, such as corn, it is important that the homeowner understand the complexity of this principle and how environmental variables can affect the combustion chamber, combustion temperature, and ignition temperatures. Once a burn chamber's temperature begins to fall below critical ignition temperatures, the heat required to sustain the combustion temperature can also be lost and the fire will go out.

As a final note, the two basic stages of corn burning are:

- a) Somewhere around 1100° F the corn fuel particles have combined with oxygen molecules and released the majority of the available energy. Some gases will still not have reached ignition temperature and at this critical stage, if too much heat is removed from the combustion chamber, no more fuel will be burnt. All remaining fuel will simply exhaust through the system as unburned material.
- b) At temperatures around 1500° F the remaining gases and tars will burn off in the combustion chamber. This final combustion yields an additional 10 to 20% additional heat energy and gives a very clean final exhaust from the product.

Corn pellets, as compared to wood logs, enhance the amount of energy released during the burn cycle because of the uniformity of product, the reduced moisture content, and the variation in materials used to produce the wood pellet. These variations allow the turbulence in the burn system to ensure a better agitation of fuel with air and a more rapid and efficient burn. As other biomass fuels are utilized, optimum mixes of pellets will ensure clean burning, reduced emission systems are available that compete favorably in the consumer market.

The homeowner must be aware that as technology evolves, all stove manufacturers will strive to control more of the variables that might adversely affect the combustion process. In addition, stove manufacturers will strive to optimize the efficiency of the products burn process. It is the homeowner's responsibility to understand not only the particular product but also how environmental issues beyond the control of both the manufacturer can affect a product's burn process. This understanding will make trouble diagnosis less time consuming and more accurate for all parties involved in maintaining the product in a reliable manner to the satisfaction of our mutual customers.

APPENDIX F: REPLACEMENT PARTS

REPLACEMENT PARTS

<u>Part Number</u>	<u>Description</u>	<u>Number per CROSSFIRE</u>
CF04-P72	BURN POT SCREEN	1
CB-74	STIR ROD ASSEMBLY	1
CF04-A51	BURN POT ASSEMBLY - CORN	1
PP-353	EXHAUST MOTOR ASSEMBLY	1
PP-355	ROOM AIR MOTOR ASSEMBLY	1
PP-352	VACUUM SENSOR SWITCH	1
PP-347	250 ⁰ F OVER TEMPERATURE SENSOR	1
PP-12	110 ⁰ F EXHAUST/ROOM AIR SENSOR	1
PP-182	OWNERS MANUAL	1
PP-989	AC RECEPTACLE	1
NPS-1005C	<i>Intelli-Choice</i> CONTROL BOARD	1
PP-1029	WIRING HARNESS	1
PP-40	DOOR FRAME ONLY	1
PP-87-NC	DOOR ROPE GASKET	1
40-0000-05	CLEAN OUT PLUGS	2

APPENDIX F: REPLACEMENT PARTS (cont'd)

REPLACEMENT PARTS

<u>Part Number</u>	<u>Description</u>	<u>Number per CROSSFIRE INSERT</u>
CF04-A24	4" CHIMNEY CONNECT BOX	1
PP-535	AUGER MOTOR ASSEMBLY	1
PP-27	VACUUM HOSE	1
PP-88	HOPPER GASKET TAPE	1
PP-48	NON-ETCHED DOOR GLASS W/TAPE	1
PP-525	ETCHED DOOR GLASS W/TAPE	1
PP-107-G	SIDE TRIM, GOLD	2
PP-107-N	SIDE TRIM, NICKEL	2
PP-107-B	SIDE TRIM, BLACK	2
PP-185	SIDE TRIM, CUSTOM	2

APPENDIX G: LABELS

REPLACEMENT LABELS

<u>Part Number</u>	<u>Description</u>	<u>Number per CROSSFIRE INSERT</u>
--------------------	--------------------	------------------------------------

PP-483	CAUTION LABEL	1
--------	---------------	---



PP-484	CAUTION LABEL	1
--------	---------------	---



APPENDIX G: LABELS (cont'd)

REPLACEMENT LABELS

<u>Part Number</u>	<u>Description</u>	<u>Number per CROSSFIRE INSERT</u>
--------------------	--------------------	------------------------------------

PP-486	ELECTRICAL LABEL	1
--------	------------------	---

