

MODEL 21 NON-CATALYTIC UNIT

With

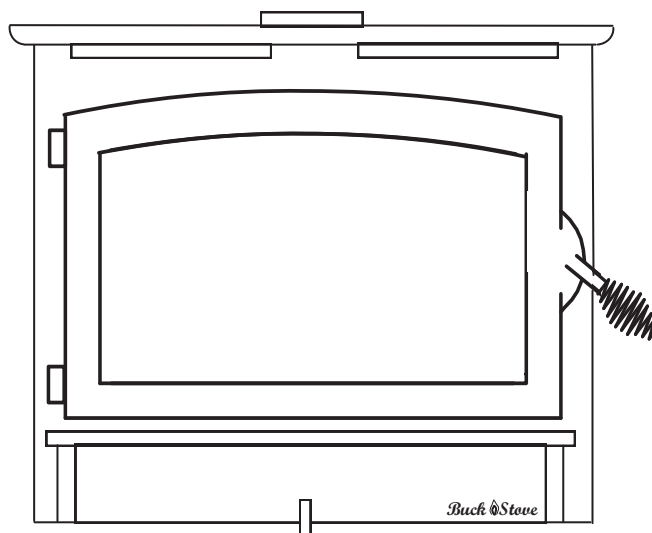

Motor



FIREPLACE INSERT & FREESTANDING

FEATURES

PREPARATIONS
OPERATION

INSTALLATION
MAINTENANCE

SAFETY

SAFETY NOTICE

IF THIS HEATER IS NOT PROPERLY INSTALLED, A HOUSE FIRE MAY RESULT. FOR YOUR SAFETY, FOLLOW THE INSTALLATION INSTRUCTIONS. CONTACT THE AUTHORITY HAVING JURISDICTION (SUCH AS MUNICIPAL BUILDING DEPARTMENT, FIRE DEPARTMENT, FIRE PREVENTION BUREAU, etc.) CONSULT BEFORE INSTALLATION TO DETERMINE THE NEED TO OBTAIN A PERMIT. KEEP THESE INSTRUCTIONS FOR FUTURE USE.

LISTED BY:



PFS/TECO, COTTAGE GROVE, WI

MANUFACTURED BY NEW BUCK CORPORATION
200 ETHAN ALLEN DRIVE
P.O. BOX 69
SPRUCE PINE, N.C. 28777
www.buckstove.com

Revised November 2021

TABLE OF CONTENTS

Important Instructions.....	2
Stove Parts Identification.....	3
SECTION I: Introduction	4
Chimney Heights	5
SECTION II: Masonry Insert Installation.....	6
Floor Protection	7
Mounting Trim Panels	8-9
Masonry Insert Installation options	10-11
SECTION III: Pre-Fab Insert Installation.....	13
SECTION IV: Residential Freestanding Installation.....	14
Out Side Air Installation.....	15
Floor Protection	16
Residential Installation	
A. Vertical Exit Using Single Wall Pipe /Listed 2100° UL 103 HT chimney w/out Close Clearance/Pipe Shield.....	17
B. Vertical Wall Exit Using Single Wall Pipe and Elbow /Listed 2100° UL 103 HT Chimney and T-BOX assembly w/out Close Clearance/Pipe Shields	19
Residential and Mobile Home Freestanding Installation (See Page 12) For Out Side Air Installation.	
C. Vertical Exit Using DVL Close Clearance Pipe /Listed 2100° UL 103 HT chimney w/out Close Clearance/Pipe Shields	21
D. Vertical Wall Exit Using DVL Close Clearance Pipe ,and Elbow /Listed 2100° UL 103 HT Chimney and T-BOX assembly w/out Close Clearance/Pipe Shields	23
E. Vertical Exit Using DVL Close Clearance Pipe /Listed 2100° UL 103 HT chimney with Close Clearance/Pipe Shields	25
F. Vertical Wall Exit Using DVL Close Clearance Pipe ,and Elbow /Listed 2100° UL 103 HT Chimney and T-BOX assembly with Close Clearance/Pipe Shields	27
SECTION V: Alcove Installation	31
Floor Protection	32
Alcove Installation Clearances	33
Installation of Close Clearance Shields	35
Wood Heater Safety.....	37
SECTION VI: Operation and Efficiency	38
Guide To Burning Qualities of Wood.....	39
Replacement Motor, Thermostat, Rheostat Installation	40-42
SECTION VII Maintenance: Brick Layout	43
Secondary Air Tube Replacement / Baffle Board Replacement	44
Door Gasket Replacement	45
Check Chimney / Cleaning Heater / Care of Glass Door	46
Troubleshooting.....	48-49
Replacement parts.....	49-50
LIMITED WARRANTY	

INSTALLATION AND OPERATION

IMPORTANT INSTRUCTIONS

WARNING

THESE UNITS GENERATE A LOT OF HEAT, SO TREAT THEM WITH CARE. **HOT WHILE IN OPERATION.** KEEP CHILDREN, CLOTHING AND FURNITURE AWAY. CONTACT MAY CAUSE SKIN BURNS. READ ALL INSTRUCTIONS BEFORE INSTALLING AND USING THE APPLIANCE. FAILURE TO FOLLOW INSTRUCTIONS MAY RESULT IN PROPERTY DAMAGE, BODILY INJURY OR EVEN DEATH. SAVE THESE INSTRUCTIONS FOR FUTURE REFERENCES.

- The New Buck Corp. non-catalytic systems have been tested to UL 1482 Standards and certified by PFS/TECO.
- **When burning any unit or appliance that combusts fuel for heat, such as coal, oil, wood or natural and (L.P.) liquid petroleum gas, we highly recommend use of smoke and carbon monoxide detectors in your home. Correctly place monitors in those areas that are expected to produce CO. Consult with your local fire safety officials to learn more.**
- **This wood heater needs periodic inspection and repair for proper operation. It is against federal regulations to operate this wood heater in a manner inconsistent with operating instructions in this manual.**
- Early signs of carbon monoxide poisoning resemble flu, with headaches, dizziness and/or nausea. If you have these signs, heater may not be working properly. Get fresh air at once!
- Install and operate your units according to instructions provided in this manual. Local building codes may apply; therefore, contact your local building inspector or fire marshal for necessary installation requirements and permits which may go beyond these instructions. The authority having jurisdiction should be consulted before installation to determine the need to obtain a permit. Contact your insurance company for coverage and installation inspection.
- If appliance is installed in permanently manufactured homes:
DO NOT INSTALL IN SLEEPING ROOMS.
- The Model 21 is approved for use in specified Pre-Fabricated fireplaces (ZCF's). Use the list on Page 13 or contact your dealer for additional units.
- Examine the masonry fireplace and chimney prior to installation of the fireplace accessory to determine that the construction meets the minimum fireplace construction requirements illustrated in the instructions, that it is free from cracks, loose mortar, creosote deposits and other blockage or other signs of deterioration.

CAUTION

DO NOT USE MORE THAN ONE STOVE TO A CHIMNEY. DO NOT USE A FLUE INTENDED FOR A GAS APPLIANCE. DO NOT CONNECT THIS UNIT TO A CHIMNEY FLUE SERVING ANOTHER APPLIANCE. DO NOT CONNECT TO ANY AIR DISTRIBUTION DUCT OR SYSTEM.

EPA COMPLIANCE STATUS

This manual describes installation and operation of the **New Buck Corporation Model 21** wood heater. This heater meets the U.S. Environmental Protection Agency's Emission limits for wood heaters and is in compliance with 2020 particulate emission standard. Under specific test conditions, this heater has been shown to deliver heat at rates ranging from approximately 11,079-28,901 BTU/hr for the Model 21. Efficiency was calculated using CSA B415-1.10 stack loss method. A weighted average was used to calculate the overall efficiency across all of the 4 burn rate categories using the higher heating value (HHV).

MODEL 21 WOOD STOVE IDENTIFICATION

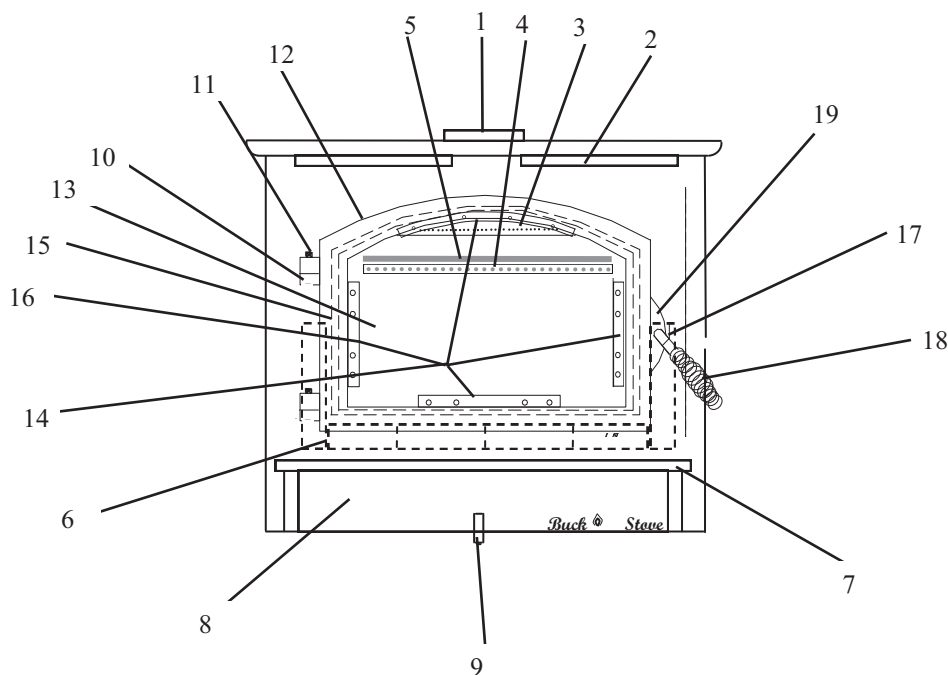

- | | |
|--|------------------------------------|
| 1. 6" Flue Exit | 15. Door Gasket |
| 2. Warm Air Outlets | 16. Door Glass Gasket |
| 3. Air Wash and Screen | 17. Door Handle |
| 4. Secondary Air Tubes | 18. Spring Handle |
| 5. Top Baffle Board | 19. -Door Latch |
| 6. Firebrick | -Door Latch Screw |
| 7. Hearth Extension and Hearth Trim | -Door Handle Bushing |
| 8. Cover Door | -Door Handle Spacer |
| 9. Primary Air Control | -Door Latch Flat Washer |
| 10. Hinge Block | -Door Latch Screws (Phillips Head) |
| 11. Hinge Pins | -Door Latch Screws (Allan Head) |
| 12. Cast Door | |
| 13. Door Glass | |
| 14. Glass Clips Small; Side, Top, Bottom | |

CAUTION

YOUR CHIMNEY OR FLUE MUST BE CORRECTLY SIZED. A CHIMNEY OR FLUE THAT IS TOO SMALL OR LARGE IN DIAMETER, OR TOO SHORT, CAN CAUSE YOUR STOVE TO SPILL SMOKE WHEN DOOR IS OPENED.

SECTION I

INTRODUCTION

Your new MODEL 21 is a non-catalytic unit designed to meet the most stringent emissions standards without the use of a catalytic combustor. This effect is achieved through the use of secondary air which is mixed with primary air in the unit's firebox.

For peak performance, we suggest the use of hard seasoned natural wood, loading wood length way from front to rear.

NOTE: Soft woods such as pine, create more creosote, clogging of chimney and produce a less efficient burn performance.

You should not burn trash or garbage, artificial or paper logs, gift wrapping, treated or painted wood or any type of coal.

**DO NOT USE CHEMICALS OR FLUIDS TO START THE FIRE.
DO NOT BURN GARBAGE OR FLAMMABLE FLUIDS."**

The primary air, which is controlled by the user, burns the wood. Secondary air is admitted into firebox through secondary air tubes at top of the firebox. This secondary air burns impurities in the smoke released from initial wood burning. The temperature necessary for this combustion is maintained through the firebrick refractory. If any more technical information is necessary, contact your local dealer.

A factory-built prefabricated chimney may be used for your unit when installed in compliance with the manufacturer's specification and uniform building code.

CHIMNEY HEIGHTS

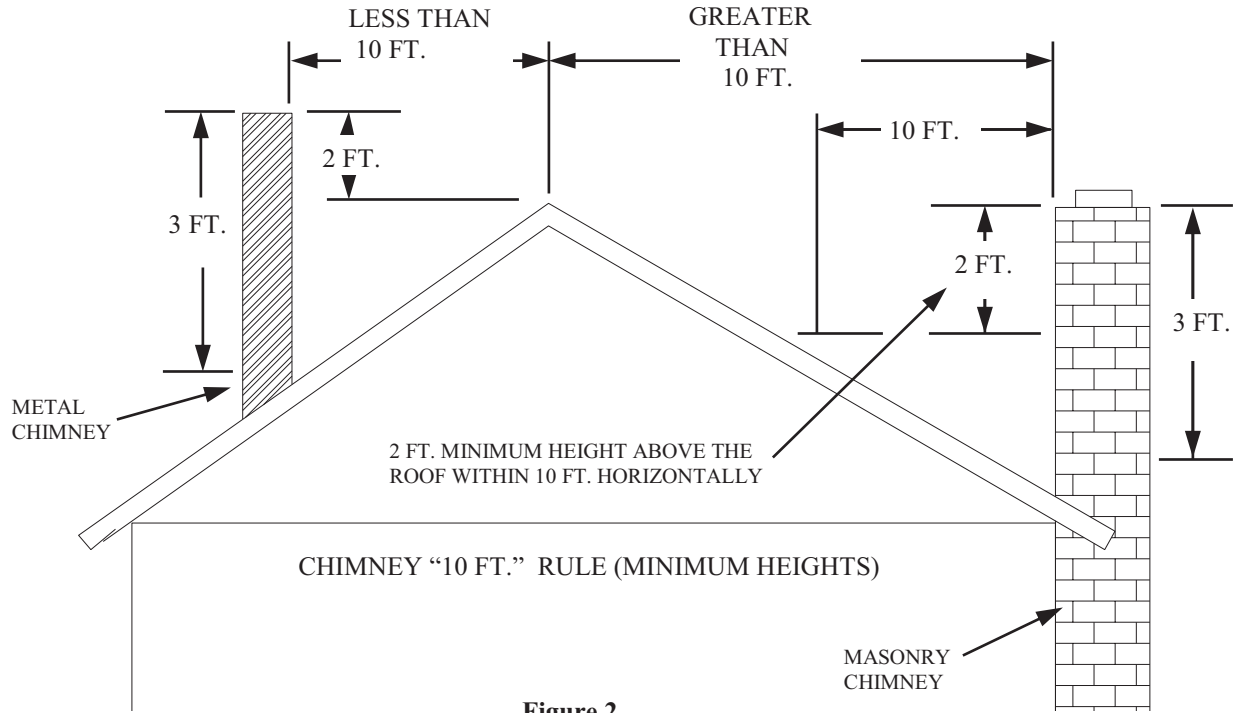
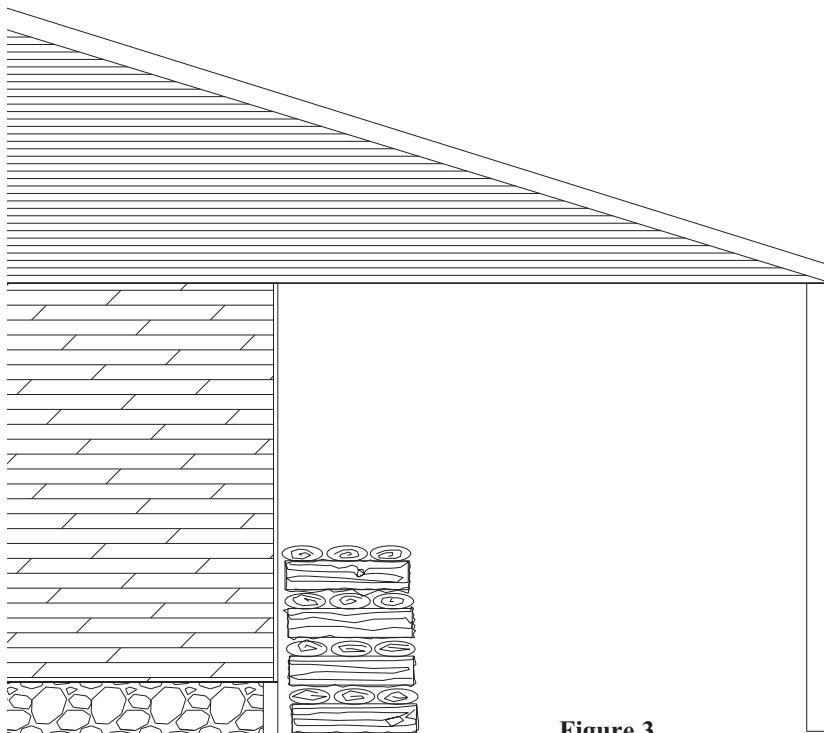

Figure 2

NOTE: MINIMUM CHIMNEY HEIGHT 15 FT.

HOW TO STACK WOOD



Stack wood in criss-cross pattern under a shelter to allow air flow to dry wood and to keep wood from rain. Green wood may have 50-60% moisture content. Wood seasoned outside uncovered may have 40% moisture content. Wood properly seasoned in a covered environment will have less than 20% moisture content.

Figure 3

SECTION II

MASONRY INSERT INSTALLATION

The Model 21 may be installed using an all masonry fireplace built in accordance with the Uniform Building Code and National Fire Protection Association (NFPA). The first step in this type of installation is to determine the acceptability of fireplace and chimney for use with a woodstove. Both construction and condition of fireplace are important considerations when installing a woodstove. The chimney should extend at least 3' above roof and at least 2' above any point of the roof within 10'. (See Page 5, Figure 3).

CAUTION

REMEMBER TO HAVE YOUR CHIMNEY INSPECTED FOR LEAKS AND BLOCKAGE **BEFORE** YOU INSTALL YOUR STOVE. DO NOT CONNECT THIS UNIT TO A CHIMNEY FLUE SERVING ANOTHER APPLIANCE.

MINIMUM CLEARANCES TO FLOOR AND COMBUSTIBLES

MINIMUM CLEARANCE MASONRY INSERT

MODEL 21

A. Side Wall Combustible	25"
B. Front Floor Protector	16"
C. Side Floor Protector	8"
D. Side Wood Trim	17"
E. Top Wood Trim	17"
F. Mantel or Brackets	25"

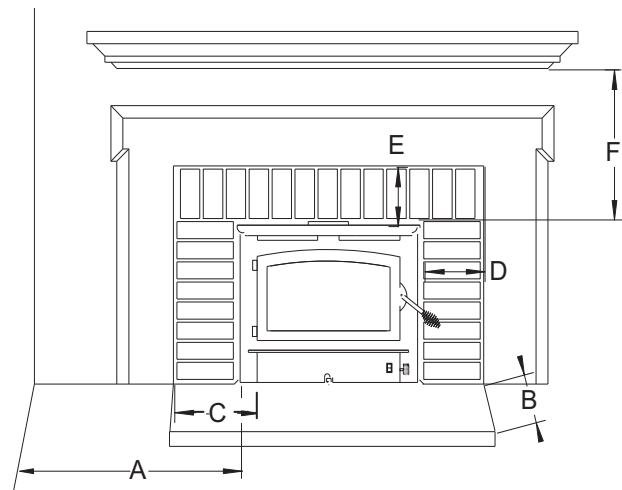

Figure 4

1. The hearth must be of masonry construction and must extend a minimum of 16" in front of firebox opening and a minimum of 8" to either side of the firebox opening. (See Figure 4).
2. If there is not minimum hearth protection from the front of firebox opening and front of masonry hearth, a floor protector must be used in front of hearth to protect combustible materials. The floor protector must be 3/8" minimum thickness non-combustible material or equivalent. (See Page 7).

Floor Protection:

When installing freestanding heater, a floor protector must be use. Floor protector must be 3/8” minimum thickness non-combustible material or equivalent.

How to use alternate materials and how to calculate equivalent thickness

An easy means of determining if a proposed alternate floor protector meets requirements listed in the appliance manual is to follow this procedure:

1. Convert specification to R-value:
 - R-value is given—no conversion is needed.
 - K-factor is given with a required thickness (T) in inches:
C-factor is given: $R=1/C$
2. Determine the R-value of the proposed alternate floor protector.
 - Use the formula in step (1) to convert values not expressed as “R”
 - For multiple layers, add R-values of each layer to determine the overall R-value.
3. If the overall R-value of the system is grater than the R-value of the specified floor protector, the alternate is acceptable.

Example:

The specified floor protector should be 3/4” thick material with a K-factor of 0.84.

The proposed alternate is 4” brick with a C-factor of 1.25 over 1/8” mineral board with a K-factor of 0.29.

Step (a): Use formula above to convert specification to R-value. $R= 1/K \times T = 1/0.84 \times .75 = 0.893$

Step (b): Calculate R of proposed system. 4” brick of $C=1.25$, therefore $R_{brick} = 1/C = 1/1.25 = 0.80$ 1/8” mineral board of $K = 0.29$, therefore $R_{min.bd.} = 1/0.29 \times 0.125 = 0.431$

Step (c): Compare proposed system R of 1.231 to specified R of 0.893. Since proposed system R is greater than required , the system is acceptable.

Definitions:

$$\text{Thermal conductance} = C = \frac{\text{Btu}}{(\text{hr})(\text{ft}^2)(\text{°F})} = \frac{\text{W}}{(\text{m}^2)(\text{°K})}$$

$$\text{Thermal conductance} = K = \frac{(\text{Btu})(\text{inch})}{(\text{hr})(\text{ft}^2)(\text{°F})} = \frac{\text{W}}{(\text{m})(\text{°K})} = \frac{(\text{Btu})}{(\text{hr})(\text{ft})(\text{°F})}$$

$$\text{Thermal conductance} = R = \frac{(\text{ft}^2)(\text{hr})(\text{°F})}{\text{Btu}} = \frac{(\text{m}^2)(\text{°K})}{\text{W}}$$

INSTALLATION PROCEDURE (Use a Listed Direct or Positive Connect)(See Page 6).

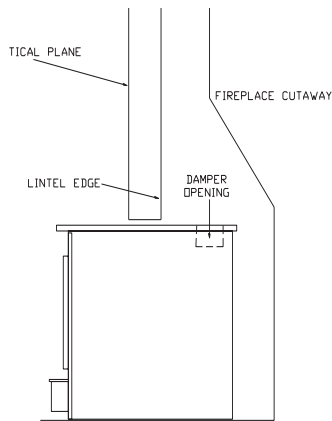

FIGURE 5 POSITIONING

POSITIONING THE HEATER

NOTE: If the three suggested installations have been chosen, certain steps must be followed when installing heater into a masonry fireplace.

When positioning heater, the following conditions **MUST** be met! (See Figure 5).

1. The front of damper opening must be positioned **BEHIND** back edge of the lintel to ensure proper draft. (See Figure 5).
2. Center heater in fireplace opening.

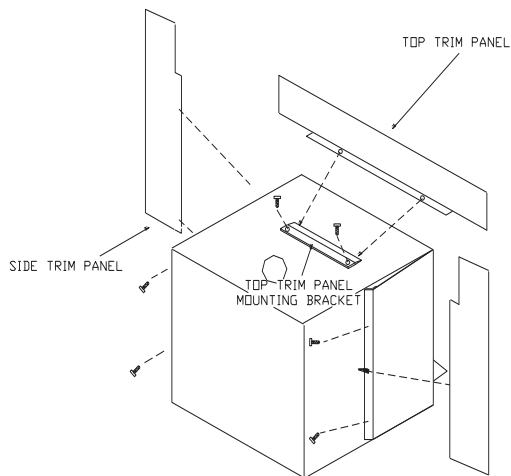

FIGURE 6 MOUNTING TRIM PANELS

MOUNTING THE TRIM PANELS

After unit is positioned as shown in (Figure 8), mark mounting position of trim panels as follows:

1. Place side trim panels in place, flat against the face of the fireplace. Mark down front edge of trim panel with a pencil to make a vertical reference line. (See Figure 6).
2. Place top (long) trim panel in place on top of unit. The panel should be flat against the outside face of fireplace and standing vertically. Mark along lower edge of trim panel with a pencil to make a reference line for mounting.

3. Slide unit out of the fireplace far enough to work behind trim panel reference lines.
4. Mount side trim panels. (See Figure 6).
 - a. Position trim panel on reference line.
 - b. Drill mounting holes in center of trim panels mounting brackets to allow for adjustment in and out if necessary.
 - c. Mount trim panel using self-tapping screws provided.
5. Place top panel back on reference mark. Take top trim panel mounting bracket supplied with unit. Position bracket so it overlaps rear lip of top trim panel. Drill mounting holes in top of stove using holes in bracket as guide. Tighten down screws.
6. Now, follow installation procedures in the listed direct connect or positive connect kit you are using and install heater connect kit in the fireplace.
7. Slide unit back into fireplace. Check to be sure that trim panels are properly positioned and lie flat against front of fireplace. If one or more of the panels is out of position, slide unit out and reset by loosening mounting screws and repositioning in slot.
8. Reinstall top trim panel by sliding rear lip of top trim panel underneath front lip of mounting bracket already secured to top of unit.

NOTE: Mount top trim panel so that it sits in front of top of side trim panels.
9. Obtain brass trim kit provided with unit and slip over top and sides of trim panels. (Top ends of brass may need to be trimmed to fit).

10. If direct connect or positive connect kit is not used, follow instructions in *mounting trim panels, steps 1-4c* on page 10.
11. Mount top trim panel by drilling mounting holes in center of trim panel mounting brackets, with top end side of top panel overlapping side panel.
12. Using insulation provided, peel and stick to back of panels overlapping fireplace dimensions by 1" on each side and top. (See Page 8, Figure 6).
13. Next using high heat silicone or furnace cement run heavy bead of caulking around where panels meet stove. (See Figure 7).
14. Slide the unit back into fireplace. Check to be sure that trim panels (and brass) are properly positioned and lie flat against front of fireplace. If panels are out of position, slide unit out and reset by loosening mounting screws and repositioning in the slot. Using the bar, lift stove in front. Place insulation across front and the surface of hearth or bottom of fireplace, to make complete seal.
15. To check seal of panels, use candle flame and go around entire area sealed by silicone and insulation. If flame leans toward inside of fireplace, add additional insulation. This ensures an airtight seal.

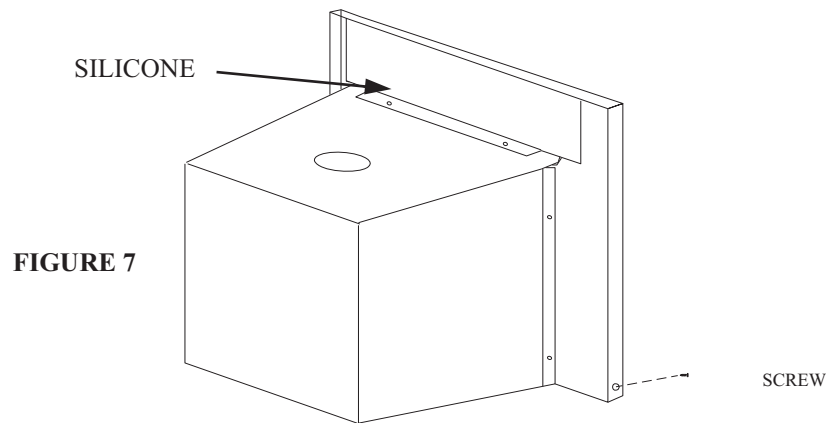

POSSIBLE TOOLS NEEDED FOR INSTALLATION

If you decide to install your own stove, there are several hand tools you may need to do the job. If you do not already have them, they are readily available at most hardware stores.

Caulking gun

Large adjustable wrench (may not be needed)

Drop cloths or newspapers

Vacuum cleaner or whisk broom

Flashlight

1 tube of RTV silicone (Code 103 or 106, or high temperature rubber cement rated between 450° F- 600° F)

7/32" drill bit and drill

Socket/Ratchet Set

INSTALLATION PREPARATION

1. Relocate furniture and other materials away from front of fireplace to allow free access to fireplace.
2. Cover hearth and adjacent floor areas with a drop cloths to protect from soiling or marring surface.
3. Remove existing fireplace damper plate.
4. Thoroughly clean fireplace of ashes and soot.
5. Check chimney and smoke chamber for excessive buildup of creosote or soot. Also, check for obstructions, such as birds nests. If chimney is excessively dirty, clean it or have someone clean it professionally **BEFORE** installing or using room heater.
6. If fireplace has an ash dump or outside air provision, these must be sealed off with metal or tightly packed non-combustible insulation to prevent cold air from entering fireplace chamber.

MASONRY INSERT INSTALLATION OPTIONS

This unit (appliance) may be installed into an all masonry fireplace, built in accordance with the Uniform Building Code and the National Fire Protection Association (*NFPA 211*).

NOTE: Check with local building officials for any permits required for installation of this unit and notify your insurance company before proceeding with installation

In some cases, such as improperly drawing fireplaces, oversize flue liners are to meet codes in certain areas it is recommended that one of the following procedures be followed:

- A. A **Chimney Connector** can be installed from the appliance flue exit through the damper and an air-tight face seal. (See option (A) Page 9).
- B. A listed **Direct Connect** can be installed from the appliance flue exit through the damper into the first section of the flue liner with air-tight seal. (See option (B) Page 9).
- C. A **Positive Connect** can be installed from the appliance flue exit continuing up through the entire chimney and exiting at the top of the chimney. (See option (C) Page 9).

NOTE: If mounting trim panels, See Page 8-9.

FINAL CHECK

1. Recheck specified clearances.
2. Remove all foreign material from firebox area.
3. Open the primary air draft.
4. Plug power cord into a 115V AC outlet if optional motor is being used. Do not run cord under unit or in high traffic areas.
5. Place crumpled pieces of newspaper in the stove. Light it and close door. Ensure that the stove draws properly through primary draft.
6. Check for smoke leaks around door.
7. Open door and check for smoke escaping from front of stove. Smoking usually indicates a defective or poorly positioned chimney. Some chimneys with a marginal draft can be preheated by lighting newspaper and holding it near open damper with a poker or fire tong. Once the chimney heats up, a proper draft can usually be obtained.

If a thorough review of the Troubleshooting Guide in the manual does not reveal the problem, contact your dealer for assistance.

SAFETY NOTICE: ⚠️

If this appliance is not properly installed, a house fire may result. For your safety, follow the installation directions. Contact local building or fire officials about restrictions and installation inspection requirements in your area.

OPTION (A)

SEAL TRIM PANELS AND UNDER FRONT OF STOVE UNIT WITH INSULATION OR HIGH TEMPERATURE CAULK

STARTER PIPE

AIRTIGHT INSULATED CLEAN-OUT

REMOVE DAMPER OR WIRE IT OPEN

NOTE: New Buck Corporation grants no warranty, implied or stated, for the installation or maintenance of your appliance, and assumes no responsibility of any consequential damage

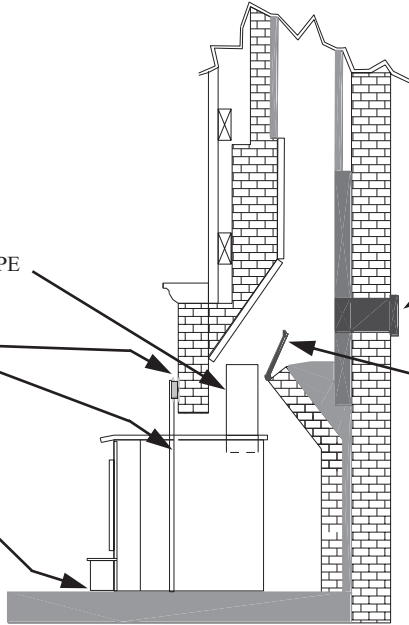

OPTION (B)

NOTE: Follow installation instruction with Direct Connection Kit. (Kit sold separately)

SEAL TRIM PANELS WITH INSULATION OR HIGH TEMPERATURE CAULK

STAINLESS STEEL CHIMNEY CONNECTOR MUST EXTEND 1' PAST THE BLOCK-OFF PLATE OR TO THE FLUE LINER

AIRTIGHT INSULATED CLEAN-OUT
REMOVE DAMPER OR WIRE IT OPEN

BLOCK-OFF PLATE OR DAMPER ADAPTER

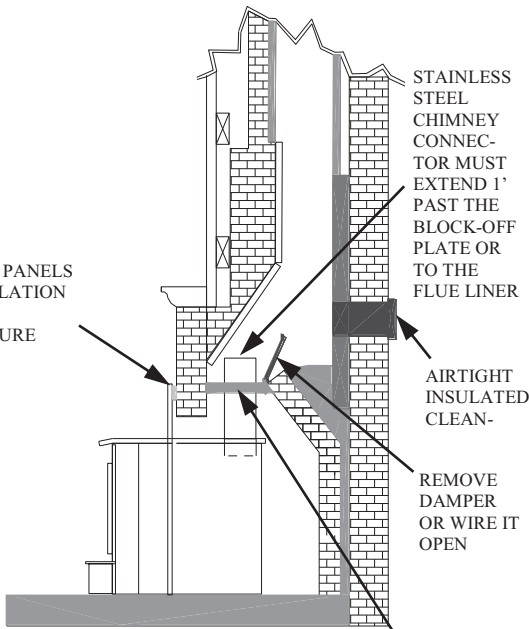

OPTION (C)

NOTE: Follow installation instruction with Positive Connection Kit. (Kit sold separately)

INSTALL A NON-COMBUSTIBLE COVER PLATE TO PREVENT WATER FROM ENTERING THE CHIMNEY

CAP PREVENTS WATER FROM ENTERING)

FLUE LINER

THE LINER MUST BE STAINLESS STEEL CONNECTOR OR FLEXIBLE VENT. FOLLOW THE LINER MANUFACTURER'S INSTRUCTIONS FOR INSTALLATION AND SUPPORT.

AIRTIGHT INSULATED CLEAN-OUT

TRIM PANELS

REMOVE DAMPER OR WIRE IT OPEN

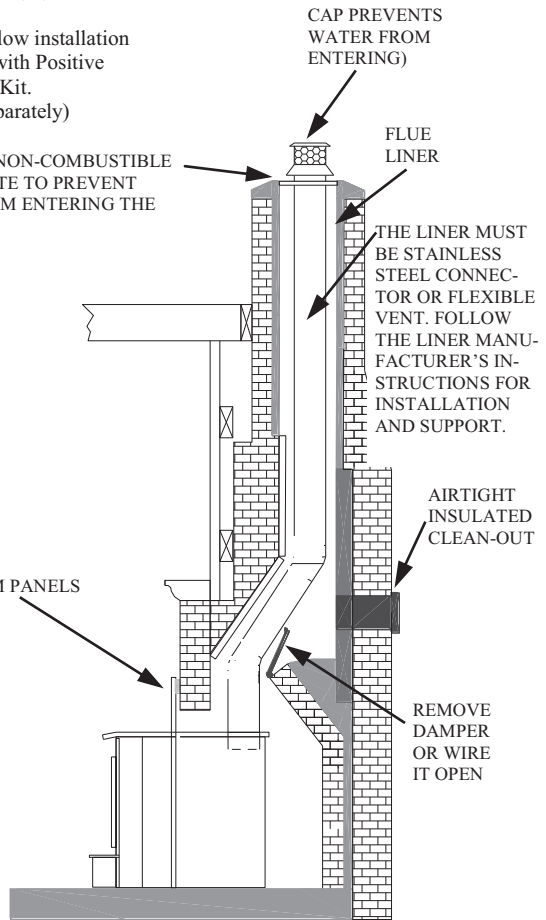

CAUTION

THE UNIT IS PAINTED WITH A SPECIALLY FORMULATED HIGH TEMPERATURE PAINT THAT CURES DURING THE FIRST TWO OR THREE FIRINGS. YOU MAY NOTICE A SLIGHT SMOKING EFFECT AND AN ODOR OF BURNING PAINT WHEN YOU BUILD THE FIRST FIRES. THIS IS NORMAL AND IS NOT A CAUSE FOR ALARM. IN SOME CASES, THESE FUMES WILL ACTIVATE A SMOKE ALARM. OPENING A WINDOW NEAR THE UNIT WILL ALLOW THESE FUMES TO ESCAPE. DO NOT BUILD A LARGE, ROARING FIRE UNTIL THIS CURING IS COMPLETE OR THE HEATER FINISH MAY BE DAMAGED.

The connector and/or chimney should be inspected at least once a month during the heating season to determine if a creosote buildup has occurred.

CAUTION

NEVER USE GASOLINE, GASOLINE-TYPE LANTERN FUEL, KEROSENE, CHARCOAL LIGHTER FLUID OR SIMILAR LIQUIDS TO START OR "FRESHEN UP" A FIRE IN THE HEATER. KEEP ALL SUCH LIQUIDS WELL AWAY FROM THE STOVE WHEN IT IS IN USE. ALL FLUIDS OF THIS TYPE GIVE OFF VOLATILE FUMES AND CAN AND WILL EXPLODE! DON'T TAKE A CHANCE WITH THE SAFETY OF YOUR HOME AND FAMILY.

SECTION III

PRE-FAB INSERT INSTALLATION

The Model 21 has been tested with the following:

Heatilator	Security
Tempco	Preway
Marco	FMI
Woodside	Majestic

NOTE: The Model 21 may be installed in any of the pre-fabricated fireplaces listed above if they are big enough to accept heater.

NOTE: A FULL CHIMNEY LINER IS REQUIRED IN A ZERO CLEARANCE OR PRE - FABRICATED FIREPLACE.

NOTE: The ash lip, smoke baffle and smoke shelf may be removed if necessary to provide room for these models. Any other alteration to unit will void ALL NEW BUCK CORPORATION, responsibility and liability. The warning label below must be attached to the pre- fabricated fireplace before unit is installed.

Except for the “notes” above, please follow the instructions for Masonry Insert Installation including Minimum Clearances for stove and floor protector in Section II.

NOTE: When installing trim panels DO NOT COVER ANY EXITING LOUVERS OR AIR OPENING IN PRE-FABRICATED FIREPLACE .

WARNING: This fireplace must be restored to its original condition for safe use, if the fireplace insert is removed.

SECTION IV

RESIDENTIAL FREESTANDING INSTALLATION

TOOLS FOR INSTALLATION

Drop cloth, 3/32" Metal drill bit, 5/16" magnetic socket chuck adapter, 5/16" wrench (box or socket) or adjustable wrench, Jigsaw with masonry, metal and wood blades

WARNING: DO NOT INSTALL IN A SLEEPING ROOM

PREPARING THE STOVE FOR INSTALLATION

1. Remove the protective plastic wrapping from unit, inspect unit for any obvious physical damage.
2. Plug power cord into a 115V AC outlet to test motor and fan when optional motor is being used. Do not run cord under unit or in high traffic areas.
3. Check primary air draft control to ensure that it slides freely.(See Figure 11).
4. Remove any items from within firebox. Spread a dropcloth on floor behind heater. Next, tilt heater so that back is on drop cloth.
5. **(Leg Kit):** If legs are to be used, obtain four legs, attach legs to holes in bottom of unit with bolts and washers supplied with the leg kit. (See Figure 11).
6. **(Pedestal Kit):** If pedestal kit is being used an outside air is required, see *Out Side Air Installation* below. Open freestanding kit and obtain stand. Place stand against bottom of heater (angle side to heater). Center stand front to back and also center stand left and right. Mark screw locations on bottom of stove through outer holes of stand mounting angles. Set stand aside and drill four 7/32" holes in heater bottom. Before attaching heater to stand, take a large flat screwdriver or pliers and remove the 2" x 2" knockout on bottom of unit. (See Figure 12). Then mount stand to bottom of heater with screws provided. (See Figure 12).
7. Obtain four (4) 3/16" self-tapping screws and secure stand to heater.
8. Reposition heater to the upright position.

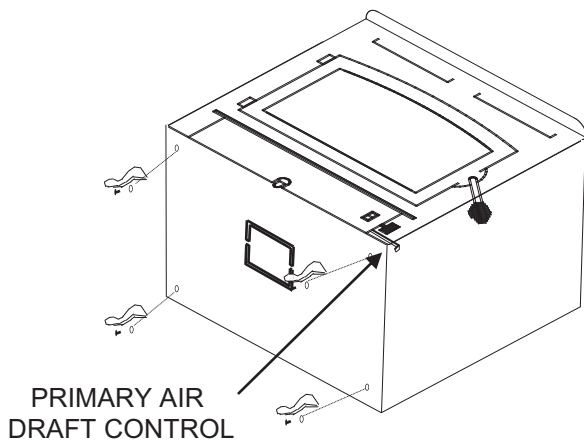

Figure 11

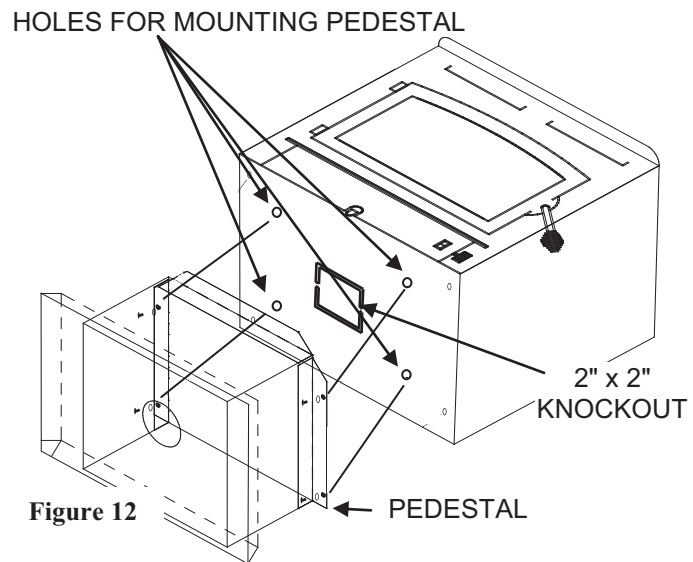

Figure 12

Out Side Air Installation

CAUTION

THE STRUCTURAL INTEGRITY OF THE MOBILE HOME FLOOR MUST BE MAINTAINED. (MOVE OPENING AND/OR REPOSITION HEATER LOCATION IF NECESSARY).

1. Select an installation location that gives the best airflow from the front of heater to remainder of home.
2. Place protective floor pad in position. For minim floor protection (See Page 16).

3. Place unit on pad making sure minimum clearance specifications are met.
4. Lightly mark with a pencil the location of pedestal on protective pad.
5. Next, remove the four (4) screws holding heater to stand. Position heater out of the way of installation area.
6. Check that pedestal stand is still aligned with marks on the protective pad, now mark outside air opening in bottom of pedestal stand on to the pad.
7. Mark center line of outside air opening. Set stand aside for now.
8. Cut a 4 1/4" diameter hole in pad and continue through floor.
CAUTION. The structural integrity of mobile home floor must be maintained.
(Move opening and/or reposition heater location if necessary).
9. Now, reposition pedestal stand on pad being sure to line stand up with reference marks on pad.
10. Using an electric drill and 3/8" masonry bit, drill four (4) holes in the protective pad using holes in the bottom of the pedestal stand as a guide. Be careful to drill only through pad and not into floor. Change the bit to a 1/4" metal bit and drill through floor.
11. Using four (4) 3/8" x 1-1/2" lag bolts, secure pedestal stand and pad to floor of mobile home.

CAUTION

IF A THICK FLOOR PROTECTOR IS USED, YOU MAY HAVE TO USE LONGER LAG BOLTS.

12. Obtain outside air duct from the box in pedestal kit marked FA P21B.
13. Slip duct down through the 4-1/4" hole until the face of outside air duct with screen wire, contacts bottom of pedestal.
14. Secure outside air duct to inside bottom of pedestal using four (4) #10x1 screws provided. (See Figure 13).
15. Set heater back onto stand and resecure using screws.
16. NOTE: If home is underpinned, you must duct through underpin as shown. (See Figure 14).

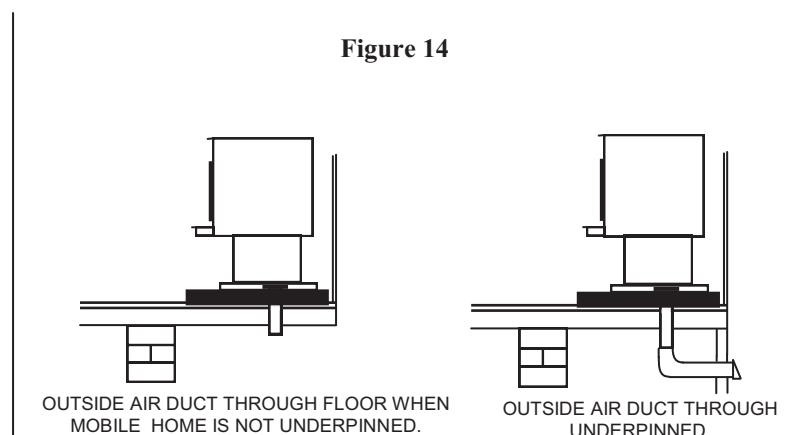
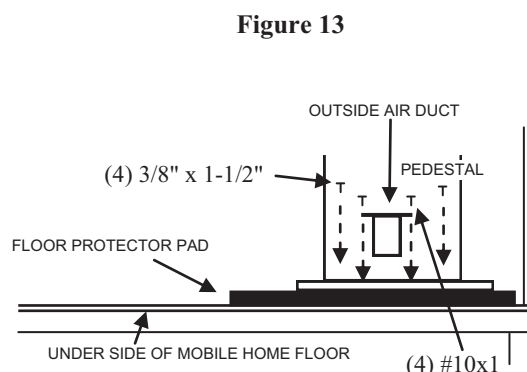

Floor Protection:

Floor protection must be 3/8" minimum thickness non-combustible material or equivalent.

How to use alternate materials and how to calculate equivalent thickness

An easy means of determining if a proposed alternate floor protector meets requirements listed in the appliance manual is to follow this procedure:

1. Convert specification to R-value:
 - R-value is given—no conversion is needed.
 - K-factor is given with a required thickness (T) in inches:
 - C-factor is given: $R=1/C$
2. Determine the R-value of the proposed alternate floor protector.
 - Use the formula in step (1) to convert values not expressed as "R"
 - For multiple layers, add R-values of each layer to determine the overall R-value.
3. If the overall R-value of the system is greater than the R-value of the specified floor protector, the alternate is acceptable.

Example:

The specified floor protector should be 3/4" thick material with a K-factor of 0.84.

The proposed alternate is 4" brick with a C-factor of 1.25 over 1/8" mineral board with a K-factor of 0.29.

Step (a): Use formula above to convert specification to R-value. $R= 1/K \times T = 1/0.84 \times .75 = 0.893$

Step (b): Calculate R of proposed system. 4" brick of $C=1.25$, therefore $R_{brick} = 1/C = 1/1.25 = 0.80$ 1/8" mineral board of $K = 0.29$, therefore $R_{min.bd.} = 1/0.29 \times 0.125 = 0.431$

Step (c): Compare proposed system R of 1.231 to specified R of 0.893. Since proposed system R is greater than required, the system is acceptable.

Definitions:

$$\text{Thermal conductance} = C = \frac{\text{Btu}}{(\text{hr})(\text{ft}^2)(\text{°F})} = \frac{W}{(\text{m}^2)(\text{°K})}$$

$$\text{Thermal conductance} = K = \frac{(\text{Btu})(\text{inch})}{(\text{hr})(\text{ft}^2)(\text{°F})} = \frac{W}{(\text{m})(\text{°K})} = \frac{(\text{Btu})}{(\text{hr})(\text{ft})(\text{°F})}$$

$$\text{Thermal conductance} = R = \frac{(\text{ft}^2)(\text{hr})(\text{°F})}{\text{Btu}} = \frac{(\text{m}^2)(\text{°K})}{W}$$

Install in accordance with 24 CFR, Part 3280 (HUD).

Chimney

This model is designed for connection to any listed 2100° UL103 HT chimneys and parts. Follow chimney manufacturer's instructions carefully.

This room heater must be converted to (1) a chimney complying with the requirements for Type HT chimneys in the Standard for chimneys, Factory-Built, Residential, Type and Building Heating Appliance, UL 103 or (2) a code approved masonry chimney with a flue liner.

PREPARING THE ROOM HEATER LOCATION

1. Select an installation location that will give the best airflow from the front of the heater to the remainder of the home.
2. Place the protective floor pad in position.
3. Place unit on pad making sure minimum clearance specifications are met.
4. If connecting to an existing masonry flue, first ensure that flue conforms to the **NFPA-211** Code and/or consult your local code for proper procedures.

NOTE: This model is designed for connection to: any Listed 2100° UL 103 HT. TYP chimney also any Listed UL DVL Close Clearance Pipe or Single wall minimum 24 ga. Blued or Black Pipe. Follow pipe manufacturer's instructions carefully.

CHIMNEY

This room heater must be converted to (1) a chimney complying with requirements for Type HT chimneys in the Standard for Chimneys, Factory-Built, Residential, Type and Building Heating Appliance, UL 103, or (2) a code approved masonry chimney with flue liner.



CAUTION: Certain installation types require the use of certain chimney types. Please follow these instructions exactly.

HOW TO LOCATE CHIMNEY EXIT AND INSTALL

Residential Installation

A. Vertical Exit using (6" Single Wall minimum 24 ga. blued or black pipe and any Listed 2100° UL 103 HT. chimney).

Without optional close clearance shield and pipe shield.

NOTE: For minimum clearances (See Page 18, Figure 15).

1. Suspend a plumb bob from ceiling above unit so that weight is hanging in the center of flue exit. (A small weight on a string will serve as a plumb bob). Mark ceiling where string is suspended to locate center of chimney.
2. After locating center of hole, install ceiling support box, chimney or chimney connector, flashing, and rain cap, per chimney manufacturer's instructions and local building codes for installation through combustible walls or ceilings.
3. Now connect stove and ceiling support box using 6" Single Wall minimum 24 ga. blued or black pipe (**DO NOT USE GALVANIZED PIPE**). Connect each section so crimped end faces downward and secure each section to each other using at least three (3) sheet metal screws or rivets. Single wall pipe is to be connected with (3) sheet metal screws or rivets to connector collar on heater. (See Page 18, Figure 16).
4. **NOTE:** If your local code requires outside air for residential installation, refer to pages 14-15 for outside air installation.

**A. Vertical exit using (6" Single Wall minimum 24ga. blued or black pipe and any listed 2100° UL 103 HT. TYPE Chimney)
Without optional close clearance shield and pipe shield
Model 21 minimum clearance to combustibles**

Figure 15

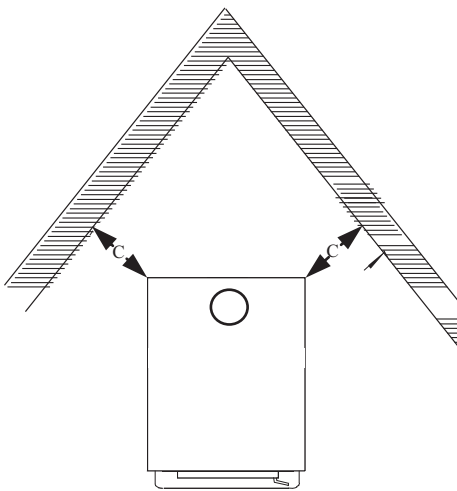
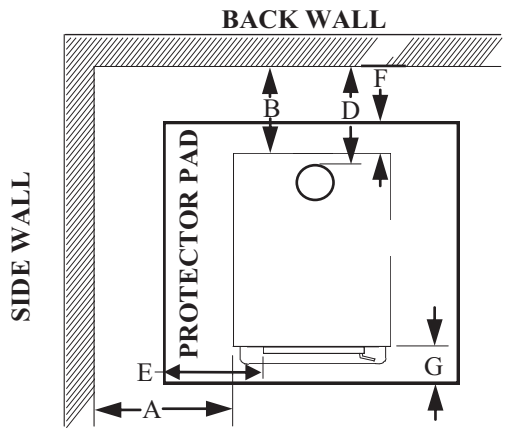

A B C D E F G

MODEL 21 25" 13" 13" 15.5" 8" 6" 16"

Figure 16

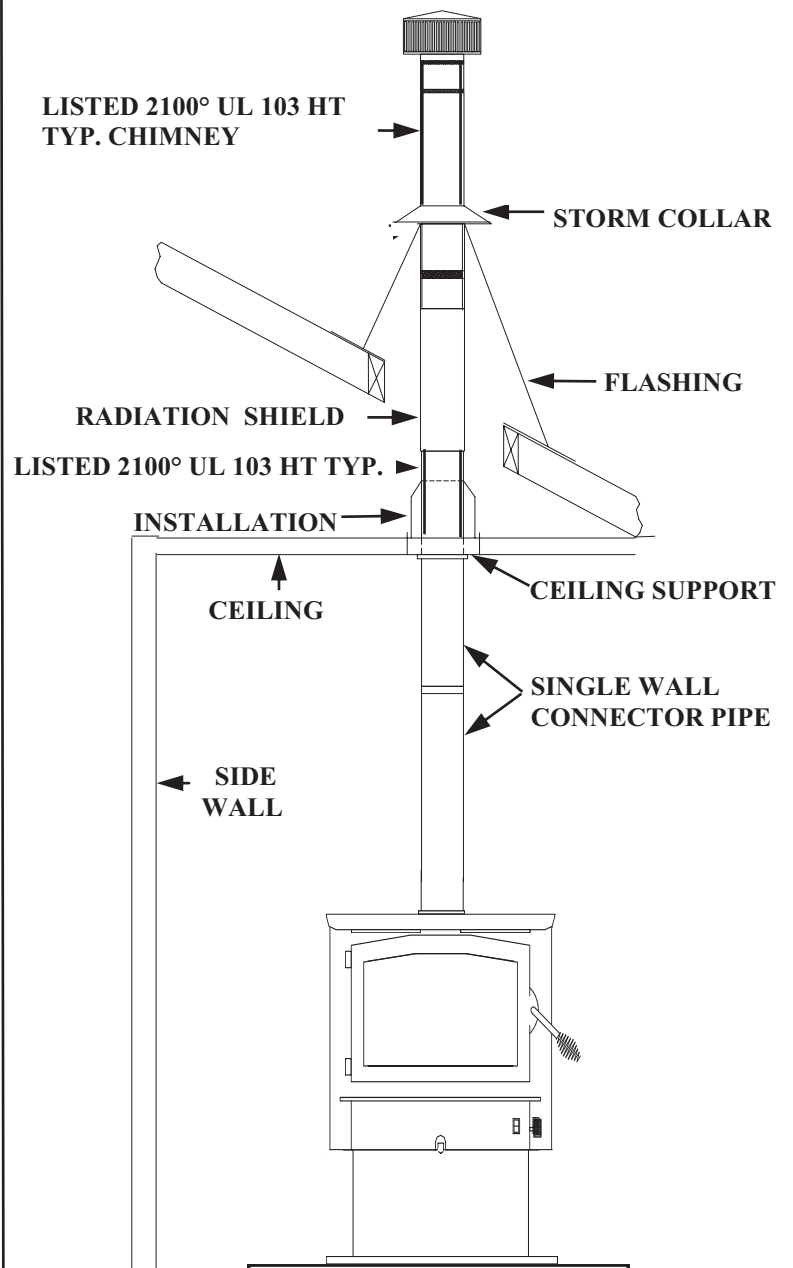

NOTE: All clearances are to combustibles without close clearance shields and pipe shield, using 6" Single Wall minimum 24ga. blued or black pipe and minimum floor protector. The clearances above may be reduced. Follow NFPA-211 codes if available or follow instructions on (Pages 21, 22 or Pages 25, 26).

HOW TO LOCATE CHIMNEY EXIT AND INSTALL

Residential Installation

- B. Vertical Wall Exit using (6" Single Wall minimum 24ga. blued or black pipe with elbow and any Listed 2100° UL HT chimney and Listed 2100° UL HT. T-Box assembly). Without optional close clearance shields and pipe shield.**

NOTE: For minimum clearances (See Page 20, Figure 17).

1. Mark the plumb line on wall directly behind center of heater.
(See Page 20, Figure 18).
NOTE: When using 6" Single Wall minimum 24ga. blued or black pipe, maintain 18" minimum clearances" between pipe and ceiling.
2. Place vertical portion of heater pipe and elbow in position and project a point onto plumb line level with center of elbow.
3. Measure up so there will be at least 1/4" rise per foot of horizontal connector pipe, maintaining clearances to ceiling as noted in (Page 20, Figure 18). This will give you center of hole for the chimney penetration.
4. After locating center of penetration, install tee-box and chimney, per chimney manufacturer's specifications.
5. Connect chimney collar to tee-box using 6" Single Wall minimum 24ga. blued or black pipe. (DO NOT USE GALVANIZED PIPE). Connect each section so crimped end faces downward and secure each section to each other using three (3) sheet metal screws or rivets. Single wall pipe is to be connected with three (3) sheet metal screws rivets to connector collar on heater. (See Page 20, Figure 18).
6. **NOTE: If your local code requires outside air for residential installation, refer to pages 14-15 for outside air installation.**

**B. Vertical wall exit using (6" Single Wall minimum 24ga. blued or black pipe with elbow and any listed 2100° UL 103 HT. TYPE Chimney and Listed 2100° UL HT. T-Box assembly).
Without optional close clearance shield and pipe shield.
Model 21 minimum clearance to combustibles.**

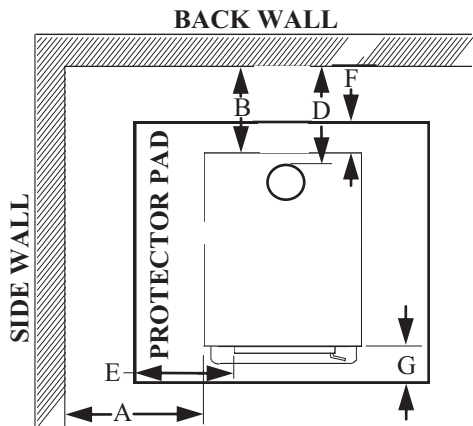
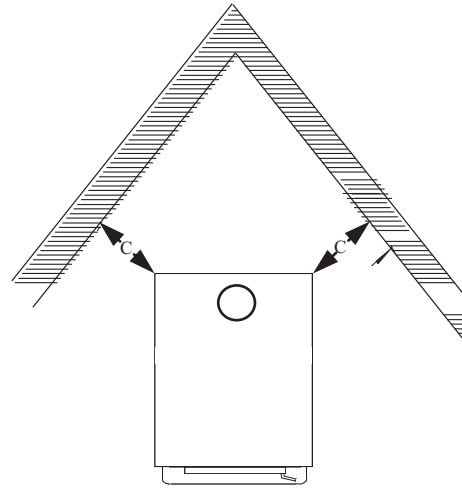

Figure 17



	A	B	C	D	E	F	G
MODEL 21	25"	13"	13"	15.5"	8"	6"	16"

NOTE: All clearances are to combustibles without close clearance shields and pipe shield, 6" Single Wall minimum 24ga. blued or black pipe with elbow and minimum floor protector. Clearances above may be reduced. Follow NFPA-211 codes if available or follow instructions on (Pages 23,24 or Pages 27, 28).

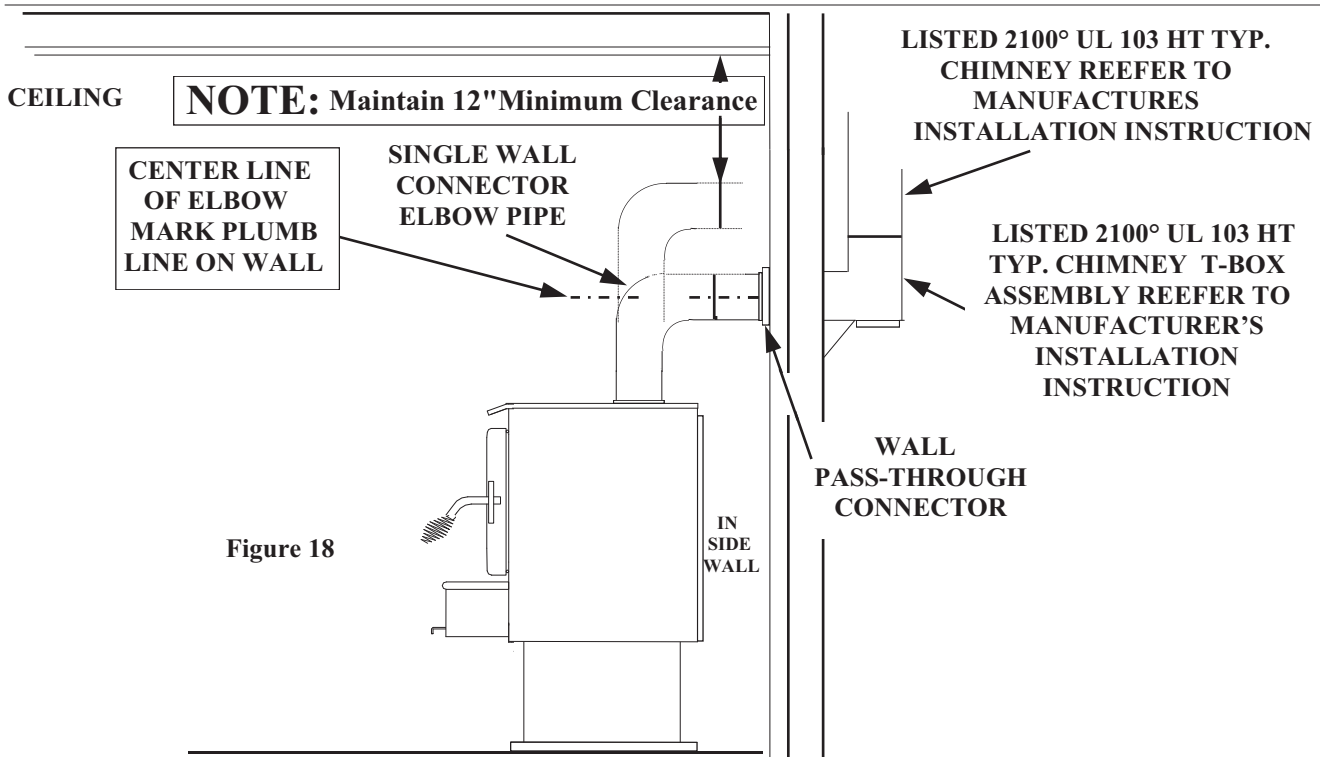

Figure 18

HOW TO LOCATE CHIMNEY EXIT AND INSTALL

Residential and Mobile Home Installation

C. Vertical Exit using (6" DVL Close Clearance pipe and any Listed 2100° UL 103 HT chimney).

Without close clearance shield and pipe shield.

NOTE: For minimum clearances (See Page 22, Figure 19).

1. Suspend a plumb bob from ceiling above unit so that weight is hanging in the center of flue exit. (A small weight on a string will serve as a plumb bob). Mark ceiling where string is suspended to locate the center of chimney. (See Page 23, Figure 20).
2. After locating center of hole, install ceiling support box, chimney or chimney connector, flashing and rain cap, per chimney manufacturer's instructions and local building codes for installation through combustible walls or ceilings.
3. Now connect stove and ceiling support box using DVL close clearance pipe. Connect each section per manufacturer's instructions. Secure each section to each other using minimum (3) sheet metal screws or rivets. DVL close clearance is to be connected with (3) sheet metal screws or rivets to connector collar on heater (See Page 23, Figure 20).
4. NOTE: If your local code requires outside air for residential installation, refer to pages 14-15 for outside air installation.

C. Vertical exit using (6" DVL Close Clearance pipe and any listed 2100° UL 103 HT. TYPE Chimney). Without optional close clearance shield and pipe shield. Model 21 minimum clearance to combustibles.

Figure 19

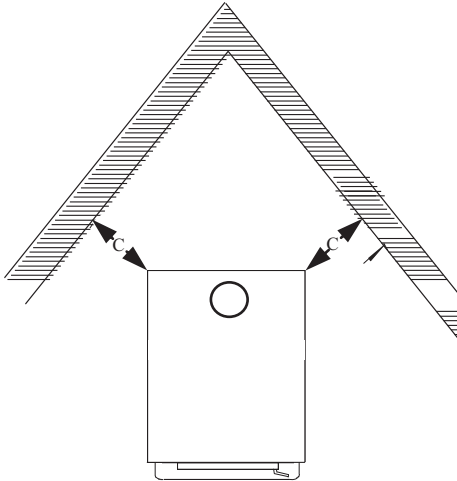
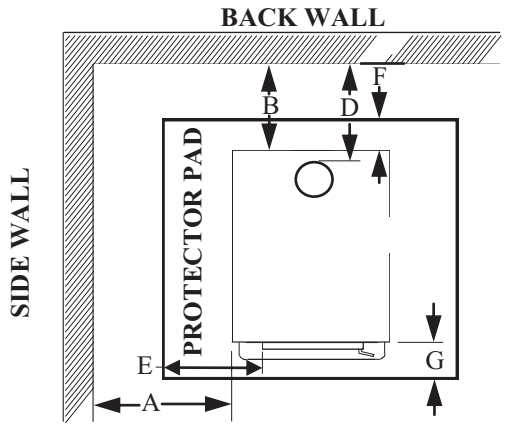

	A	B	C	D	E	F	G
MODEL 21	23"	9"	9"	10.5"	8"	6"	16"

Figure 20

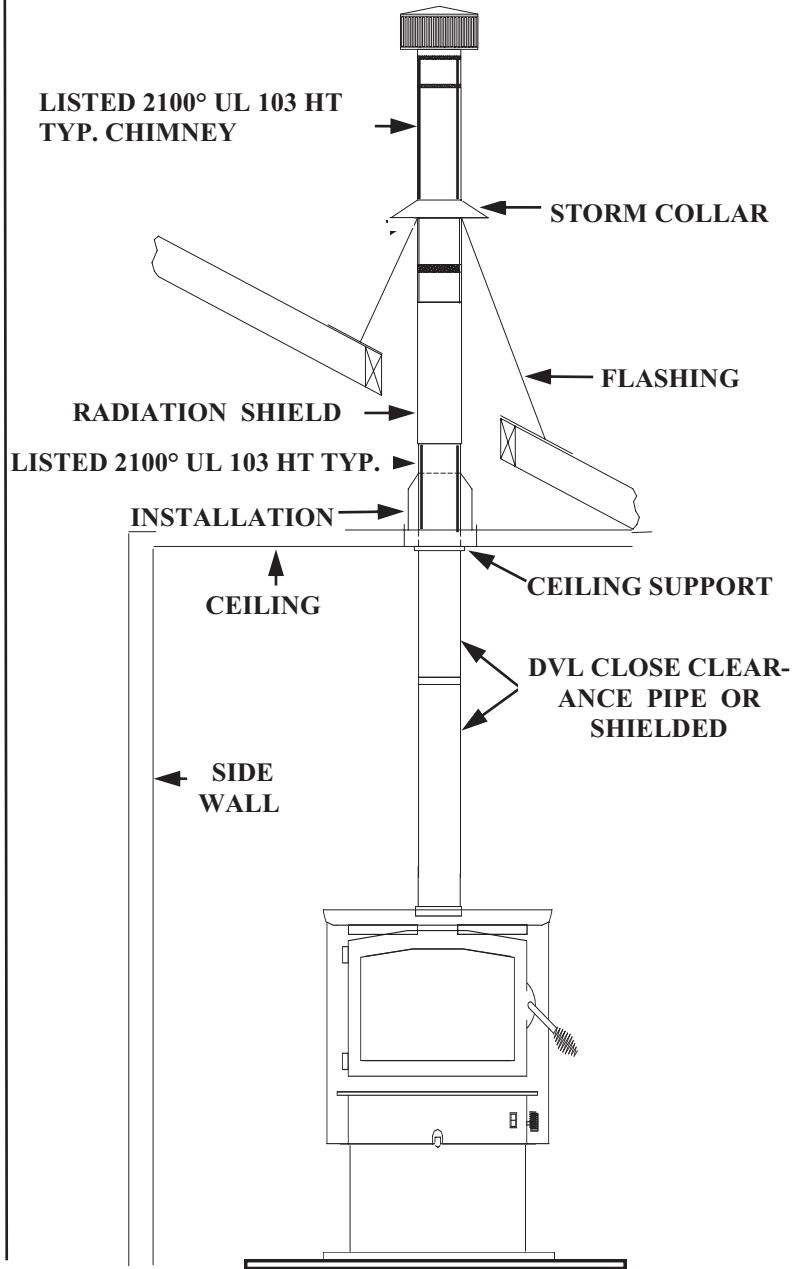

NOTE: All clearances are to combustibles without close clearance shields and pipe shield, using DVL Close Clearance pipe and minimum floor protector. The clearances above may be reduced. Follow NFPA-211 codes if available or follow instructions on (Pages 25 and 26).

HOW TO LOCATE CHIMNEY EXIT AND INSTALL

Residential and Mobile Home Installation

D. Vertical Wall Exit using (6" DVL Close Clearance Pipe and Elbow and any Listed 2100° UL HT chimney and Listed 2100° UL HT T-Box assembly).

Without optional close clearance shield and pipe shield.

NOTE: For minimum clearances (See Page 24, Figure 21).

1. Mark the plumb line on wall directly behind center of heater.
(See Page 24, Figure 22).
NOTE: When using DVL Close Clearance Pipe, maintain manufacturer's minimum clearances between pipe and ceiling.
2. Place vertical portion of heater pipe and elbow in position and project a point onto plumb line level with center of elbow.
3. Measure up so there will be at least 1/4" rise per foot of horizontal connector pipe, maintaining clearances to ceiling as noted in (Page 24, Figure 22). This will give you center of hole for chimney penetration.
4. After locating center of penetration, install the tee-box and chimney, as per chimney manufacturer's specifications.
5. Connect the DVL close clearance pipe to tee-box, per manufacturer's instructions, DVL close clearance pipe is to be connected with (3) sheet metal screws or rivets to connector collar on heater (See Page 24, Figure 22).
6. **NOTE:** If your local code requires outside air for residential installation, refer to pages 13-14 for outside air installation.

D. Vertical wall exit using (6" DVL Close Clearance pipe with elbow) and any listed 2100° UL 103 HT. TYPE Chimney and Listed 2100° UL HT T-Box assembly). Without optional close clearance shield and pipe shield. Model 21 minimum clearance to combustibles.

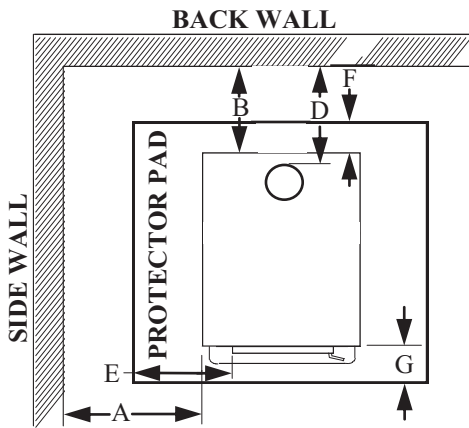
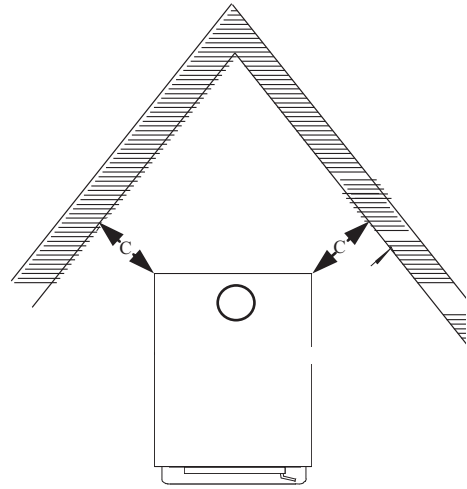

Figure 21



A B C D E F G

MODEL 21 23" 9" 9" 10.5" 8" 6" 16"

NOTE: All clearances are to combustibles without close clearance shields and pipe shield, DVL Close Clearance pipe with elbow and minimum floor protector. The clearances above may be reduced. Follow **NFPA-211** codes if available or follow instructions on (Pages 25 and 26).

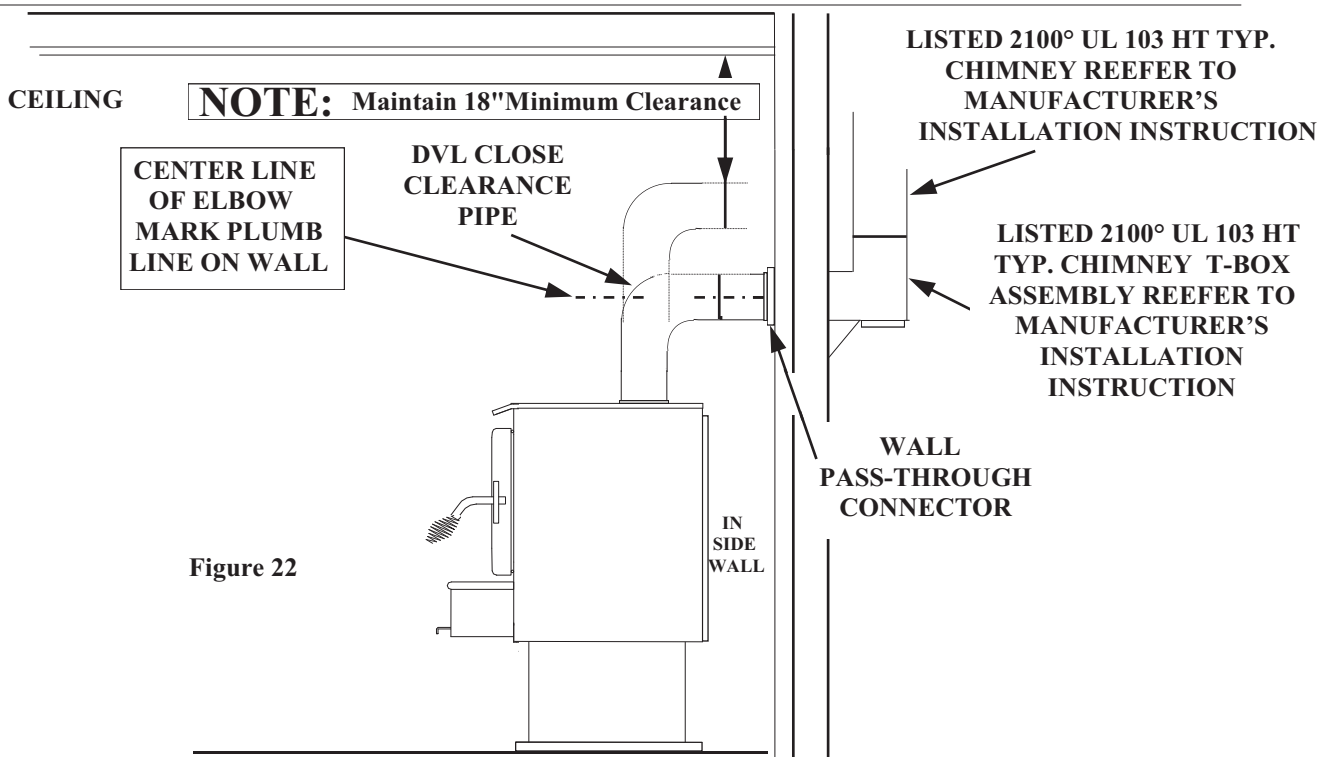

Figure 22

HOW TO LOCATE CHIMNEY EXIT AND INSTALL

Residential and Mobile Home Installation

E. Vertical Exit using (6" DVL Close Clearance pipe and any Listed 2100° UL 103 HT chimney).

With optional close clearance shield and pipe shield. NOTE: For installation of optional close clearance shields and pipe shield (See Page 35).

NOTE: For minimum clearances see page 26, figure 23.

If pedestal kit is being used and outside air is required (See Pages 15-16).

1. Suspend a plumb bob from ceiling above unit so that weight is hanging in the center of flue exit. (A small weight on a string will serve as a plumb bob). Mark ceiling where string is suspended to locate center of chimney. (See Page 26, Figure 24).
2. After locating center of hole, install ceiling support box, chimney or chimney connector, flashing and rain cap, per chimney manufacturer's instructions and local building codes for installation through combustible walls or ceilings.
3. Now connect stove and ceiling support box using DVL close clearance pipe. Connect each section per manufacturer's instructions. Secure each section to each other using minimum (3) sheet metal screws or rivets. DVL close clearance is to be connected with (3) sheet metal screws or rivets to connector collar on heater (See Page 26, Figure 24).
4. NOTE: If your local code requires outside air for residential installation, refer to pages 15-16 for outside air installation.

**E. Vertical exit using (6" DVL Close Clearance pipe and any listed 2100° UL 103 HT. TYPE Chimney).
With optional close clearance shield and pipe shield.
Model 21 minimum clearance to combustibles.**

Figure 23

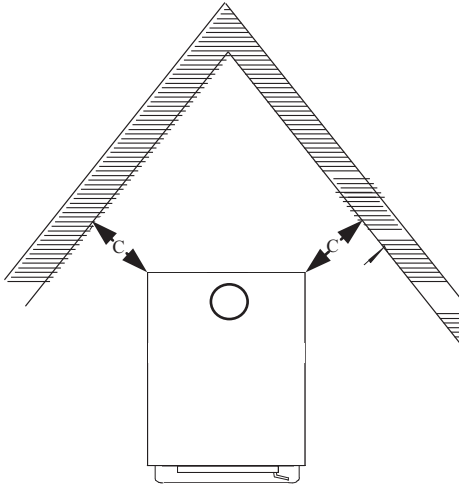
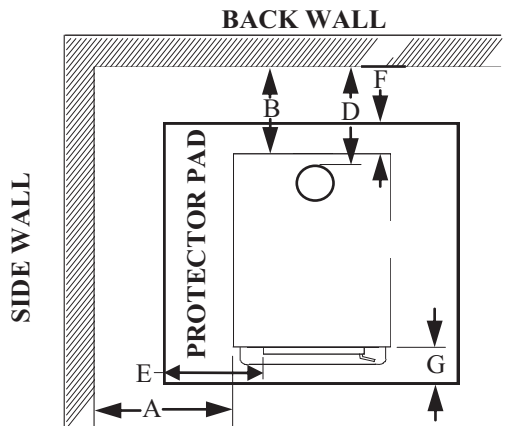

A B C D E F G

MODEL 21 19" 7" 7" 8.5" 8" 6" 16"

Figure 24

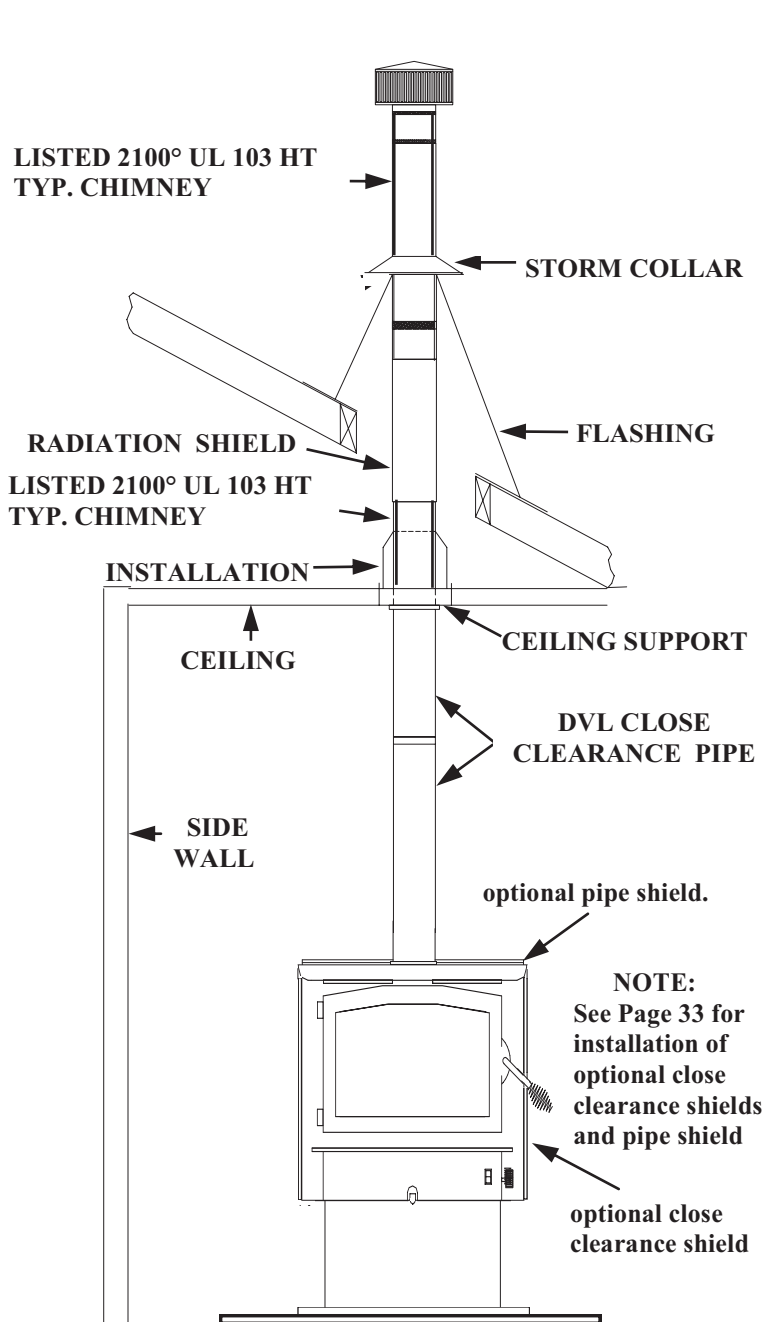

NOTE:
See Page 33 for
installation of
optional close
clearance shields
and pipe shield

optional pipe shield.
optional close
clearance shield

NOTE: All clearances are to combustibles with optional close clearance shields and pipe shield, using DVL Close Clearance pipe and minimum floor protector.

HOW TO LOCATE CHIMNEY EXIT AND INSTALL

Residential and Mobile Home Installation

- F. Vertical Wall Exit using (6" DVL Close Clearance Pipe and Elbow and any Listed 2100° UL HT chimney and Listed 2100° UL HT T-Box assembly).
With optional close clearance shield and pipe shield NOTE: For installation of optional close clearance shields and pipe shield (See Page 35).**

NOTE: For minimum clearances (See Page 28, Figure 25).

If pedestal kit is being used and outside air is required (See Pages 15-16).

1. Mark plumb line on wall directly behind center of heater.
(See Page 28, Figure 26).
NOTE: When using DVL Close Clearance Pipe, maintain manufacturer's minimum clearances between pipe and ceiling.
2. Place vertical portion of heater pipe and elbow in position and project a point onto plumb line level with center of elbow.
3. Measure up so there will be at least 1/4" rise per foot of horizontal connector pipe, maintaining clearances to ceiling as noted in (Page 28, Figure 26). This will give you center of hole for chimney penetration.
4. After locating center of the penetration, install the tee-box and chimney, per chimney manufacturer's specifications.
5. Connect the DVL close clearance pipe to tee-box, per manufacturer's instructions. DVL close clearance pipe is to be connected with (3) sheet metal screws or rivets to connector collar on heater.(See Page 28, Figure 26).
6. NOTE: If your local code requires outside air for residential installation, refer to pages 15-16 for outside air installation.

**F. Vertical wall exit using (6" DVL Close Clearance pipe with elbow and any listed 2100° UL 103 HT. TYPE Chimney and Listed 2100° UL HT T-Box assembly).
With optional close clearance shield and pipe shield.
Model 21 minimum clearance to combustibles.**

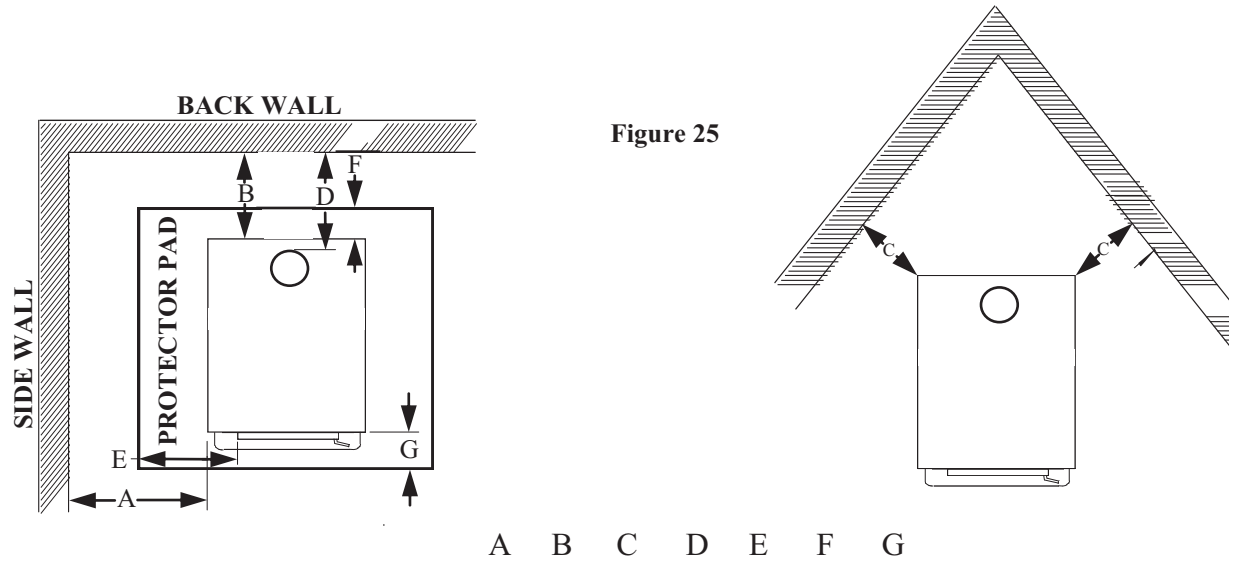

Figure 25

A B C D E F G

MODEL 21 19" 7" 7" 8.5" 8" 6" 16"

NOTE: All clearances are to combustibles with close clearance shields and pipe shield, DVL Close Clearance pipe with elbow and minimum floor protector.

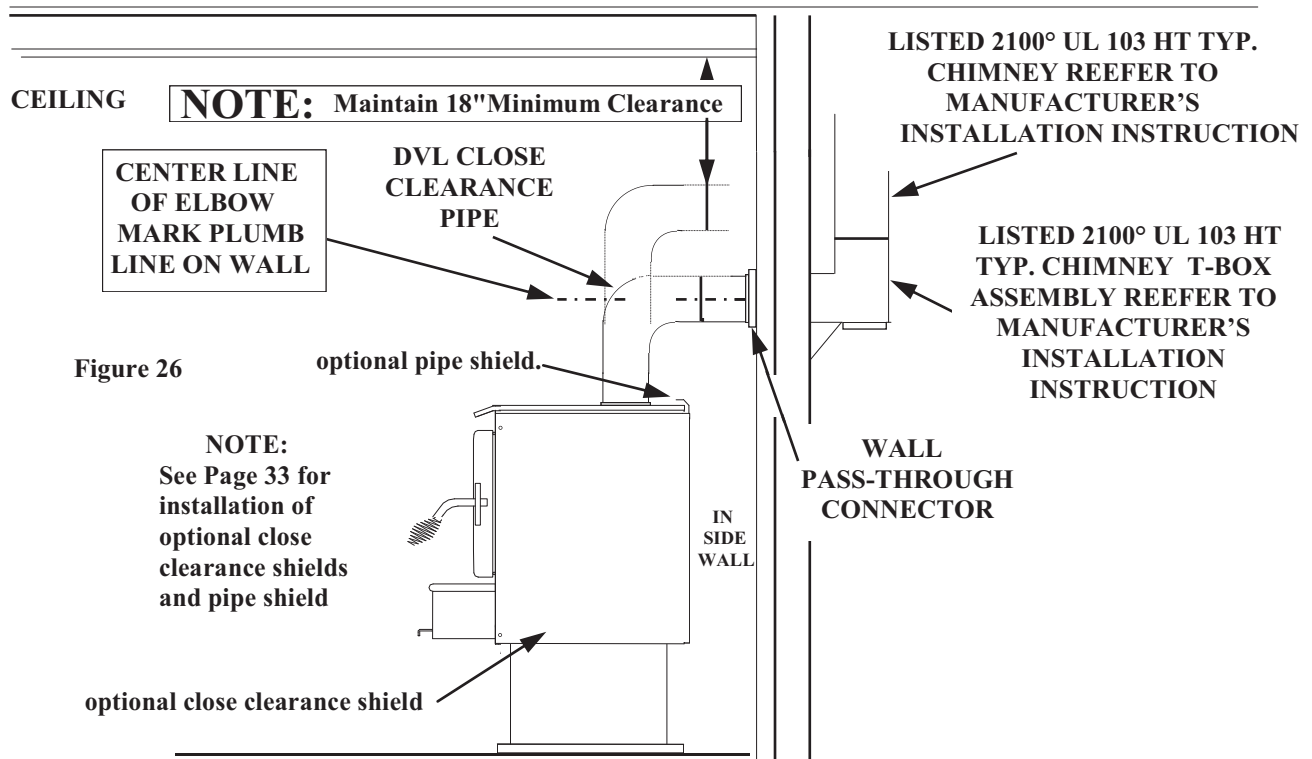

Figure 26

NOTE:
See Page 33 for
installation of
optional close
clearance shields
and pipe shield

Ceiling Exit (Using Close Clearance listed chimney)

1. Suspend a plumb bob from ceiling above unit so that weight is hanging in center of flue exit. (A small weight on a string will serve as a plumb bob). Mark ceiling where string is suspended to locate center of chimney hole.
2. After locating center of hole install ceiling support box, chimney flashing and rain cap. Only use 2100° UL 103 HT chimney and parts listed in this manual, per chimney manufacturer's instruction.

CAUTION

REFER TO CHIMNEY MANUFACTURER'S INSTRUCTIONS FOR ASSEMBLY AND DISASSEMBLY OF CHIMNEY PARTS. BE SURE TO FOLLOW CHIMNEY INSTRUCTIONS FOR PROPER CLEARANCES TO COMBUSTIBLE AND PROPER AIR SPACING REQUIRED.

3. Add additional pipe until both of following are met:
 - (a) Chimney pipe is 3 feet higher than roof at point where it penetrates roof.
 - (b) Chimney pipe height is at least 2 feet higher than any part of roof within 10 feet of chimney.
 (See Figure 27).

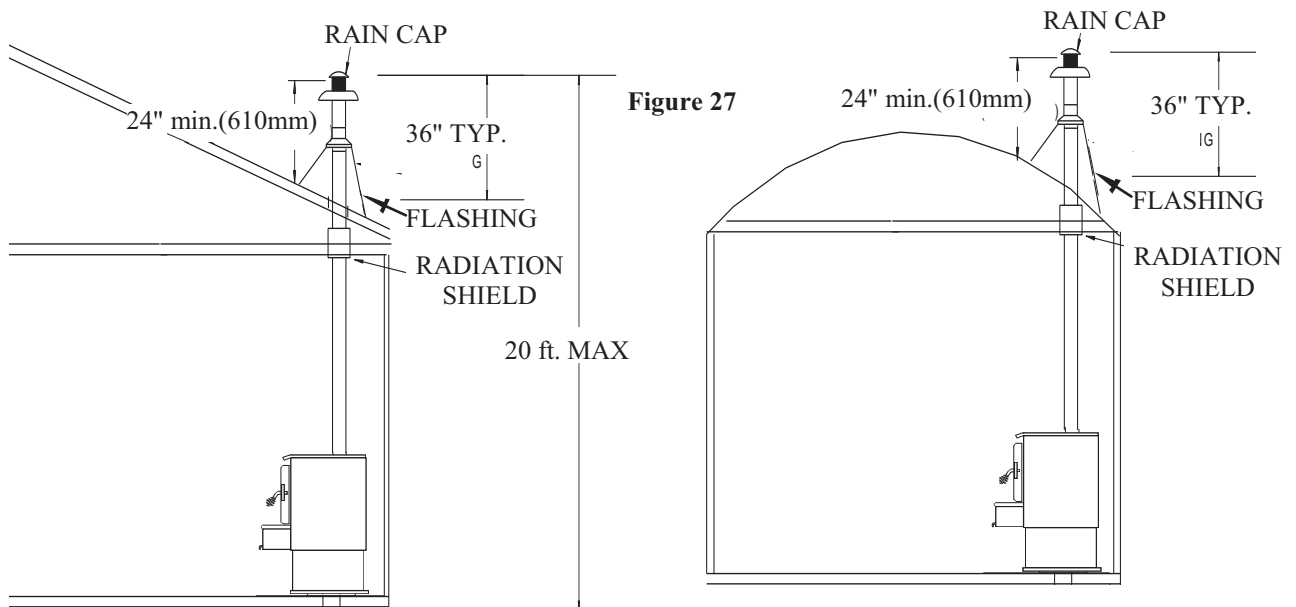

4. Using only double wall chimney connector listed in this manual (See Page 13), connect heater to chimney by following chimney manufacturer's installation instructions exactly. (See Figure 28).

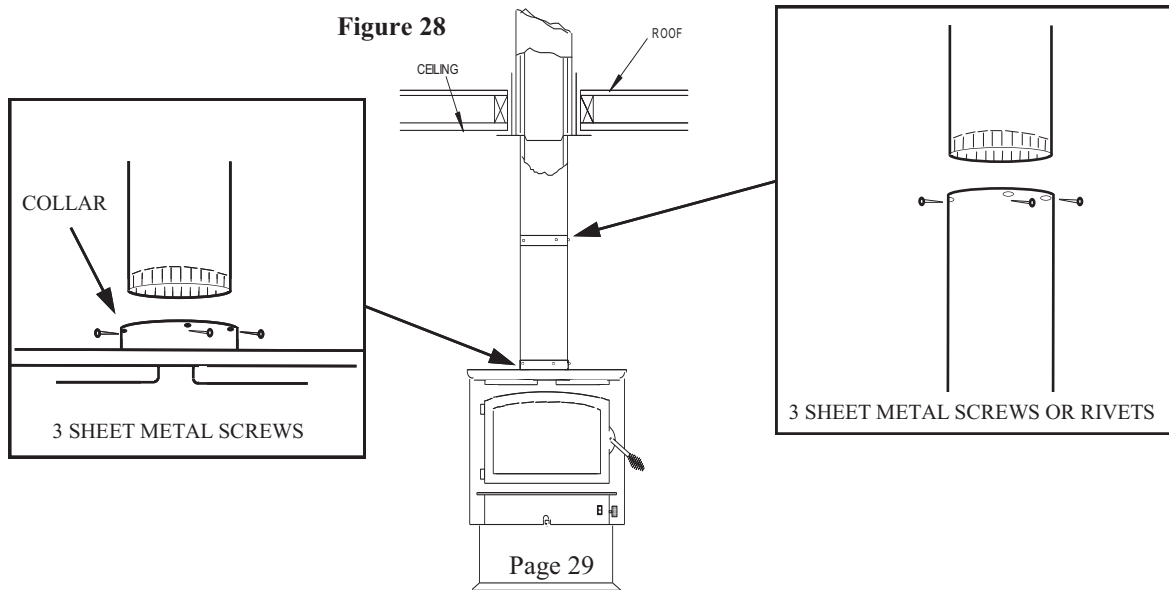

FINAL CHECK

1. Recheck specified clearances.
2. Remove all foreign material from firebox area.
3. Open primary air draft.
4. Plug power cord into a 115V AC outlet when using with optional motor. Do not run cord under unit or in high traffic areas.
5. Place crumpled pieces of newspaper in the stove. Light it and close the door. Ensure that stove draws properly through primary draft.
6. Check for smoke leaks around the door.

CAUTION

Open the door and check for smoke escaping from the front of stove. Smoking usually indicates a defective or poorly positioned chimney. Some chimneys with a marginal draft can be preheated by lighting newspaper and holding it near open damper with a poker or fire tong. Once the chimney heats up, a proper draft can usually be obtained.

If a thorough review of the Troubleshooting Guide in the manual does not reveal problem, contact your dealer for assistance.

CAUTION

The unit is painted with a specially formulated high temperature paint that cures during the first two or three firings. You may notice a slight smoking effect and an odor of burning paint when you build the first fires. This is normal and is not a cause for alarm. In some cases, these fumes will activate a smoke alarm. Opening a window near the unit will allow these fumes to escape. DO NOT build a large, roaring fire until this curing is complete or heater finish may be damaged.

SECTION V

ALCOVE INSTALLATION AND CLEARANCES

Select an installation location that will give the best airflow
from the front of the heater to the remainder of the home

PREPARING THE STOVE FOR INSTALLATION

1. Inspect the unit for any obvious physical damage.
2. Plug the power cord into a 115V AC outlet to test the motor and fan when optional motor is being used. Do not run power cord under unit or in high traffic areas.
3. Check the primary air draft control to ensure that it slides freely.(See Figure 29).
4. Remove any items from within firebox. Spread a dropcloth on door behind heater. Next, tilt heater so that back is on the drop cloth.
5. If leg kit is to be used follow steps 1-6.
6. Then obtain four legs, attach legs to holes in bottom of unit with bolts and washers supplied with the leg kit. (See Figure 29).
7. Open freestanding kit and obtain stand. Place stand against bottom of heater (angle side to heater).Center stand front to rear and also center stand left and right. Mark screw locations on bottom of the stove through outer holes of stand mounting angles. Set stand aside and drill four 7/32" holes in heater bottom.Then mount stand to bottom of heater with screws provided. (See Figure 30).
8. Obtain four (4) 3/16" self-tapping screws and secure the stand to the heater.
9. Reposition the heater to the upright position.

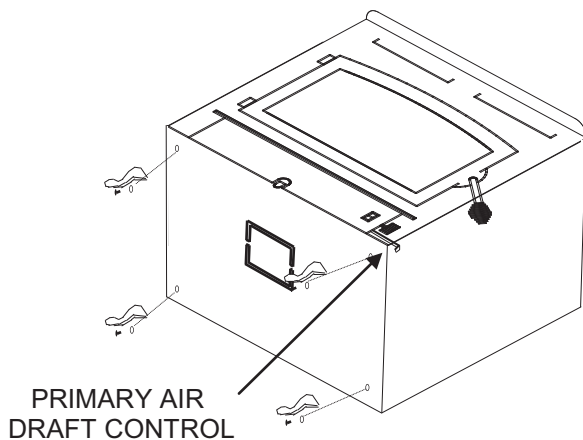

Figure 29

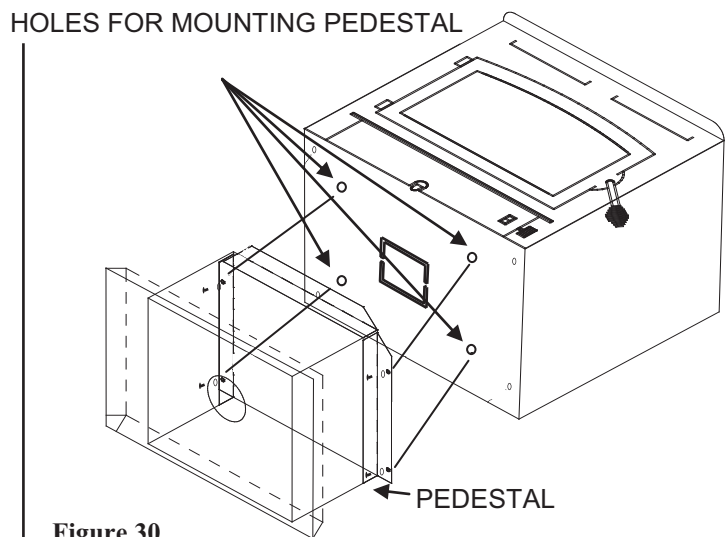

Figure 30

Chimney

This model is designed for connection to any listed 2100° UL103 HT chimneys and parts. Follow chimneys manufacturer's instructions carefully.

This room heater must be converted to (1) a chimney complying with the requirements for Type HT chimneys in the Standard for chimneys, Factory-Built, Residential, Type and Building Heating Appliance, UL 103, or (2) a code approved masonry chimney with a flue liner.

Floor Protection:

Floor protection must be 3/8” minimum thickness non-combustible material or equivalent.

How to use alternate materials and how to calculate equivalent thickness

An easy means of determining if a proposed alternate floor protector meets requirements listed in the appliance manual is to follow this procedure:

1. Convert specification to R-value:
 - R-value is given—no conversion is needed.
 - K-factor is given with a required thickness (T) in inches:
C-factor is given: $R=1/C$
2. Determine the R-value of the proposed alternate floor protector.
 - Use the formula in step (1) to convert values not expressed as “R”
 - For multiple layers, add R-values of each layer to determine the overall R-value.
3. If the overall R-value of the system is greater than the R-value of the specified floor protector, the alternate is acceptable.

Example:

The specified floor protector should be 3/4” thick material with a K-factor of 0.84.

The proposed alternate is 4” brick with a C-factor of 1.25 over 1/8” mineral board with a K-factor of 0.29.

Step (a): Use formula above to convert specification to R-value. $R = 1/K \times T = 1/0.84 \times .75 = 0.893$

Step (b): Calculate R of proposed system. 4” brick of $C=1.25$, therefore $R_{brick} = 1/C = 1/1.25 = 0.80$ 1/8” mineral board of $K = 0.29$, therefore $R_{min.bd.} = 1/0.29 \times 0.125 = 0.431$

Step (c): Compare proposed system R of 1.231 to specified R of 0.893. Since proposed system R is greater than required, the system is acceptable.

Definitions:

$$\text{Thermal conductance} = C = \frac{\text{Btu}}{(\text{hr})(\text{ft}^2)(\text{°F})} = \frac{\text{W}}{(\text{m}^2)(\text{°K})}$$

$$\text{Thermal conductance} = K = \frac{(\text{Btu})(\text{inch})}{(\text{hr})(\text{ft}^2)(\text{°F})} = \frac{\text{W}}{(\text{m})(\text{°K})} = \frac{(\text{Btu})}{(\text{hr})(\text{ft})(\text{°F})}$$

$$\text{Thermal conductance} = R = \frac{(\text{ft}^2)(\text{hr})(\text{°F})}{\text{Btu}} = \frac{(\text{m}^2)(\text{°K})}{\text{W}}$$

Install in accordance with 24 CFR, Part 3280 (HUD).

HOW TO LOCATE CHIMNEY EXIT AND INSTALL

Alcove Installation

Vertical Exit using (6" DVL Close Clearance pipe and any Listed 2100° UL 103 HT chimney).

With optional close clearance shield and pipe shield. NOTE: For installation of optional close clearance shields and pipe shield (See Page 35).

NOTE: For minimum clearances (See Page 34, Figure 31).

1. Suspend a plumb bob from ceiling above unit so that weight is hanging in the center of flue exit. (A small weight on a string will serve as a plumb bob). Mark ceiling where string is suspended to locate the center of the chimney.
2. After locating center of hole, install the ceiling support box, chimney or chimney connector, flashing and rain cap, per chimney manufacturer's instructions and local building codes for installation through combustible walls or ceilings.
3. Now connect stove and ceiling support box using DVL close clearance pipe. Connect each section per manufacturer's instructions. Secure each section to each other using minimum (3) sheet metal screws or rivets. DVL close clearance is to be connected with (3) sheet metal screws or rivets to connector collar on heater.(See Page 34,Figure 32).
4. NOTE: If your local code requires outside air for residential installation, refer to pages 15-16 for outside air installation.

ALCOVE INSTALLATION AND CLEARANCES

**Vertical exit using (6" DVL Close Clearance pipe and any listed 2100° UL 103 HT. TYPE Chimney).
With optional close clearance shield and pipe shield.
Model 21 minimum clearance to combustibles.**

Figure 31

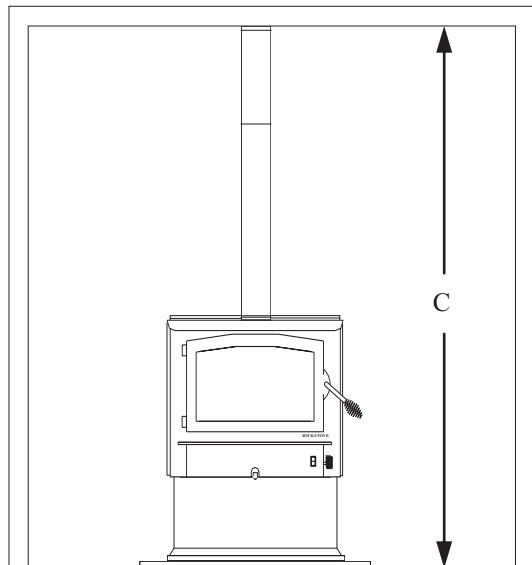
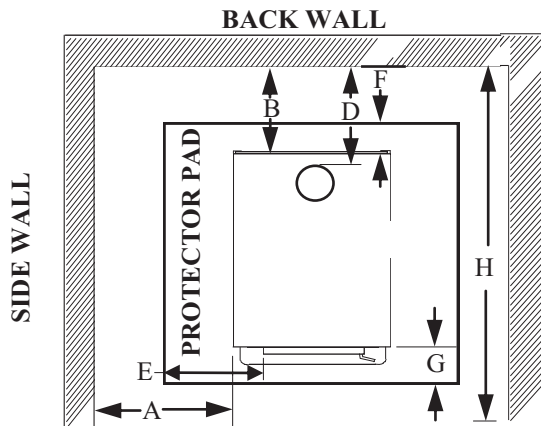

A B C D E F G H

MODEL 21 19" 7" 84" 8.5" 8" 6" 16" 48"

Figure 32

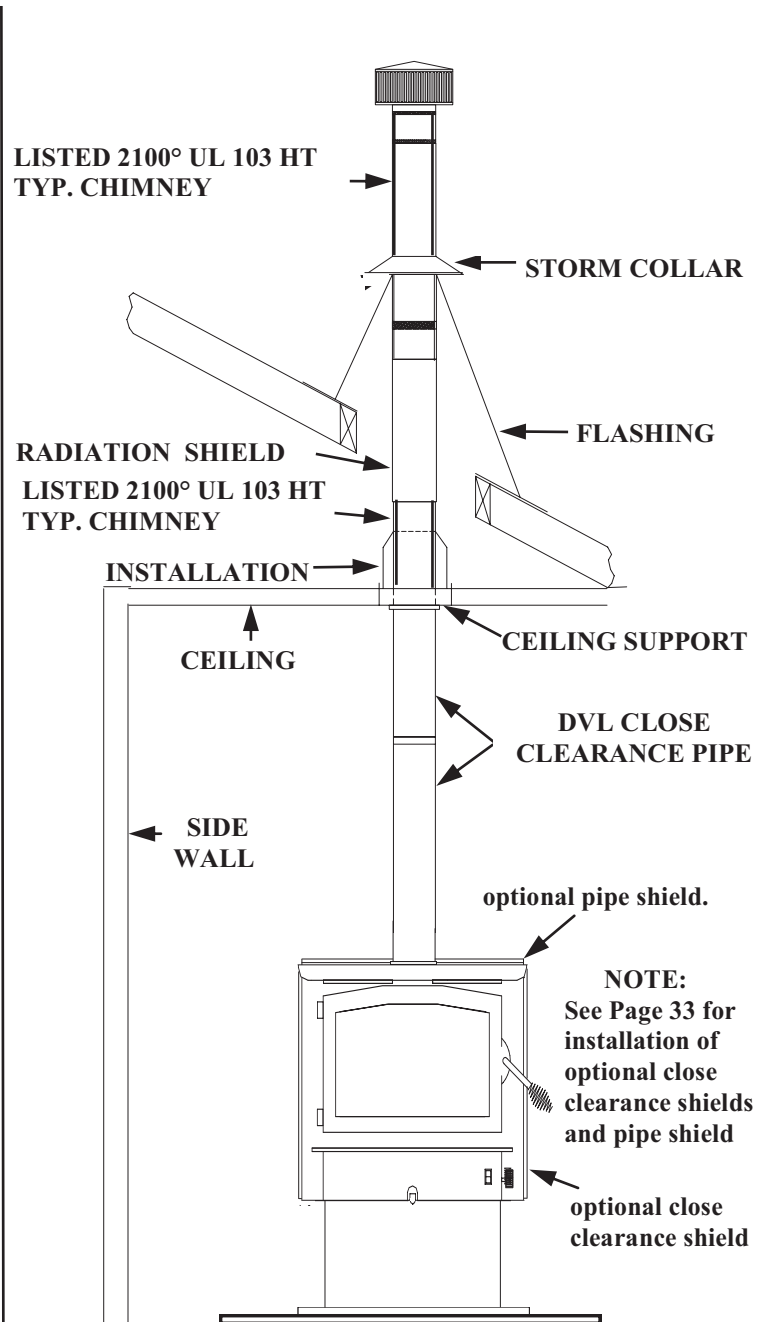

NOTE: All clearances are to combustibles with optional close clearance shields and pipe shield, using DVL Close Clearance pipe and minimum floor protector.

Installation of (Optional) Close Clearance Shields and Pipe Shield

1. Taking close clearance side shields, hold up to side of stove leaving 1/4" gap between shield and top of stove.
2. Make reference mark in center of pre-punched hole in top & bottom rear of shield. Drill two (2) 3/32" holes in back of unit each side. Install shield using two(2) 10-16 x 3/4" Tek. self drilling screws in through shield into stove back for each side shield. (SEE PICTURE BELOW)
3. Drill two(2) 3/16" holes in the sides of stove where shield meets front side. Install side of shields using two(2) 1/4-14 X 3/4" Tek. self drilling screws (TWO per front side). (SEE PICTURE BELOW)
4. Next loosen two (2) top screws holding side shield at rear top. Insert pipe shield where back shield and top rear side shield meets. Leave a 1" gap from the top of stove to the pipe shield, tighten screws.(SEE PICTURE BELOW)

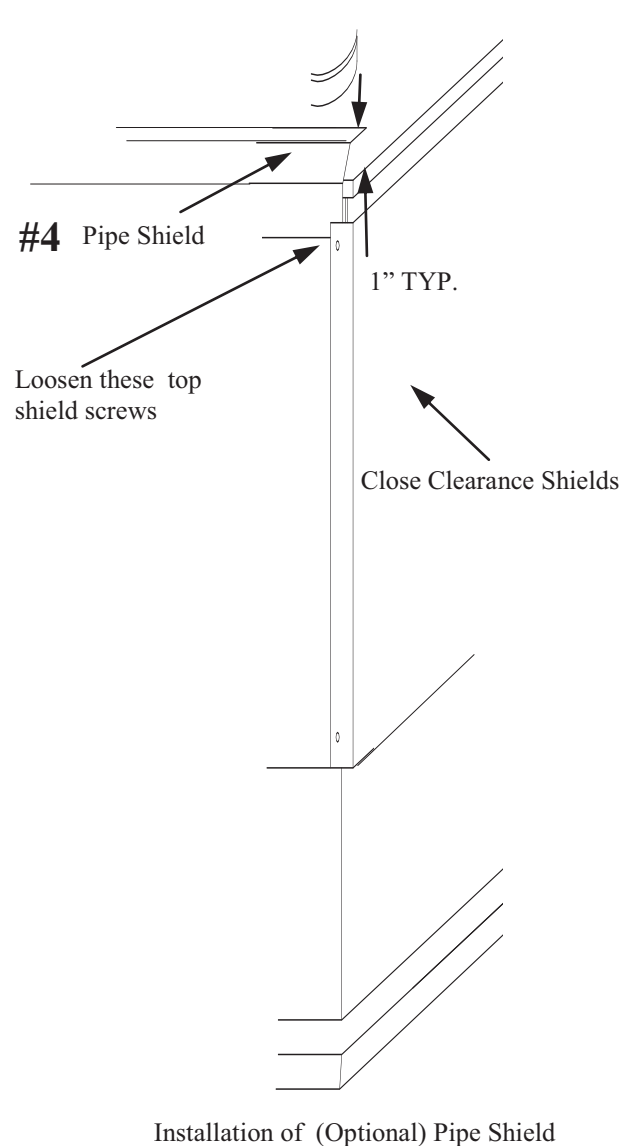
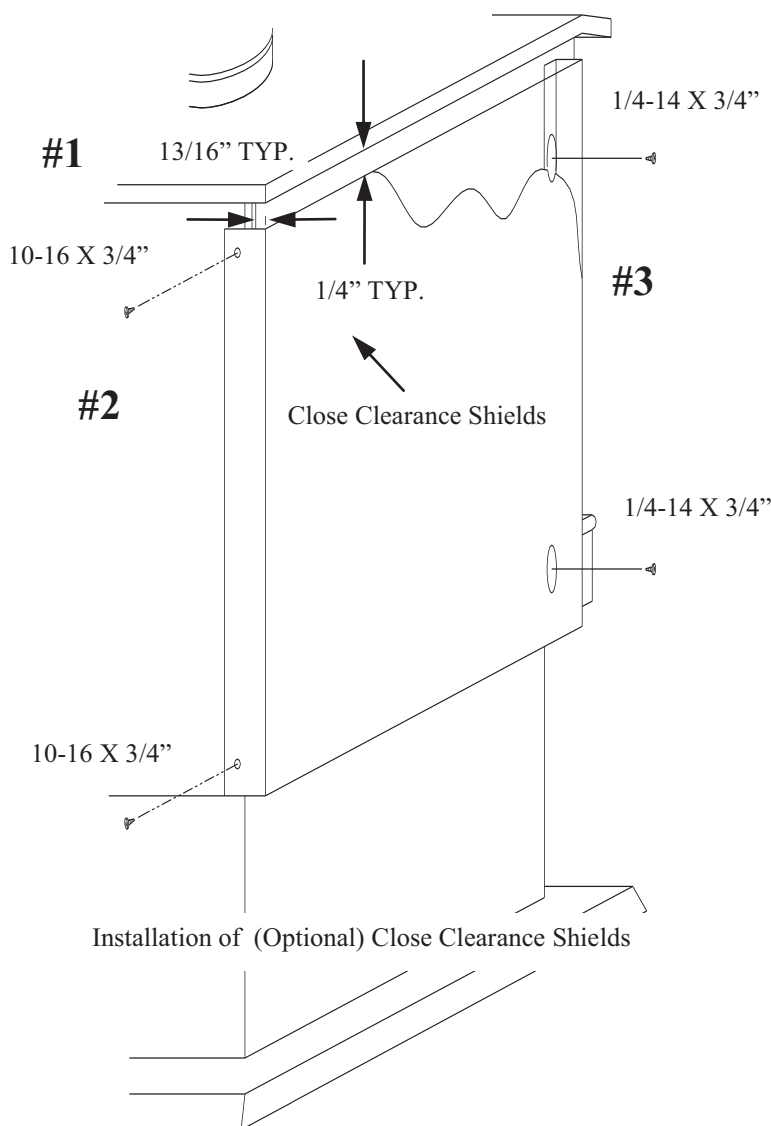

FINAL CHECK

1. Recheck specified clearances.
2. Remove all foreign material from firebox area.
3. Open primary air draft.
4. Plug power cord into a 115V AC outlet when using with optional motor. Do not run cord under unit or in high traffic areas.
5. Place crumpled pieces of newspaper in the stove. Light it and close the door. Ensure that stove draws properly through the primary draft.
6. Check for smoke leaks around the door.

CAUTION

Open door and check for smoke escaping from front of stove. Smoking usually indicates a defective or poorly positioned chimney. Some chimneys with a marginal draft can be preheated by lighting newspaper and holding it near the open damper with a poker or fire tong. Once the chimney heats up, a proper draft can usually be obtained.

If a thorough review of the Troubleshooting Guide in the manual does not reveal the problem, contact your dealer for assistance.

CAUTION

The unit is painted with a specially formulated high temperature paint that cures during the first two or three firings. You may notice a slight smoking effect and an odor of burning paint when you build the first fires. This is normal and is not a cause for alarm. In some cases, these fumes will activate a smoke alarm. Opening a window near the unit will allow these fumes to escape. DO NOT build a large, roaring fire until this curing is complete or the heater finish may be damaged.

SECTION VIII

WOOD HEATER SAFETY

Certain safety hazards are inherent in any wood heater installation. You should be aware of these so that a safe and proper installation can be made.

1. **FAULTY CHIMNEY:** An older masonry chimney should be thoroughly checked to be sure there are no holes or weak spots which could allow sparks or hot gases to escape.
2. **HEAT CONDUCTION:** Placing combustible materials too close to a heater or chimney can be a fire hazard.

By keeping these particular hazards in mind as you install and use your room heater you can ensure a safe, reliable installation.

The chimney and chimney connector should be inspected once every two months. Any build-up of soot should be removed to prevent risk of a chimney fire. To remove chimney or chimney connector, remove screws or fasteners then remove pipe and clean with steel brush. Replace chimney or chimney connector. Replace screws and/or fasteners.

CAUTION

NEVER USE GASOLINE, GASOLINE TYPE LANTERN FUEL, KEROSENE, CHARCOAL LIGHTER FLUID OR SIMILAR LIQUIDS TO START OR "FRESHEN UP" A FIRE IN THE HEATER. KEEP ALL SUCH LIQUIDS WELL AWAY FROM STOVE WHEN IT IS IN USE. ALL FLUIDS OF THIS TYPE GIVE OFF VOLATILE FUMES AND CAN AND WILL EXPLODE! DON'T TAKE A CHANCE WITH SAFETY OF YOUR HOME AND FAMILY.

CAUTION: Never remove ashes from heater with blower running.

DISPOSAL OF ASHES: Ashes should be placed in a metal container with a tight fitting lid. The closed container of ashes should be placed on a noncombustible floor or on the ground, well away from all combustible materials pending final disposal. If ashes are disposed of by burial in soil or otherwise locally dispersed, they should be retained in closed container until all cinders have thoroughly cooled.

CREOSOTE—FORMATION AND NEED FOR REMOVAL: When wood is burned slowly, it produces tar and other organic vapors, which combine with expelled moisture to form creosote. The creosote vapors condense in the relatively cool chimney flue of a slow-burning fire. As a result, creosote residue accumulates on flue lining. When ignited this creosote makes an extremely hot fire.

SECTION VI OPERATION/EFFICIENCY

1. "To maximize the efficiency of your wood stove make sure it is sized properly for the space you plan to heat. An oversized stove will burn and be forced to burn at a lower and dirtier burn rate. Consult with your dealer for sizing your stove correctly.
2. Use dry, seasoned wood only. Recommended fire wood length 10" front to back. Using wet wood will greatly reduce your efficiency.
3. Consult with your installer/dealer to correctly place the stove in your home. An incorrectly placed stove can greatly reduce efficiency.

Maximizing the efficiency of your stove will heat your house quickly, burn cleaner and use less wood.

Use dried split wood (6-12 months) and placed from front to back position in heater. (See Page 5 Bottom Picture).

"This wood heater has a manufacturer-set minimum low burn rate that must not be altered. It is against federal regulations to alter this setting or otherwise operate this wood heater in a manner inconsistent with operating instruction in this manual."

NOTE: "Following all suggested operating and maintenance procedures will help minimize visual emissions.

The following steps will serve as a guide for operating your stove.

BUILDING A FIRE

1. Open door.
2. Open primary air control. Primary air intake draft control is located at center bottom side of hearth. It is operated by moving handle **IN** to open (to allow air into firebox) or **OUT** to control or close off the firebox. (Figure 35 primary air control).

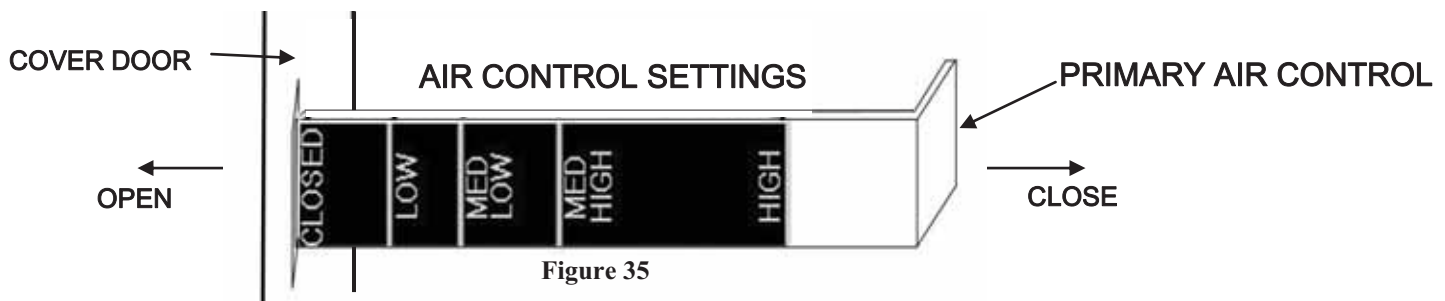

1. Twist two pieces of non-colored newspaper into a roll and place them on floor of firebox.
NOTE: Do not use grate or elevate fire. Build wood fire directly on inner bottom of fire box.
2. This model is not designed for use of grates, andirons or other methods of supporting fuel.
3. Lay several pieces of dry kindling on top of newspaper.
4. Place three or four small pieces of firewood, 2"-3" in diameter, on top of kindling.
5. Light newspaper in front. Close and latch door. Don't leave fire unattended at this point. The draft system of heater should start quickly. It may be necessary to preheat chimney to get draft started. To do this, open door and add newspaper to top rear of wood. Light or let this paper ignite and allow to burn while holding the door slightly cracked. Once draft has started, close and lock door. You are over-heating the unit if the chimney and or connector glows red.
6. **NOTE: After embers and a coal bed have been established, load heater with seasoned natural hard wood, placing it front to rear.**

NOTE: THE FUELING DOOR MUST REMAIN CLOSED DURING OPERATION.

Your stove is equipped with an automatic thermostat. When stove gets hot enough, thermostat will activate room air blower. Set fan speed on low, when burning on low, med-low or med-high. Set fan speed on high when burning on high.

NOTE: When refueling or removing ashes turn "OFF" room air blower. Be sure to turn room air blower back on when finished.

NOTE: Do not run power cord underneath heater or in walk way or heavy traffic areas.

GUIDE TO THE DIFFERENT BURNING QUALITIES OF WOOD

Type of Wood	Ease of Starting	Coaling Qualities	Amount of Sparks
Apple	Poor	Excellent	Few
Ash	Fair	Good	Few
Beech	Poor	Good	Few
Birch	Good	Excellent	Moderate
Cherry	Poor	Excellent	Few
Cedar	Excellent	Poor	Many
Elm	Fair	Good	Very Few
Hemlock	Good	Low	Many
Hickory	Fair	Excellent	Moderate
Locust	Poor	Excellent	Very Few
Maple	Poor	Excellent	Few
Oak	Poor	Excellent	Few
Pine	Excellent	Poor	Moderate

The Maine Audubon Society recently charted the heat produced by a wood fire. They noted that heat produced by a wood fire varies greatly with kind of wood burned. Beech is considered best wood for a fire. A cord of well-seasoned Beech will produce as much heat as 169 gallons of fuel oil; Sugar Maple and Red Oak produce as much heat as 166 gallons of fuel oil; followed by White Ash 154; American Elm 130; White Birch 124; and White Pine 94.

HOW TO REPLACE MOTOR, THERMOSTAT, & RHEOSTAT INSTALLATION INSTRUCTIONS

STEP 1: REMOVE ACCESS DOOR PANEL LOCATED AT BOTTOM OF UNIT. REMOVE THE 2 SCREWS AIR CONTROL BRACKET & ROD USING A 3/8" DRIVER WITH DRILL. THIS METHOD IS ONLY RECOMMENDED WHEN STOVE IS INSERTED IN FIREPLACE. YOUR MOTOR ASSEMBLY COMES WITH A BRACKET ALREADY ATTACHED TO THE MOTOR. ALIGN THE HOLES IN MOTOR BRACKET WITH HOLES IN MOTOR MOUNT. SECURE BRACKET WITH TWO 1/2" HEX HEAD SCREWS PROVIDED.

STEP 2: REMOVE THE PROTECTIVE BACKING OFF THE RHEOSTAT INDICATING LABEL AND PLACE THE HOLE IN CENTER OF LABEL TO LINE UP WITH HOLE IN THE RIGHT SIDE HEARTH SUPPORT AS YOU FACE THE UNIT. PLACE LABEL SO "OFF" POSITION IS AT THE 8 O'CLOCK POSITION AND "LOW" IS AT 4 O'CLOCK POSITION. MOUNT RHEOSTAT BY PLACING IT BEHIND HEARTH SUPPORT WITH WIRES ON BOTTOM SIDE. PLACE PLASTIC STUD SUPPORT WITH WIRES ON BOTTOM SIDE. PLACE PLASTIC STUD THROUGH HOLE IN BRACKET AND SECURE WITH RHEOSTAT MOUNTING NUT. PLACE INDICATOR KNOB ON PLASTIC STUD.

STEP 3: REMOVE STRAIN RELIEF COVER FROM HEARTH SUPPORT AND DISCARD. MOUNT POWER CORD STRAIN RELIEF HOLDER IN COVER MOUNTING HOLES. PLACE THERMOSTAT BEHIND "C" CLIP LOCATED UNDER HEARTH TO THE RIGHT OF MOTOR. USE CABLE TIE TO SECURE LOOSE WIRES.

STEP 4: REINSTALL THE ROD AND BRACKET, MAKE SURE YOU PLACE THE ROD IN THE HOLDER THAT IS TOWARDS THE BACK OF THE STOVE. REINSTALL ACCESS DOOR PANEL.

STEP 5: PLUG POWER CORD INTO SUPPLY OUTLET. PLACE RHEOSTAT INDICATING KNOB IN POSITION DESIRED. WHEN HEATER REACHES TEMPERATURE, FAN WILL OPERATE AT DESIRED SPEED.

IT WILL BE NECESSARY TO OCCASIONALLY CLEAN FAN BLADES FOR MAXIMUM PERFORMANCE. DUST AND DIRT BUILDUP ON FAN BLADES WILL SHORTEN MOTOR LIFE AND RESTRICT AIR FLOW WHICH COULD DAMAGE MOTOR.

NOTE: ROUTE POWER CORD TO PREVENT DAMAGE TO CORD INSULATION FROM HEAT AND SHARP OBJECTS. KEEP CORD OUT OF THE WAY OF TRAFFIC TO PREVENT DAMAGE CAUSED BY TRIPPING, ECT.

MOTOR -THERMOSTAT-RHEOSTAT REPLACEMENT

To replace Motor, Thermostat, Rheostat follow steps below.

STEP 1

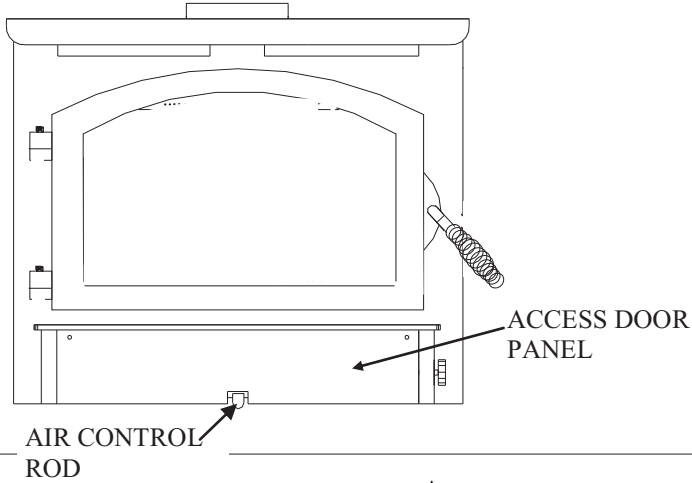

STEP 2

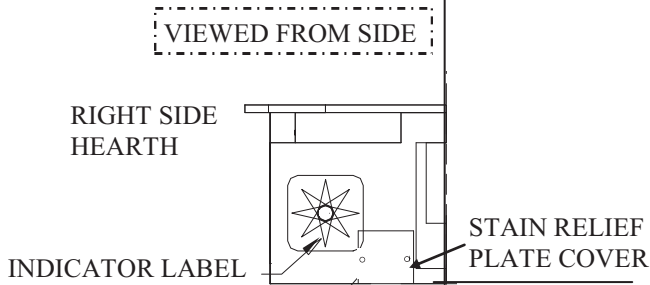

STEP 3

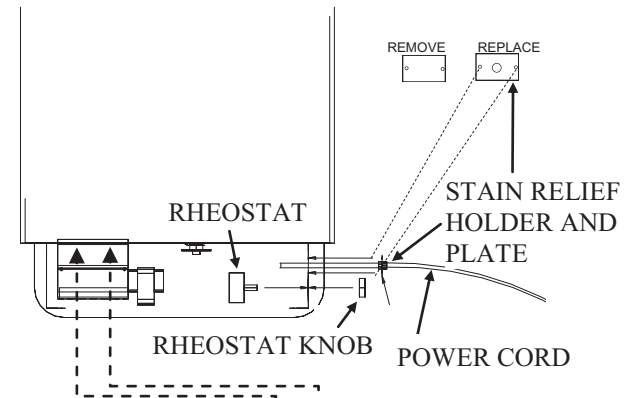
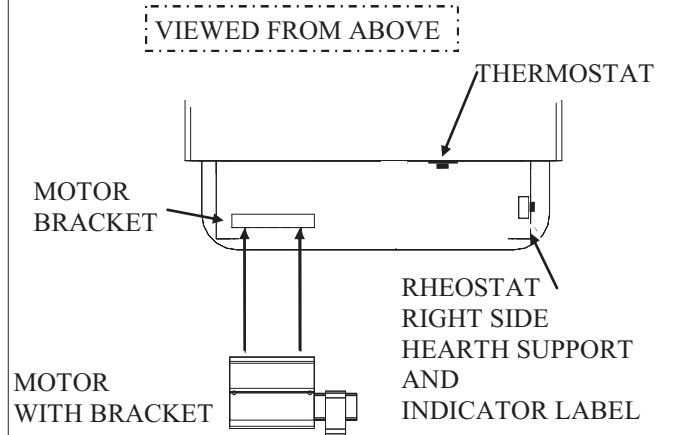

WIRE DIAGRAM

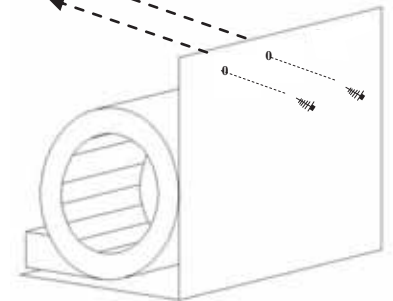
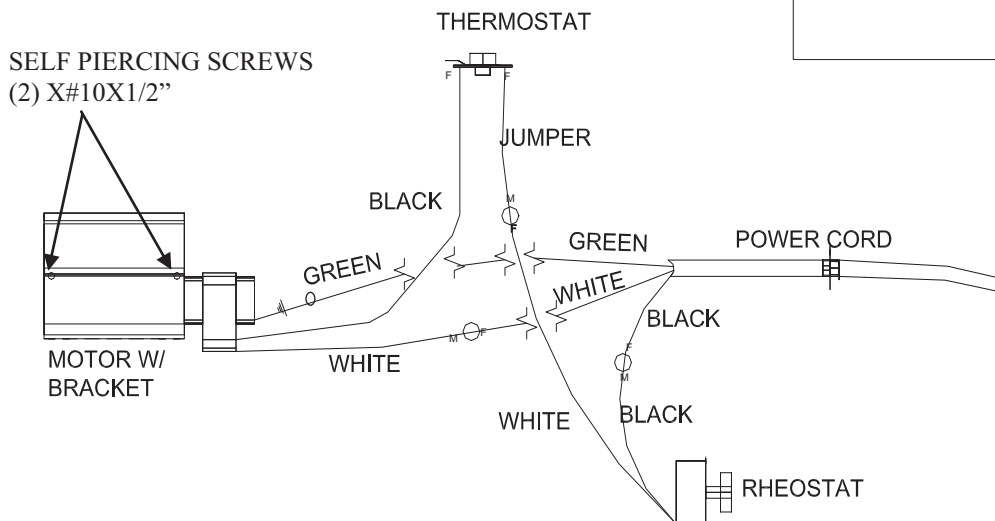

SELF PIERCING SCREWS
(2) X#10X1/2"

ASSEMBLY PARTS

- 1 - MOTOR (NON-CAT)
- 1 - MOTOR BRACKET
- 6 - #10 - 16 X 1/2" HEX HEAD
- 1 - #6 - 32 X 1/2" SLOT HEAD SCREW
- 5 - 1/8" X 1" BLACK FLAT GASKET WITH ADHESIVE
- 1 - JUMPER WIRE 4" MALE & FEMALE TERMINAL
- 1 - 110 THERMOSTAT
- 1 - RHEOSTAT
- 1 - RHEOSTAT NUT
- 1 - RHEOSTAT INDICATOR KNOB
- 1 - RHEOSTAT LABEL
- 1 - POWER CORD
- 1 - STRAIN RELIEF
- 1 - 6" WIRE TIE
- 1 - STRAIN RELIEF HOLDER (METAL)
- 1 - WIRE TIE FOR POWER CORD
- 1 - INSTRUCTIONS

SECTION VII MAINTENANCE

BRICK LAYOUT

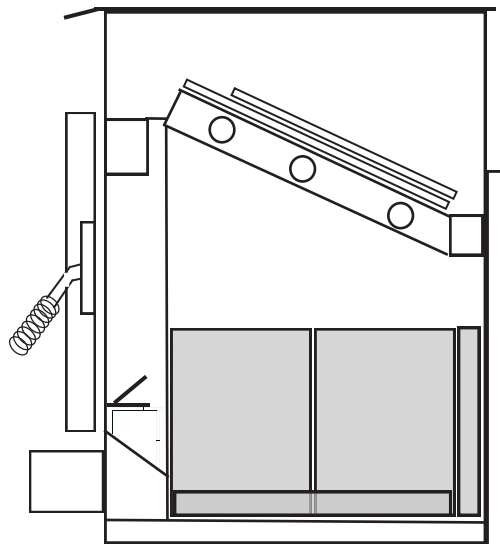
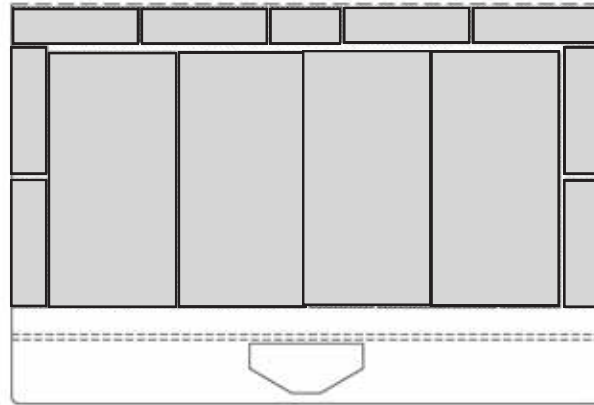

NOTE: “This wood heater needs periodic inspection and repair for proper operation. It is against federal regulations to operate this wood heater in a manner inconsistent with operating instructions in this manual.”

MAINTENANCE

SECONDARY AIR TUBES REPLACEMENT

(Replacing secondary air tubes)
COLD STOVE

1. Unplug heater from 115V AC outlet.
2. Put drop cloth down.
3. Empty ashes.
4. Remove air tubes. The (3) secondary air tubes are located in top of burn chamber. (NOTE, front/rear air tubes have 24 holes per tube, middle air tube has 12 holes per tube) On right side of tubes you will find a cotter pin. To remove air tube remove cotter pin and slide tube to left, it will drop down, slide tube to right it should come out. (See Figure Below).
5. Replace air tube. On one end of tube you will find a hole drilled on both sides through the tube. This end goes to right side. Place tube in left tube holder and slide other end of tube into right side tube holder. Line up through hole in air tube with tube holder bracket and replace cotter pin and bend slightly so it wont fall out.

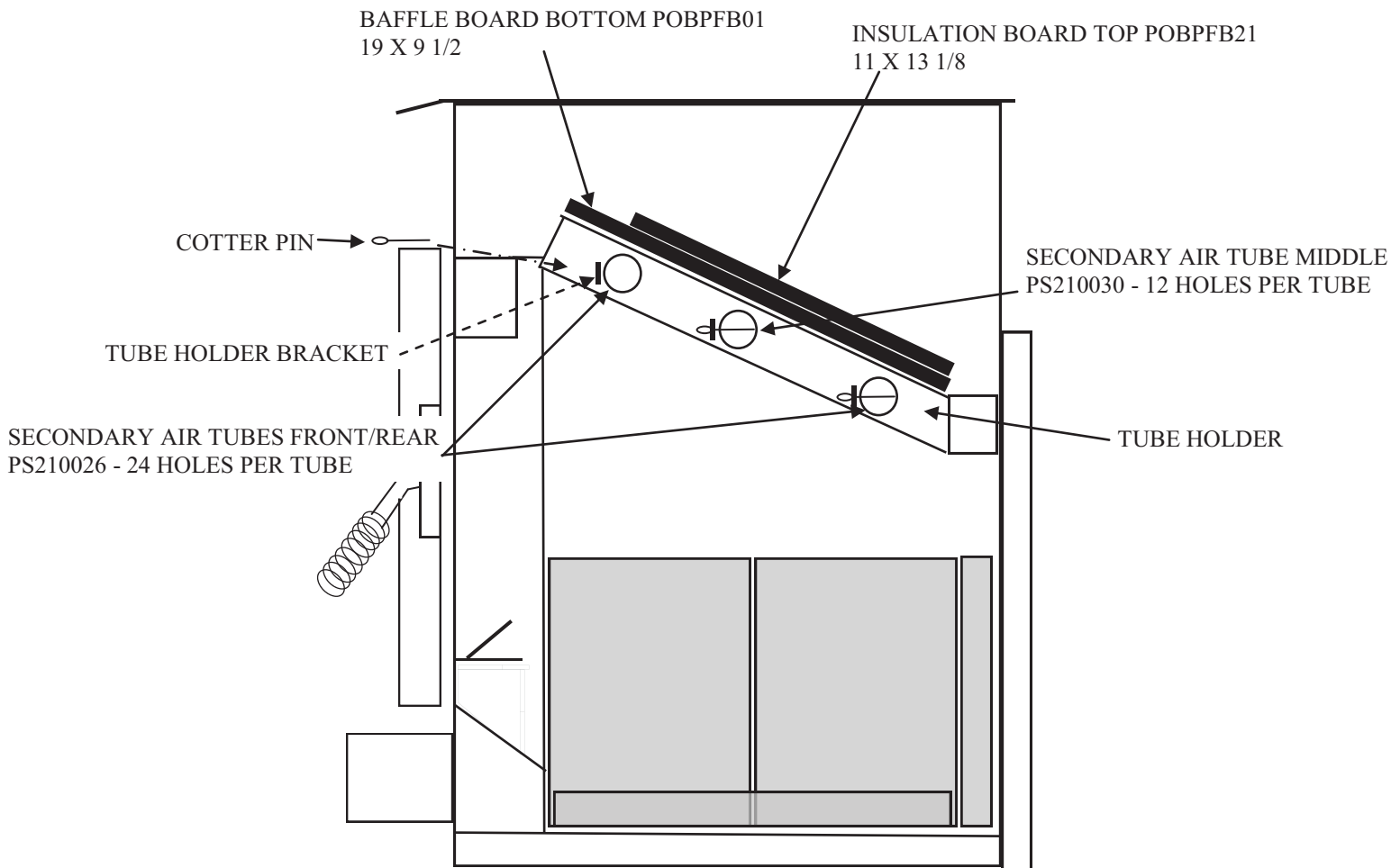

Figure 32

BAFFLE BOARDS REPLACEMENT

(Replacing baffle board)
COLD STOVE

1. Unplug heater from 115V AC outlet.
2. Put drop cloth down and empty ashes.
3. Repeat steps 1-5 from above removing 1st tube only.
4. The baffle boards run long ways front to rear. Lift and slide baffle board toward the front. (See Figure Above).
5. Replace baffle board making sure the board is seated on top of air tubes and behind front baffle board holder. After replacing both baffle boards replace front air tube following step 5 from secondary air tube replacement.

DOOR GASKET REPLACEMENT (COLD HEATER)

To replace deteriorated gaskets, following steps must be taken to ensure proper installation of gaskets.

1. Obtain proper gaskets and silicone glue from your local dealer.
2. Using pliers, remove any worn and deteriorated gaskets.
3. Using a scraper, wire brush and sandpaper or steel wool, clean glue and gasket residue from door frame.
4. Measure and cut gaskets to length. Care should be taken not to stretch gaskets. What you want is a full and loose gasket weave after attachment to framing.
5. Obtain silicone glue and run a 3/16" bead inside door frame.
6. Obtain gasket (s) and place in gasket channel areas starting at lower right corner, see below. Use a technique which assures that gasket is applied in a loose like manner. **DO NOT STRETCH GASKETS.**
7. After gasket (s) are applied to glue, use your finger and go over all gasket gently pressing gasket to the channel. Use same pressure against gasket so that final result is an evenly applied gasket.
8. Leave door open and allow at least two (2) hours for glue to dry.
9. Once gaskets are checked, heater is ready for use.
10. This should be done annually. Allowing gaskets to deteriorate can cause over-firing and shorten burn time.

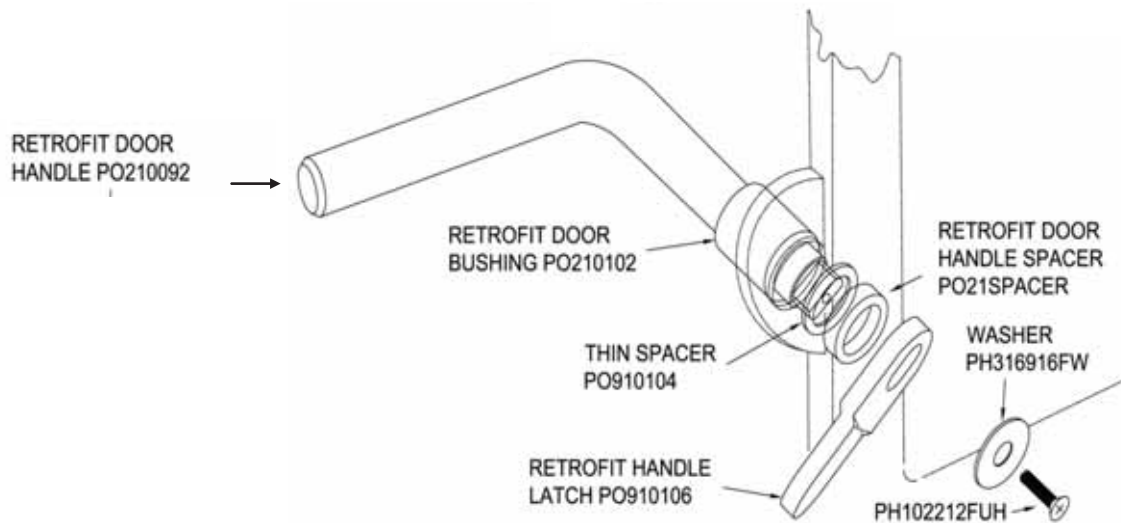
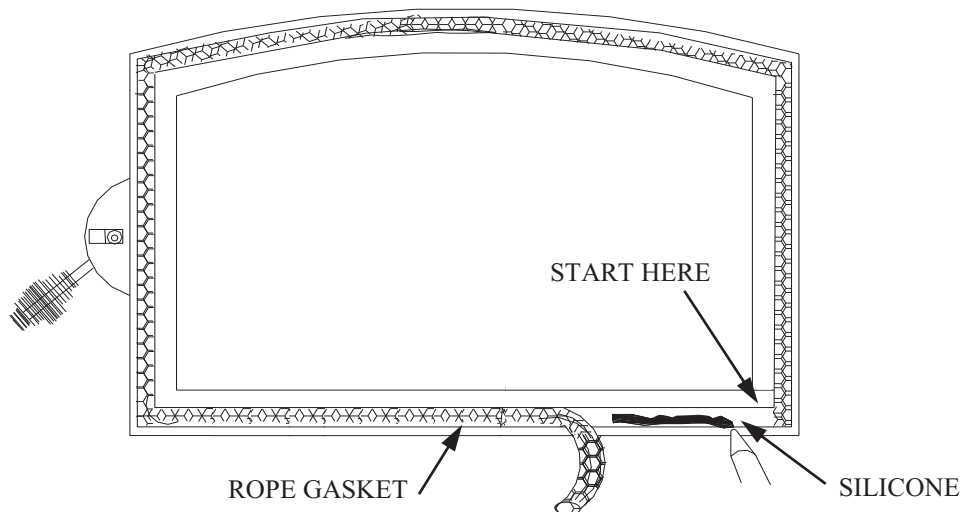

CHECK CHIMNEY

- A. Chimney should be inspected twice a year.
- B. The chimney should be cleaned as necessary to remove creosote, soot, leaves, birds' nests, etc.

⚠ NOTE: A chimney cap should be installed to prevent moisture from entering chimney, to prevent sparks and burning materials from escaping chimney and to keep birds and foreign materials from entering.

*** NOTE:** Some areas may require an approved spark arrestor.

Before sweeping the chimney a few steps must be done. Put drop cloth down.

1. Open feed door and remove the Front Secondary Air Tube by removing cotter pin up in right side facing stove. Remove Air Tube and cotter pin, set aside.
2. Remove the two Baffle Board's and set aside.
3. Close feed door for cleaning chimney so debris don't fall out feed door while cleaning chimney.
4. Creosote and debris will fall into the bottom of the stove unit from the cleaning.
5. Clean out all the creosote and debris from inside stove unit, if any is left from clean sweeping chimney.
6. Replace Baffle Board's and Front Secondary Air Tube reverse steps 1-3

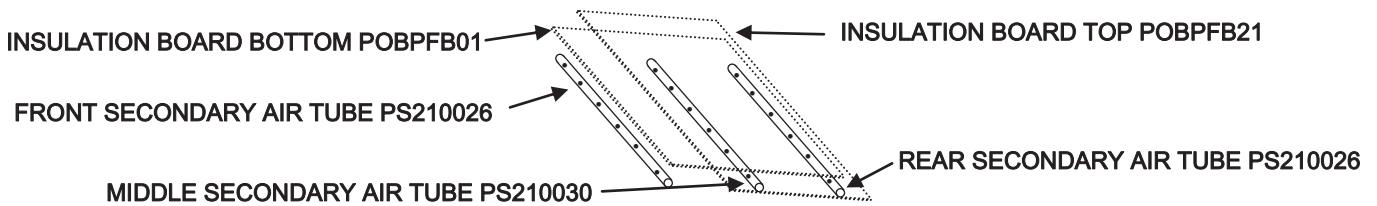

CLEANING THE HEATER

- A. The heater should not be cleaned with any type of detergent as most all detergents have an oil base and cannot be painted over.
- B. The heater should be lightly sanded with fine sandpaper or steel wool, then repainted or touched up with high temperature paint.
- C. If the heater is located in a moist or damp location, check thoroughly for signs of condensation during times when heater is not in use.
- D. When heating season is over, heater should be cleaned out completely with a wire brush or cloth to help eliminate ash and burned wood smell.

CARE OF GLASS DOOR

The glass door on your heater permits you to enjoy the beauty of the fire while retaining efficiency of your heater. Although brand of glass used in heater door has well established and recognized heat resistant and strength characteristics, it can be broken through improper care. To achieve maximum utility and safety of your glass door, we advise that you observe following use and safety tips:

1. Inspect glass regularly for cracks or breaks. If you detect a crack or break extinguish fire immediately and return door to your dealer for glass replacement before further use.
2. Do not slam heater door or otherwise impact glass. When closing door, make sure that no logs or other objects protrude or impact against glass.
3. Do not clean glass with materials which may scratch it (such as steel wool) or otherwise damage glass. Scratches on the glass can develop into cracks or breaks.

The glass can be cleaned with a commercial oven cleaner, providing it does not contain abrasives. A build-up on glass that has been there for a considerable length of time can be burned off with a propane torch or straight razor blade. Use protective gloves when using razor.

SECTION IX TROUBLESHOOTING

PROBLEM	POSSIBLE CAUSE	SOLUTION
Sluggish Heater	Obstruction in chimney	Check for and remove obstruction
	Improperly sealed trim kit or direct connect kit	(a) Check trim kit gasketing seal to fireplace and gasket as necessary to seal unit. Gasket under front bottom of stove if needed. (b) Check seal if using direct connect and correct
	Manual damper in chimney is closed	Open manual damper and wire shut with stainless steel wire or remove damper
	Wet or unseasoned wood being burned	Burn dried natural seasoned hard wood
	Poor chimney draft	Improper chimney height or wrong size flue is being used. Cooler temperatures caused by external chimney

PROBLEM	POSSIBLE CAUSE	SOLUTION
High fuel consumption	Improper regulation of draft or inlet air	(a) Close inlet air control as much as possible to maintain desired heat output (b) Check gaskets, reinstall fiberglass gasketing round doors and glass as necessary
	Improper door fitting	Check door gasket, check adjustment of door latch
Backpuffing	Gusts of Wind	(a) Smoke shelf in chimney is filled with creosote & ash (b) Chimney may need wind diverter. Raise chimney for better draft
Smoke rollout when heater door is opened	Wind gusts blowing down the chimney	(a) Smoke shelf in chimney is filled with creosote & ash (b) Chimney may need wind diverter. Raise chimney for better draft
	Opening heater door too fast	Crack door for 15 seconds before fully opening door

REPLACEMENT PARTS

PAGE 1

NOTE: For replacement parts use only manufacturer's specified parts.

Description	Quantity	Part No.
1. Door Gold	1	PC212400-G
2. Door Black	1	PC212400-B
3. Door Pewter	1	PC212400-P
4. Door Handle	1	PO210092
5. Retrofit Door Bushing	1	PO210102
6. Thin Spacer	1	PO910104
7. Retrofit Door Handle Spacer	1	PO21SPACER
8. Retrofit Handle Latch	1	PO910106
9. Door Latch Washer	1	PH316916FW
10. Door Latch Screw	1	PH102212FUH
11. Door Roping 3/4"	1	RPFR2LD.750G
12. Glass Gasket	1	RPTKW197X.875GA
13. Door Glass	1	PG2124GL
14. Firebrick	1	PR900050
15. Glass Clips Small	1	PO210767
16. Glass Clip Screws Hex/Washer Slot Machine Screw 10-32 X 1/2"	10	PH103211HWHMC
17. Cotter Pin	3	PH182CPSS
18. Spring Handle	1	PO100150
19. Hearth Trim Black	1	PO810705-BLK

REPLACEMENT PARTS

PAGE 2

NOTE: For replacement parts use only manufacturer's specified parts.

Description	Quantity	Part No.
20. Primary Air Plate	1	MF201034
21. Screws for Primary Air Plate to Air Control Rod		
Hex/Washer Slot Machine Screw 10-32 X 1/4"	2	PH103214HWHSM
22. Air Control Rod	1	MF201035
23. Front Air Control Bracket	1	MF740017
24. Screws for Front Air Control Bracket to Stove		
Hex/Washer Self Drilling Screw 1/4-14 X 1"	2	PH14141TEKP
25. Top Baffle Board 1/2" X 9 1/2" X 19"	1	POBPFB01
26. Top Baffle Board 1/2" X 11" X 13 1/8"	1	POBPFB21
27. Font/Rear Air Secondary Tube	2	PS210026
28. Middle Air Secondary Tube	1	PS2100230
29. Rheostat-Opt. -Optional	1	PEBC204
30. Rheostat Knob -Optional	1	PEBC204A
31. Indicator Label -Optional	1	PEKB9724
32. Thermostat 110 disc -Optional	1	PE400132
33. Power Cord -Optional	1	PE400240
34. Strain Relief -Optional	1	PE400320
35. Blower Kit -Optional	1	MA5126715
36. Motor Only -Optional	1	PESBRO84
37. Close Clearance Shields -Optional	1	MA21SHIELD

NEW BUCK CORPORATION (NBC)
"LIMITED WARRANTY" FOR THE BUCK STOVE
PLEASE READ THIS WARRANTY CAREFULLY

PRODUCTS COVERED

This warranty covers the new Buck Stove heating unit, so long as it is owned by the original purchaser, including optional and standard accessories purchased at the same time, subject to terms, limitations and conditions herein set out.

PRODUCTS NOT COVERED

This warranty does not cover the following:
Glass, Refractory Material, Firebrick or Gaskets.

This Warranty will not cover any damage and/or failure caused by abuse or improper installation of the products covered.

WARRANTY TIME PERIODS

(A) Period I

For one year from the date of purchase, NBC will replace or repair, at its option, any part defective in materials or workmanship. The costs of parts only are included. The customer pays any labor or transportation charges required.

(B) Period II

Thereafter, for period after first year from date of purchase and extending for five years as long as Buck Stove is owned by the original purchaser, NBC will repair or replace, at its option, any part defective in materials or workmanship, with the exception of, electrical motors, wiring, switches, components, optional and standard accessories; and all parts not permanently attached to heating unit. Parts not permanently attached to heating unit are defined as those items designed to be removed from stove, including those removable with common hand tools. The costs of parts only are included. The customer pays any labor or transportation charges required.

PROCEDURE

Should you feel that your BUCK STOVE is defective, you should contact any Buck Stove dealer for the name of your nearest authorized Buck Stove service representative, who will instruct you on the proper procedure, depending on which Warranty Time Period (Period I or Period II) applies.

If for any reason you are dissatisfied with suggested procedures, you may contact us in writing at:

New Buck Corporation
Customer Service Department
P. O. Box 69
Spruce Pine, NC 28777
Email: info@buckstove.com

CONDITIONS AND EXCLUSIONS

- (A) Replacement of parts may be in the form of new or fully reconditioned parts, at NBC's option.
- (B) There is no other express warranty. All implied warranties of merchantability and fitness for use are limited to the duration of the Express Warranty.
- (C) New Buck Corporation is not liable for indirect, incidental or consequential damages in connection with use of product including any cost or expense of providing substitute equipment or service during periods of malfunction or non-use.
Some states do not allow the exclusion of incidental or consequential damages, so above exclusion may not apply to you.
- (D) All warranty repairs under this warranty must be performed by an authorized Buck Stove service representative. Repairs or attempted repairs by anyone other than an authorized service representative are not covered under this warranty. In addition, these unauthorized repairs may result in additional malfunctions, the correction of which is not covered by warranty.

OTHER RIGHTS

This warranty gives you specific legal rights, and you may also have other rights, which vary from state to state.

OWNER REGISTRATION CARD

The attached Owner Registration Card must be completed in its entirety and mailed within 30 days from the date of purchase or from the date of installation, if installed by a factory certified installer, to New Buck Corporation in order for warranty coverage to begin.

PLEASE NOTE: The Owner Registration Card must contain the Authorized Buck Stove Dealer Code Number and the Certified Installer's number (if applicable) for warranty coverage to begin.

To be completed by selling distributor/ dealer/ customer:

Name _____
(Last) (First)

Address _____

City _____ State _____ Zip _____

CUSTOMER EMAIL:: _____

MODEL 21 - Serial Number _____

Date of Installation: Day _____ Month _____ Year _____

Installer's Name _____

Installer's Certification Number _____

Dealer's Name _____

City _____ State _____ Zip _____