

Owner's Operation and Instruction Manual



BRECKWELL®

Exceptional Heat, Outstanding Value

MODELS: SW2100, SW3100

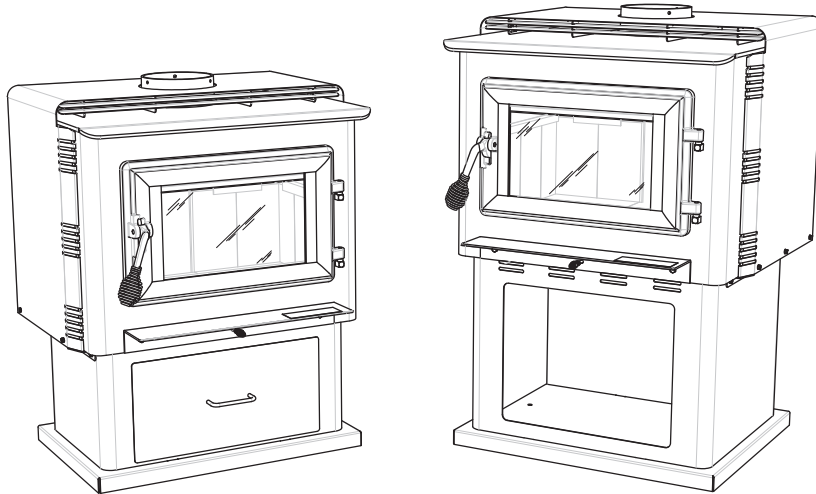

SAFETY TESTED TO UL 1482-2011 and ULC-S627-2000

US ENVIRONMENTAL PROTECTION AGENCY PHASE II CERTIFIED WOODSTOVE

WASHINGTON STATE APPROVED

MOBILE HOME APPROVED (U.S. ONLY)

CAUTION!

Please read this entire manual before you install or use your new room heater. Failure to follow instructions may result in property damage, bodily injury, or even death.

Improper Installation Could Void
Your Warranty!

SAFETY NOTICE:

If this heater is not properly installed, a house fire may result. For your safety, follow the installation instructions. Never use make-shift compromises during the installation of this heater. Contact local building or fire officials about permits, restrictions and installation requirements in your area.

SAVE THESE INSTRUCTIONS

THIS MANUAL WILL HELP YOU TO OBTAIN EFFICIENT, DEPENDABLE SERVICE FROM THE HEATER, AND ENABLE YOU TO ORDER REPAIR PARTS CORRECTLY. KEEP IN A SAFE PLACE FOR FUTURE REFERENCE.

French version is available for download from the U. S. Stove website: <http://www.Breckwell.com/>



United States Stove Company

227 Industrial Park Road
P.O. Box 151
South Pittsburg, TN 37380

TESTED &
LISTED BY



PORTLAND,
OREGON, USA

SW2100 Report #: 215-S-29c-4
SW3100 Report #: 215-S-23c-4

CONGRATULATIONS!

You've purchased a heater from North America's oldest manufacturer of wood burning products.

By heating with wood you're helping to CONSERVE ENERGY!

Wood is our only Renewable Energy Resource. Please do your part to preserve our wood supply. Plant at least one tree each year. Future generations will thank you.

The instructions pertaining to the installation of your wood stove comply with UL-1482-2011 and ULC-S627-2000 standards.

Combustible :	Model	Wood
Colors :		Metallic Black
Flue Pipe Diameter :		6" (15.3cm)
Flue Pipe Type: (Standard Single Wall or Double Wall):		Black or Blued Steel 2100°F (650°C)
Minimum Chimney Height :		12' (3.7m)
Maximum Log Length :		21" (53.4cm)
Dimensions		
Overall : Depth x Width x Height :	SW2100	23" x 27 1/4" x 34 1/8" (58cm x 69cm x 87cm)
	SW3100	27 1/2" x 27 1/4" x 40" (70cm x 69cm x 102cm)
Combustion Chamber : Width x Depth :	SW2100	22 3/4" x 12" (58cm x 30.5cm)
	SW3100	22 3/4" x 16 1/2" (58cm x 42cm)
Volume : Cubic Feet:	SW2100	1.86 ft³ (.0527m³)
	SW3100	2.69 ft³ (.0761m³)
Door Opening : Width x Height:		16" x 8" (41cm x 20cm)
Pyroceramic Door, Glass : (Viewing) Width x Height:		14 7/16" x 9 1/8" (37cm x 23cm x 5MM THK)
Weight (lbs):	SW2100	300 lbs (136kg)
	SW3100	350 lbs (159kg)

OPTIONAL ACCESSORIES	
DESCRIPTION	PART #
B36 Blower Assembly - 100 CFM	69354
Combustion Air Adapter	892021

CAUTIONS:

- HOT WHILE IN OPERATION. KEEP CHILDREN, CLOTHING AND FURNITURE AWAY. CONTACT MAY CAUSE SKIN BURNS.
- DO NOT USE CHEMICALS OR FLUIDS TO IGNITE THE FIRE.
- DO NOT LEAVE THE STOVE UNATTENDED WHEN THE DOOR IS SLIGHTLY OPENED.
- DO NOT BURN GARBAGE, FLAMMABLE FLUID SUCH AS GASOLINE, NAPHTHA OR MOTOR OIL.
- DO NOT CONNECT TO ANY AIR DISTRIBUTION DUCT OR SYSTEM.
- ALWAYS CLOSE THE DOOR AFTER THE IGNITION.

CUT HERE



WARRANTY INFORMATION CARD

Name _____ Telephone #: (____) _____

City _____ State _____ Zip _____

Email Address _____

Model # of Unit _____ Serial # _____

Fuel Type: Wood Coal Pellet Gas Other _____

Place of Purchase (Retailer) _____

City _____ State _____ Zip _____

If internet purchase, please list website address _____

Date of Purchase _____

Reason for Purchase: Alternative Heat Main Heat Source

Decoration Cost Other _____

What was the determining factor for purchasing your new appliance? _____

I have read the owner's manual that accompanies this unit and fully understand the:
Installation Operation and Maintenance of my new appliance.

Print Name Signature Date

Please attach a copy of your purchase receipt.

Warranty not valid without a Proof of Purchase.

Warranty information must be received within 30 days of original purchase.

Detach this page from this manual, fold in half with this page to the inside and tape together. Apply a stamp and mail to the address provided. You may use an envelope if you choose.

You may register online by going to www.usstove.com

All information submitted will be kept strictly confidential. Information provided will not be sold for advertising purposes.
Contact information will be used solely for the purpose of product notifications.

CUT HERE



CUT HERE



CUT HERE



Ussc

PLACE
STAMP
HERE

Fold Here



Fold Here



Three horizontal lines for an address label.

United States Stove Company
P.O. Box 151
South Pittsburg, TN 37380

Tools and Materials Needed For Installation

You will need a drill with a 1/8" bit to install sheet metal screws into connector pipe. A 5/16" socket/wrench or screw driver to install pedestal trim, room air deflector, and blower assembly described below. A 1/2" socket/wrench to install flue collar. A non-combustible floor protector as specified in this manual. All chimney and chimney connector components required for your particular chimney installation. For mobile homes, see page 13.

Assembly

Flue Collar Assembly:

1. Mount the flue collar to the top of the unit as shown using the (3) 5/16-18 x 1-1/2 bolts, (3) washers, and (3) weld tabs provided in the parts box.

Firebrick Configuration:

1. Replace the Firebrick as shown in the illustration below.

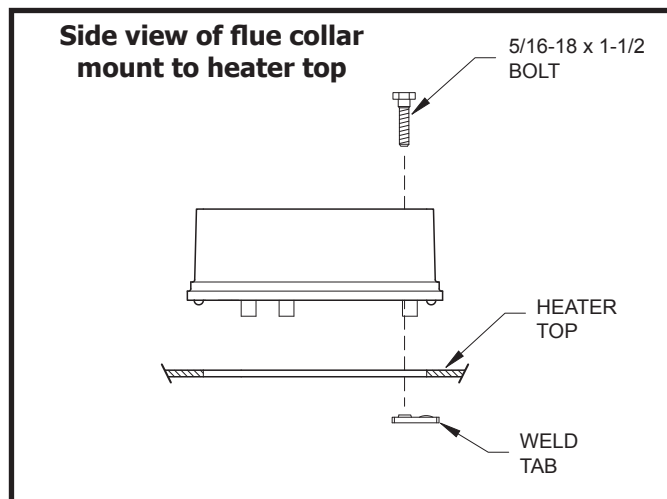

Brick Configuration

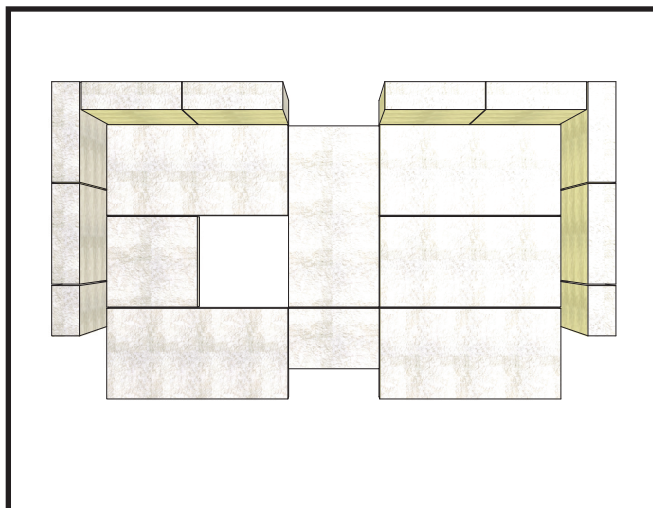

SW2100

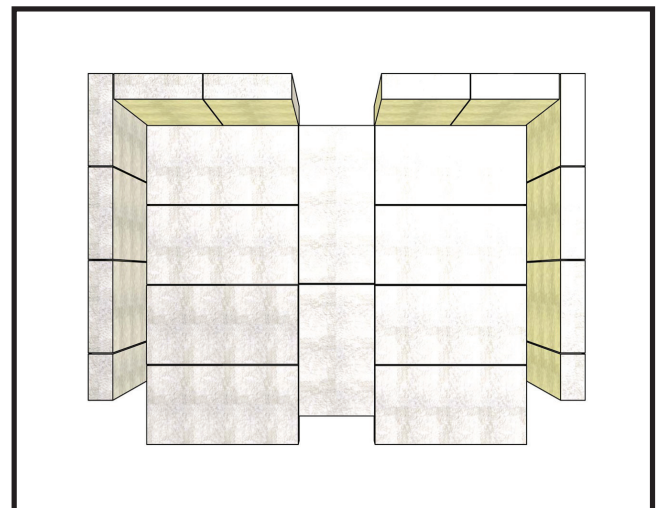

SW3100

ASSEMBLY INSTRUCTIONS

Combustion Air Intake

This appliance requires a source of combustion air. If your home is of tight construction, has negative pressure problems or is a mobile / manufactured home, you will need an outside source of air.

You have two options. You may cut a rectangular hole in the floor of your home and the floor protector, or purchase a standard 4" Dryer Vent kit from your local hardware supply store and install it on the rear of the pedestal.

If your choice is to cut a rectangular hole in the floor and flooring protector, refer to the below illustrations for assistance. You must place a rodent screen between the floor protector and the floor to prevent passage of any unwanted vermin into your home.

If using a Dryer venting kit, the outlet cover must be of a design that DOES NOT close by means of a flap or trap door. You must purchase a style that allows a continuous in-flow of air and that has a rodent screen. You will also need a Combustion Air Adapter to attach to the pedestal of the appliance. This adapter can be purchased from your dealer.

If your home is not of tight construction or not a manufactured mobile home, you can just simply remove the 4" round knockout in the rear of the pedestal.

❶ "Combustion Air thru Unit Base" installation:

First, decide the location of the appliance. Then, cut a 2" x 6" rectangular opening in the floor protector within the appliance base's perimeter. Using the flooring protector as a template, position it in place and mark onto the floor of your home where to make your next cut. Make the cut in your home's floor slightly larger than the 2" x 6" to accommodate any misalignment. Attach a piece of screen over the hole to prevent any unwanted vermin entering your home. Complete your appliance install.

❷ "Dryer Venting Kit" installation:

Begin by installing the 4" adapter to the rear of the appliance using the screws provided. If not already, remove the round knock-out from the pedestal. Follow the manufacturer's installation instructions for attaching the dryer vent kit to the home. Then attach it to the adapter on the appliance.

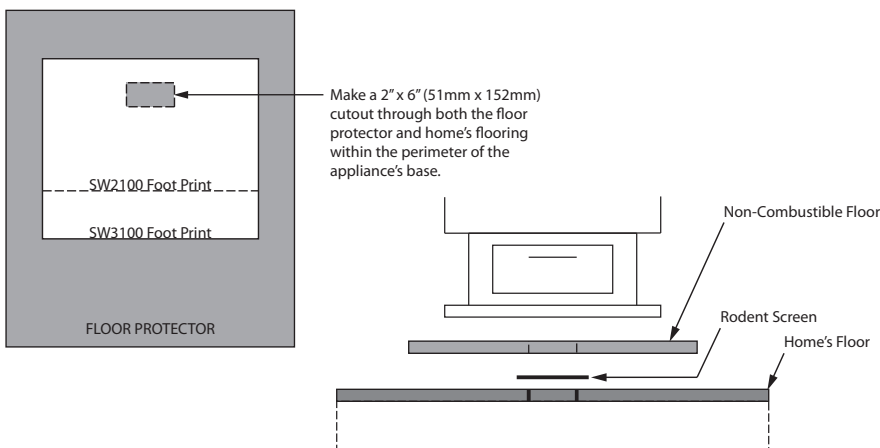

"Combustion Air thru Unit Base" Installation

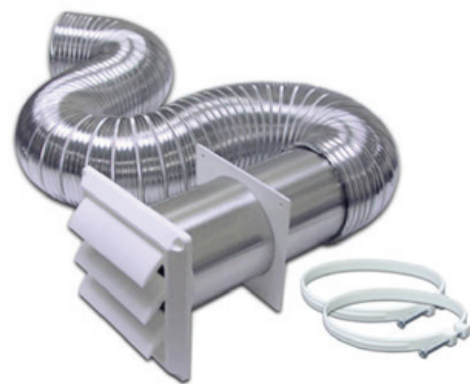

"Dryer Venting Kit" Installation

INSTALLATION

SAFETY NOTICE

- IF THIS STOVE IS NOT PROPERLY INSTALLED, A HOUSE FIRE MAY RESULT. TO REDUCE THE RISK OF FIRE, FOLLOW THE INSTALLATION INSTRUCTIONS.
- CONSULT YOUR MUNICIPAL BUILDING DEPARTMENT OR FIRE OFFICIALS ABOUT PERMITS, RESTRICTIONS AND INSTALLATIONS REQUIREMENTS IN YOUR AREA.
- USE SMOKE DETECTORS IN THE ROOM WHERE YOUR STOVE IS INSTALLED.
- KEEP FURNITURE AND DRAPES WELL AWAY FROM THE STOVE.
- NEVER USE GASOLINE, GASOLINE-TYPE LANTERN FUEL, KEROSENE, CHARCOAL LIGHTER FLUID, OR SIMILAR LIQUIDS TO START OR “FRESHEN UP” A FIRE IN THIS HEATER. KEEP ALL SUCH LIQUIDS WELL AWAY FROM THE HEATER WHILE IT IS IN USE.
- IN THE EVENT OF A CHIMNEY FIRE, PUSH THE AIR CONTROL FULL CLOSED TO DEPRIVE THE FIRE OF OXYGEN. CALL THE FIRE DEPARTMENT.
- DO NOT CONNECT TO ANY AIR DISTRIBUTION DUCT OR SYSTEM.
- A SOURCE OF FRESH AIR INTO THE ROOM OR SPACE HEATED SHALL BE PROVIDED WHEN REQUIRED.

POSITIONING THE STOVE

It is very important to position the wood stove as close as possible to the chimney, and in an area that will favor the most efficient heat distribution possible throughout the house. The stove must therefore be installed in the room where the most time is spent, and in the most spacious room possible. Recall that wood stoves produce radiating heat, the heat we feel when we are close to a wood stove. A wood stove also functions by convection, that is through the displacement of hot air accelerated upwards and its replacement with cooler air. If necessary, the hot air distribution from the stove may be facilitated by the installation of a blower.

The wood stove must not be hooked up to a hot air distribution system since an excessive accumulation of heat may occur.

A wood stove must never be installed in a hallway or near a staircase, since it may block the way in case of fire or fail to respect required clearances.

FLOOR PROTECTOR

Your wood stove should be placed on a 1 inch, non-combustible surface with a k factor of 0.84. For multiple layers, add R-values of each layer to determine the overall R-value. The R value for the required board is 1.2. If there is a horizontal section of chimney connector, the floor protector should go under it and 2 inches beyond each side

Convert specification to R-value:

k-factor is given with a required thickness (T) in inches: $R=1/k \times T$

C-factor is given: $R=1/C$

Example:

If the floor protector is 4" brick with a C-factor of 1.25 over 1/8" mineral board with a "k" factor of 0.29 the total R-value of the system is:

4" brick C=1.25, $R=1/1.25=0.8$

1/8" mineral board K=0.29, $R=1/0.29 \times 0.125=0.431$

Total R = $R_{brick} + R_{mineral} = 0.8 + 0.431 = 1.231$

Total R is greater than 1.2, the system is acceptable.

The floor protector should exceed the stove as follows:

The floor protector must be listed to UL1618

Model	Front	Sides	Rear
SW2100	25" (635mm)	8" (203mm)	☆6" (152mm)
SW3100	26" (660mm)	8" (203mm)	☆6" (152mm)

☆ - Canadian installations require 8" (203mm)

CLEARANCES TO COMBUSTIBLES

It is of utmost importance that the clearances to combustible materials be strictly adhered to during installation of the stove. Refer to the tables below :

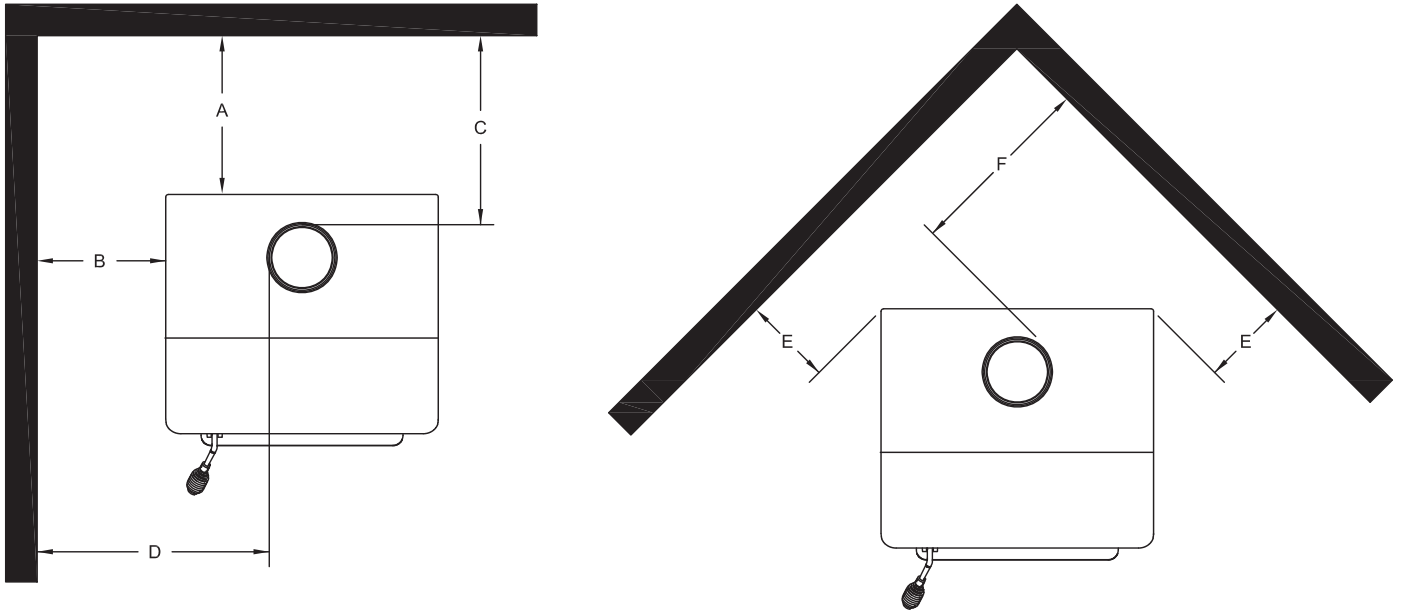

Single Wall Pipe (Double Wall Pipe)						
Model	A	B	C	D	E	F
SW2100	20(14) (508mm(356mm))	22(20) (559mm(508mm))	22.5(16.5) (572mm(419mm))	32(30) (813mm(762mm))	12(11) (305mm(279mm))	22(21) (559mm(533mm))
SW3100	12 (305mm)	20 (508mm)	16 (406mm)	30 (762mm)	10.5 (267mm)	20 (508mm)

- Floor to ceiling height must be at least 7' (2.13m) in all cases.
- Do not place any combustible material within 4' (1.2m) of the front of the unit.
- The clearance between the flue pipe and a wall are valid only for vertical walls and for vertical flue pipe.
- The chimney connector must not pass through an attic or roof space, closet or similar concealed space, a floor, or a ceiling.
- For Canadian installations, where passage through a wall, or partition of combustible construction is desired, the installation must conform to CAN/CSA-B365.
- A flue pipe crossing a combustible wall must have a minimum clearance of 18" (457.2mm).
- To reduce flue clearances from combustible materials, contact your local safety department.

CHIMNEY CONNECTOR (STOVE PIPE)

Your chimney connector and chimney must have the same diameter as the stove outlet (6"). If this is not the case, we recommend you contact your dealer in order to insure there will be no problem with the draft.

The stove pipe must be made of aluminized or cold roll steel with a minimum thickness of 0.021" or 0.53 mm. It is strictly forbidden to use galvanized steel.

Your smoke pipe should be assembled in such a way that the male section (crimped end) of the pipe faces down. Attach each of the sections to one another with three equidistant metal screws.

The pipe must be short and straight. All sections installed horizontally must slope at least 1/4 inch per foot, with the upper end of the section toward the chimney. Any installation with a horizontal run of chimney pipe must conform to NFPA 211. You may contact NFPA (National Fire Protection Association) and request the latest edition of the NFPA Standard 211.

To insure a good draft, the total length of the coupling pipe should never exceed 8' to 10' (2.4m to 3.04 m). (Except for cases of vertical installation, cathedral-roof style where the smoke exhaust system can be much longer and connected without problem to the chimney at the ceiling of the room).

There should never be more than two 90 degrees elbows in the smoke exhaust system.

Installation of a "barometric draft stabilizer" (fireplace register) on a smoke exhaust system is prohibited.

Furthermore, installation of a draft damper is not recommended. Indeed, with a controlled combustion wood stove, the draft is regulated upon intake of the combustion air in the stove and not at the exhaust.

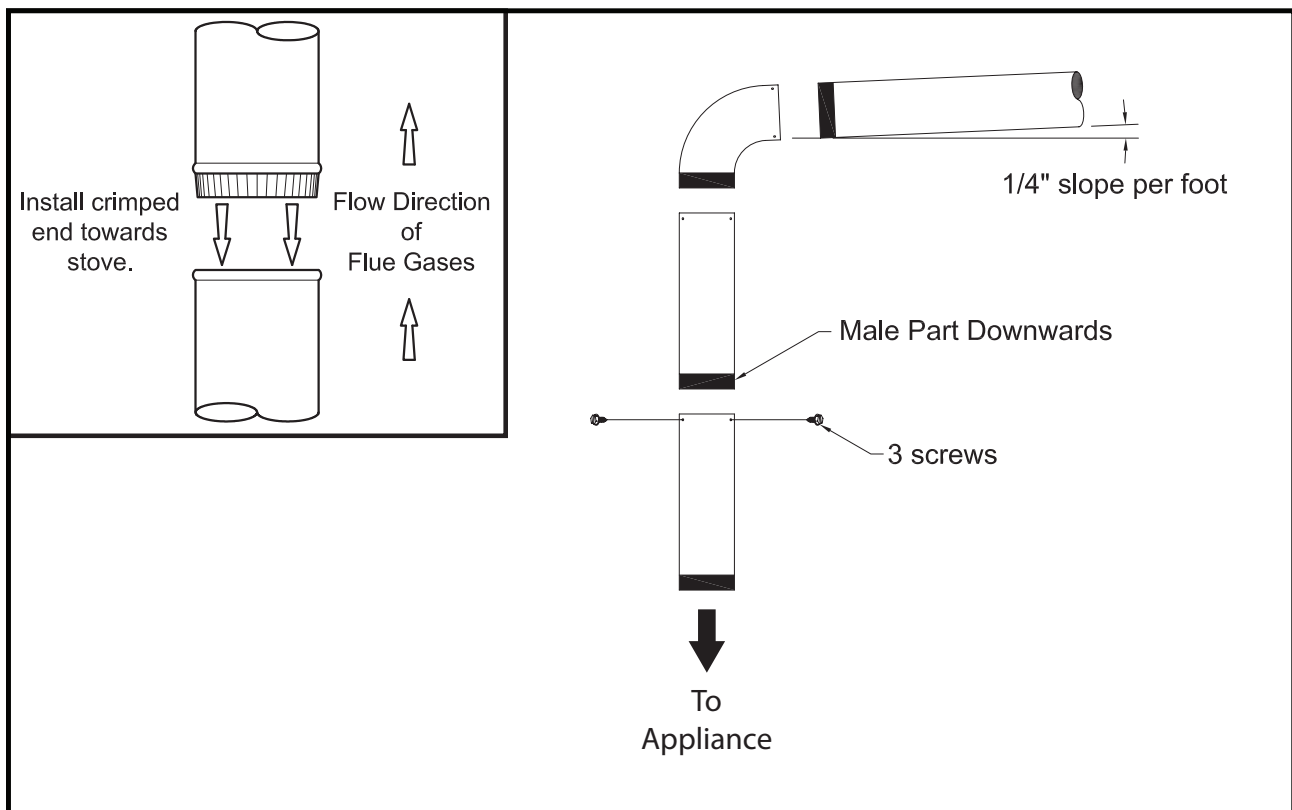

CHIMNEY

Your wood stove may be hooked up with a 6" factory built or masonry chimney. If you are using a factory built chimney, it must comply with UL 103 or CSA-B365 standard; therefore it must be a Type HT (2100°F). It is extremely important that it be installed according to the manufacturer's specifications.

If you are using a masonry chimney, it is important that it be built in compliance with the specifications of the National Building Code. It must be lined with fire clay bricks, metal or clay tiles sealed together with fire cement. (Round flues are the most efficient).

The interior diameter of the chimney flue must be identical to the stove smoke exhaust. A flue which is too small may cause draft problems, while a large flue favours rapid cooling of the gas, and hence the build-up of creosote and the risk of chimney fires. Note that it is the chimney and not the stove which creates the draft effect; your stove's performance is directly dependent on an adequate draft from your chimney.

The following recommendations may be useful for the installation of your chimney:

- 1. DO NOT CONNECT THIS UNIT TO A CHIMNEY FLUE SERVING ANOTHER APPLIANCE.**
- 2. It must rise above the roof at least 3' (0.9m) from the uppermost point of contact.**
- 3. The chimney must exceed any part of the building or other obstruction within a 10' (3.04m) distance by a height of 2' (0.6m).**
- 4. Installation of an interior chimney is always preferable to an exterior chimney. Indeed, the interior chimney will, by definition, be hotter than an exterior chimney, being heated up by the ambient air in the house. Therefore the gas which circulates will cool more slowly, thus reducing the build-up of creosote and the risk of chimney fires.**
- 5. The draft caused by the tendency for hot air to rise will be increased with an interior chimney.**
- 6. Using a fire screen at the extremity of the chimney requires regular inspection in order to insure that it is not obstructed thus blocking the draft, and it should be cleaned when used regularly.**

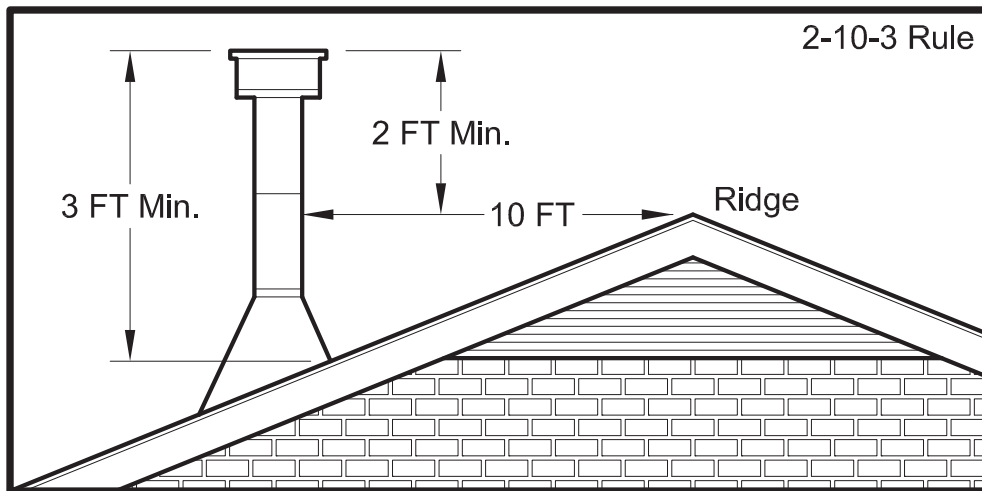

FACTORY BUILT CHIMNEY :

When a metal prefabricated chimney is used, the manufacturer's installation instructions must be followed. You must also purchase (from the same manufacturer) and install the ceiling support package or wall pass-through and "T" section package, firestops (where needed), insulation shield, roof flashing, chimney cap, etc. Maintain proper clearance to the structure as recommended by the manufacturer. The chimney must be the required height above the roof or other obstructions for safety and proper draft operation.

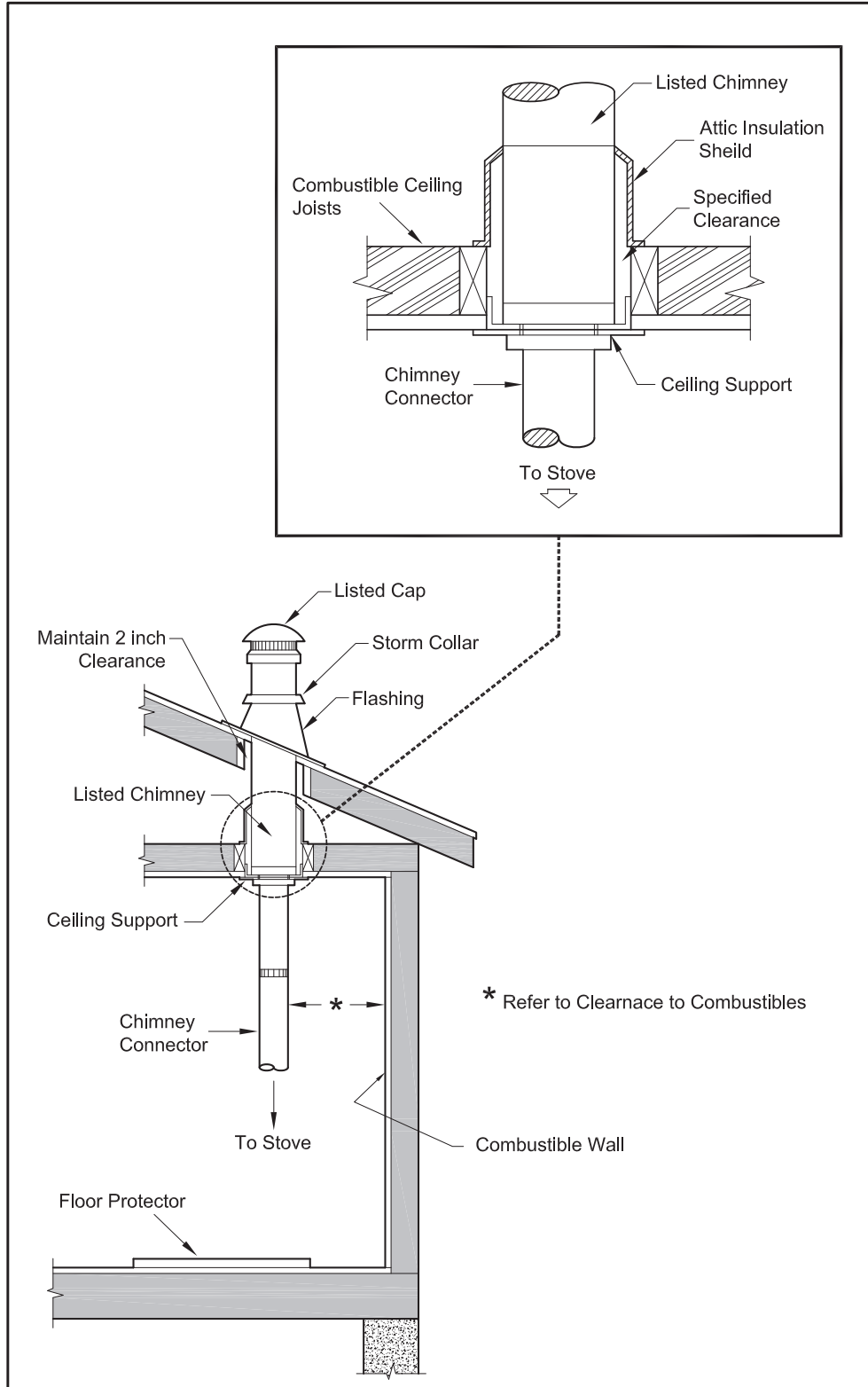

MASONRY CHIMNEY :

Ensure that a masonry chimney meets the minimum standards of the National Fire Protection Association (NFPA) by having it inspected by a professional. Make sure there are no cracks, loose mortar or other signs of deterioration and blockage. Have the chimney cleaned before the stove is installed and operated. When connecting the stove through a combustible wall to a masonry chimney, special methods are needed.

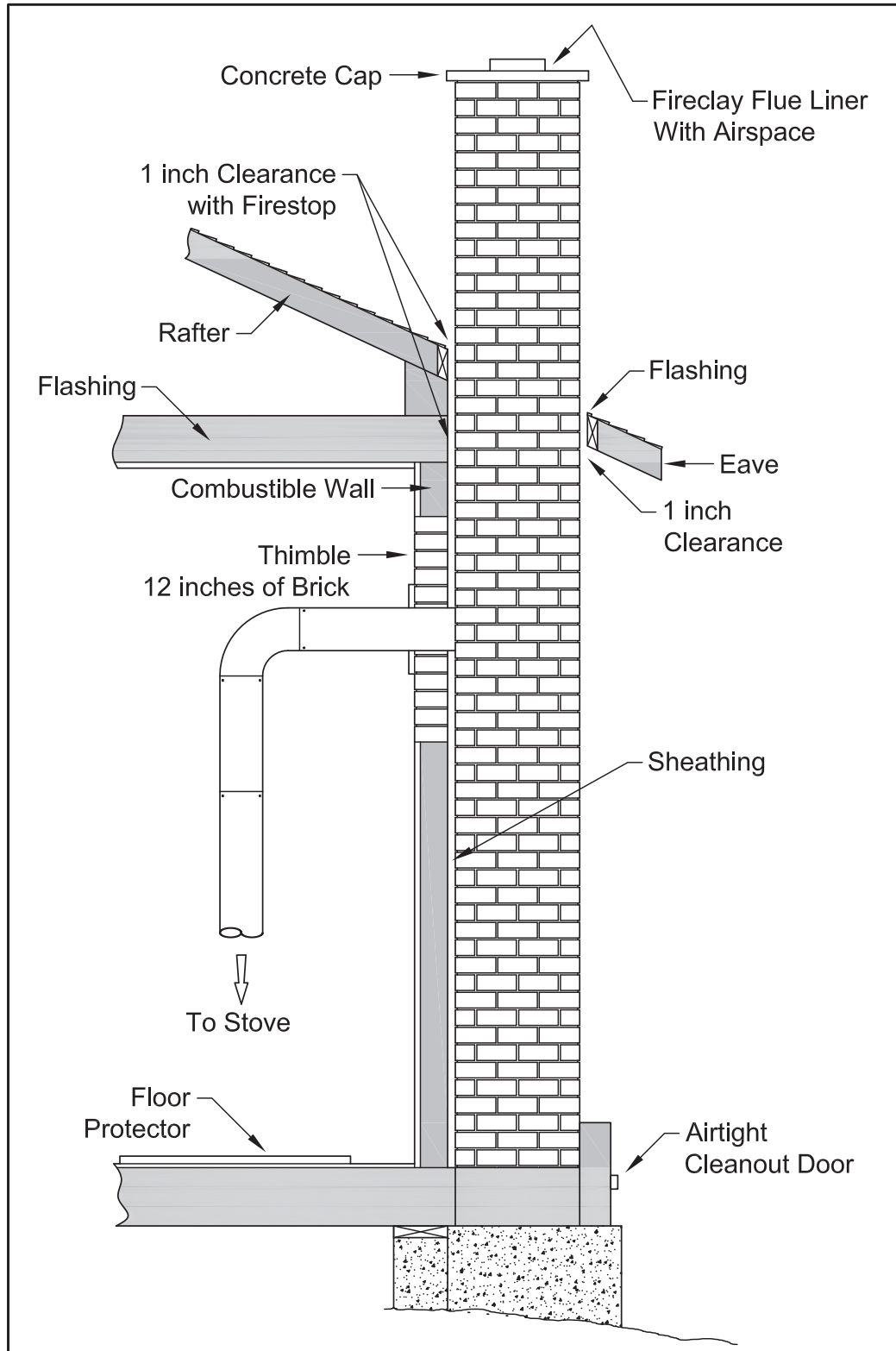

Combustible Wall Chimney Connector Pass-Throughs

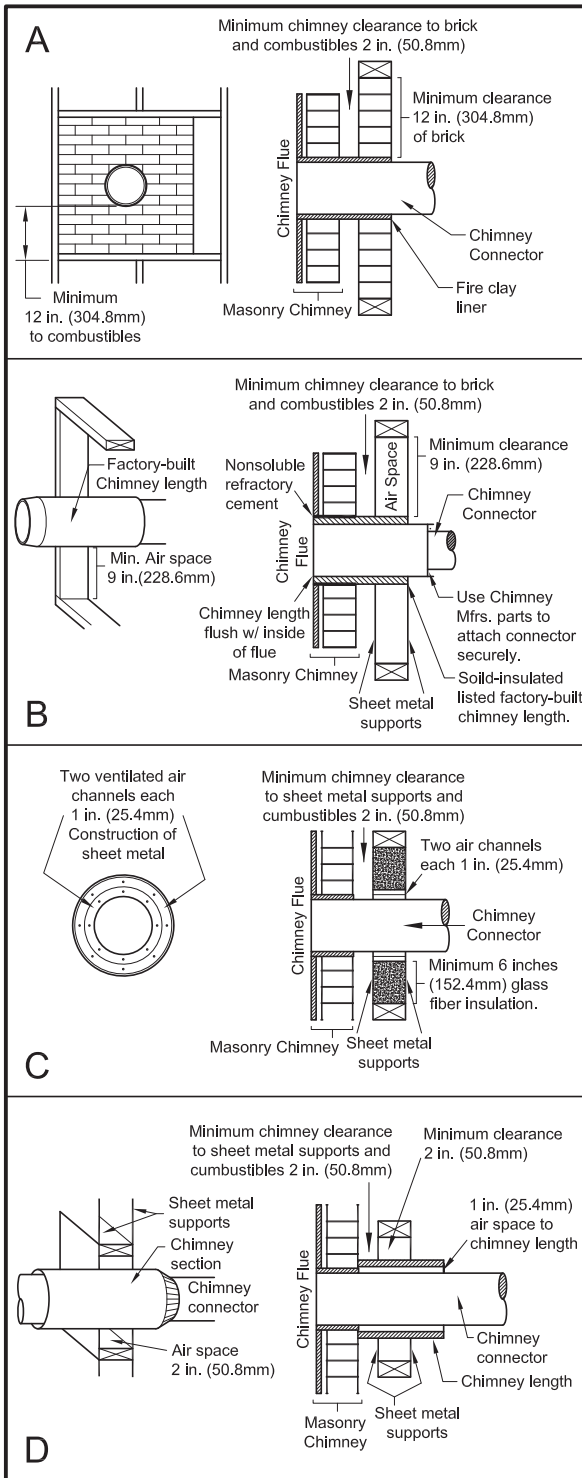

Method A. 12" (304.8 mm) Clearance to Combustible Wall Member: Using a minimum thickness 3.5" (89 mm) brick and a 5/8" (15.9 mm) minimum wall thickness clay liner, construct a wall pass-through. The clay liner must conform to ASTM C315 (Standard Specification for Clay Fire Linings) or its equivalent. Keep a minimum of 12" (304.8 mm) of brick masonry between the clay liner and wall combustibles. The clay liner shall run from the brick masonry outer surface to the inner surface of the chimney flue liner but not past the inner surface. Firmly grout or cement the clay liner in place to the chimney flue liner.

Method B. 9" (228.6 mm) Clearance to Combustible Wall Member: Using a 6" (152.4 mm) inside diameter, listed, factory-built Solid-Pak chimney section with insulation of 1" (25.4 mm) or more, build a wall pass-through with a minimum 9" (228.6 mm) air space between the outer wall of the chimney length and wall combustibles. Use sheet metal supports fastened securely to wall surfaces on all sides, to maintain the 9" (228.6 mm) air space. When fastening supports to chimney length, do not penetrate the chimney liner (the inside wall of the Solid-Pak chimney). The inner end of the Solid-Pak chimney section shall be flush with the inside of the masonry chimney flue, and sealed with a non-water soluble refractory cement. Use this cement to also seal to the brick masonry penetration.

Method C. 6" (152.4 mm) Clearance to Combustible Wall Member: Starting with a minimum 24 gage (.024" [.61 mm]) 6" (152.4 mm) metal chimney connector, and a minimum 24 gage ventilated wall thimble which has two air channels of 1" (25.4 mm) each, construct a wall pass-through. There shall be a minimum 6" (152.4 mm) separation area containing fiberglass insulation, from the outer surface of the wall thimble to wall combustibles. Support the wall thimble, and cover its opening with a 24-gage minimum sheet metal support. Maintain the 6" (152.4 mm) space. There should also be a support sized to fit and hold the metal chimney connector. See that the supports are fastened securely to wall surfaces on all sides. Make sure fasteners used to secure the metal chimney connector do not penetrate chimney flue liner.

Method D. 2" (50.8 mm) Clearance to Combustible Wall Member: Start with a solid-pak listed factory built chimney section at least 12" (304 mm) long, with insulation of 1" (25.4 mm) or more, and an inside diameter of 8" (2 inches [51 mm] larger than the 6" [152.4 mm] chimney connector). Use this as a pass-through for a minimum 24-gauge single wall steel chimney connector. Keep solid-pak section concentric with and spaced 1" (25.4 mm) off the chimney connector by way of sheet metal support plates at both ends of chimney section. Cover opening with and support chimney section on both sides with 24 gage minimum sheet metal supports. See that the supports are fastened securely to wall surfaces on all sides. Make sure fasteners used to secure chimney flue line.

NOTES:

1. Connectors to a masonry chimney, excepting method B, shall extend in one continuous section through the wall pass-through system and the chimney wall, to but not past the inner flue liner face.
2. A chimney connector shall not pass through an attic or roof space, closet or similar concealed space, or a floor, or ceiling.

OUTSIDE COMBUSTION AIR

For mobile home installations, your wood stove must have a fresh air intake installed. This type of installation is also required in air tight houses and houses with negative pressure problems. You can either purchase a dryer venting kit from your local hardware supply or cut a hole in the flooring protector and home's floor as shown in the illustration at the beginning of this manual.

Outside combustion air may be required if :

1. Your stove does not draw steadily, smoke rollout occurs, wood burns poorly, or back-drafts occur whether or not there is combustion present.
2. Existing fuel-fired equipment in the house, such as fireplaces or other heating appliances, smell, do not operate properly, suffer smoke roll-out when opened, or back-drafts occur whether or not there is combustion present.
3. Opening a window slightly on a calm (windless) day alleviates any of the above symptoms.
4. The house is equipped with a well-sealed vapor barrier and tight fitting windows and/or has any powered devices that exhaust house air.
5. There is excessive condensation on windows in the winter.
6. A ventilation system is installed in the house.

For use in MOBILE HOMES (U. S. installations ONLY):

- **WARNING! DO NOT INSTALL IN SLEEPING ROOM.**
- **CAUTION! THE STRUCTURAL INTEGRITY OF THE MOBILE HOME FLOOR, WALL, AND CEILING/ROOF MUST BE MAINTAINED.**
- INSTALL IN ACCORDANCE WITH 24 CFR, PART 3280 (HUD).
- USE A FACTORY BUILT CHIMNEY THAT COMPLIES WITH UL 103 STANDARDS; THEREFORE IT MUST BE A TYPE HT (2100°F).
- USE A SPARK ARRESTER.
- THE STOVE MUST BE ATTACHED TO THE STRUCTURE OF THE MOBILE HOME. USE THE TWO(2) HOLES IN THE BOTTOM OF THE HEATER'S PEDESTAL TO SECURE THE UNIT TO THE FLOOR.

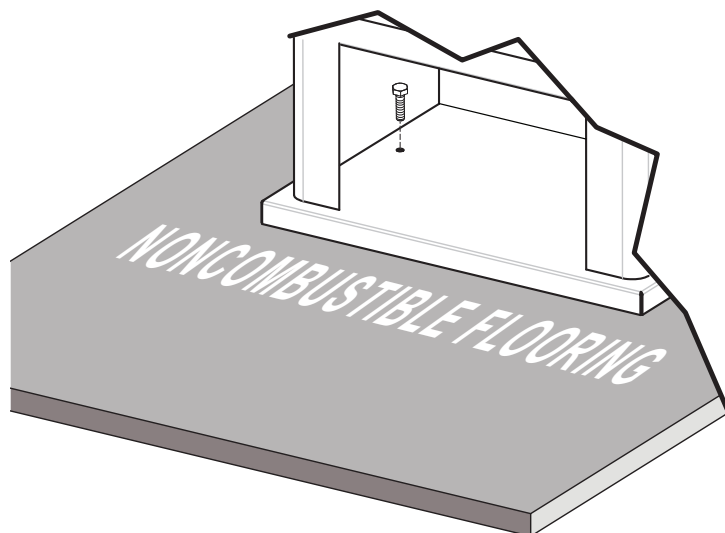

Illustration: Securing heater to the Floor.

WOODSTOVE UTILIZATION

Your heating unit was designed to burn wood only; no other materials should be burned. Waste and other flammable materials should not be burned in your stove. Any type of wood may be used in your stove, but specific varieties have better energy yields than others. Please consult the following table in order to make the best possible choice.

TYPE	WEIGHT (LBS. CU. FT., DRY)	PER CORD	EFFICIENCY RANKING	SPLITS	MILLIONS BTU's/CORD
Hickory	63	4500	1.0	Well	31.5
White Oak	48	4100	.9	Fair	28.6
Red Oak	46	3900	.8	Fair	27.4
Beech	45	3800	.7	Hard	26.8
Sugar Maple	44	3700	.6	Fair	26.2
Black Oak	43	3700	.6	Fair	25.6
Ash	42	3600	.5	Well	25.0
Yellow Birch	40	3400	.4	Hard	23.8
Red Maple	38	3200	.3	Fair	22.6
Paper Birch	37	3100	.3	Easy	22.1
Elm/Sycamore	34	2900	.2	Very Difficult	20.1
Red Spruce	29	1800	.1	Easy	16.1

It is EXTREMELY IMPORTANT that you use DRY WOOD only in your wood stove. The wood should have dried for 9 to 15 months, such that the humidity content (in weight) is reduced below 20% of the weight of the log. It is very important to keep in mind that even if the wood has been cut for one, two or even more years, it is not necessarily dry, if it has been stored in poor conditions. Under extreme conditions it may rot instead of drying. This point cannot be overstressed; the vast majority of the problems related to the operation of a wood stove is caused by the fact that the wood used was too damp or had dried in poor conditions. These problems can be:

- ignition problems
- creosote build-up causing chimney fires
- low energy yield
- blackened windows
- incomplete log combustion

Smaller pieces of wood will dry faster. All logs exceeding 6" in diameter should be split. The wood should not be stored directly on the ground. Air should circulate through the cord. A 24" to 48" air space should be left between each row of logs, which should be placed in the sunniest location possible. The upper layer of wood should be protected from the elements but not the sides.

TESTING YOUR WOOD

When the stove is thoroughly warmed, place one piece of split wood (about five inches in diameter) parallel to the door on the bed of red embers.

Keep the air control full open by pulling on it and close the door. If ignition of the piece is accomplished within 90 seconds from the time it was placed in the stove, your wood is correctly dried. If ignition takes longer, your wood is damp.

If your wood hisses and water or vapor escapes at the ends of the piece, your wood is soaked or freshly cut. Do not use this wood in your stove. Large amounts of creosote could be deposited in your chimney, creating potential conditions for a chimney fire.

THE FIRST FIRES

The fresh paint on your stove needs to be cured to preserve its quality. Once the fuel charge is properly ignited, only burn small fires in your stove for the first four hours of operation. Never open the air control more than necessary to achieve a medium burn rate.

Make sure that there's enough air circulation while curing the stove. The odors could be smelled during the 3 or 4 first fires. Never start your stove outside. You will not be able to see if you are over heating.

IGNITION

After making sure that the stove air intake controls are fully open (completely pull-out towards you), place several crumpled sheets of paper in the centre of the combustion chamber. Place 8 to 10 pieces of small dry kindling wood over the paper in the form of a tent. You may also place a few pieces of heating wood, but choose the smaller ones. No chemical product should be used to light the fire.

Before igniting the paper and kindling wood, it is recommended that you warm up the chimney. This is done in order to avoid back draft problems often due to negative pressure in the house. If such is the case, open a window slightly near the stove and twist together a few sheets of newspaper into a torch. Light up this paper torch and hold it as close as possible to the mouth of the pipe inside the combustion chamber to warm up the chimney. Once the updraft movement is initiated, you are ready to ignite the stove by lighting the paper and kindling wood inside the combustion chamber.

When you have achieved a good bed of hot embers, we recommend the following burn procedures:

SW2100			
Primary Air Settings		Electric Blower Speed Setting (Variable)	
(Slide Damper is located in center of stove under hearth plate) (Damper Adjustment: Pulling out on damper increases air)		(Blower is on High when turned "ON", Rotate clockwise until stop for "LOW".)	
Burn Rate	Adjust Damper from fully closed	Burn Time	Blower Speed
Low	1/4" (6.3mm)	@ 30 minutes	Low
Medium - Low	3/8" (9.5mm)	@ 30 minutes	Low
Medium - High	1/2" (12.7mm)	@ 30 minutes	Low
High	approx. 3" (76mm)	all minutes	High
SW3100			
Burn Rate	Adjust Damper from fully closed	Burn Time	Blower Speed
Low	1/32" (1mm)	@ 30 minutes	Low
Medium - Low	1/16" (1.5mm)	@ 30 minutes	Low
Medium - High	5/16" (8mm)	@ 30 minutes	Low
High	approx. 3" (76mm)	all minutes	High

CAUTION: Never alter the damper slide or the adjustment range to increase firing for any reason. Doing so could result in heater damage and will void your warranty.

HEATING

Controlled combustion is the most efficient technique for wood heating because it enables you to select the type of combustion you want for each given situation. The wood will burn slowly if the wood stove air intake control is adjusted to reduce the oxygen supply in the combustion chamber to a minimum. On the other hand, wood will burn quickly if the air control is adjusted to admit a larger quantity of oxygen in the combustion chamber. The air intake control on your stove is very simple. If you pull on it out completely towards you, it is fully open. If you push on it until it stops the combustion air is reduced to a minimum. Real operating conditions may give very different results than those obtained during testing according to the species of wood used, its moisture content, the size and density of the pieces, the length of the chimney, altitude and outside temperature.

WARNINGS

- NEVER OVERFIRE YOUR STOVE. IF ANY PART OF THE STOVE STARTS TO GLOW RED, OVER FIRING IS HAPPENING. READJUST THE AIR INTAKE CONTROL AT A LOWER SETTING.
- THE INSTALLATION OF A LOG CRADLE or GRATES IS NOT RECOMMENDED IN YOUR WOOD STOVE. BUILD FIRE DIRECTLY ON FIREBRICK.
- NEVER PUT WOOD ABOVE THE FIREBRICK LINING OF THE FIREBOX.

RELOADING

Once you have obtained a good bed of embers, you should reload the unit. In order to do so, open the air controls to maximum a few seconds prior to opening the stove's door. Then proceed by opening the door very slowly; open it one or two inches for 5 to 10 seconds, before opening it completely to increase the draft and thus eliminate the smoke which is stagnant in a state of slow combustion in the stove. Then bring the red embers to the front of the stove and reload the unit.

For optimal operation of your wood stove, we recommend you to operate it with a wood load approximately equivalent to the height of fire bricks.

It is important to note that wood combustion consumes ambient oxygen in the room. In the case of negative pressure, it is a good idea to allow fresh air in the room, either by opening a window slightly or by installing a fresh air intake system on an outside wall.

Creosote - Formation and Need for Removal - When wood is burned slowly, it produces tar and other organic vapors, which combine with expelled moisture to form creosote. The creosote vapors condense in the relatively cool chimney flue of a slow-burning fire. As a result, creosote residue accumulates on the flue lining. When ignited this creosote makes an extremely hot fire. The chimney connector and chimney should be inspected at least once every two months during the heating season to determine if a creosote build-up has occurred. If creosote has accumulated (3mm or more), it should be removed to reduce the risk of a chimney fire.

We strongly recommend that you install a magnetic thermometer on your smoke exhaust pipe, approximately 18" above the stove. This thermometer will indicate the temperature of your gas exhaust fumes within the smoke exhaust system. The ideal temperature for these gases is somewhere between 275°F and 500°F. Below these temperatures, the build-up of creosote is promoted. Above 500 degrees, heat is wasted since a too large quantity is lost into the atmosphere.

TO PREVENT CREOSOTE BUILD UP

- Always burn dry wood. This allows clean burns and higher chimney temperatures, therefore less creosote deposit.
- Leave the air control full open for about 5 min. every time you reload the stove to bring it back to proper operating temperatures. The secondary combustion can only take place if the firebox is hot enough.
- Always check for creosote deposit once every two months and have your chimney cleaned at least once a year.

If a chimney or creosote fire occurs, close all dampers immediately. Wait for the fire to go out and the heater to cool, then inspect the chimney for damage. If no damage results, perform a chimney cleaning to ensure there is no more creosote deposits remaining in the chimney.

ASH DISPOSAL

Ashes should be removed from the stove every few days or when ashes get to 2 to 3 inches deep. Always empty the stove when it is cold, such as in the morning. Ashes should be placed in a steel container with a tight fitting lid. The closed container of ashes should be placed on a non combustible floor or on the ground, well away from all combustible materials, pending final disposal. If the ashes are disposed of by burial in soil or otherwise locally dispersed, they should be retained in the close container until all cinders have thoroughly cooled. Other waste shall not be placed in this container.

CAUTIONS:

- **ASHES COULD CONTAIN HOT EMBERS EVEN AFTER TWO DAYS WITHOUT OPERATING THE STOVE.**
- **THE ASH PAN CAN BECOME VERY HOT. WEAR GLOVES TO PREVENT INJURY.**
- **NEVER BURN THE STOVE WITH THE ASH TRAP OPEN. THIS WOULD RESULT IN OVER FIRING THE STOVE. DAMAGE TO THE STOVE AND EVEN HOUSE FIRE MAY RESULT.**

MAINTENANCE

Your wood stove is a high efficiency stove and therefore requires little maintenance. It is important to perform a visual inspection of the stove every time it is emptied, in order to insure that no parts have been damaged, in which case repairs must be performed immediately. Inspect and clean the chimney and connector pipe periodically for creosote buildup or obstructions.

GLASS

- Inspect and clean the glass regularly in order to detect any cracks. If you spot one, turn the stove off immediately. Do not abuse the glass door by striking or slamming shut. Do not use the stove if the glass is broken.
- **If the glass on your stove breaks, replace only with the glass supplied from your heater dealer. Never substitute other materials for the glass.**
- To replace the glass, remove the screws retaining the glass mouldings inside the door. Remove the mouldings and replace the damaged piece with a new one. Perform the procedure backwards after replacing. When replacing the glass, you should change the glass gasket to make sure you keep it sealed.
- Never wash the glass with a product that may scratch. Use a specialized product, available in the stores where wood stoves are sold. The glass should be washed only when cold.

GASKETING

It is recommended that you change the door gasket (which makes your stove door air tight) once a year, in order to insure good control over the combustion, maximum efficiency and security. To change the door gasket, simply remove the damaged one. Carefully clean the available gasket groove, apply a high temperature silicone sold for this purpose, and install the new gasket. You may light up your stove again approximately 24 hours after having completed this operation.

WARNING:

- **NEVER OPERATE THE STOVE WITHOUT A GASKET OR WITH A BROKEN ONE. DAMAGE TO THE STOVE OR EVEN HOUSE FIRE MAY RESULT.**

PAINT

Only clean your stove with a dry soft cloth that will not harm the paint finish. If the paint becomes scratched or damaged, it is possible to give your wood stove a brand new look, by repainting it with a 1200° F heat resistant paint. For this purpose, simply scrub the surface to be repainted with fine sand paper, clean it properly, and apply thin coats (2) of paint successively.

REPAIR PARTS (SW2100)

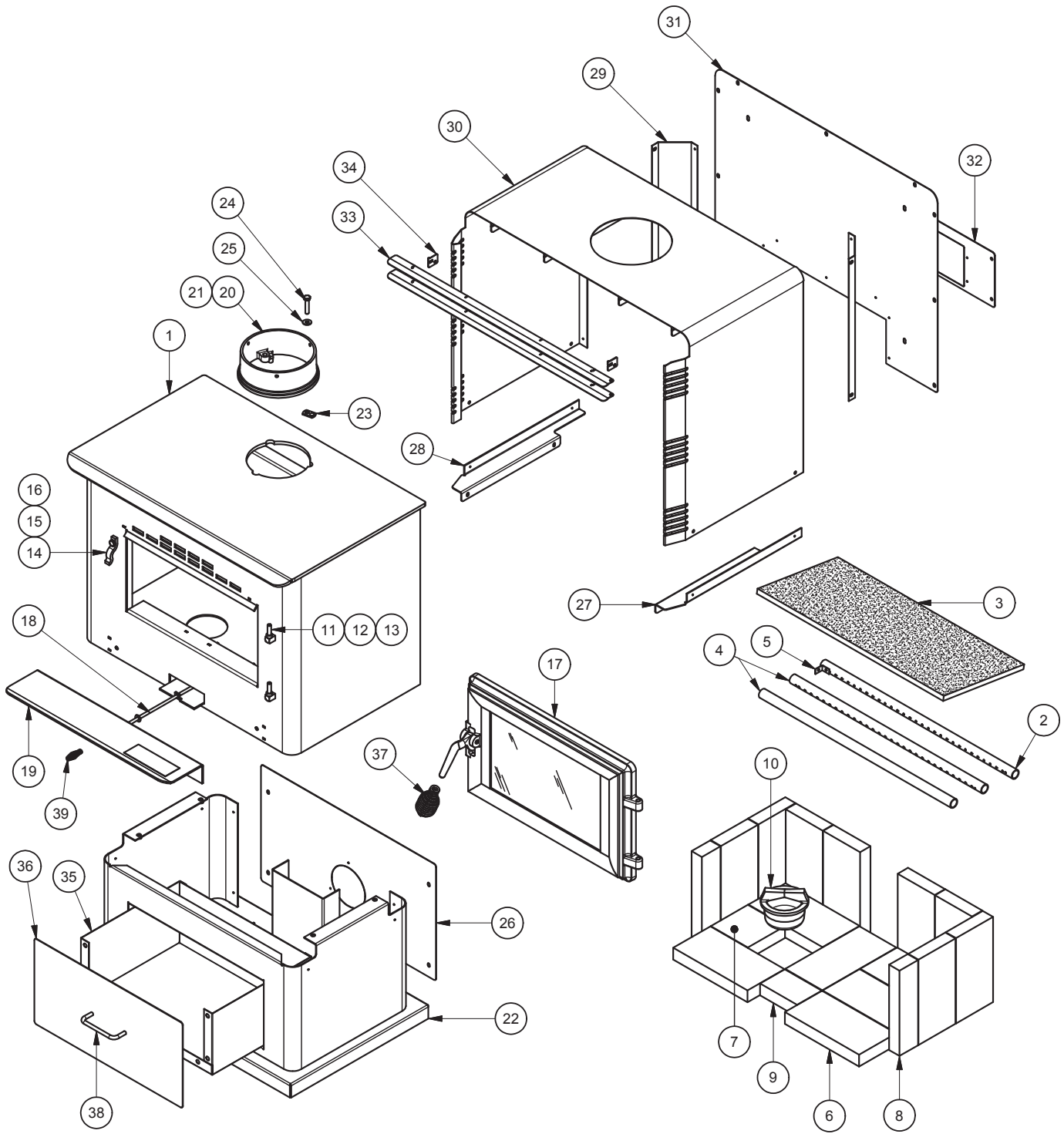

REPAIR PARTS LIST (SW2100)

Key	Part No.	Description	Qty.
1	891749	Weld., Main Body	1
2	86643	Tube (Ø5/32) . Secondary Air	1
3	88146	Board, Ceramic Fiber	1
4	86645	Tube (Ø7/32) . Secondary Air	2
5	891515	Retainer, Tube	3
6	89066	Brick (9 x 4.5)	14
7	24103	Brick, Half (4.5 x 4.5)	1
8	891414	Brick, Half (9 x 2.25)	2
9	891783	Brick (3 x 4.5)	1
10	40561	Ash Plug	1
11	891373	Pad, Door Hinge (Threaded)	2
12	83045A	Washer, 3/8"ID x 7/8"OD x 1/16"THK	2
13	83274	3/8-16 LK Nut Black	2
14	25080	Latch, Door	1
15	83508	5/16-18 x 3/4 Bolt	1
16	83338	5/16-18 Lock Nut	1
17	69660	Assembly, Door_Large Rectangle	1
18	891516	Weld., Damper Slide	1
19	892020	Plate, Hearth	1
20	40292A	6" Flue Collar	1

Key	Part No.	Description	Qty.
21	88042	1/4" Rope Gasket	1
22	69665	Assembly, Pedestal	1
23	83431	Weld Tab	3
24	83432	5/16-18 x 1-1/2 Bolt	3
25	83045	Washer, 5/16"ID x 3/4"OD x 1/16"THK	3
26	892031	Back, Pedestal	1
27	892024	R-Mounting BRKT, Shroud	1
28	892025	L-Mounting BRKT, Shroud	1
29	892009	Shroud Mount, Rear	2
30	69704	Weldment, Shroud	1
31	892008	Rear, Shroud Panel	1
32	892015	Plate, Blower Adaopter	1
33	892013	Louver	2
34	892014	Retainer, Louver	2
35	892032	Body, Ash Pan	1
36	892033	Front, Ash Pan	1
37	891135	Handle, Spring (LG-Nickel)	1
38	891137	Handle, Brushed Nickel	1
39	891331	Spring Handle-Brushed Nickel	1

REPAIR PARTS (SW3100)

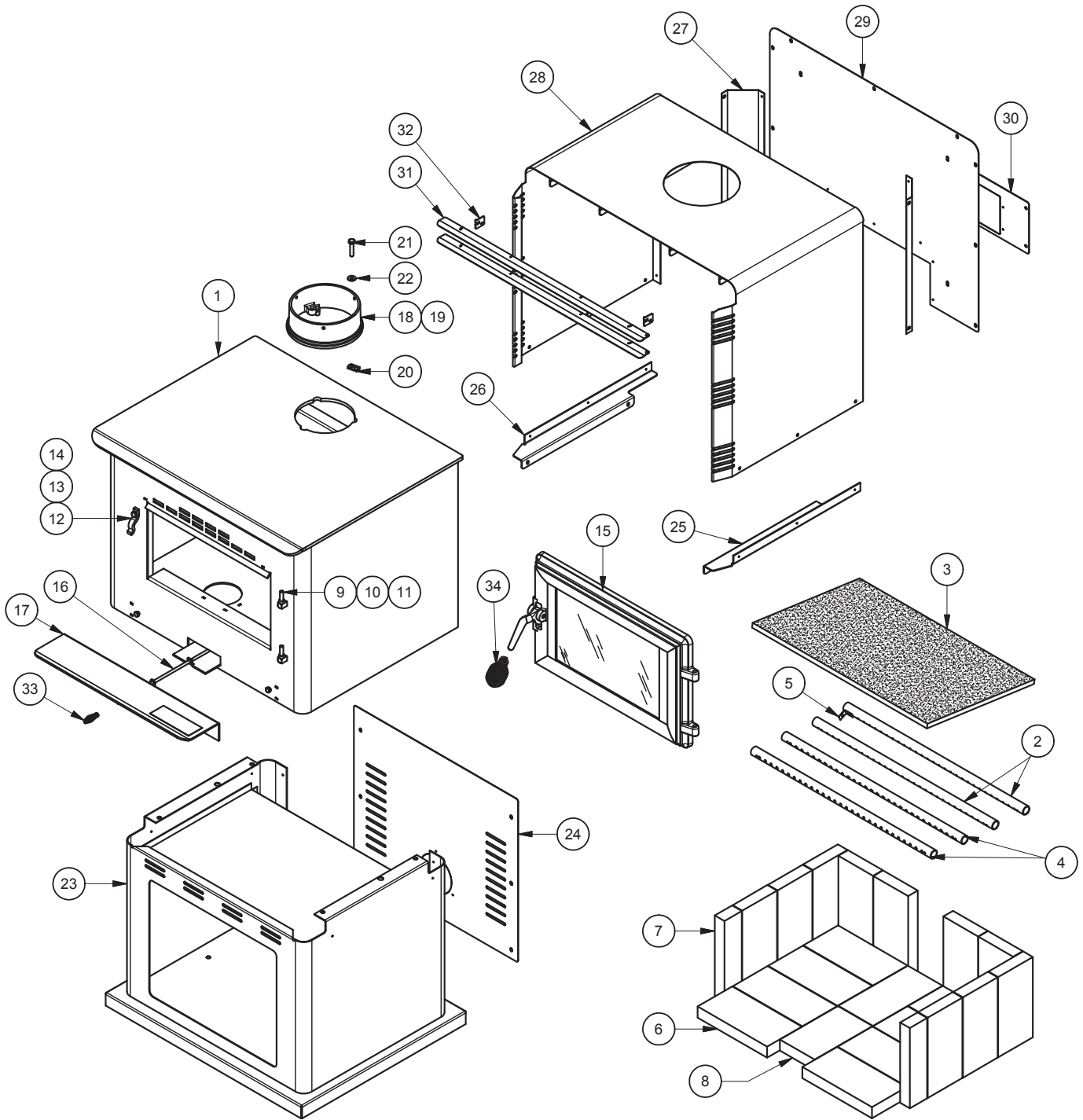

REPAIR PARTS LIST (SW3100)

Key	Part No.	Description	Qty.
1	891529	Weld., Main Body	1
2	86643	Tube (Ø5/32) . Secondary Air	2
3	88138	Board, Ceramic Fiber	1
4	86645	Tube (Ø7/32) . Secondary Air	2
5	891515	Retainer, Tube	4
6	89066	Brick (9 x 4.5)	19
7	891414	Brick, Half (9 x 2.25)	1
8	891530	Brick (4.5 x 7.5 x 1.25)	1
9	891373	Pad, Door Hinge (Threaded)	1
10	83045A	Washer, 3/8"ID x 7/8"OD x 1/16"THK	2
11	83274	3/8-16 LK Nut Black	2
12	25080	Latch, Door	1
13	83508	5/16-18 x 3/4 Bolt	1
14	83338	5/16-18 Lock Nut	1
15	69660	Assembly, Door_Large Rectangle	1
16	891516	Weld., Damper Slide	1
17	892020	Plate, Hearth	1

Key	Part No.	Description	Qty.
18	40292A	6" Flue Collar	1
19	88042	1/4" Rope Gasket	1
20	83431	Weld Tab	3
21	83432	5/16-18 x 1-1/2 Bolt	3
22	83045	Washer, 5/16"ID x 3/4"OD x 1/16"THK	3
23	69665	Assembly, Pedestal	1
24	892019	Back, Pedestal	1
25	892010	R-Mounting BRKT, Shroud	1
26	892011	L-Mounting BRKT, Shroud	1
27	892009	Shroud Mount, Rear	2
28	69705	Weldment, Shroud	1
29	892008	Rear, Shroud Panel	1
30	892015	Plate, Blower Adapter	1
31	892013	Louver	2
32	892014	Retainer, Louver	2
33	891331	Spring Handle-Brushed Nickel	1
34	891135	Handle, Spring (LG-Nickel)	1

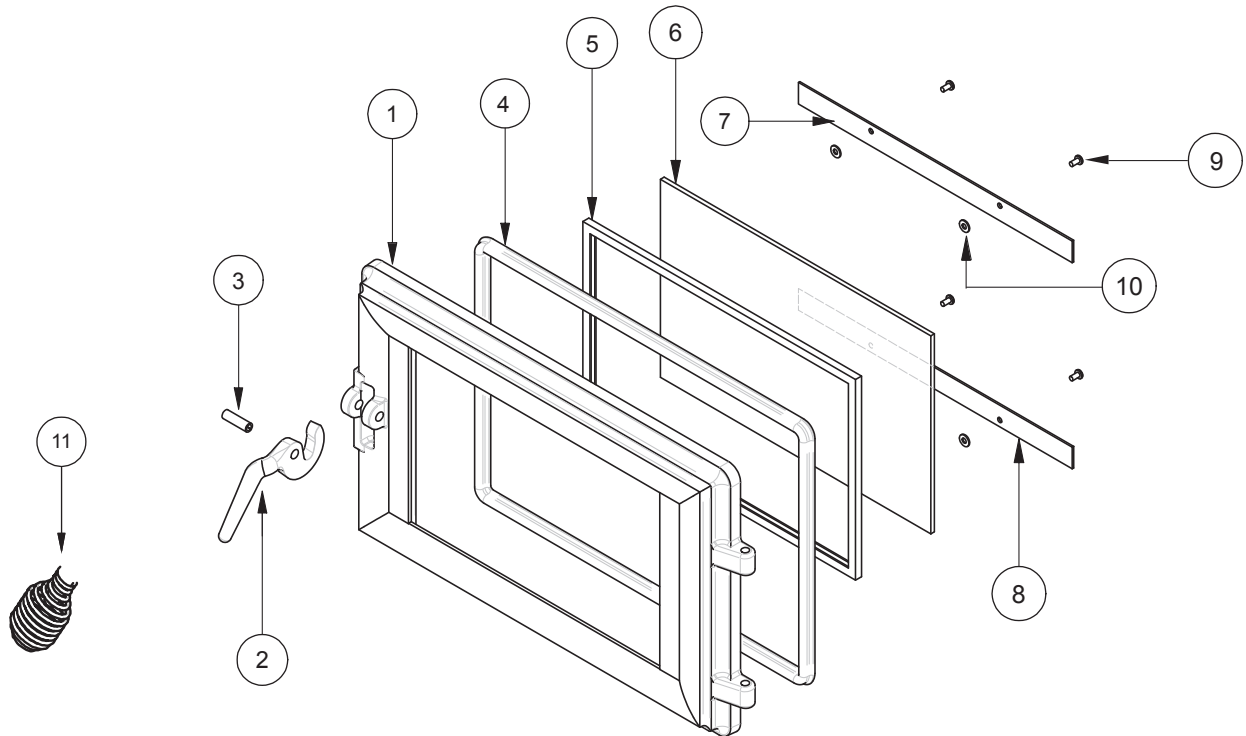

Parts List	Key	Part No.	Description	Qty.	Key	Part No.	Description	Qty.
	1	25780	Feed Door	1	7	25465	Retainer, Bottom Glass	2
	2	25492	Handle, Door	1	8			
	3	83506	Roll Pin, 3/8 x 1-1/4	1	9	83202	Machine Screw	4
	4	88112	Gasket, 1/2" Sq. Rope	5 ft	10	83278	#10 Flat Washer	4
	5	88087	Gasket, Glass (1x3/16)	4 ft	11	891135	Handle, Spring (Parts Bag)	4
	6	891813	Glass Ceramic (5mm THK, 9-1/8" x 14-7/16")	1				

HOW TO ORDER REPAIR PARTS

THIS MANUAL WILL HELP YOU OBTAIN EFFICIENT, DEPENDABLE SERVICE FROM YOUR HEATER, AND ENABLE YOU TO ORDER REPAIR PARTS CORRECTLY.

KEEP THIS MANUAL IN A SAFE PLACE FOR FUTURE REFERENCE.

WHEN WRITING, ALWAYS GIVE THE FULL MODEL NUMBER WHICH IS ON THE NAMEPLATE ATTACHED TO THE HEATER.

WHEN ORDERING REPAIR PARTS, ALWAYS GIVE THE FOLLOWING INFORMATION AS SHOWN IN THIS LIST:

1. THE PART NUMBER
2. THE PART DESCRIPTION
3. THE MODEL NUMBER: _____
4. THE SERIAL NUMBER: _____

US Stove Company
227 Industrial Park Road
P.O. Box 151
South Pittsburg, TN 37380
Phone: (800) 750-2723
Web: www.BRECKWELL.com