

Owner's Instruction and Operation Manual

Ashley
America's Hearth Since 1905

Model Number:

**CAC/BCAC
COAL ONLY STOVE**



Report #: F20-574

This unit was tested and listed to UL 1482-1996.
DO NOT USE THIS HEATER IN A MOBILE
HOME OR TRAILER

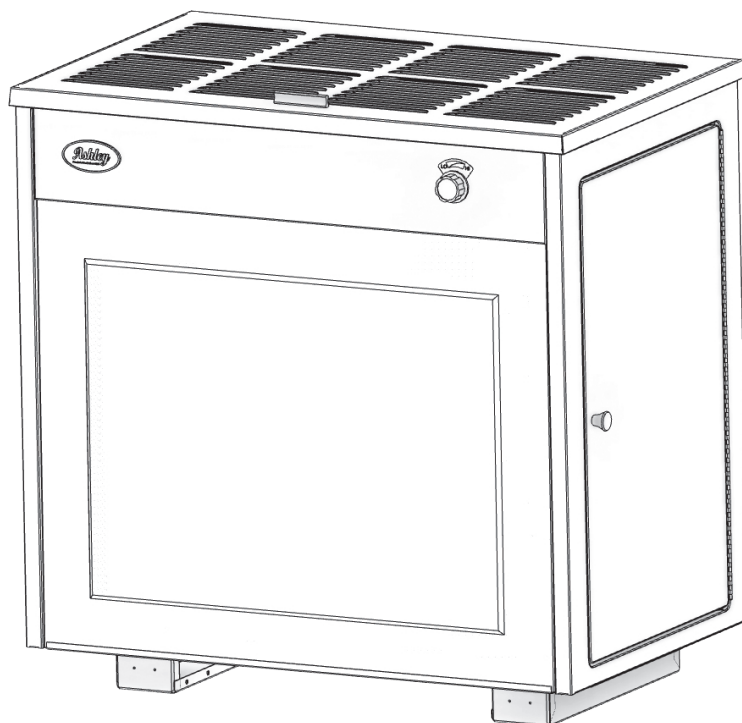

* All Pictures In This Manual Are For Illustrative Purposes Only. Actual Product May Vary.

851396K-0102K

Save These Instructions In A Safe Place For Future Reference.



SAFETY NOTICE: If this heater is not properly installed, a house fire may result. For your safety, follow the installation instructions. Never use make-shift compromises during the installation of this heater. Contact local building or fire officials about permits, restrictions and installation requirements in your area. **NEVER OPERATE THIS PRODUCT WHILE UNATTENDED.**



CAUTION! Please read this entire manual before you install or use your new room heater. Failure to follow instructions may result in property damage, bodily injury, or even death. Improper Installation Will Void Your Warranty!



CALIFORNIA PROPOSITION 65 WARNING:

This product can expose you to chemicals including carbon monoxide, which is known to the State of California to cause cancer, birth defects, and/or other reproductive harm. For more information, go to www.P65warnings.ca.gov

THIS MANUAL IS SUBJECT TO CHANGE WITHOUT NOTICE.

Combustible:	Coal
Colors:	Black
Flue Pipe Diameter:	6" (153 mm)
Flue Pipe Type:	Black or Blued Steel 2100°F (650°C)
Minimum Chimney Height:	12' (3.7 m)
Dimensions	
Overall: Depth x Width x Height:	22-3/16" (564 mm) X 33-11/16" (856 mm) X 34-3/16" (868 mm)
Combustion Chamber: Width x Depth:	22-1/8" (563 mm) X 13" (331 mm)
Door Opening: Width x Height:	10" (254 mm) X 13-1/5" (343 mm)

CAUTIONS:

- **HOT WHILE IN OPERATION. KEEP CHILDREN, CLOTHING AND FURNITURE AWAY. CONTACT MAY CAUSE SKIN BURNS.**
- **DO NOT USE CHEMICALS OR FLUIDS TO IGNITE THE FIRE.**
- **DO NOT LEAVE THE STOVE UNATTENDED WHEN THE DOOR IS SLIGHTLY OPENED.**
- **DO NOT BURN GARBAGE, FLAMMABLE FLUID SUCH AS GASOLINE, NAPHTHA OR MOTOR OIL.**
- **DO NOT CONNECT TO ANY AIR DISTRIBUTION DUCT OR SYSTEM.**
- **ALWAYS CLOSE THE DOOR AFTER THE IGNITION.**
- **YOUR CHIMNEY MUST BE INSPECTED PRIOR TO THE INSTALLATION OF YOUR NEW COAL STOVE. IN ADDITION, YOU SHOULD HAVE YOUR CHIMNEY INSPECTED FOR CREOSOTE DEPOSITS MONTHLY DURING THE HEATING SEASON AND ANNUALLY INSPECTED AND CLEANED.**



Note: Register your product online at www.usstove.com or download the free app today. This app is available only on the App Store for iPhone and iPad. Search US Stove. Save your receipt with your records for any claims.

For Customer Service, please call:

1-800-750-2723 Ext 5050 or;

Text to 423-301-5624 or;

Email us at:

customerservice@usstove.com

INSTALLATION CHECKLIST



Your coal stove should be installed by a qualified installer only. An NFI qualified Installer can be found at www.nficertified.org/public/find-an-nfi-pro/

CUSTOMER SERVICE

1-800-750-2723 ext 5050
Text to 423-301-5624
Email to: Customerservice@usstove.com

COMMISSIONING CHECKLIST

This Checklist is to be completed in full by the qualified person who installs this unit. Keep this page for future reference.

Failure to install and commission according to the manufacturer's instructions and complete this checklist will invalidate the warranty.

Please Print

Customer Name:	Telephone Number:
Address:	
Model:	
Serial Number:	
Installation Company Name:	Phone Number:
Installation Technician's Name:	License Number:

DESCRIPTION OF WORK

Location of installed appliance: _____

Venting System: New Venting System Yes No If yes, Brand _____

If no, Date of inspection of existing venting system: _____

COMMISSIONING

- Confirm Hearth Pad Installation as per Installation Instructions.....
- Confirm proper placement of internal parts
- Check soundness of door gasket and door seals
- Confirm clearances to combustibles as per installation instructions in this manual
- Check the operations of the air controls
- Confirm the venting system is secure and sealed.....
- Confirm the stove starts and operates properly.....
- Check to ensure a CO alarm is installed as per local building codes and is functional
- Explain the safe operation, proper fuel usage, cleaning, and routine maintenance requirements

Declaration of Completion: As the qualified person responsible for the work described above, I confirm that the appliance as associated work has been installed as per manufacturer's instructions and following any applicable building and installation codes.

Signed: _____ Print Name: _____ Date: _____

Home Owner: RETAIN THIS INFORMATION FOR FUTURE REFERENCE

To assure that satisfactory and safe service is received from this heater:

- Read these instructions entirely before beginning any part of the installation.
- Use these instructions as a guide during the installation of the heater.
- Be sure these instructions become the property of and are reviewed by all future users of this heater to encourage proper operation and maintenance of this appliance.

THIS HEATER IS ONLY FOR BURNING COAL. USE OF ANY OTHER SOLID FUEL EXCEPT FOR COAL IGNITION PURPOSES IS A VIOLATION OF FEDERAL LAW.

This heater is designed to burn stove size bituminous or anthracite coal and to provide heat to one or more rooms. Because of its radiating characteristics, this heater must be installed as an unenclosed, freestanding unit with clearances to combustibles as specified by these instructions. This heater must be connected to a Listed Factory-Built Residential Type and Building Heating Appliance Chimney or a properly constructed and maintained masonry chimney.

DO NOT CONNECT THIS UNIT TO A CHIMNEY FLUE SERVING ANOTHER APPLIANCE.

This heater is not designed to burn lignite coal, liquid fuels, and gaseous fuels or household refuse. Any attempt to burn these type fuels, to enclose the heater or to attach the heater to an air circulation system or a stoking device can be very hazardous.

THIS HEATER IS NOT DESIGNED TO BE USED IN A MOBILE HOME.

Do Not Overfire - If Heater or Chimney Connector Glows, You are Overfiring.

Improper installation or use of this heater can cause:

1. Damage to the heater from overheating.
2. Hazardous temperatures to develop on combustible materials adjacent to the heater, chimney connector or chimney.
3. Possible hazardous accumulation of coal gases within the heater.
4. Release of hazardous gas into the dwelling.

BUILDING CODES AND SAFETY STANDARDS

Before beginning the installation, you should check

with local building officials to assure compliance with local regulations and codes.

HOW THIS HEATER OPERATES

The chimney draft draws in combustion air through an adjustable air inlet thermostat located inside the cabinet. Air flows through and across the bed of fuel, causing the fire to progress through the fuel bed. Heat is transferred to the air that flows between the cabinet and the firebox. Any attempt to alter this air by connecting this heater to a duct system or air movement fans other than the optional B36 listed blower, available from your heater dealer, can lead to improper and possibly hazardous operation of this heater.

SELECTING A LOCATION FOR THE HEATER

When selecting a location for the heater, be sure attention is given to the following considerations:

1. If the heater is to be vented into a Listed High Temperature Type HT Factory-Built Residential Type And Building Heating Appliance Chimney, review the installation instructions for the chimney to comply with requirements for proper chimney location, height, space requirements, etc.
2. If the heater is to be vented into a masonry chimney, the heater should be located as near the chimney as possible without failing to comply with the requirements for minimum spacing between the chimney connector, heater and combustibles. (Be sure chimney is constructed according to NFPA standards.)
3. The location of the heater must provide at least the minimum clearances between the heater, chimney connector and combustible materials as specified in this manual.
4. If the heater is to be located on a combustible floor, there must be suitable floor space to install a floor protector beneath and extending beyond the heater as shown by and as described by the Floor Protection section of this manual.
5. The heater should be located centrally within the area where heat is desired but out of traffic areas to minimize the likelihood of persons accidentally contacting the hot surface of the heater.
6. The heater should be located away from doorways and central heat outlets and inlets

to reduce the chance of drafts blowing smoke, ashes or sparks out of the heater during refueling or ash removal.

7. The heater should be located where a small supply of fuel may be kept conveniently close but not within 36 inches of the heater.
8. Locate the heater so that drapes, curtains, furniture and other combustible materials will not be closer than the clearances shown in this manual or install a clearance reduction system (see MINIMUM CLEARANCES TO COMBUSTIBLE WALLS AND CEILINGS section of this manual for details).

FLOOR PROTECTION

This heater must have a non-combustible floor protector with a minimum type 1 ember protection extending beneath the heater if the floor is constructed of combustible material. If a floor pad is used, it should be UL listed or equal. The floor protector should be large enough to extend under the stove and beyond each side as indicated. If there is a horizontal run of flue pipe, there needs to be floor protection under it that extends two inches beyond either side of the pipe.

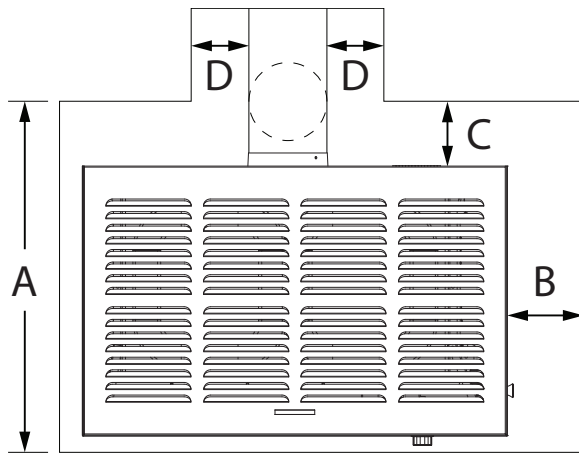

A	35-1/4"
B	16"
C	8"
D	2"

CLEARANCES

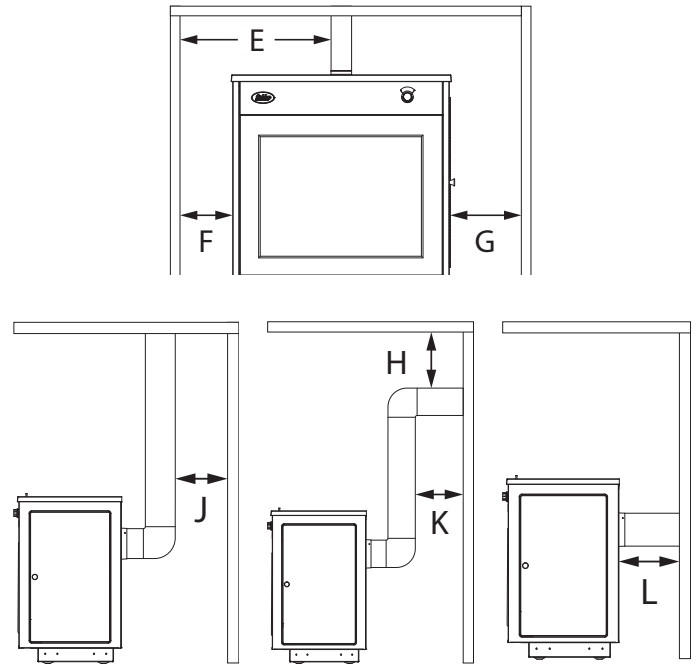

E	29"
F	16"
G	28"
H	18"
J	18"
K	18"
L	18"

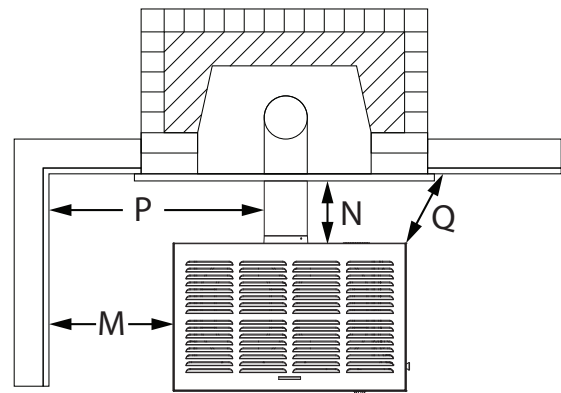

M	16"
N	8" min
P	29" min
Q	18" min

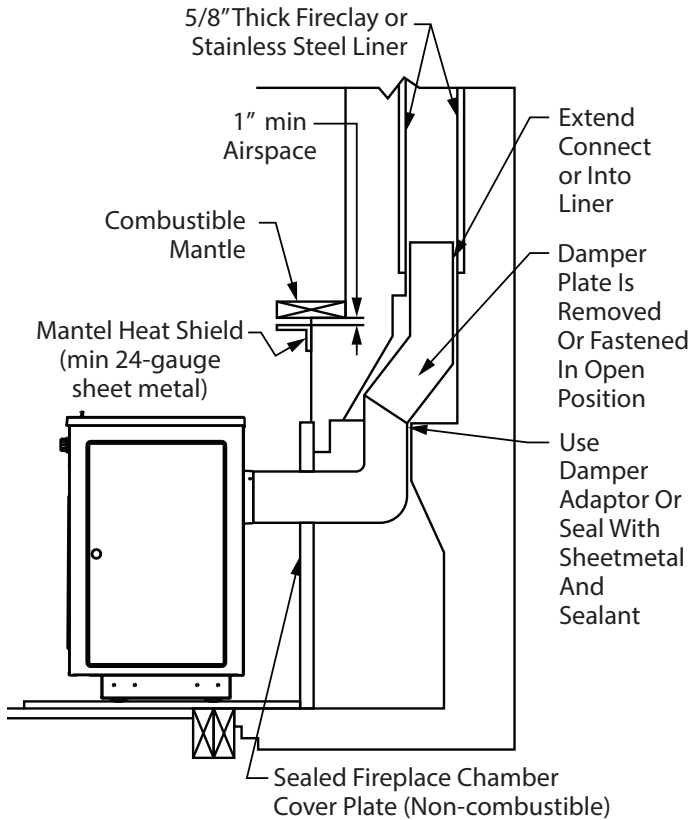

When a metal prefabricated chimney is used, the manufacturer's installation instructions must be followed. You must also purchase (from the same manufacturer) and install the ceiling support package or wall pass-through and "T" section package, firestops (where needed), insulation shield, roof flashing, chimney cap, etc. Maintain proper clearance to the structure as recommended by the manufacturer. The chimney must be the required height above the roof or other obstructions for safety and proper draft operation.

CHIMNEY CONNECTOR AND CHIMNEYS

It is very important to assure safe and satisfactory performance from your heater that it be properly connected to a correctly constructed and maintained chimney. If a Listed High Temperature Type HT Factory-Built Residential and Building Heating Appliance Chimney is used, follow the chimney manufacturer's installation instructions carefully. If a masonry chimney is to be used, be sure it is constructed to the National Fire Protection Association (N.F.P.A) and local code standards. The Chimney connector (pipe from heater to chimney) must be 6" in diameter and made from 24 gauge or heavier steel. The length of the chimney connector and number of elbows* used should be kept to a minimum. Moisture that might collect in the chimney should be directed to the heater by providing a slope of 1/4 inch per foot in a horizontal run of the chimney connector and installing all pipes with the crimped end toward the heater. The chimney connector should extend at least two inches into the flue of a factory-built chimney. When making a horizontal connection to a masonry chimney, the connector should extend to the inside face of the vertical flue liner. When connecting the heater to a masonry fireplace, the chimney connector should extend into the chimney's liner as shown by the side section view. All chimney connector joints should be sealed with furnace cement and secured with #8 sheet metal screws as described by the TO SAFELY AND PROPERLY INSTALL THIS HEATER section of this manual. *Use Corrugated Elbows. DO NOT USE MORE THAN TWO 90 DEGREE ELBOWS IN THE CHIMNEY CONNECTOR. Installations which require two degree elbows must be vented into a flue of at least 8" diameter or 8" square to prevent chimney draft restrictions. DO NOT PASS A CHIMNEY CONNECTOR THROUGH A FLOOR OR CEILING OF

FACTORY BUILT CHIMNEY

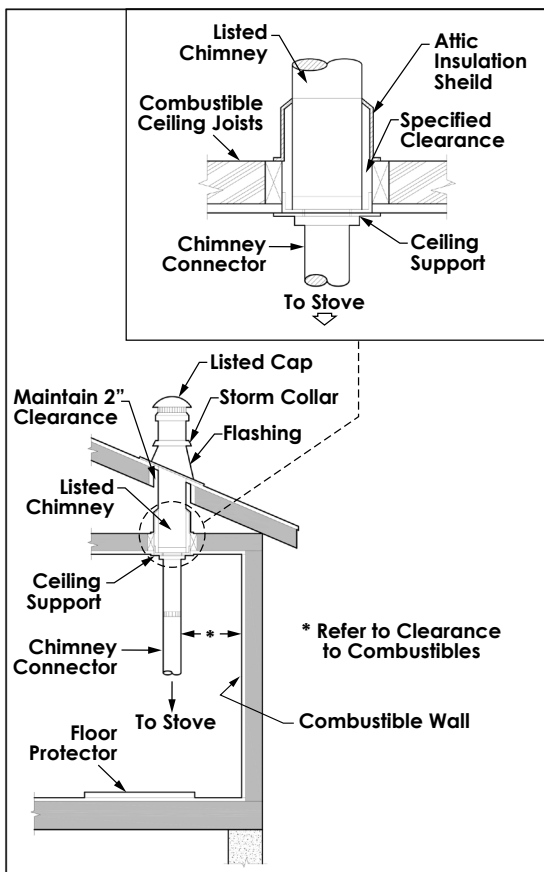

ANY KIND. Only Listed Factory-Built Residential Type and Building Heating Appliance Chimneys or masonry chimneys constructed to N.F.P.A. standards should pass through a floor or ceiling.

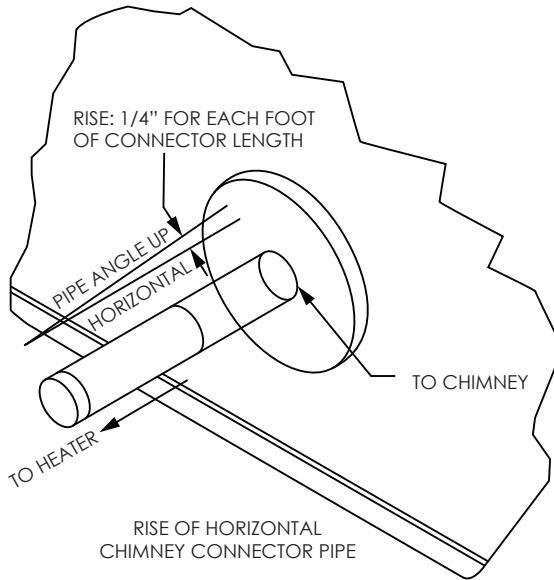

There are five allowable ways that a chimney connector can be connected to a masonry chimney by passing through a combustible wall. NFPA Standard 211 allows the following wall pass-through systems.

1. Use a minimum 3-1/2" thick brick masonry wall framed into the combustible wall. A fireclay liner (ASTM C315 or equivalent) having a 5/8" minimum wall thickness must be used and it must be at least 12" away from any material that could catch fire. The inside diameter of the fireclay liner shall be sized for the proper snug fit of a 6" diameter chimney connector pipe. The fireclay liner shall run from the outer surface of the brick wall to, but not beyond, the inner surface of the chimney flue and shall be firmly cemented in place.

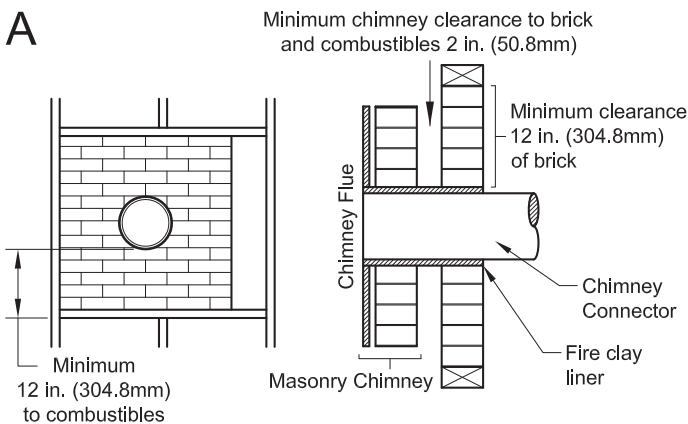

2. Use a solid insulated listed factory-built chimney (UL 103 HT) length having an inside diameter of 6" and having 1" or more of solid insulation. There must be at least a 9" air space between the outer wall of the chimney length and any combustible materials. The inner end of the chimney length shall be flush with the inside of the masonry chimney flue shall be sealed to the flue and to the brick masonry penetration with non water-soluble refractory cement. Sheet steel supports which are at least 24 gauge (0.024") in thickness shall be securely fastened to wall surfaces on all sides. Fasteners between supports and the chimney length shall not penetrate the chimney liner.

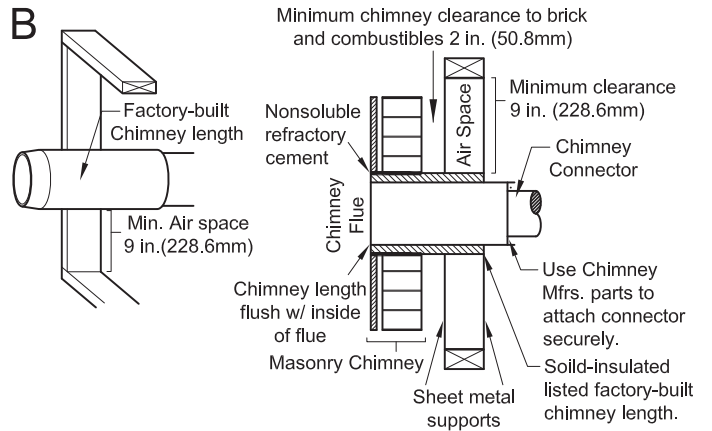

3. Use a 10" diameter ventilated thimble made of at least 24 gauge (0.024") steel having two 1" air channels. The ventilated thimble must be separated from combustible materials by a minimum of 6" glass fiber insulation. The opening in the combustible wall shall be covered and the thimble supported with sheet steel supports which are at least 24 gauge (0.024") in thickness. The sheet steel supports shall be securely fastened to wall surfaces on all sides and shall be sized to fit and hold the chimney section. Fasteners used to secure chimney sections shall not penetrate chimney flue liner.

C

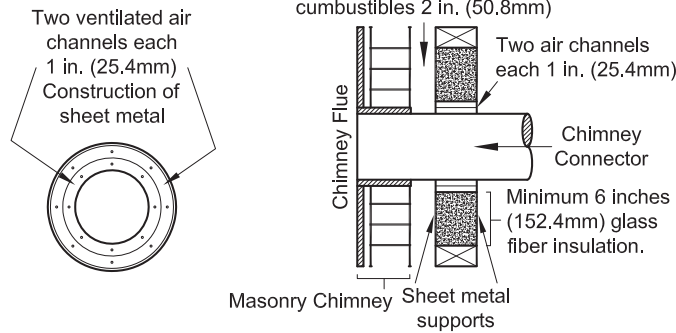

- Use an 8" inside diameter solid insulated listed factory-built chimney length which has 1" or more of solid insulation. The minimum length of this chimney section shall be 12" and will serve as a pass-through for the 6" diameter chimney connector. There must be at least a 12" air space between the outer wall of the chimney section and any combustible materials. The chimney section shall be concentric with and spaced 1" away from the chimney connector by means of sheet steel support plates on both ends of the chimney section. The opening in the combustible wall shall be covered and the chimney section supported on both sides with sheet steel supports which are at least 24 gauge (0.024") in thickness. The sheet steel supports shall be securely fastened to wall surfaces on all sides and shall be sized to fit and hold the chimney section. Fasteners used to secure chimney sections shall not penetrate chimney flue liner.

D

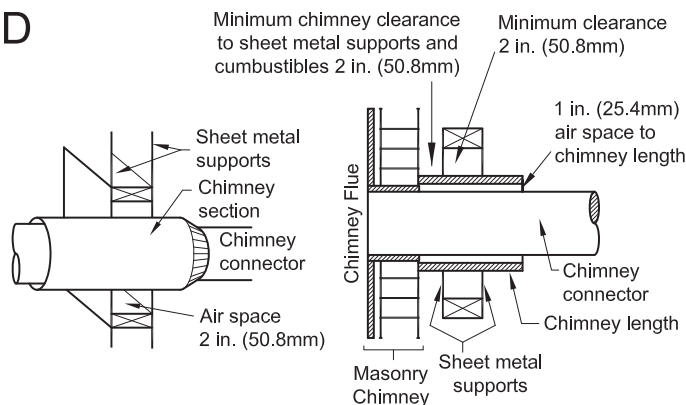

- A listed factory-built wall pass-through system may be purchased and installed according to the instructions packaged with it to provide a safe method of passing the chimney connector through a combustible wall for connection to a masonry chimney.

Additional requirements pertaining to floor protection and the above wall pass-through systems:

- Insulation material used as part of wall pass-through system shall be of noncombustible material and shall have a thermal conductivity of 1.0 Btu · in/ft² · °F (4.88 kg · cal/hr · m² · °C) or less
- All clearances and thicknesses are minimums: larger clearances and thickness are acceptable.
- A chimney thimble, as shown for 3" and 4" above shall be for types "3" and "4" connections to facilitate removal of the chimney connector for cleaning. The chimney thimble shall be of ASTM C315 fireclay with 5/8" minimum wall thickness, or material of equivalent durability. The inside diameter of the thimble shall be sized for the proper snug fit of a 6" diameter chimney connector pipe. The thimble shall be installed without damage to the chimney flue. The thimble shall extend through the chimney wall to, but not beyond, the inner surface of the chimney flue and shall be permanently cemented in place with high temperature cement.
- A chimney connector to a masonry chimney, except for 2" above, shall extend through the wall pass-through system to the inner face of the chimney flue, but not beyond. It does not have to be fastened in place so long as it cannot accidentally be pulled out of the chimney or shoved into the chimney flue. If fasteners are used to secure the chimney connector to a masonry chimney, the fasteners shall not penetrate the chimney flue liner.
- Any material used to close up any opening for the connector shall be noncombustible.

If the chimney connector does not have to pass through a combustible wall to get to a masonry chimney, connect the chimney connector to the masonry chimney as shown. The fireclay liner as shown should be sized for the proper snug fit of a 6" diameter chimney connector pipe. The fireclay liner should be firmly cemented in place as shown. As previously stated, any metal prefabricated chimney this heater is connected to must be a listed Hi-Temp Type HT Factory Built Residential Type and Building Heating Appliance Chimney. When a metal prefabricated chimney is used, the manufacturer's installation instructions must be followed precisely. You must also purchase (from the same manufacturer) and install the ceiling support package or wall pass through and "T" section

package, firestops (when needed), insulation shield, roof flashing, chimney cap, etc. Maintain the proper clearance to the structure as recommended by the manufacturer. This clearance is usually a minimum of 2", although it may vary by manufacturer or for certain components. A listed chimney cap should be installed to prevent entrance of rain and help eliminate down drafts. An unapproved chimney cap, protector or spark arrester can become clogged when leaves or other matter. This blocks the chimney and causes smoke, and the dangerous carbon monoxide in smoke, to spill back into your home where it can kill you.

There are basically two methods of metal prefabricated chimney installation. One method is to install the chimney inside the residence through the ceiling and the roof. The other method is to install an exterior chimney that runs up the outside of the residence. Single wall pipe is not legal for outside installation. REMEMBER: Follow the chimney manufacturer's installation instructions and maintain the manufacturer's specified clearance distance.

Additional chimney information is presented throughout this manual. READ IT THOROUGHLY TO BE MORE THOROUGHLY INFORMED.

PART E

In addition to the methods shown by A, B, C, and D, a listed factory-built wall pass-through system may be purchased and installed according to the instructions packaged with it to provide a safe method of passing chimney connector through a combustible wall for a connection to a masonry chimney.

Connecting Heater's Chimney Connector to Masonry Chimney When Chimney Connector Does Not Have to Pass Through a Combustible Wall

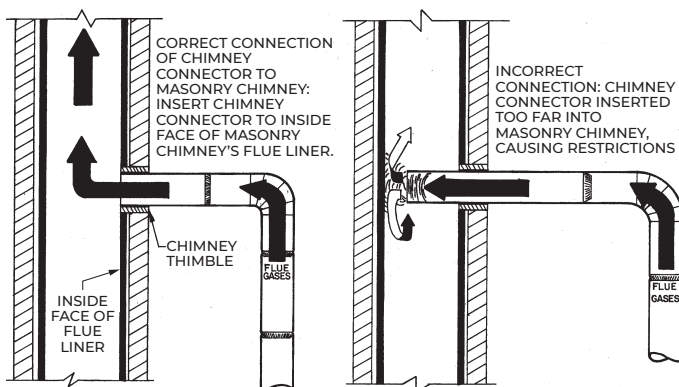

HEATER INSPECTION

Before installing the heater, inspect the heater for external damage and missing parts. Check the gaskets around the doors to assure that they are still in place. Also check inside the heater. Report any deficiencies found to your heater dealer and make sure all problems are resolved before installing the heater.

TOOLS AND SUPPLIES NEEDED FOR INSTALLATION

- Electric drill 1/4 or 3/8 inch drive
- 1/8 inch drill bit
- Screw driver (blade type and size to fit screws listed below)
- No. 8 sheet metal screws (for chimney connector joints)
- Gloves and Safety Glasses
- Ruler or tape measure
- Can or Tube of furnace cement
- Floor Protector
- Rag or several paper towels
- Chimney connector pipes (and elbows, if required)
- Pencil

HEATER INSTALLATION

CAUTION:
IF THIS HEATER IS NOT PROPERLY INSTALLED, A HOUSE FIRE MAY RESULT. FOR YOUR SAFETY, FOLLOW THE INSTALLATION DIRECTIONS. CONTACT LOCAL BUILDING OR FIRE OFFICIALS ABOUT RESTRICTIONS AND INSTALLATION INSPECTION REQUIREMENTS IN YOUR AREA.

CAUTION:
DO NOT CONNECT THIS HEATER TO A CHIMNEY FLUE SERVING ANOTHER APPLIANCE. THERE IS A SERIOUS SAFETY RISK IF TWO APPLIANCES OR HEATERS ARE CONNECTED TO THE SAME FLUE.

CAUTION:

THE HEATER MUST BE PLACED ON A LISTED FLOOR PROTECTOR AS NOTED IN THIS MANUAL IF THE FLOOR IS WOOD OR OTHER COMBUSTIBLE FLOORING. IF CARPET IS PRESENT, IT MUST BE REMOVED. THE FLOOR PROTECTOR MUST NOT BE PLACED ON CARPET.

CAUTION:

MOST WALLS AND CEILINGS CONTAIN WOOD EVEN THOUGH THEY ARE MADE OF SHEETROCK OR PLASTER ON THE OUTSIDE. THESE WALLS AND CEILINGS CAN CATCH FIRE FROM THE HOT HEATER OR CHIMNEY CONNECTOR IF THE HEATER AND CHIMNEY CONNECTOR ARE NOT PROPERLY INSTALLED.

MINIMUM CLEARANCE TO COMBUSTIBLE WALLS AND CEILINGS

Minimum clearances to unprotected combustible walls and ceilings as noted in this manual must be maintained. Drapes, curtains, furniture and other combustible materials should be kept much further away from the heater to avoid a fire. If you chose to, you may install the heater and chimney connector closer to combustible surfaces than indicated in this manual if a clearance reduction system is also installed to protect combustible ceiling and wall near the heater and chimney connector. However, there are limits as to how close the heater and chimney connector can be installed to combustible surfaces protected by a clearance reductions system. A correctly installed clearance reduction system protects the combustible surfaces well beyond the sides and above the top of the heater and beyond the sides and top of the chimney connector pipe. Two common types of clearance reductions systems use sheet metal with a thickness of 28 gauge (galvanized steel, aluminum, copper) or a 3-1/2 inch (4 inch thick nominal) thick masonry wall. Either of these materials must be spaced out 1 inch from the combustible surfaces. With sheet metal, noncombustible spacers are used to maintain the 1 inch air space. With a masonry wall, metal wall ties and furring strips, if needed, are used to anchor the brick to the wall. To avoid excessive heat transmission, the spacers or wall ties should not be placed directly behind the heater or chimney connector. The 1 inch air space provides free air

circulation. It is essential that there be openings at the top and bottom of these clearance reducers so cool air can enter at the bottom and warm air exit at the top. It is the "chimney effect" whereby when the air in the space is heated, it rises exiting from the top and being replaced by cooler air at the bottom, that makes these shields effective. Masonry, or other noncombustible products, attached directly to a combustible surface without an air space offer very little protection and cannot be considered a clearance reduction system unless specific materials have been tested and listed for direct attachment to a combustible surface. The same applies to thin veneer brick and stone coverings. These materials provide adequate protection only when mounted on sheet metal with a 1 inch minimum spacing to the wall. A variety of prefabricated clearance reduction systems which have been safety tested and listed are available through heater dealers. Always look for a safety listing label on the product when selecting a clearance reduction system through a heater dealer and make sure it is designed for use with solid fuel. The manufacturers of these tested and listed systems provide specific installation instructions that must be followed exactly for a safe installation. Should you chose to make your own clearance reduction system, contact your local fire department, fire marshal or building code inspector for specific requirements regarding home-constructed clearance reduction systems and safe installation clearances to protected combustible surfaces.

TO SAFELY AND PROPERLY INSTALL THIS HEATER

1. Install a Listed High Temperature Type HT Factory-built Residential Type and Building Heating Appliance Chimney, build a masonry chimney or adapt an existing chimney to vent the heater. (See the Chimney Connector and Chimneys section of this manual for important information).
2. Purchase the 6-inch diameter chimney connector pipes that are required. The pipe should be black or blued steel, 24 gauge minimum. If elbows are needed, use only seamless elbows because seamed elbows can leak smoke. Do not use more that two elbows or the chimney draft will be restricted (See the Chimney Connector and Chimneys section of this manual for details). Number 8 sheet metal screws and furnace cement will also be needed

to assemble the chimney connector pipes. If the heater is to be installed to a masonry fireplace as shown in this manual, you should also obtain the fireplace items called for in this manual.

3. If the heater is to be installed on a combustible floor, purchase a listed noncombustible floor protector as described in this manual and install it in the proper location. The floor protector MUST protect the floor beneath and around the heater and chimney connector as shown by in this manual.
4. Assemble the chimney connector pipe sections to determine if the chimney connector pipe will correctly extend from the heater flue collar to the chimney. Any horizontal section of chimney connector pipe must slope upward at least 1/4" rise to the horizontal foot to maintain adequate draft. Always install the chimney connector pipe with the crimped end toward the heater to prevent creosote from leaking out of the joints. Always use the least number of chimney connector pipe sections possible. Minimum clearance to combustible walls and ceilings as noted by in this manual MUST always be maintained if a clearance reduction system is not installed.
5. After it is determined that the assembled chimney connector will properly connect the heater to the chimney, disassemble all sections of the chimney connector in preparation for the final assembly procedures.
6. Place the crimped end of the first chimney connector pipe or elbow into the heater's flue collar and mark it through each of the holes in the heater's flue collar.
7. Remove the pipe or elbow from the flue collar and drill 1/8 inch diameter holes at the points marked by step 6.
8. Apply furnace cement to the inside surface of the heater's flue collar, reinstall the first pipe or elbow and fasten in place with No. 8 sheet metal screws. Apply additional furnace cement to the outside of the chimney connector flue collar joint if an airtight seal was not achieved when the pipe or elbow was installed.

9. Assemble the remaining chimney connector pipes by applying furnace cement to the joints, drilling 1/8 inch diameter holes for and attaching each joint with three No. 8 sheet metal screws. Wipe all excess furnace cement from the pipe joints with rag or paper towel. Allow the applied cement to dry before building the first fire in the heater.
10. Depending on your particular type of installation, connect the heater's chimney connector to a masonry chimney as shown in this manual, or connect the chimney connector to a metal prefabricated chimney as specified by the instructions furnished with the metal prefabricated chimney or connect the chimney connector to a masonry fireplace as shown in this manual.

DANGER:

IF ANY CLEARANCE TO UNPROTECTED WALL OR CEILING IS LESS THAN THOSE SPECIFIED IN THIS MANUAL AFTER HEATER INSTALLATION IS COMPLETED, A CLEARANCE REDUCTION SYSTEM MUST BE INSTALLED BEFORE THE FIRST FIRE IS BUILT IN THE HEATER; OTHERWISE, THE UNPROTECTED WALL OR CEILING COULD CATCH FIRE. REMEMBER, THERE ARE ALSO LIMITS AS TO HOW CLOSE THE HEATER CAN BE INSTALLED TO A COMBUSTIBLE SURFACE PROTECTED BY A CLEARANCE REDUCTION SYSTEM. REREAD "MINIMUM CLEARANCES TO WALLS AND COMBUSTIBLE WALLS AND CEILINGS" PRESENTED EARLIER IN THIS MANUAL.

CAUTION:

FOR YOUR SAFETY, CONTACT YOUR LOCAL FIRE DEPARTMENT, FIRE MARSHAL, OR BUILDING CODE INSPECTOR FOR INSPECTION PRIOR TO AND FOLLOWING CLEARANCE REDUCTION SYSTEM AND/OR HEATER INSTALLATION.

NEVER OPERATE THIS PRODUCT WHILE UNATTENDED

IMPORTANT:

DO NOT USE THE HEATER UNTIL A PROFESSIONAL INSPECTION HAS BEEN MADE OF THE ENTIRE INSTALLATION BY YOUR LOCAL FIRE DEPARTMENT, FIRE MARSHAL OR BUILDING CODE INSPECTOR. INSTALL A SMOKE DETECTOR ON EACH FLOOR OF YOUR HOME; IN CASE OF ACCIDENTAL FIRE FROM ANY CAUSE IT CAN PROVIDE TIME FOR ESCAPE.

This heater must be operated as outlined in this manual or a serious fire may occur. THE PAINT ON THE EXTERIOR OF THE FIREBOX WILL GO THROUGH A CURING PROCESS DURING THE FIRST FIRING OF THE HEATER AND WILL EMIT SMOKE AND ODOR. BE PREPARED FOR THIS BY RAISING A WINDOW OR OPENING A DOOR TO PROVIDE VENTILATION. The first three times the heater is fired, the fire should be regulated so as to increase in intensity gradually to allow the painted components to cure slowly and to allow the other components to adjust to their expanded size. Be sure the room is adequately ventilated and the flue unobstructed before beginning a fire in the heater.

TO BUILD A FIRE

1. Set the heater's thermostat control knob to the "Hi" position.
2. Open the heater's fuel feed door and place several wadded grapefruit-size newspaper balls on the heater's grate. Be sure the heater's ash removal door is securely closed.
3. Cover the newspaper balls with dry kindling sticks. Place the kindling sticks close enough to one another so the flames can move easily from one stick to the other. If the kindling is packed too tightly, the fire will suffocate, smoke and then die out. (NOTE: Softwoods make better kindling than hardwoods because softwoods burn faster than the hardwoods.)

NOTE: If the heater tends to smoke when first lit, a draft may be induced by holding a torch of rolled-up newspaper at the opening of the flue collar. Occasionally, this must be done two or three times to establish an updraft before proceeding to the

following step 4. It may also help to open a house door or window slightly.

4. Light the wadded balls of paper in the heater. Leave the fuel feed door slightly ajar (approximately 1 to 2 inches) to allow plenty of oxygen to reach the fire, but DO NOT LEAVE THE HEATER UNATTENDED WHILE ITS FUEL FEED DOOR IS OPEN.

WARNING:

NEVER USE GASOLINE, GASOLINE-TYPE LANTERN FUEL, KEROSENE, CHARCOAL LIGHTER FLUID, OR SIMILAR LIQUIDS TO START OR "FRESHEN UP" A FIRE IN THIS HEATER. KEEP ALL SUCH LIQUIDS WELL AWAY FROM THE HEATER WHILE IT IS IN USE.

CAUTION:

RISK OF EXCESSIVE TEMPERATURES AND DAMAGE TO UNIT-PROPER OPERATION REQUIRES THE USE OF ONLY STOVE SIZE BITUMINOUS OR ANTHRACITE COAL. DO NOT LOAD COAL ABOVE CHAMBER LINERS. OPERATE WITH FEED DOOR CLOSED. DO NOT OVERFIRE-IF HEATER OR CHIMNEY CONNECTOR GLOWS, YOU ARE OVERFIRING. PREVENT SOOT FIRE-INSPECT CHIMNEY CONNECTOR AND CHIMNEY TWICE MONTHLY AND CLEAN IF NECESSARY.

NOTICE:

REMOVE ASHES DAILY, WHEN HEATER IS IN REGULAR USE. IF ASHES ARE ALLOWED TO ACCUMULATE AND BUILD UP AROUND THE GRATES, THE RESULTING LACK OF AIR CIRCULATION CAN CAUSE DAMAGE TO THE GRATES.

CAUTION:

KEEP ASH DOOR CLOSED DURING FIRING OF THE HEATER TO AVOID DEVELOPING EXCESSIVE TEMPERATURES.

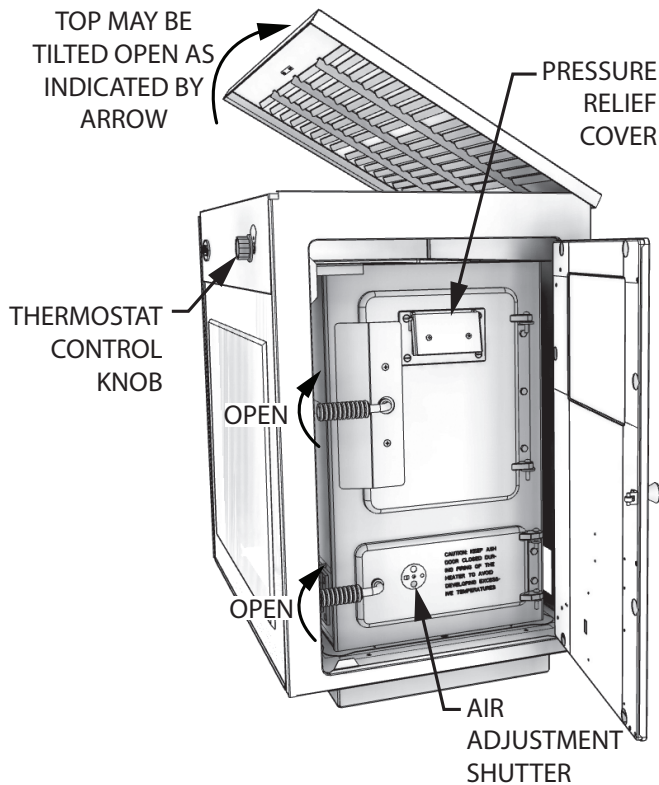

5. When the wood is burning briskly, add additional kindling as required to establish a good kindling fire.
6. When the kindling fire has been established and is burning briskly, cover it with a thin layer of coal. If you add too much coal you will smother the fire, requiring you to start the whole process over again. Be patient.
7. Securely close the heater's fuel feed door as the coal begins burning. **CAUTION: OPERATING THE HEATER WITH ITS FUEL FEED DOOR OR ASH REMOVAL DOOR OPENED CREATES AN ABNORMAL FIRING CONDITION WHICH CAN OVERHEAT THE HEATER, CHIMNEY AND ADJACENT COMBUSTIBLE MATERIALS. THIS CAN DRASTICALLY SHORTEN THE HEATER'S LIFE AND VOID THE FACTORY WARRANTY.**
8. Wait about ten minutes, or until the coal is burning well, then start adding small quantities of coal at ten minute intervals until a good coal fire is established.

CAUTION:

- **NEVER ADD MORE COAL THAN IS ALREADY BURNING AND NEVER ADD MORE THAN TEN POUNDS OF FRESH COAL AT ONE TIME.**
- **WHEN FRESH COAL IS ADDED, ALWAYS LEAVE SOME OF THE GLOWING COALS UNCOVERED.**
- **NEVER FILL THE HEATER SO THAT THE BURNING COAL IS ABOVE THE TOP OF THE HEATER'S CHAMBER LINERS. THIS WILL CAUSE THE HEATER TO OVERHEAT AND WILL SHORTEN ITS LIFE.**

9. MAKE SURE THAT THE HEATER'S FUEL FEED DOOR, ASH REMOVAL DOOR, AND CABINET DOOR ARE SECURELY CLOSED.
10. Set the heater's thermostat control knob to a point midway between "HI" and "Lo". If the house or heating situation requires a higher or lower setting to obtain the desired amount of heat, adjust the heat's thermostat control knob accordingly.

OPENING & CLOSING FUEL FEED DOOR

OPEN: When closed and latched, the door and handle will be as shown in position number 1. Rotate the handle until it is as shown in position number 2. Pull the door open until it stops, approximately one inch as shown in position 3. Continue to hold the door open as the handle is returned to its original position. The door will then open completely as shown in position number 4.

CLOSED: With the handle as shown in position number 4, close the door as far as possible. Now rotate the handle to position number 3 and completely close the door as shown in position number 2. Rotate the handle as shown in position number 1 and apply sufficient pressure to insure that the door is sealed.

POSITION #1 **POSITION #2**

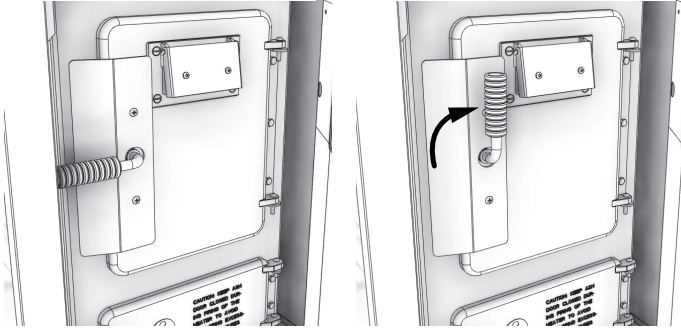

POSITION #3 **POSITION #4**

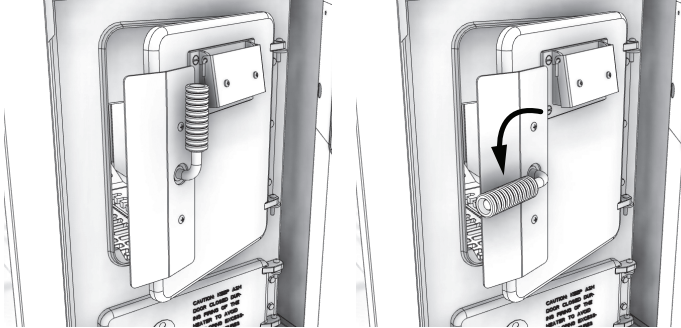

FIRE TENDING

Fire tending is the occasional poking or stirring of the burning coal bed to ensure airflow through the coal bed and adding fresh coal as needed. With experience, you should determine how often fire tending is required to maintain the desired heat output of the heater. To ensure safe and satisfactory performance of the heater, the following rules should be observed:

1. KEEP THE FUEL FEED DOOR AND ASH REMOVAL DOOR CLOSED EXCEPT WHEN TENDING THE FIRE OR REMOVING ASHES. Operating the heater with either of these doors open can cause the heater to dangerously overheat and will increase the possibility of smoke, ash or sparks escaping the heater and damaging the dwelling or its contents.
2. NEVER FILL THE HEATER ABOVE THE TOP OF THE CHAMBER LINERS. Overfilling the heater can cause it to overheat, create a fire hazard, and damage the heater.
3. NEVER OPEN THE FUEL FEED DOOR WITHOUT FIRST TURNING THE THERMOSTAT CONTROL KNOB TO "HI" FOR AT LEAST 30 SECONDS.
4. NEVER ADD MORE THAN TEN POUNDS OF FRESH COAL TO THE HEATER AT EACH

REFUELING. Adding large amounts of fresh coal can cause an accumulation of gases above the fire that can cause backpuffing. Backpuffing can occur whenever concentrated gases accumulate over the fire bed and then catch fire quickly. This may cause smoke and flame to be expelled from the heater during fire tending. Under rare conditions, backpuffing can be severe enough to break apart poorly connected chimney connector pipes. If backpuffing is experienced, see TROUBLESHOOTING section of this manual. Backpuffing is an abnormal condition and a potential hazard. Determine and correct the cause.

5. TURN THERMOSTAT TO "HI" FOR 15 MINUTES AFTER ADDING FRESH COAL TO A FIRE. This allows the gases to be driven off and shortens the length of time the dense smoke is likely to deposit soot on the chimney walls.
6. DO NOT TAMPER WITH THE INTERNAL THERMOSTAT MECHANISM. The thermostat has been designed and calibrated to provide continuous control of the fire for safety and efficiency. Thermostat adjustments are made with the thermostat control knob only.
7. PREPARE THE HEATER TO HOLD FIRE ALL NIGHT BY LOADING IT WITH COAL AT LEAST AN HOUR BEFORE BEDTIME. Burn the heater at the normal rate for this hour, then turn it back to a slower burn just before going to bed. This procedure will help drive excess moisture and gases out of the coal and minimize soot buildup during the night. This procedure also minimizes the likelihood of backpuffing.
8. DO NOT OVER FIRE THE HEATER. If any part of the heater or chimney connector becomes red hot, the heater is being over fired. Immediately turn the heater's thermostat to "LO" and keep the fuel feed door and ash removal door closed until the heater cools.

DO NOT OVER FIRE THE HEATER. If any part of the heater or chimney connector becomes red hot turn the thermostat to low and keep the ash and feed doors closed until the heater cools.

MINIMUM FIRE ADJUSTMENT

Soot is more likely to accumulate in the chimney connector and chimney liner during extended periods of low firing. This accumulation can be

reduced by proper setting of the air shutter on the ash door. Rotating the air shutter to allow more air into the fire chamber will increase the rate of the minimum fire and reduce the accumulation. Experience in a particular heating situation will give guidance in choosing the best setting. Setting changes are made with common pliers. Set the shutter to the largest opening and use a smaller opening only if the heat output cannot be adequately controlled by the thermostat.

COAL FACTS

Anthracite coal (known as hard coal) is the only coal with a uniform sizing scale. Before leaving the coal mine, it is graded into one to the following categories:

- Nut - from 13/16" to 1-5/8" in diameter.
- Stove - from 1-5/8" to 2-7/16" in diameter.
- Egg - from 2-7/16" to 3-1/4" in diameter.
- Broken - more than 3-1/4" in diameter.

Anthracite coal is hard to ignite; but once it is burning, it burns freely and cleanly and very hot. It does not fuse but leaves substantial ash residue. When anthracite burns with a blue flame, it is burning properly and the volatile gases released from the coal are being consumed by the fire. Bituminous coal is easier to ignite than anthracite coal. Most people think anthracite has a higher heat content than bituminous, but in actuality, some bituminous is as good as anthracite. Bituminous breaks up more in storage and burns with more smoke than does anthracite. One other

characteristic of bituminous which differentiates it from anthracite is that, as the coal burns, it tends to form clinkers whereas anthracite is reduced mainly to ash. Clinkers are the misshapen, rough, gray lumps that form when particles in the coal are heated, melt and fuse together. When bituminous burns with a yellow flame, it is burning properly and the volatile gases being released from the coal are being consumed by the fire. Of these two coals, anthracite is the more expensive. Store in a dry, ventilated space.

Coal that is improperly stored can catch fire from heat generated by chemical changes occurring within the coal bed (spontaneous combustion). To avoid the development of these conditions, coal quantities that will be stored more than three days should be kept clean of all combustible materials, such as leaves, hay, wood, rags, etc., and stored where the temperature of the air and objects the coal contacts are 75 degrees F. or less. Alternate wetting and drying of coal should be avoided. Wet and dry coal should never be stored where each will be in contact with the other. If the emission of heat or unusual odors from a coal storage area is observed, the process leading up to spontaneous combustion may be occurring and the fire department should be called immediately. Small quantities of coal required for fire tending must be kept at least 36" from the heater.

HOW TO TAKE CARE OF THE HEATER AND VENTING SYSTEM (ROUTINE MAINTENANCE)

The heater's outer cabinet may be wiped free of dust with a soft cloth. The use of any other cleaning method may damage the cabinet's finish. Inspect and clean chimney frequently - under certain conditions of use, creosote buildup may occur rapidly. Check the following items regularly during the heating season to ensure proper heater operation:

1. Condition of feed door and ash door gaskets--replace if excessive wear is observed.
2. Condition of feed door, ash door, and cabinet latching pawls and handles--ensures that operation will securely close the door. Adjust as necessary.

At the end of each heating season, the heater should be thoroughly cleaned of all ashes. Ashes remaining in the heater in combustion with moisture in the air can cause severe corrosion of the heater. All rust spots on the heater should be wire brushed and covered with a coat of high temperature paint. If the heater is to be stored until the next heating season, be sure the storage area is dry. The heater should never be used with damaged or missing parts. However, overtime the heater may become distorted.

DISPOSAL OF ASHES

The ashes should be removed from the heater anytime they accumulate to within 2 inches of the grate and at least once each day. Chunks of ash material called clinkers may accumulate above the grate. These can be removed by shaking the grate with the shaker. To minimize the loss of burning coal into the ash pan, do not shake the grate when a large fire is in progress. When removing the ash pan from the heater, wear gloves to protect your hands from glowing embers and hot surfaces.

ASHES SHOULD BE PLACED IN A METAL CONTAINER WITH A TIGHT FITTING LID. THE CLOSED CONTAINER OF ASHES SHOULD BE PLACED ON A NONCOMBUSTIBLE FLOOR OR ON THE GROUND, WELL AWAY FROM ALL COMBUSTIBLE MATERIALS, PENDING FINAL DISPOSAL. IF THE ASHES ARE DISPOSED OF BY BURIAL IN SOIL OR OTHERWISE LOCALLY

DISPERSED, THEY SHOULD BE RETAINED IN THE CLOSED CONTAINER UNTIL ALL CINDERS HAVE THOROUGHLY COOLED.

Ashes should never be placed in wooden or plastic containers, or in paper or plastic bags, no matter how long the fire has been out. Coals have been known to stay hot for several days when embedded in ashes.

VENTING SYSTEM (CHIMNEY CONNECTOR & CHIMNEY)

The venting system consists of the heater's chimney connector (the pipe which connects the heater to the chimney) and the chimney itself.

SOOT - FORMATION & NEED FOR REMOVAL

When coal is burned, the products of combustion combine with moisture to form a soot residue which accumulates on the flue lining. When ignited, this soot makes an extremely hot fire. The chimney connector and chimney should be inspected at least once every two months during the heating season to determine if a soot buildup has occurred. If soot has accumulated, it should be removed to reduce the risk of a chimney fire. A chimney fire is usually indicated by a roaring noise from within the chimney and/or a pinging noise within the chimney connector. Well developed chimney fires will emit ash and sparks from the top of the chimney. If a chimney fire occurs, turn the thermostat to "LO", keep the feed door, ash and cabinet doors closed, call the fire department and protect the roof by wetting it with a garden hose or buckets of water. After the chimney fire is over, thoroughly inspect all combustible materials around the chimney and chimney connector for fires that might have been ignited by the intense heat. The chimney and chimney connector should then be inspected for any damage and repairs made if necessary. Although a properly constructed chimney should not be damaged by a chimney fire, it is best to prevent chimney fires by properly cleaning the chimney. There are special chimney cleaning services available in most cities. Most fire departments make free chimney inspections and can provide assistance in locating chimney cleaning or repair services.

CHIMNEY CONNECTOR PIPE-CORROSION INSPECTION

Chimney connector pipes do not last forever. Corrosion is particularly a problem if the inside of the pipe tends to get damp from condensation of flue gases or from rain or snow getting into the chimney. Just being on an ocean coast can also

accelerate chimney connector pipe corrosion. Chimney connector pipe replacement may be necessary more than once a season, but once every few years is more typical. Every time the chimney and chimney connector are checked for creosote buildup, the strength and integrity of the chimney connector pipes should also be checked.

TROUBLESHOOTING

Problems can arise during the operation of any coal heater. These problems can usually be traced to such things as the venting system, draft, aged or failed parts, fuel, and operator error. The troubleshooting suggestions contained in this section of the manual apply to the operation of all coal heaters. Experience has shown that correct installation and good operating practices-including routine heater and venting system maintenance, along with a good sound chimney, will eliminate most of the problems mentioned by this section of the manual. Nonetheless, coal heater operators should make themselves aware of the nature, cause and solution to possible problems so as to help themselves obtain the best possible service from this heater.

VENTING SYSTEM-KEY TO GOOD HEATER PERFORMANCE

A majority of performance problems with coal burning heaters can be traced to some factor in the venting system that is adversely affecting the heater. Air will flow into the heater and smoke will flow up the chimney only if there is sufficient difference between the air pressure in the room where the heater is located and the air pressure inside the chimney. As hot gases and smoke flow up a chimney, the pressure in the chimney is lowered, creating a difference in pressure inside and outside the chimney. When this pressure difference, often referred to as "draft pressure" or simply as "draft", is sufficient, air will be drawn into the heater through its thermostatically controlled inlet air damper. This air supplies the oxygen necessary for the coal to burn. If the draft is not sufficient, insufficient oxygen will reach the burning fuel and it will burn poorly. This condition can also cause smoke and dangerous gases to spill or backpuff from the heater into the room. Backpuffing occurs when the air flow through the heater is insufficient to burn all

the gases being released by the coal causing them to build up until they ignite as a minor explosion. This causes smoke to puff out of every opening in the heater and venting system. Too much draft may cause excessive temperature in the heater. An uncontrollable burn or a glowing red heater part or chimney connector is an indication of excessive draft. The amount of draft in the chimney depends on the length of the chimney, local geography, nearby obstructions (even a tree that has grown tall can affect the draft of a chimney that was previously trouble-free), and other factors. The common unit used to measure draft is "INCHES IF WATER". To determine the draft of your chimney, a draft pressure reading should be taken with a DRAFT METER or a WATER MANOMETER. This requires someone with proper equipment and knowledge of how to use it. Your heater dealer should be able to perform this task for you or recommend someone who can. For this heater, installations with a draft of .02 inches of water or less are considered marginal and will not burn reliably as noted above. For this heater, it is not recommended that the draft exceed .06 inches of water or over firing can occur as noted above. The recommended operating range for this heater is .03 to .06 inches of water.

IF THE HEATER SMOKES OR BURNS POORLY OR EXCESSIVE CREOSOTE ACCUMULATES IN THE CHIMNEY

1. Open a window slightly to see if the conditions improve. If opening a window improved the performance of the heater or stops the spillage of smoke into the room, the problem is caused by a slight vacuum in the room. The vacuum can be the result of the room being so tightly constructed that the air removed from the room by the heater is not replaced by normal infiltration of air from outside the room.

- The vacuum can also be caused by the loss of air from the room through the kitchen or bathroom ventilating fans, other chimneys or vents, etc. The only solution to this type problem is to reduce the air lost from the room or provide a source for air to enter the room.
- Check the pipes connecting the heater to the chimney for loose or unsealed joints that may allow air to leak into the chimney system.

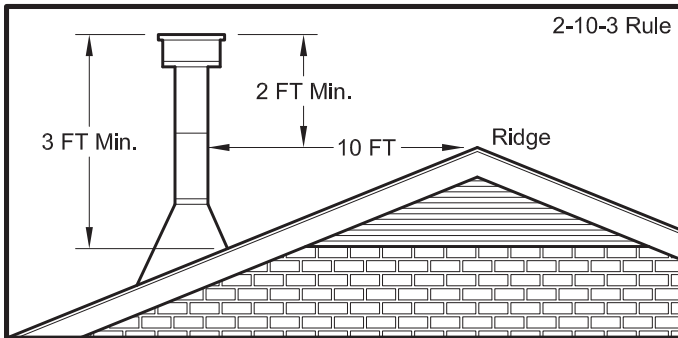

NOTE: Chimney height 3ft minimum (unless any obstruction is 10ft or less away from the outlet then chimney height must be (X) plus 2ft or the eft minimum, whichever dimension is greatest. X equals height of obstruction. Masonry chimney shown dimensions are same for metal prefabricated chimney.

- Examine your method of building and tending the fire in the heater. If you add too much fresh coal at each refueling, or attempt to operate the heater at too low a combustion rate for the amount of coal present in the firebox, your failure to follow proper practices may be causing the problem. Also check for ash buildup in the ash pan. Ashes can restrict air flow through the burning coal.
- Check the height of the chimney. A chimney that is too short will not develop sufficient draft or allow wind to interfere with the draft.
- Check the chimney for cracks or holes that might allow air to leak into the chimney. If the chimney is equipped with an ash clean out, be sure the door is closed and fits tightly. The door may have to be temporarily sealed with tape or furnace cement to be as air tight as required. An excellent way to check an exterior chimney for leaks is to preform a smoke test building a small coal fire in the heater, adding a small amount of coal to the fire to make it smoke heavily, momentarily blocking the top of the

chimney, and watching for smoke to leak out of any opening or cracks.

- Check the entire system for obstructions that could be causing resistance to the flow of smoke and gases up the chimney.
- Check the size of the chimney flue liner. If the chimney flue liner's inside dimension is smaller than 6 inches round or 8 inches square, it will be too restrictive to the flow of smoke and gases. A chimney flue liner which has an inside cross-sectional area of more than 85 square inches is too large, which will result in excess capacity, which means less draft and more creosote. If the chimney flue liner is too large, it may be improved by restricting the top opening of the flue to a 6 inch round opening, or in more extreme cases, the chimney may have to be relined with a smaller lining and a metal prefabricated chimney may have to be replaced.

WHAT TO DO IF THE HEATER BURNS TOO RAPIDLY OR OVERHEATS

- If the room in which the heater is located becomes uncomfortably warm on moderately cool days, it may be because you are placing too much fuel in the heater for the amount of heat required to heat your home. Although the thermostatically controlled inlet air damper on the heater is intended to control the burning rate of the fuel, a certain amount of air must enter the heater at all times to assure the fire does not go out and the fuel burns as cleanly as possible. Thus you should adjust the amount of fuel you put in the heater to the outdoor temperature. Placing excessive fuel in the heater will cause excessive creosote formation in the chimney, waste fuel, and make the room uncomfortably warm.
- If the heater burns too rapidly or overheats, it may be because air is leaking around a loose door gasket or a fuel feed door or ash door latching pawl and handle may need adjusting. Check thoroughly for leaks where air may be entering the heater's firebox.
- If the heater burns too rapidly or overheats due to excessive draft as described earlier, you may wish to consider purchasing a barometric damper top to be installed in the heater's chimney connector. The barometric damper should be set to regulate a .06 draft through the heater. Check with your heater dealer.

QUICK REFERENCE FOR COMMON OPERATIONAL PROBLEMS

Symptom	Check for
Fire rate does not increase with thermostat open, smoke spilling from feed door when tending fire or backpuffing. or Smoke smell in living space.	Chimney connector pushed too far into a masonry chimney thimble restricting draft.
	Chimney or chimney connector restricted with creosote.
	Chimney draft reduced by air entering through: <ul style="list-style-type: none"> • Unsealed chimney clean-out access. • Loose mortar or cracked chimney wall. • Holes in rusted chimney connector. • Incompletely sealed chimney connector joint or thimble
	Downdraft in too large chimney or chimney with no cover.
	Combustion air inlet blocked with ashes.
	Chimney too short.
Fire rate too high when thermostat closed.	Feed door or ash door not securely closed.
	Feed door or ash door gasket worn excessively.

FINAL CHECKLIST, DO'S AND DON'TS

Do's:

1. Do read and follow the installation, operation and maintenance manual carefully.
2. Do install a smoke detector in an area that will give warning in the unlikely event that a fire develops in the area of the heater or the heater malfunctions.
3. Do be sure that there is a fire extinguisher of the proper type and in good working order accessible in the unlikely event that a fire develops near the heater of the heater malfunctions.
4. Do check with local building officials to be sure installation of the heater complies with all building codes and requirements and obtain required building permits.
5. Do plan your installation with safety as your primary consideration.
6. Do keep all flammable liquids, gases and pressurized containers away from heater.
7. Do complete the installation before attempting to use the heater.
8. Do use only the prescribed materials and parts for the installation of the heater.
9. Do install the heater in an area that will minimize the hazards of persons coming in contact with the hot surfaces of the heater.
10. Do instruct all responsible persons in the proper and safe operation of the heater.
11. Do instruct all persons, especially children and elderly persons, of the hazards involved with the heater and improper and unauthorized tampering with the heater.
12. Do check the heater for proper adjustment and operation before leaving it unattended for long periods of time.
13. Do start a fire only with paper, kindling or solid composition fire starters specifically designed for starting a fire. The use of liquid fire starters can cause an explosion within the heater.
14. Do use only a Listed High Temperature Type HT Factory-built Residential Type and Building Heating Appliance Chimney or a properly constructed and maintained masonry chimney to vent this heater.
15. Do use 6-inch diameter chimney connector pipes made from a minimum of 24 gauge cold rolled steel.
16. Do place all ashes in a metal container with a tight fitting lid and place them on a noncombustible surface well away from other combustible materials until they have completely cooled.
17. Do check the door latching mechanisms and gaskets regularly and replace parts or make adjustments as needed to maintain the intended tightness of the fire chamber.
18. Do use a noncombustible floor covering beneath the heater as required.
19. Do observe all instructions regarding clearance between the appliance, chimney connector and combustibles.
20. Do store your fuel supply at least 36 inches from the heater.

21. Do build fires of moderate intensity in the appliance for the first three fires to allow the materials to adjust and cure before being subjected to the intense heat of a large fire.
22. Do be sure the heater is located in an area where combustible vapors are not present.
23. Do use a chimney for this heater that is not used by another appliance.
24. Do assemble the chimney connector so that moisture that accumulates within the chimney will flow back toward the heater.
25. Do remove the ashes from the heater regularly.
26. Do set the thermostat on "HI" and allow the heater to burn for approximately 15 minutes after fresh coal is added before reducing the thermostat setting.
27. Do store coal in such a manner that wet and dry coal will not mix.
28. Do protect your hands with noncombustible gloves when loading the heater, removing ashes, etc.
29. Do keep the heater doors closed except when refueling the heater or removing ashes.
6. Don't store ashes in combustible containers, not store them near combustible materials nor dispose of them until they have completely cooled.
7. Don't use power blowers or air circulation systems with this heater that are not specifically recommended in this manual.
8. Don't neglect to inspect regularly and maintain door gaskets and latching mechanisms to assure the intended tightness of the fire chamber.
9. Don't install the heater or chimney connector at clearances less than those specified in this manual.
10. Don't install this heater where flammable or explosive materials or vapors are likely to be present.
11. Don't install this heater in a chimney flue that is used by another appliance.
12. Don't neglect to clean and inspect your chimney regularly.
13. Don't operate this heater with the doors open.
14. Don't use the heater with missing or damaged parts.

DON'TS

1. Don't dry clothing or other articles on or near the heater.
2. Don't store or place flammable liquids, gases, or other pressurized containers near the heater.
3. Don't use gasoline, gasoline type lantern fuel, kerosene, charcoal lighter fluid, or similar liquids to start or intensify a fire. Using these and other similar materials can cause an explosion within the heater.
4. Don't use an unlisted, type B, or poorly constructed or maintained chimney to vent this heater.
5. Don't use galvanized pipe, steel pipe less than 24 gauge, or pipe of a diameter smaller than 6 inches as a chimney connector.

SAFETY NOTICE

In the unlikely event that your heater "overfires" (a condition evidenced by elbows, stovepipes, and connectors glowing red in appearance or otherwise discoloring), then your installation is subject to excessive draft created by either a chimney too tall or too great in diameter in conjunction with its height, or some other factor of an indeterminate cause. In this event, you should install a barometric draft regulator. Such installation will preclude any overfiring and/or any hazardous consequences of potential over firing.

Barometric Draft Regulators are generally available where you purchased your stove or may be ordered directly from United States Stove Company at a nominal charge.

PARTS DIAGRAM

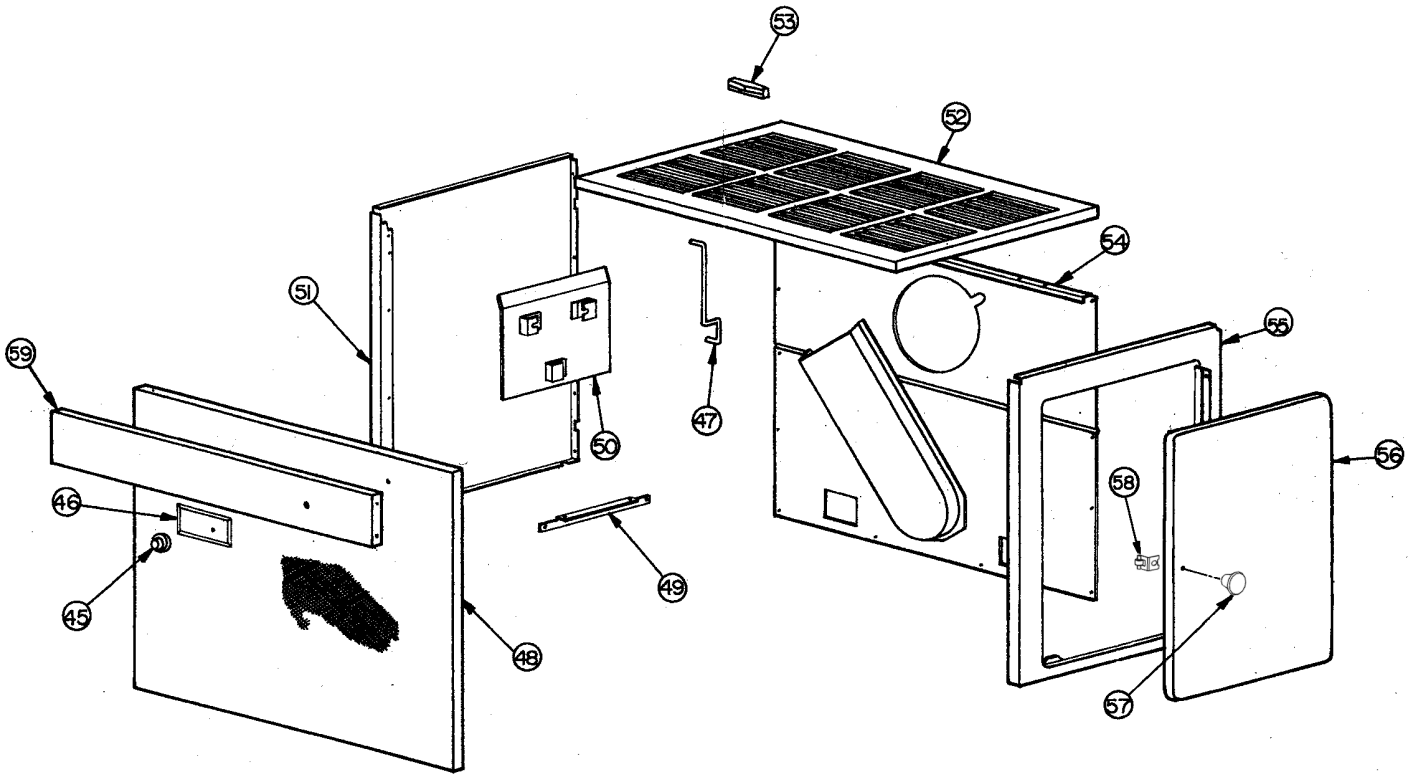
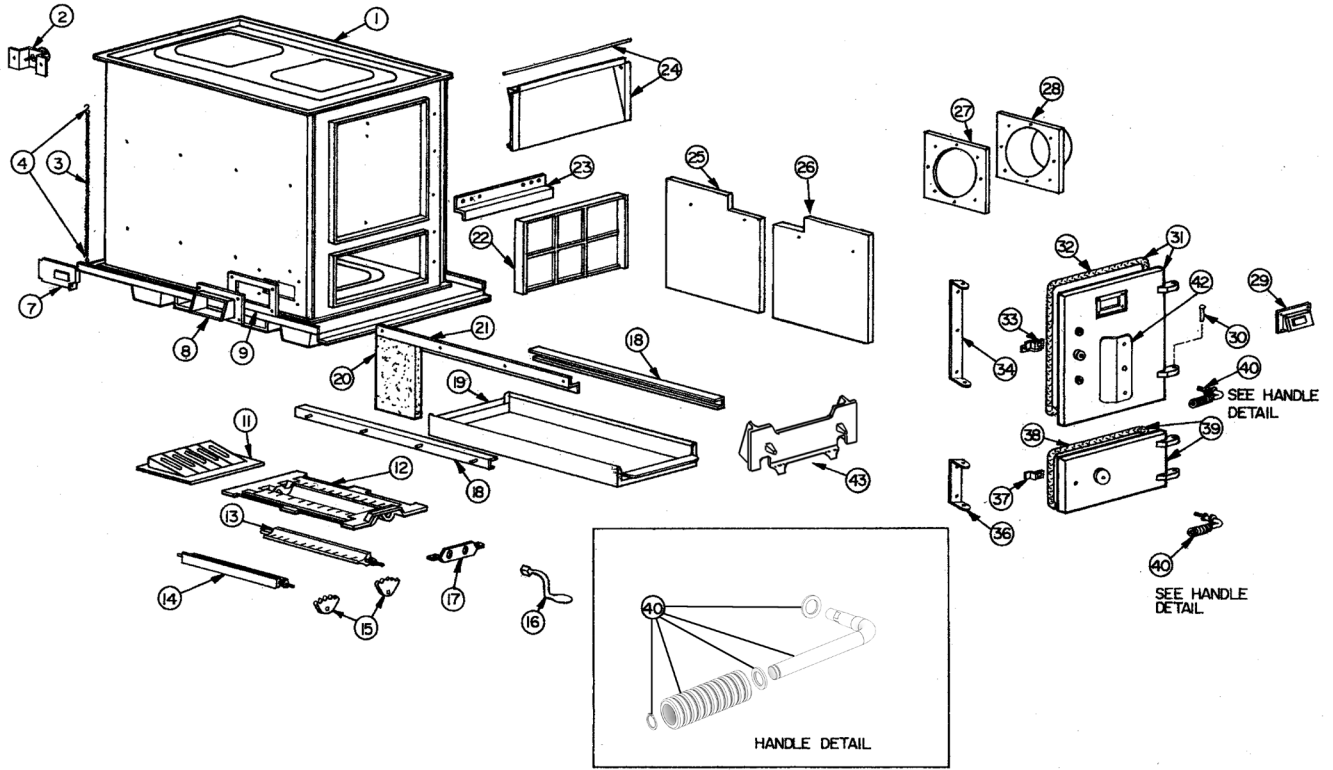

KEY	PART #	DESCRIPTION	QTY
1	69212B	Inner Unit Assy.	1
2	69532	Thermostat Assy.	1
3-4	24850	Chain & "S" Hook	2.5 ft
7	69207B	Draft Plate Assy.	1
8	24812	Manifold Assy.	1
9	88090	Manifold Gasket	1
11	40383	Grate Extension	1
12	40386	Grate Frame	1
13	007716R	Right Grate	1
14	007717R	Left Grate	1
15	40415	Grate Cog	2
16	40380	Shaker Handle	1
17	25079	Cog Retainer	1
18	69205	Angle Grate Support Assy.	2
19	69206	Ash Pan Welded	1
20	89066	Ceramic Brick (6 Pack)	10
21	40132	Side Brick Retainer	2
22	40385	Rear Liner	1
23	40381	Rear Retainer	1
24	24835	Smoke Curtain Assy.	1
25	40390	Liner Kit	1
26	40391	Liner Kit	1
27	88094	Gasket	1
28	24819	Flue Collar	1
29	24812	Maniflod Relief Assy.	1
30	83485	Door Pin	4

31	69209	Feed Door & Rope Assy.	1
32	DGK3	Feed & Ash Door Gasket Kit	1
33	22434	Latch (Long)	1
34	24837	Hinge Kit, Feed Door	1
36	24838	Hinge Kit, Ash Door	1
37	25048	Latch Kit For Ash Door	1
38	-----	Refer To Item 32	-
39	69208	Ash Door & Rope Assy.	1
40	89930	Handle Kit	2
42	24828	Radiation Shield Kit	1
43	40412	Front Liner	1
45	89142	Knob, Thermostat	1
46	851397	Control Plate	1
	M 851728	Control Plate	
47	24849	Rod And Nut Assy.	1
48	69224GO	Trim And Screen Assy.	1
49	24851	Left & Right Top Brace	2
50	24824	Radiation Shield Kit	1
51	69221B	Left Side Cabinet Assy.	1
52	69202B	Cabinet Top Assy.	1
53	891591	Cabinet Top Handle Kit	1
54	25597B	Panel Back	1
55	69220B	Right Side Cabinet Assy.	1
56	69219B	Cabinet Door Assy.	1
57	89635	Door Knob	1
58	83093	Stove Spring Latch	1
59	25551B	Top Front Panel	1

To order parts:

Call 1-800-750-2723 Ext 5051 or

Email to: parts@usstove.com

IN ORDER TO MAINTAIN WARRANTY, COMPONENTS MUST BE REPLACED USING ORIGINAL MANUFACTURERS PARTS PURCHASED THROUGH YOUR DEALER OR DIRECTLY FROM THE APPLIANCE MANUFACTURER. USE OF THIRD PARTY COMPONENTS WILL VOID THE WARRANTY.

SERVICE RECORD



It is recommended that your heating system is serviced regularly and that the appropriate Service Interval Record is completed.

SERVICE PROVIDER

Before completing the appropriate Service Record below, please ensure you have carried out the service as described in the manufacturer's instructions. Always use the manufacturer's specified spare part when replacement is necessary.

Service 01	Date: _____
Engineer Name: _____	
License No.: _____	
Company: _____	
Telephone No.: _____	
Stove Inspected: <input type="checkbox"/>	Chimney Swept: <input type="checkbox"/>
Items Replaced: _____	

Service 02	Date: _____
Engineer Name: _____	
License No.: _____	
Company: _____	
Telephone No.: _____	
Stove Inspected: <input type="checkbox"/>	Chimney Swept: <input type="checkbox"/>
Items Replaced: _____	

Service 03	Date: _____
Engineer Name: _____	
License No.: _____	
Company: _____	
Telephone No.: _____	
Stove Inspected: <input type="checkbox"/>	Chimney Swept: <input type="checkbox"/>
Items Replaced: _____	

Service 04	Date: _____
Engineer Name: _____	
License No.: _____	
Company: _____	
Telephone No.: _____	
Stove Inspected: <input type="checkbox"/>	Chimney Swept: <input type="checkbox"/>
Items Replaced: _____	

Service 05	Date: _____
Engineer Name: _____	
License No.: _____	
Company: _____	
Telephone No.: _____	
Stove Inspected: <input type="checkbox"/>	Chimney Swept: <input type="checkbox"/>
Items Replaced: _____	

Service 06	Date: _____
Engineer Name: _____	
License No.: _____	
Company: _____	
Telephone No.: _____	
Stove Inspected: <input type="checkbox"/>	Chimney Swept: <input type="checkbox"/>
Items Replaced: _____	

Service 07	Date: _____
Engineer Name: _____	
License No.: _____	
Company: _____	
Telephone No.: _____	
Stove Inspected: <input type="checkbox"/>	Chimney Swept: <input type="checkbox"/>
Items Replaced: _____	

Service 08	Date: _____
Engineer Name: _____	
License No.: _____	
Company: _____	
Telephone No.: _____	
Stove Inspected: <input type="checkbox"/>	Chimney Swept: <input type="checkbox"/>
Items Replaced: _____	

