



OWNER'S MANUAL

Altitude™ Series
(A42 illustrated)



For indoor use only

SAFETY INFORMATION

⚠ WARNING

FIRE OR EXPLOSION HAZARD

Failure to follow safety warnings exactly could result in serious injury, death, or property damage.

- Do not store or use gasoline or other flammable vapors and liquids in the vicinity of this or any other appliance.

- WHAT TO DO IF YOU SMELL GAS:

- Do not try to light any appliance.
- Do not touch any electrical switch; do not use any phone in your building.
- Immediately call your gas supplier from a neighbor's phone. Follow the gas supplier's instructions.
- If you cannot reach your gas supplier, call the fire department.

- Installation and service must be performed by a qualified installer, service agency, or the supplier.



APPLY SERIAL NUMBER LABEL FROM CARTON



WARNING

- This appliance is hot when operated and can cause severe burns if contacted.
- Any changes to this appliance or its control can be dangerous and are prohibited.
- Do not operate appliance before reading and understanding operating instructions. Failure to operate appliance according to operating instructions could cause fire or injury.
- Risk of fire or asphyxiation do not operate appliance with fixed glass removed.
- Do not connect 110 volts to the control valve.
- Risk of burns. The appliance should be turned off and cooled before servicing.
- Do not install damaged, incomplete or substitute components.
- Risk of cuts and abrasions. Wear protective gloves and safety glasses during installation. Sheet metal edges may be sharp.
- Children and adults should be alerted to the hazards of high surface temperature and should stay away to avoid burns or clothing ignition.
- Young children should be carefully supervised when they are in the same room as the appliance. Toddlers, young children, and others may be susceptible to accidental contact burns. A physical barrier is recommended if there are at risk individuals in the house. To restrict access to an appliance or stove, install an adjustable safety gate to keep toddlers, young children and other at risk individuals out of the room and away from hot surfaces.
- Clothing or other flammable material should not be placed on or near the appliance.
- Due to high temperatures, the appliance should be located out of traffic and away from furniture and draperies.
- Ensure you have incorporated adequate safety measure to protect infants/toddlers from touching hot surfaces.
- Even after the appliance is out, the glass and/or screen will remain hot for an extended period of time.
- Check with your local hearth specialty dealer for safety screens and hearth guards to protect children from hot surfaces. These screens and guards must be fastened to the floor.
- Any safety screen, guard or barrier removed for servicing the appliance, must be replaced prior to operating the appliance.
- The appliance is a vented gas-fired appliance. Do not burn wood or other materials in the appliance.
- The appliance area must be kept clear and free from combustible materials, gasoline and other flammable vapors and liquids.
- Under no circumstances should this appliance be modified.
- This appliance must not be connected to a chimney flue pipe serving a separate solid fuel burning appliance.
- Do not use this appliance if any part has been under water. Immediately call a qualified service technician to inspect the appliance and to replace any part of the control system and any gas control which has been under water.
- Do not operate the appliance with the glass door removed, cracked or broken. Replacement of the glass should be done by a licensed or qualified service person.
- Do not strike or slam shut the appliance glass door.
- When equipped with pressure relief doors, they must be kept closed while the appliance is operating to prevent exhaust fumes containing carbon monoxide, from entering into the home. Temperatures of the exhaust escaping through these openings can also cause the surrounding combustible materials to overheat and catch fire.
- Only doors / optional fronts certified with the unit are to be installed on the appliance.
- Keep the packaging material out of reach of children and dispose of the material in a safe manner. As with all plastic bags, these are not toys and should be kept away from children and infants.
- As with any combustion appliance, we recommend having your appliance regularly inspected and serviced as well as having a carbon monoxide detector installed in the same area to defend you and your family against carbon monoxide.
- Ensure clearances to combustibles are maintained when building a mantel or shelves above the appliance. Elevated temperatures on the wall or in the air above the appliance can cause melting, discoloration or damage to decorations, a T.V. or other electronic components.
- A barrier designed to reduce the risk of burns from the hot viewing glass is provided with this appliance and shall be installed.
- If the barrier becomes damaged, the barrier shall be replaced with the manufacturer's barrier for this appliance.
- Installation and repair should be done by a qualified service person. The appliance should be inspected before use and at least annually by a professional service person. More frequent cleaning may be required due to excessive lint from carpeting, bedding material, etc. It is imperative that control compartments, burners and circulating air passageways of the appliance be kept clean.

 WARNING: This product can expose you to chemicals including lead and lead compounds, which are known to the State of California to cause cancer, and chemicals including carbon monoxide, which are known to the State of California to cause birth defects or other reproductive harm. For more information, go to www.P65Warnings.ca.gov.

1.0	getting to know your appliance	5
1.1	control access	6
1.2	rating plate information	6
2.0	operating your appliance	7
2.1	on/off components	7
2.2	using your appliance	7
2.3	operating and lighting instructions	8
2.4	pilot on demand	9
2.4.1	connecting battery backup	10
2.4.2	turndown	11
3.0	remote control layout	12
3.1	general transmitter layout	12
3.2	temperature display	12
3.3	in the event of a battery failure	13
3.4	eFIRE Controller application	13
3.5	low battery	13
4.0	clearances around appliance	14
4.1	optional heat management system	15
5.0	maintenance	17
5.1	care of glass	17
5.2	care of plated parts	18
5.3	safety barrier removal/installation	18
5.4	firebox glass door removal	19
5.5	top and bottom door trim installation	19
6.0	replacement parts	20
7.0	accessories	21
8.0	troubleshooting	22
9.0	warranty	23

Before reading this manual, be sure you know which model of appliance that you have. This information will have been filled out by the installer on the following page and on the rating plate that is permanently attached to the appliance (see “rating plate information” section).

This manual is for the:

- **Altitude™ Series (A36 and A42 models)**

If required, more detailed technical information is included in the appliance installation manual.

The information throughout this manual is believed to be correct at the time of printing. Wolf Steel Ltd. reserves the right to change or modify any information within this manual at any time without notice.

Visit the Napoleon website for the most current version of your appliance’s manual.

Changes, other than editorial, are denoted by a vertical line in the margin.

This appliance is suitable for use with the Universal Heat Management system. THIS MANUAL **DOES NOT** include detailed information relating the optional system. Framing and finishing are NOT the same. For further details, refer to UHM instructions provided with the kit before starting installation.

welcome

congratulations!

Napoleon is proudly committed to your total home comfort. We are proud to say that our products continuously surpass industry standards and our inspiration is you! More than anything, we want you to feel confident in choosing Napoleon for your home. Our products are designed to provide that confidence and ensure that every Napoleon product is beyond compare.

Napoleon products are designed with superior components and materials assembled by trained craftsmen who take great pride in their work.

A barrier designed to reduce the risk of burns from the hot viewing glass is provided with the appliance for your safety. **This barrier must be installed.**

Your Napoleon appliance has been thoroughly inspected by a qualified technician before packaging to ensure that you, the customer, receives the quality product that you expect from Napoleon.

Dealer : Fill in your dealer information (or business card) and the appliance installation information below.

Dealer Information

Name of Dealer: _____

Dealer Location: _____

Dealer Phone: _____

Dealer E-mail: _____

Customer: _____

Customer Address: _____

Date of Installation: _____

Location of the appliance: _____

Installer: _____

Dealer: Business card location

Serial Number: _____

Model:

Natural Gas: A36NTE
 A42NTE

Propane: A36PTE
 A42PTE

Universal Heat Management Kit installed (Optional)

1.0 getting to know your appliance EN

The area above the appliance opening including the safety barrier, barrier frame and the surface of the wall can get very hot during operation and should never be touched until the appliance is off and completely cooled.

DANGER

HOT GLASS WILL CAUSE BURNS.

DO NOT TOUCH GLASS UNTIL COOLED.

NEVER ALLOW CHILDREN TO TOUCH GLASS.

A barrier designed to reduce the risk of burns from the hot viewing glass is provided with this appliance and shall be installed for the protection of children and other at-risk individuals.

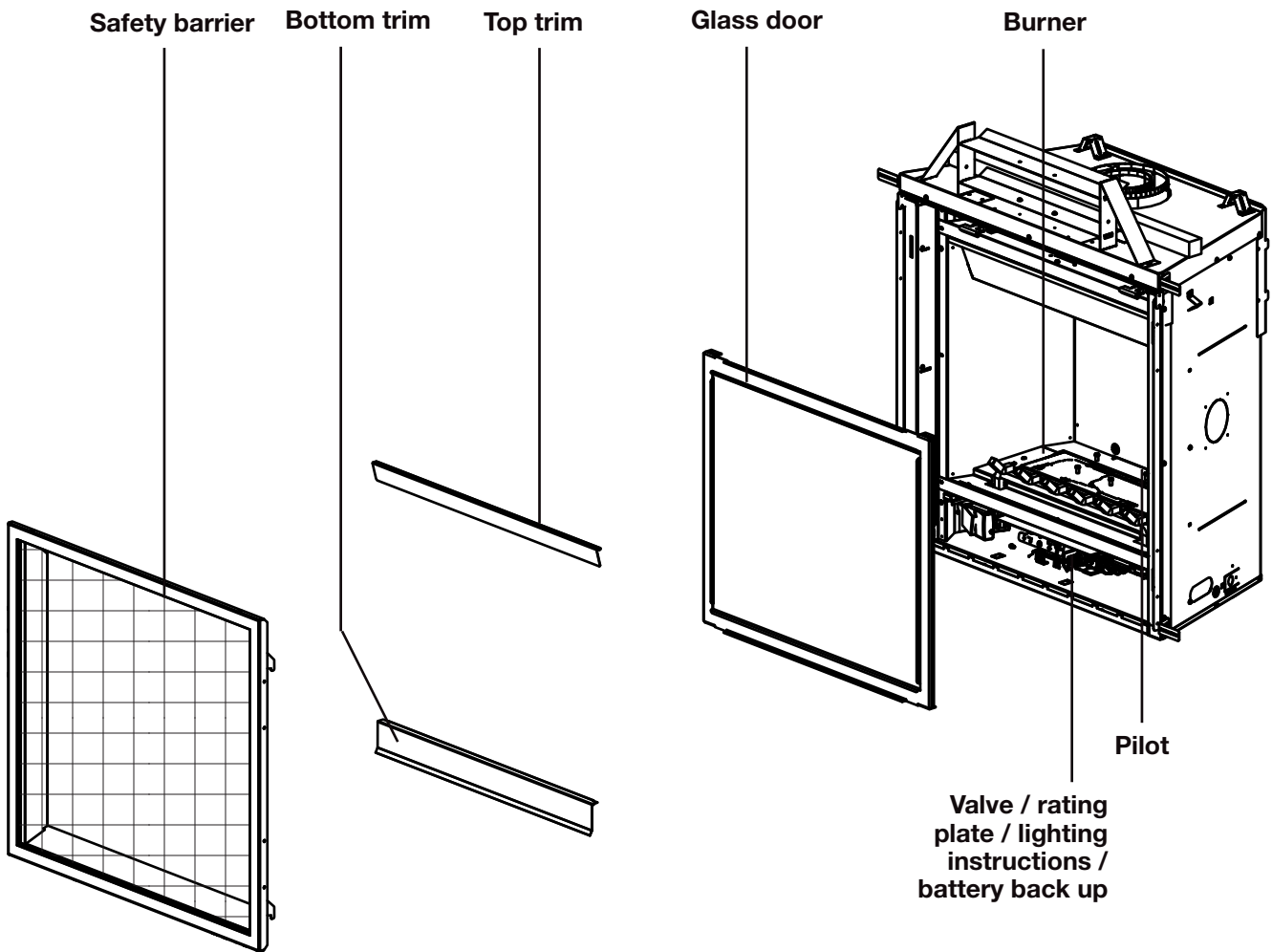

note:

Some features and locations may vary depending on the model.

getting to know your appliance

1.1 control access

Access to the control can be done by removing the safety barrier, glass door and door trims (see “maintenance” section for instructions on how to remove these components).

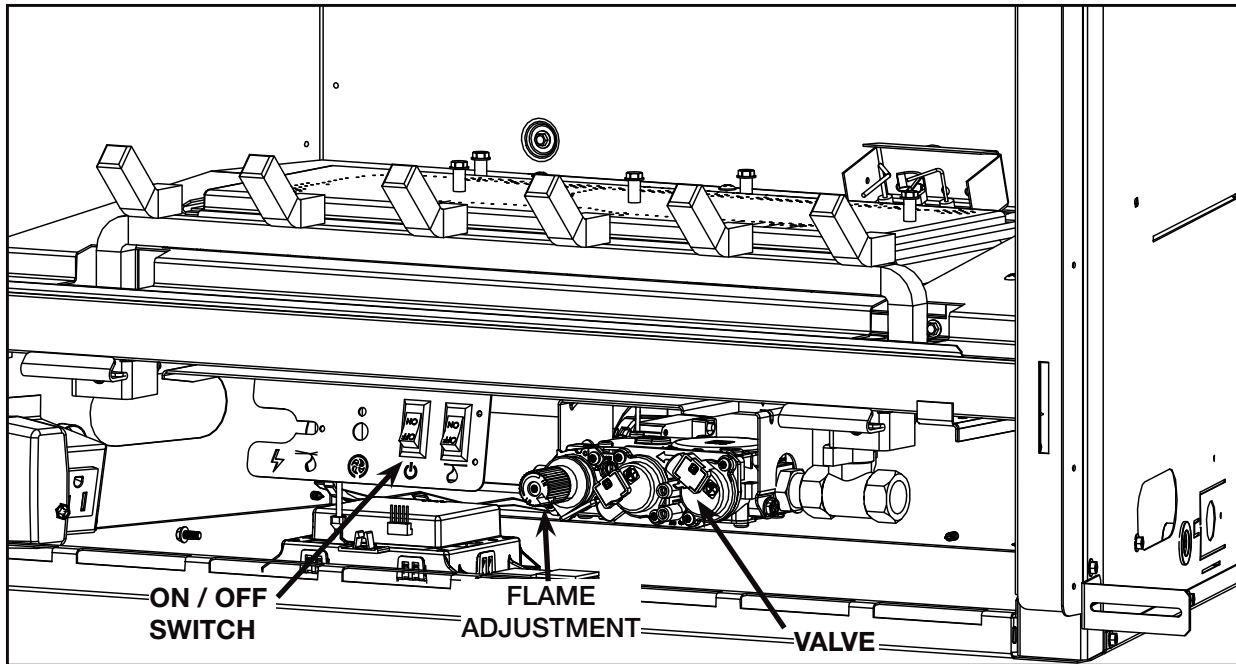

1.2 rating plate information

This illustration is for reference only. Refer to the rating plate on the appliance for accurate information.

Certified to Canadian and American National Standards: **CSA 2.22-XXXX / ANSI Z21.50-XXXX for Vented Decorative Gas Appliances**
 Certifié selon les normes Nationales Canadiennes et Américaines: **CSA 2.22-XXXX / ANSI Z21.50-XXXX pour les Appareils à gaz décoratif à évacuation**

Direct vent, vented gas fireplaces. Approved for bedroom, bathroom and bed-sitting room installation. Suitable for mobile home installation, if installed in accordance with the current standard CAN / CSA Z240MH Series gas equipped mobile homes in Canada, or, in the United States, the *Manufactured Home Construction and Safety Standard, Title 24 CFR, Part 3280*. When this US Standard is not applicable, use the *Standard for Fire Safety Criteria for Manufactured Home Installations, Sites and Communities, ANSI / NFPA 501A*. This appliance must be installed in accordance with local codes, if any; if none, follow the current ANSI Z223.1 or CSA B149. **For use with barrier WXXX-XXXX. Follow installation instructions.**
 Foyer à gaz ventilé. Homologué pour installation dans une chambre à coucher, une salle de bain et un studio. Apprôprié pour installation dans une maison mobile si son installation conforme aux exigences de la norme CAN / CSA Z240MH Série de maisons mobile équipées au gaz en vigueur au Canada, ou, aux États-Unis selon la norme 24 CFR, Part 3280, *Manufactured Home Construction and Safety Standard*. Dans le cas où cette norme d'États-Unis n'est pas pertinente, utiliser la norme NFPA 501A, *Fire Safety Criteria for Manufactured Home Installations, Sites and Communities*. Installer l'appareil selon les codes ou règlements locaux ou, en l'absence de tels règlements, selon les codes d'installation ANSI Z223.1 ou CSA B149 en vigueur. **Utiliser uniquement avec l'écran WXXX-XXXX. Suivre les instructions d'installation.**

9700539 (WSL) 4001658 (NAC) 4001657 (NGZ) 4001659 (WUSA)

MODEL / MODÈLE

<input type="checkbox"/> XXXX	<input type="checkbox"/> XXXX	<input type="checkbox"/> XXXX	<input type="checkbox"/> XXXX
<input type="checkbox"/> XXXX	<input type="checkbox"/> XXXX	<input type="checkbox"/> XXXX	<input type="checkbox"/> XXXX

Altitude 0-XXXXft (0-XXXXm) Elevation 0-XXXXft (0-XXXXm)

Input XX,XXX	XX,XXX	XX,XXX	XX,XXX
Reduced Input XX,XXX	XX,XXX	XX,XXX	XX,XXX
P4 XX,X%	XX,X%	XX,X%	XX,X%

Manifold Pressure: 3.5" w.c. (NG) **Manifold Pressure:** 10" w.c. (P)
Minimum Supply Pressure: 4.5" w.c. (NG) **Minimum Supply Pressure:** 11" w.c. (P)
Maximum Supply Pressure: 7" w.c. (NG) **Maximum Supply Pressure:** 13" w.c. (P)

Pression au Collecteur: 3.5" d'une colonne d'eau (GN) **Pression au Collecteur:** 10" d'une colonne d'eau (P)
Pression d'Alimentation Min.: 4.5" d'une colonne d'eau (GN) **Pression d'Alimentation Min.:** 11" d'une colonne d'eau (P)
Pression d'Alimentation Max.: 7" ** d'une colonne d'eau (GN) **Pression d'Alimentation Max.:** 13" ** d'une colonne d'eau (P)
 ** Maximum inlet pressure not to exceed 13".

Minimum clearance to combustible materials: **Dégagements minimaux des matériaux combustibles:**
 Top, sides & back: per standoff spacers for framing and finishing materials. For non-combustible framing and finishing materials, see installation manual.
 Dessus, côtés et arrière: selon les espacements de dégagements pour les matériaux d'ossature selon le manuel du propriétaire pour les matériaux de finition.

Top X" Dessus X"
 Floor X" Plancher X"
 Sides X" Côtés X"
 Back X" Arrière X"

Vent top X" Dessus du conduit d'évent X"
 Vent sides & bottom X" Côtés et dessous du conduit d'évent X"
 Recessed depth X" Profondeur d'encastrement une face X"

*** Mantlet X" from appliance opening
 *** Maximum horizontal extension:
 X". See installation manual for greater extensions, minimum vent lengths and maximum vent lengths.
 Electrical rating: 115V, 60HZ. Less than 12 amperes.
 Spécifications électriques: 115V, 60HZ. Moins de 12 ampères.



REFERENCE# 161746

VENTED DECORATIVE GAS APPLIANCE: NOT A SOURCE OF HEAT, NOT INTENDED FOR USE AS A HEATING APPLIANCE, NOT FOR USE WITH SOLID FUEL.
APPAREIL À GAZ DÉCORATIF À ÉVACUATION: N'EST PAS UNE SOURCE DE CHALEUR; N'EST PAS DESTINÉ À ÊTRE UTILISÉ COMME UN APPAREIL DE CHAUFFAGE; NE CONVIENT PAS AUX COMBUSTIBLES SOLIDES.

FOR USE WITH GLASS DOORS CERTIFIED WITH THIS APPLIANCE ONLY. POUR UTILISATION UNIQUEMENT AVEC LES PORTES EN VERRE CERTIFIÉES AVEC L'APPAREIL.

For natural gas when equipped with No. XX drill size orifice.
 For propane when equipped with No. XX drill size orifice.
 Convient au gaz naturel quand l'appareil est muni d'un injecteur de diamètre no. XX.
 Convient au propane quand l'appareil est muni d'un injecteur de diamètre no. XX.

WARNING: Do not add any material to the appliance which will come in contact with the flames, other than that supplied by the manufacturer with the appliance.
AVERTISSEMENT: N'ajoutez pas à cet appareil aucun matériau devant entretien contact avec les flammes autre que celui qui est fourni avec cet appareil par le fabricant.
 The appliance must be vented using the appropriate Napoleon vent kits. See installation manual for venting specifications. Proper reinstallation and resealing is necessary after servicing the vent-air intake system.
 L'appareil doit être ventilé à l'aide de l'ensemble d'évacuation propre à Napoleon. Référez au manuel d'installation pour les spécifications d'évacuation. Il est nécessaire de bien réinstaller et resceller l'évacuation après avoir exécuté l'entretien du système de prise d'air.

Serial Number / N° de Série: XXXX

W385-XXXX

note:

The rating plate must remain with the appliance at all times. It must not be removed.

2.1 on/off components

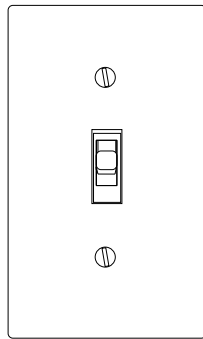

Wall Switch
(Not supplied)

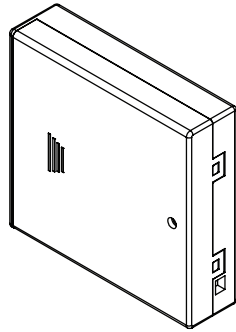

Battery Backup Housing / Wire
(Supplied)



Receiver
(Optional)

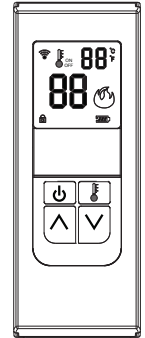

Remote Control
(Optional)

2.2 using your appliance

When operating your appliance for the first time, there is a required burn-in process that cures materials used to manufacture the appliance that may emit both vapors and an odor. These are normal when operating a new appliance for the first time. Ensure adequate air circulation is provided during burn-in process, if this was not completed by the installer during installation.

To turn the appliance on:

- A. Remove the safety barrier, door trims and firebox glass door.
- B. Turn the appliance on using the on/off switch, see “control access” section.
- C. The pilot will spark, lighting it, and then the burner. The spark period will last 60 seconds, or until the pilot has lit.
- D. When used for the first time, if the burn-in process was not completed by the installer; run appliance continuously for minimum 4 hours (burn-in).
- E. Turn the appliance off. Wait until appliance is completely cool before moving to the next step.
- F. Clean firebox glass door (see “maintenance” section). Replace firebox glass door, door trims and safety barrier.

To turn the appliance on using the optional remote:

- A. Turn the remote on.
- B. After 3-5 seconds, the control will start a spark at the pilot, light the pilot and then the burner. The spark period will last 60 seconds, or until the pilot has lit.
- C. When used for the first time, if the burn-in process was not completed by the installer; run appliance continuously for minimum 4 hours (burn-in).
- D. Turn the appliance off. Wait until appliance is completely cool before moving to the next step.
- E. Remove the safety barrier, door trims and firebox glass door. Clean firebox glass door (see “maintenance” section). Replace firebox glass door, door trims and safety barrier.

For more detailed information, see your installation manual or contact your authorized dealer.

operating your appliance

2.3 operating and light instructions

! WARNING

- If you do not follow these instructions exactly, a fire or explosion may result causing property damage, personal injury, or loss of life.
- If applicable, always light the pilot whether for the first time or if the gas supply has run out with the glass door opened or removed.

Ensure that a continuous gas flow is at the burner before installing the door. When lit for the first time, the appliance will emit an odor for a few hours. This is a normal temporary condition caused by the “burn-in” of paints and lubricants used in the manufacturing process and will not occur again. After extended periods of non-operation, such as, following a vacation or warm weather season, the appliance may emit a slight odor for a few hours. This is caused by dust particules in the heat exchanger burning off. In both cases, open a window to sufficiently ventilate the room.

FOR YOUR SAFETY READ BEFORE LIGHTING

- Do not turn on if children or other at risk individuals are near the appliance.
- This appliance is equipped with an ignition device which automatically lights the pilot. Do not try to light the pilot by hand.
- Before operating, smell all around the appliance area for gas and next to the floor because some gas is heavier than air and will settle on the floor.
- Do not use this appliance if any part has been under water. Immediately call a qualified service technician to inspect the appliance and replace any part of the control system and any gas control which has been underwater.

WHAT TO DO IF YOU SMELL GAS

- Turn off all gas to the appliance.
- Open windows.
- Do not try to light any appliance.
- Do not touch any electric switch; do not use any phone in your building
- Immediately call your gas supplier from a neighbour's phone. Follow the gas supplier's instructions.
- If you cannot reach your gas supplier, call the fire department.

LIGHTING INSTRUCTIONS

note:

This appliance is equipped with an ignition device which automatically lights the pilot. Do not try to light the pilot by hand.

- Stop! Read the above safety information on this label.
- Remove batteries from the transmitter and set thermostat to lowest setting, if equipped.
- Turn off all electrical power to the appliance.
- Open the glass door, if equipped.
- Turn the manual shut-off valve clockwise to the “OFF” position. (Shut-off valve is located on the flex connector).
- Wait five (5) minutes to clear out any gas. If you smell gas including near the floor, **STOP!** Follow the instructions above in the “WHAT TO DO IF YOU SMELL GAS” section. If you don't smell gas; close the glass door and go to the next step.
- Turn the manual shut-off valve counter clockwise to the “ON” position.
- Turn on all electrical power to the appliance and re-install the batteries into the transmitter. Set thermostat to desired setting, if equipped.
- Turn on the remote wall switch to the appliance.
- If the appliance will not operate, follow instructions “TO TURN OFF GAS” and call your service technician or gas supplier.

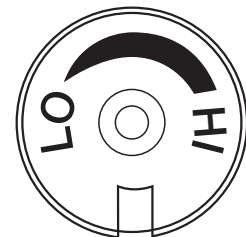
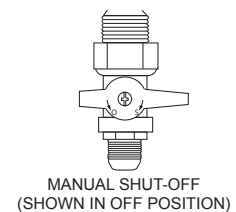

TO TURN OFF GAS

- Set thermostat to lowest setting, if equipped.
- Turn off the remote wall switch to the appliance.
- Turn off all electric power to the appliance if service is to be performed.
- Turn manual shutoff valve clockwise to the “OFF” position. Do not force.

2.4 pilot on demand

This appliance is equipped with an “On Demand” intermittent pilot ignition system (IPI) which also includes a continuous pilot ignition (CPI) mode with an integrated seven day timer. This system minimizes your appliance's carbon footprint as well as reducing its annual fuel consumption and operating costs.

In IPI mode, the pilot will ignite prior to the main burner, when the appliance is turned on using a switch, remote or from a call for heat with the thermostat (if equipped). Once the appliance is turned off (or the call for heat is satisfied), the main burner and pilot flame will shut down.

The continuous (CPI) mode is intended to enhance the performance of the appliance during the startup phase in colder climates and extreme weather by keeping the system warm when the main burner is not in use. However, the timer feature provides the convenience that the appliance automatically switches off the pilot when the appliance has not been used for seven days to save unnecessary fuel consumption.

When the CPI function is turned on, the pilot will remain on after the main burner is turned off. A timer will then begin the countdown for approximately seven days before shutting off the pilot if the appliance is not used. This countdown will reset anytime the appliance main burner is used. Therefore, if the appliance is regularly used day to day, the pilot will remain on. However, this system does not require the user to remember to turn the pilot off as summer approaches and avoids unnecessary fuel consumption while still readily turned back on when the cold weather returns.

Your appliance may be equipped with an ACS or remote control device (Fig. 1) which enables you to select IPI or CPI modes.

If your appliance is equipped with an ACS switch, it has the option to change modes:

Fig. 2: Flipping the switch ON turns on the continuous pilot with timer and flipping the switch OFF turns on the intermittent pilot ignition.

Fig. 3: If installed with the blue wire facing up, flipping the switch UP turns on the continuous pilot with timer and flipping the switch DOWN turns on the intermittent pilot ignition. If installed with the white wire facing up, the opposite is true.

If your appliance is equipped with a remote control device capable of selecting IPI / CPI modes, refer to remote operating instructions.

In order to start your pilot, turning the main burner on with the switch, remote or thermostat and then turning it off will reactivate the continuous pilot mode and reset the seven day timer.

For further information, refer to www.napoleon.com/pilotondemand



(Fig. 1)

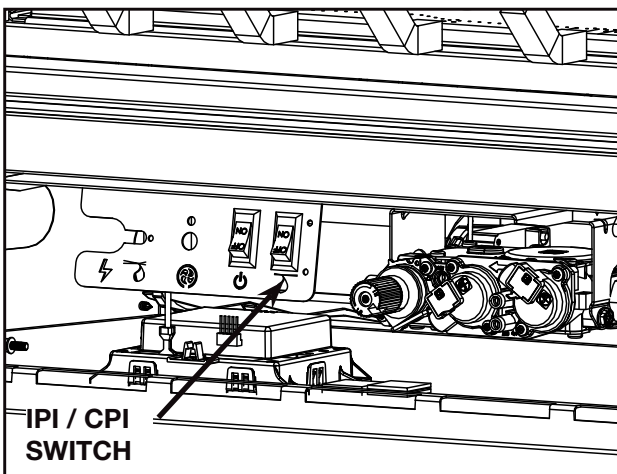

(Fig. 2)

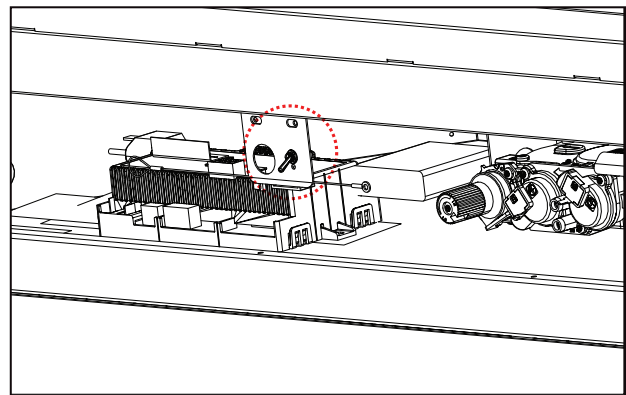

(Fig. 3)

Control board illustrated may appear different than the one in your model.

operating your appliance

2.4.1 connecting battery backup

! WARNING

- Ensure the gas and electrical power to the appliance is turned off.
- Appliance may be hot, do not service until the appliance has cooled.

note:

In the event of a power failure, your appliance can be operated using the battery backup.

- Before beginning installation, turn off the gas and disconnect the electrical power supply from the appliance.
- Remove the safety screen to easily access the control compartment.
- Locate the control board under the firebox.
- Unplug the USB power supply going to the control board and replace it with the battery backup wire and housing provided.
- Reinstall the safety screen. The safety screen must be installed at all times during the appliance operation.
- Turn the gas and electrical power back on to begin operating the appliance.

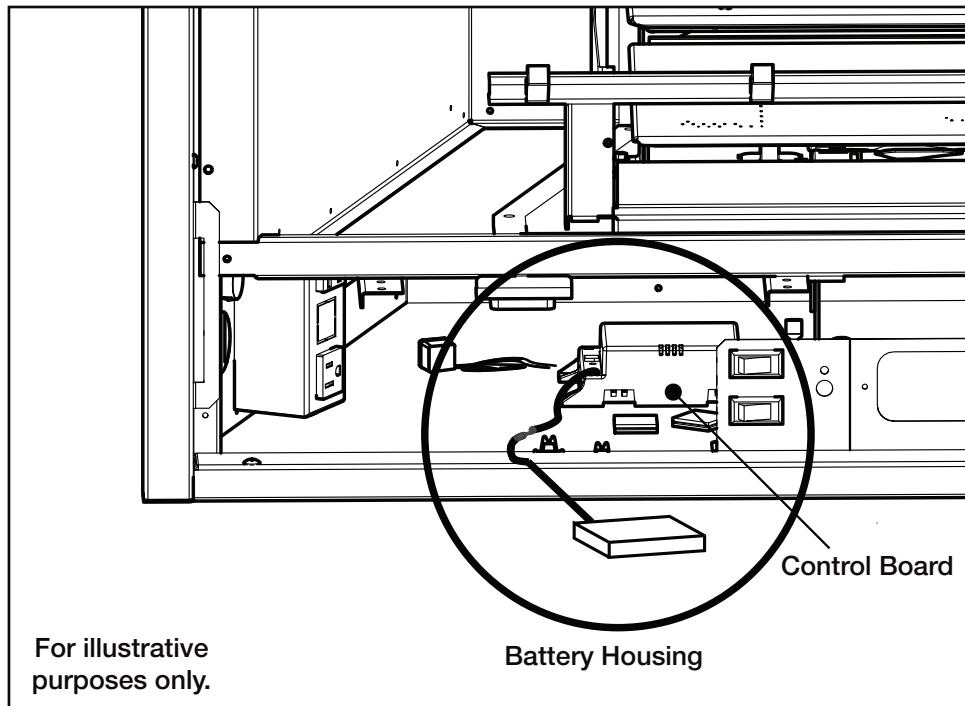

Batteries must be disposed of according to the local laws and regulations. Some batteries may be recycled, and may be accepted for disposal at your local recycling center. Check with your municipality for recycling instructions.

2.4.2 turndown

Manual adjustments to your fireplace must only be made when the appliance is off and complete cool. Allow safety barrier to cool before making adjustment.

The A36/42 models are equipped with a manual gas control knob (located on the valve) that adjusts the flame height to suit your preference. To access the gas control knob, remove your safety barrier, control cover and door trim (see “maintenance” section for instructions on how to remove these components).

Use only your hand to turn the gas control knob (never use tools). If the knob will not turn by hand, do **not** try to repair it. Contact a qualified technician.

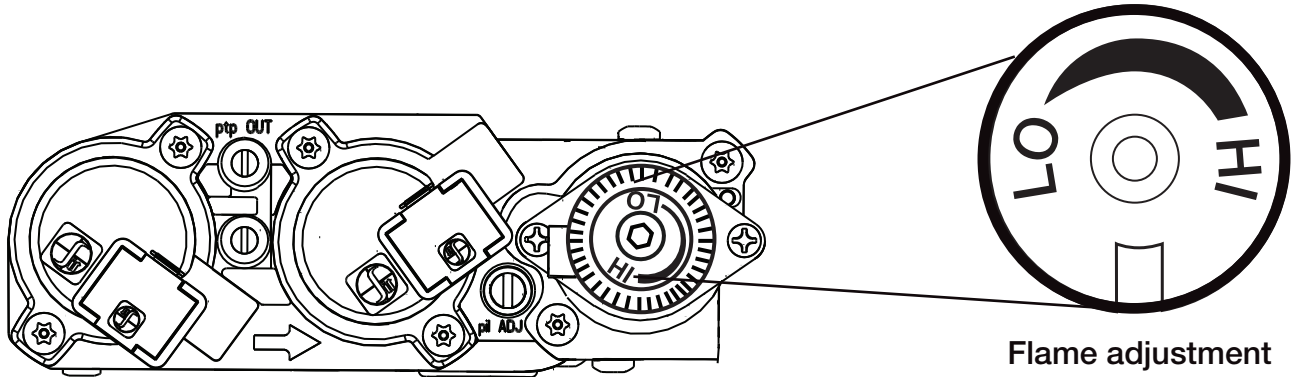

3.0 remote control layout

3.1 general transmitter layout

note:

The remote control is optional for the A36 and A42 models.

The receiver switch must be in the REMOTE position for the transmitter to function. This remote system operates using radio frequency signals sent by the transmitter to the receiver. It is recommended that the distance between the transmitter and receiver never exceeds 20' and 10' if the receiver is located within the fireplace's outer or inner cavity surrounding an insert. Low batteries will also affect operational distance.

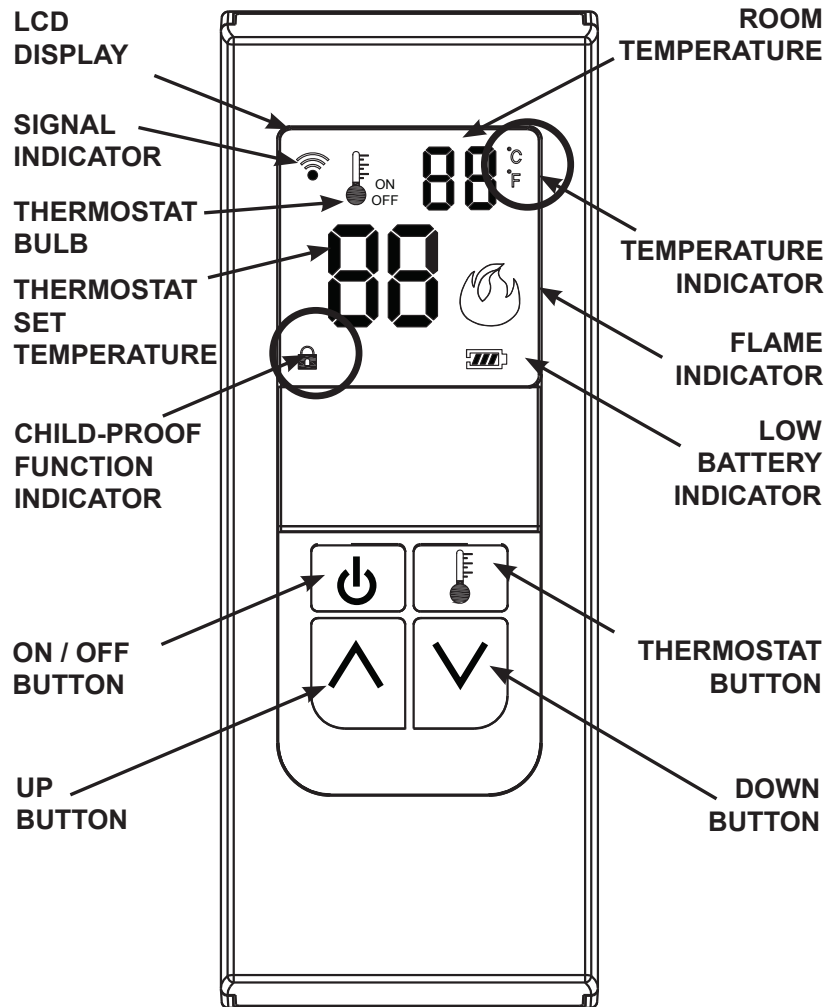

3.2 temperature display

Remove the battery cover on the back of the transmitter to expose the °C / °F dip switch. Move the dip switch to your desired temperature mode. Selected temperature mode will appear in the top right corner beside the room temperature.

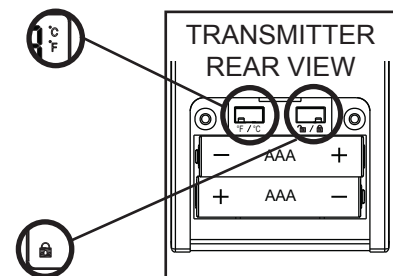

3.3 in the event of a battery failure

If the receiver batteries fail, the appliance will no longer turn on or off. To operate the appliance in the event of a battery failure, the slide switch located on the receiver may be switched to the “ON” position to operate the appliance.

3.4 eFIRE Controller application

Napoleon’s eFIRE application will revolutionize the way you use your fireplace! We have cracked the code and present to you the first fireplace to be controlled by Bluetooth technology, using an intuitive app on your mobile device.

When fully equipped (if applicable), the eFIRE application allows you to select from a multitude of colors to suit your mood or décor simply by scrolling through the color wheel. Additionally, Napoleon’s eFIRE application allows you to control many other functions of your fireplace, including on/off, flame height, light feature, blower, and a timer to create a schedule for your fireplace that works for you.

Using the instructions on the eFIRE Controller application website <http://napoleon.com/efire>, install the application and enjoy the features the eFIRE Controller application has to offer. *

* Visit the website or contact your authorized dealer for appliance-specific information and/or frequently asked questions regarding features and products available with the eFIRE Controller application.

note:

The remote control is considered the master control for the appliance and can always be used to turn the appliance off (ex. the eFIRE Controller application user, in control of the appliance, leaves the home).

3.5 low battery

The life span of the remote batteries depends on various factors: quality of the batteries, the number of ignitions, etc.

When the transmitter batteries are low, a battery icon will appear on the LCD display before all battery power is lost. When the batteries are replaced, this icon will disappear.

When the receiver batteries are low, no “beep” will be emitted from the receiver when it receives an **on/off** command. This is an alert for the receiver that there’s low battery.

When the batteries are replaced the “beep” will be emitted from the receiver when the **on/off key** is pressed.

If the batteries of the receiver or transmitter are low, the appliance can be turned on manually by sliding the three position slider switch on the receiver to the **on** position. This will bypass the remote control feature and the appliance main burner will come on if the gas valve is in the **on** position.

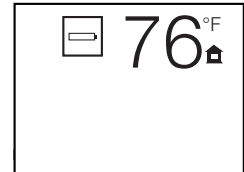

4.0 clearances around appliance

! WARNING

- Your appliance, gas/electrical connections, venting and various key components are hidden behind the wall. It is critical that no screws penetrate these components. Failure to follow instructions may cause improper operation, damage, personal injury or fire. Always use a stud finder and only screw into studs.

Without making adequate provisions to account for the heat, the temperatures above the appliance will be hot, making it unsuitable for mounting a TV or other objects sensitive to heat without risk of damage.

Installing a mantel between this appliance and electronics or other materials that may be sensitive to heat will reduce the effect of direct heat on them.

The size and material of the mantel will affect the allowable clearance above your appliance and incorrect placement could become a fire hazard. Consult your installation manual and/or authorized dealer for more information before mounting a mantel, a shelf or any other object above your appliance.

Your appliance, gas/electrical connections and vent are hidden directly behind the finished wall. Great care should be taken to avoid screwing or nailing into these components. Always use a stud finder to determine stud location and only screw into studs.

Do not screw into the area around the appliance opening as some of your appliance may be hidden behind the finished wall. Refer to your installation manual and/or contact your local dealer for more information.

! WARNING

The area above an appliance gets hot. Combustible objects or materials must never be placed in this area. For minimum clearances, refer to installation manual or your authorized dealer.

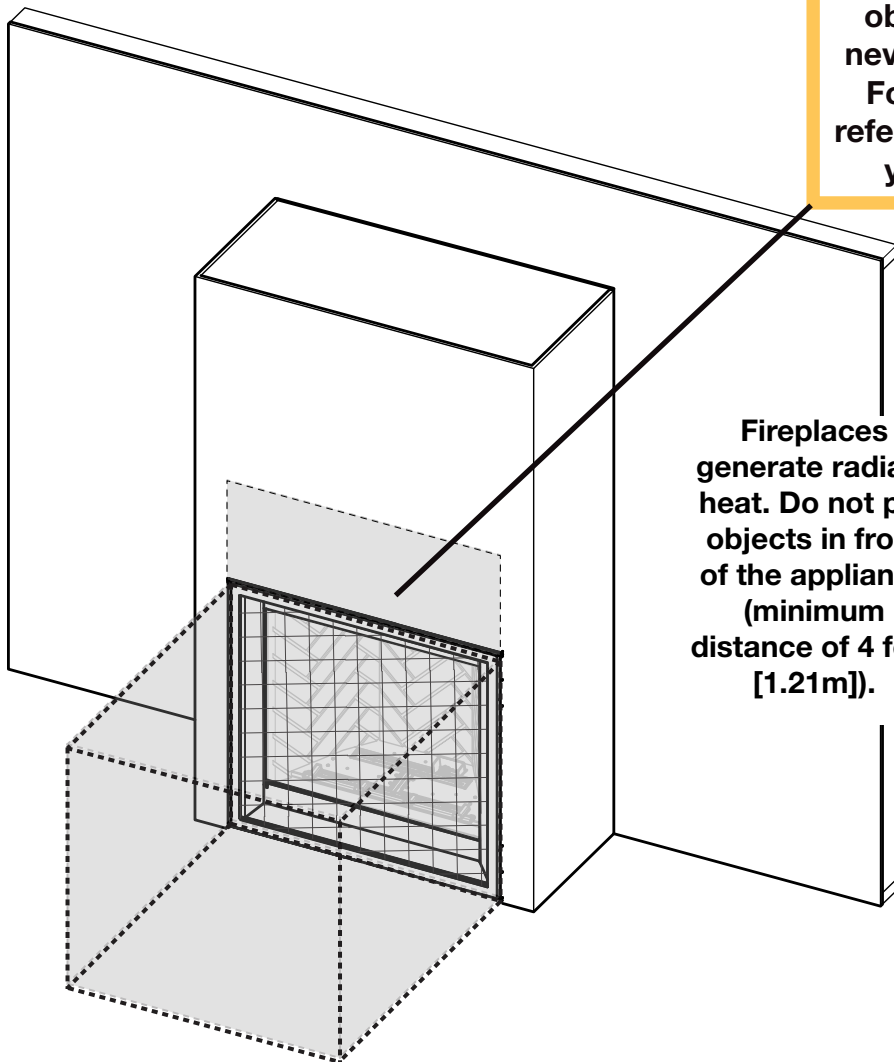

Fireplaces generate radiant heat. Do not put objects in front of the appliance (minimum distance of 4 feet [1.21m]).

4.1 optional heat management system

The Universal Heat Management system is an optional gravity vent kit that allows you to manage the heat produced by the appliance at and around the fireplace.

We recommend installing the Universal Heat Management kit during the installation of the appliance **BEFORE** the appliance venting and gas are installed.

For more information, contact your local authorized dealer.

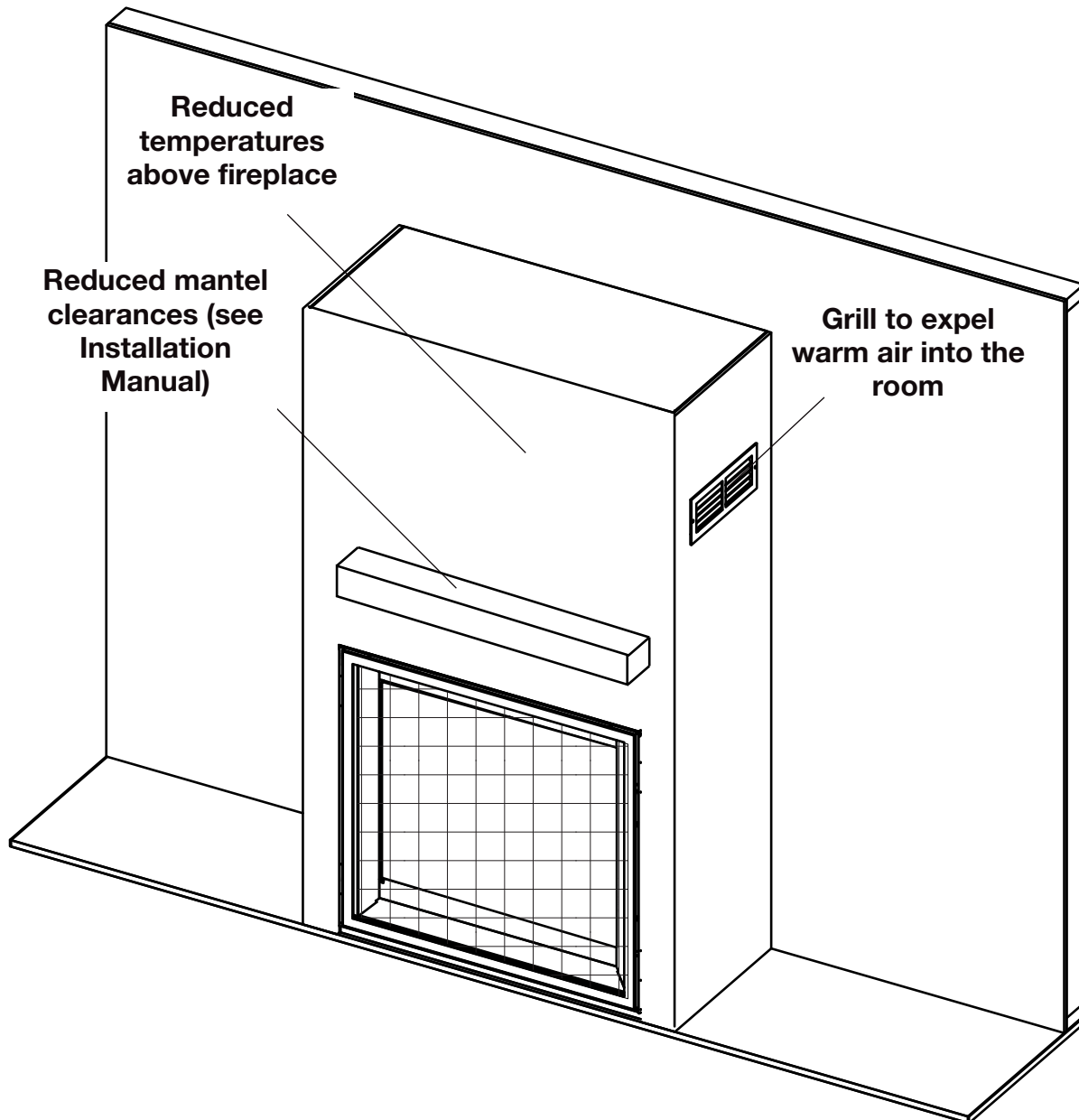

clearances around fireplace

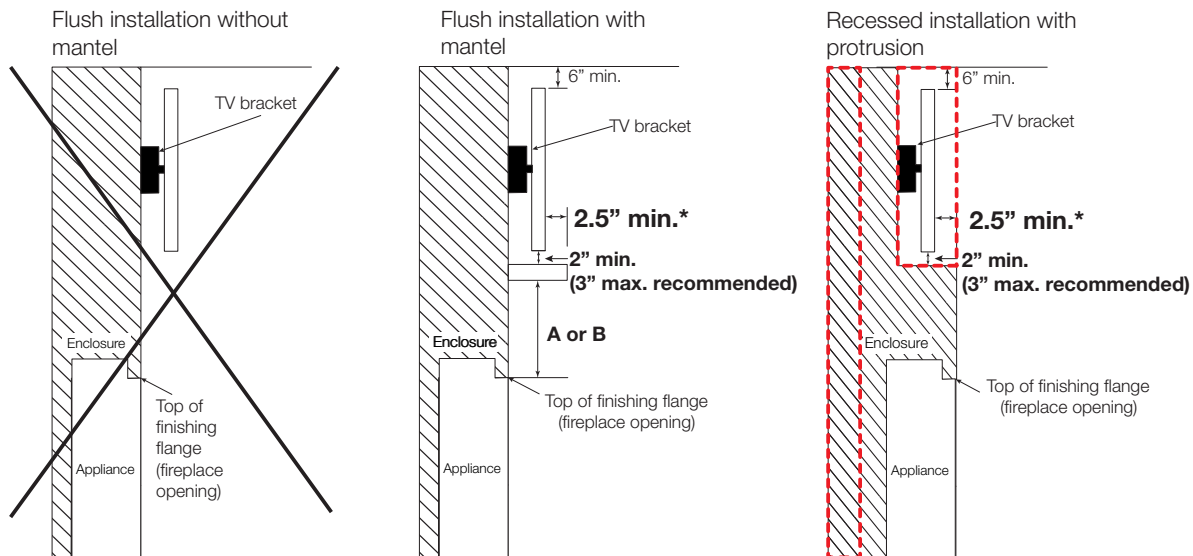

 The volume of air must be added to the enclosure to accommodate the recessed area.

Partially recessed installation with mantel

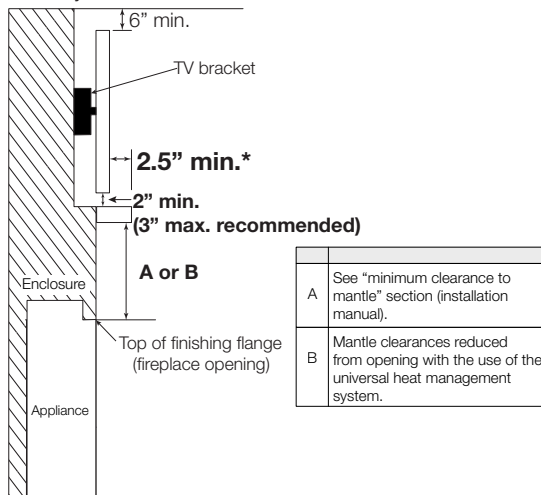

note:

- These are recommended minimum clearances only and are supplied in good faith and not a guarantee of compliance with TV manufacturers' maximum allowable operating temperatures. Always comply with TV manufacturers' requirements.
- **Electronic appliance temperatures must be validated at the time of installation** as air flow characteristics within the room can vary and maximum acceptable operating temperatures can vary from appliance to appliance. Electronic appliances cannot be used where the electronic appliance temperature exceeds the manufacturer's maximum allowable operating temperatures (see electronic appliance manufacturer's specifications). **Operating a television above the manufacturer's maximum allowable operating temperature will result in premature failure.**
- Mantel height and depth must conform to mantel clearance requirements specified in this manual, see "minimum clearance to combustible mantel" section in installation manual.
- Electronic appliance temperatures may be further reduced by increasing the horizontal distance between the front of the electronic appliance and the front edge of the mantel or by increasing dimension "A" or "B". However, increasing the gap between the top of the mantel and the bottom of the electronic appliance beyond the maximum recommended figure, typically results in higher temperatures. Minimum clearance between the mantel and bottom of the electronic appliance should be maintained to allow air circulation below and behind the electronic appliance.

! WARNING

- Turn off the gas and electrical power before servicing the appliance.
- Appliance may be hot. Do not service until appliance has cooled.
- **For qualified technicians only:**
- Label all wires prior to disconnection when servicing controls. Wiring errors can cause improper and dangerous operation. Verify proper operation after servicing.
- This appliance and its venting system should be inspected before use and at least annually by a qualified service person.
- The flow of combustion and ventilation air must not be obstructed.

DOS

- Clean your safety barrier regularly to prevent the build up of excessive lint/dust from carpeting, pet hair, etc. Simply vacuum using the brush attachment.
- Always use ammonia-free glass cleaners.
- Service your appliance annually and/or as required. Service must be conducted by a qualified technician.
- Keep your appliance area clear and free of combustible materials, gasoline, or other flammable vapors and liquids.
- Check to see that the burner ignites completely on all openings when turned on. A 5 to 10 second total light-up period is satisfactory. Service as required.

DON'TS

- Attempt to service the electrical or gas components. Contact a qualified technician.
- Use excessive force.
- Use abrasive cleaners on glass.
- Paint the pilot assembly.
- Place objects too close to the appliance opening.

note:

For any questions and/or concerns regarding your appliance, maintenance and service, please contact your authorized dealer.

5.1 care of glass**! WARNING**

- Do not clean glass when hot! Do not use abrasive cleaners to clean glass.

Buff lightly with a clean dry soft cloth to remove accumulated dust or fingerprints. Clean both sides of the glass after the first 4 hours of operation with an ammonia-free glass cleaner.

note:

Vinegar-based glass cleaners have demonstrated an ability to provide a clean, streak free glass surface.

Thereafter, clean as required. If the glass is not kept clean permanent discoloration and / or blemishes may result. Contact your local authorized dealer / distributor for complete cleaning instructions.

Razor blades, steel wool, or other metallic objects must not be used on both surfaces of the glass. Doing so can remove a thin layer of metal from the razor blades, steel wool, or other metallic objects that may then be deposited onto the coating. This can result in a discoloured stain or scratch-like mark. More importantly, this can scratch the glass surface, thereby reducing its strength.

Do not operate the appliance with broken glass, as leakage of flue gases may result.

Contact your local authorized dealer / distributor for complete cleaning instructions.

If the glass should ever crack or break while the fire is burning, do not open the door until the fire is out. Do not operate the appliance until the glass has been replaced. Contact you local authorized dealer / distributor for replacement parts. **DO NOT SUBSTITUTE MATERIALS.**

Replacement glass/frame assembly shall be replaced as a complete unit as supplied by the appliance manufacturer.

This appliance is factory equipped with 5mm ceramic glass. Use only replacement parts as supplied by the appliance manufacturer. **DO NOT SUBSTITUTE MATERIALS.**

maintenance

5.2 care of plated parts

If the appliance is equipped with plated parts, you must clean fingerprints or other marks from the plated surfaces before operating the appliance for the first time. Use an ammonia-free or vinegar-based cleaner and a towel to clean. If not cleaned properly before operating for the first time, the marks can cause permanent blemishes on the plating. After the plating is cured, the fingerprints and oils will not affect the finish and little maintenance is required, just wipe clean as needed. Prolonged high temperature burning with the door ajar may cause discolouration on plated parts.

note:

The protective wrap on plated parts is best removed when the assembly is at room temperature but this can be improved if the assembly is warmed (i.e. using a hair dryer or similar heat source).

5.3 safety barrier removal/installation

! WARNING

- Glass may be hot. Do not touch glass until cooled.
- If equipped with door latches that are part of a safety system, they must be properly engaged. Do not operate the appliance with latches disengaged.
- Facing and/or finishing materials must not interfere with air flow through air openings, louvre openings, operation of louvres, or doors/access for service. Observe all clearances when applying combustible materials.
- Before door is removed, turn the appliance off and wait until appliance is cool to the touch. Doors are heavy and fragile so handle with care.

A barrier designed to reduce the risk of burns from the hot viewing glass is provided with the appliance and must be installed.

Before the glass door can be removed, the safety screen must be removed. Lift the safety screen off the slots, tilt the top forward and remove from the appliance.

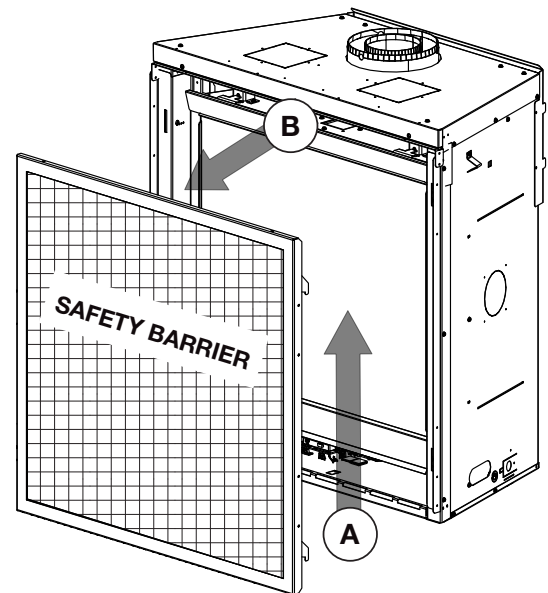

5.4 firebox glass door removal

Leave a hand on the glass door during entire door removal. The glass door is secured to the firebox with four spring latches. Pull the handles of the latches forward (door latch tool supplied in manual baggie), then lift the latches out from the door frame to release the door. Next, pivot the door forward until the top edge clears the front of the appliance. Carefully grip the sides of the door lifting it off the appliance.

note:

These spring latches make up the spring relief system for the appliance. Ensure the door opens freely and closes sealed.

note:

When mounting the door, ensure there is equal space on both the left and the right side. This allows for easy installation of the front.

Reverse these steps to reinstall the door. Ensure safety screen is installed correctly.

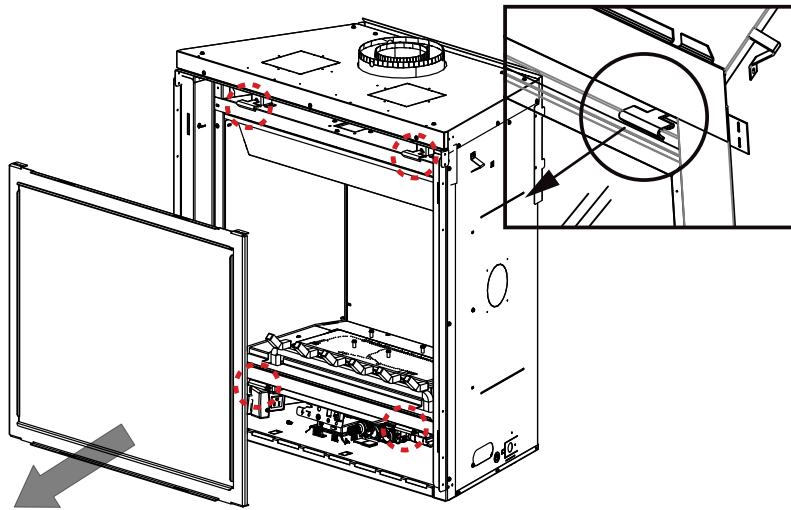

5.5 top and bottom door trim installation

This appliance is shipped with a top and bottom door trim packaged separately from the appliance.

Both trims **MUST** be installed. See illustration.

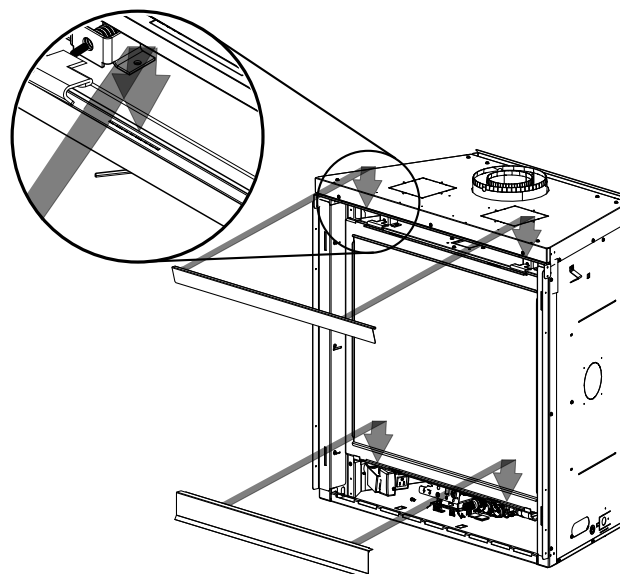

6.0 replacement parts

WARNING

- Failure to position the parts in accordance with this manual or failure to use only parts specifically approved with this appliance may result in property damage or personal injury.

Contact your dealer for questions concerning prices and policies on replacement parts. Normally, all parts can be ordered through your Authorized dealer / distributor.

For warranty replacement parts, a photocopy of the original invoice will be required to honour the claim.

When ordering replacement parts always give the following information:

- Model & Serial Number of appliance
- Installation date of appliance
- Part number
- Description of part
- Finish

Parts, part numbers, and availability are subject to change without notice.

Parts identified as stocked will be delivered within 2 to 5 business days for most delivery destinations.

Parts not identified as stocked will be delivered within a 2 to 4 week period, for most cases.

Parts identified as 'SO' are special order and can take up to 90 days for delivery.

Consult your installation manual for replacement parts.

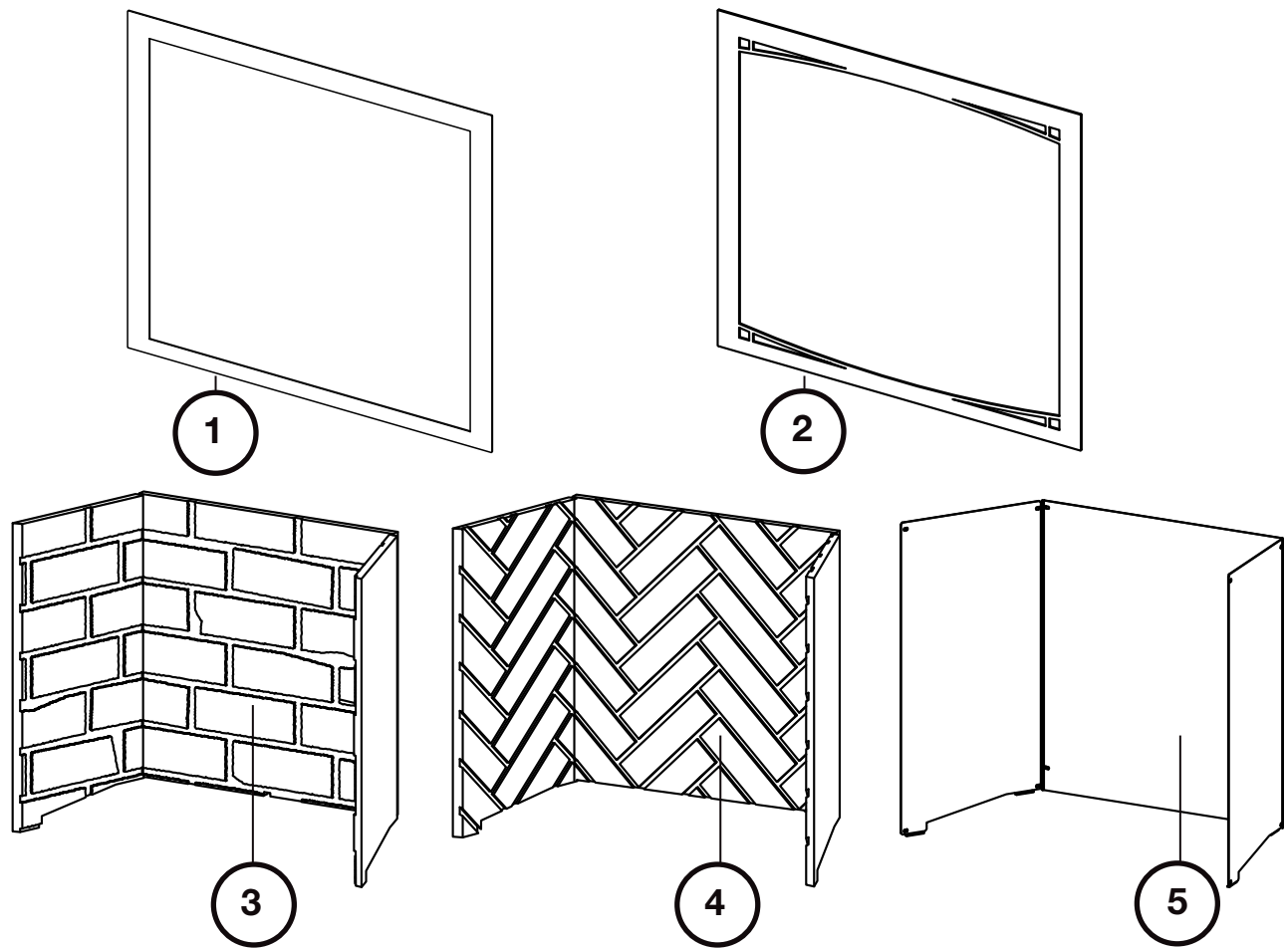

Ref.	Part Number	Description	Stocked
1	FTA36BK/CH/CP/GM	Finishing Trim (Black / Charcoal / Copper / Gunmetal)	
1	FTA42BK/CH/CP/GM	Finishing Trim (Black / Charcoal / Copper / Gunmetal)	
2	ZAX36BK/CH	Zen Front (Black / Charcoal)	
2	ZAX42BK/CH	Zen Front (Black / Charcoal)	
3	DBPA36NS/OS/WS	Standard Decorative Brick Panels (Newport / Old Town Red / Westminster)	
3	DBPA42NS/OS/WS	Standard Decorative Brick Panels (Newport / Old Town Red / Westminster)	
4	DBPA36WH/OH	Herringbone Decorative Brick Panels (Westminster / Old Town Red)	
4	DBPA42WH/OH	Herringbone Decorative Brick Panels (Westminster / Old Town Red)	
5	PRPA36	Porcelain Reflective Panels	
5	PRPA42	Porcelain Reflective Panels	

*Parts not illustrated

8.0 troubleshooting

symptom	problem	test solution
Flame is a blue, lazy, transparent flame	Blockage in vent.	- Remove blockage. In really cold conditions, ice buildup may occur on the terminal and should be removed as required.
White / grey film forms on glass.	Sulphur from fuel is being deposited on glass, logs, or surfaces.	- Clean the glass with a recommended gas fireplace glass cleaner. DO NOT CLEAN GLASS WHEN HOT. - If sulphur deposits are not cleaned off regularly, the glass may become permanently marked.
Exhaust fumes smelled in room, headaches.	Appliance may be leaking exhaust fumes into the room.	- Check firebox glass door was properly reinstalled after cleaning - If not rectified, turn off appliance. Contact a qualified technician.
Pilot will not light. Makes noise with no spark at pilot burner. (EI only)	No signal from remote with no pilot ignition.	- Reprogram receiver code. - Replace battery holder (including switch), if applicable.
Pilot sparks but will not light.	Gas supply.	- Contact a qualified technician.
	Out of propane gas.	- Fill the tank.
	Remote control (if equipped).	- Follow reprogramming instructions for specific remote installed with your appliance. - Replace remote control.
Battery holder (including switch) is in "off" position; burner comes on.	Battery holder (including wall switch) mounted upside down.	- Reverse.
	Battery holder (including switch) and/or wire is grounding.	- Replace. - Check for ground (short); repair ground or replace wire.
	Faulty wire	- Replace.
Remote control and/or battery holder (including switch) is not functioning properly.	Remote control lights but no spark or flame. (Remote is locked out).	- Reset by turning power source off then on.
	Battery holder (including switch) or remote has low battery.	- Replace batteries.
	Error with synchronizing.	- Reset battery holder (including switch) and remote control.
	Remote too far away from battery holder (including switch).	- Refer to "wiring diagram" section in the Installation manual.
Flames are very aggressive.	Door is open.	- Ensure door is secured properly. If not rectified, contact a qualified technician.
Appliance won't perform any functions.	No power to the system.	- Check breaker to verify it's in the "on" position.
	Battery holder (including switch) in wrong position (if equipped).	- Verify that the 3 position switch on the battery holder (including switch) is in the remote position (middle).
	Battery holder, battery holder (including switch) and/or remote control isn't operational.	- Check battery power and battery orientation.

Napoleon products are manufactured under the strict Standard of the world recognized ISO 9001 : 2015 Quality Management System.

Napoleon products are designed with superior components and materials assembled by trained craftsmen who take great pride in their work. The burner and valve assembly are leak and test-fired at a quality test station. The complete appliance is again thoroughly inspected by a qualified technician before packaging to ensure that you, the customer, receive the quality product that you expect from Napoleon.

Napoleon Gas Appliance President's Lifetime Limited Warranty

The following materials and workmanship in your new Napoleon gas appliance are warranted against defects for as long as you own the appliance. This covers: combustion chamber, heat exchanger, stainless / steel burner, Phazer™ logs and embers, rocks, ceramic glass (thermal breakage only), gold plated parts against tarnishing, porcelainized enameled components and aluminum extrusion trims.*

Electrical (110V and millivolt) components and wearable parts are covered and Napoleon will provide replacement parts free of charge during the first year of the limited warranty. This covers: blowers, gas valves, thermal switches, switches, wiring, remote controls, ignitors, gaskets and pilot assemblies.*

Labour related to warranty repair is covered free of charge during the first year (labour warranty is not applicable for the Gas Log Sets). Repair work, however, requires the prior approval of an authorized company official. Labour costs to the account of Napoleon are based on a predetermined rate schedule and any repair work must be done through an authorized Napoleon dealer.

* Construction of models vary. Warranty applies only to components included with your specific appliance.

Conditions and Limitations

Napoleon warrants its products against manufacturing defects to the original purchaser only. Registering your warranty is not necessary. Simply provide your proof of purchase along with the model and serial number to make a warranty claim. Napoleon reserves the right to have its representative inspect any product or part thereof prior to honouring any warranty claim. Provided that the purchase was made through an authorized Napoleon dealer your appliance is subject to the following conditions and limitations:

Warranty coverage begins on the date of original installation. This factory warranty is non-transferable and may not be extended whatsoever by any of our representatives. The gas appliance must be installed by a licensed, authorized service technician or contractor qualified and authorized installer, service agency or supplier. Installation must be done in accordance with the installation instructions included with the product and all local and national building and fire codes. This limited warranty does not cover damages caused by misuse, lack of maintenance, accident, alterations, abuse or neglect, and parts installed from other manufacturers will nullify this warranty. This limited warranty further does not cover any scratches, dents, corrosion or discoloring caused by excessive heat, abrasive and chemical cleaners nor chipping on porcelain enamel parts, mechanical breakage of Phazer™ logs and embers. This warranty extends to the repair or replacement of warranted parts which are defective in material or workmanship provided that the product has been operated in accordance with the operation instructions and under normal conditions. After the first year, with respect to this President's Lifetime Limited Warranty, Napoleon may, at its discretion, fully discharge all obligations with respect to this warranty by refunding to the original warranted purchaser the wholesale price of any warranted but defective part(s).

After the first year, Napoleon will not be responsible for installation, labour, or any other expenses related to the reinstallation of a warranted part and such expenses are not covered by this warranty. Notwithstanding any provisions contained in the President's Lifetime Limited Warranty, Napoleon's responsibility under this warranty is defined as above and it shall not in any event extend to any incidental, consequential or indirect damages. This warranty defines the obligations and liability of Napoleon with respect to the Napoleon gas appliance and any other warranties expressed or implied with respect to this product, its components or accessories are excluded. Napoleon neither assumes, nor authorizes any third party to assume, on its behalf, any other liabilities with respect to the sale of this product. Napoleon will not be responsible for: over-firing, downdrafts, spillage caused by environmental conditions such as rooftops, buildings, nearby trees, hills, mountains, inadequate vents or ventilation, excessive venting configurations, insufficient makeup air, or negative air pressures which may or may not be caused by mechanical systems such as exhaust fans, furnaces, clothes dryers, etc. Any damages to the appliance, combustion chamber, heat exchanger, plated trim or other components due to water, weather damage, long periods of dampness, condensation, damaging chemicals or cleaners will not be the responsibility of Napoleon.

During the first 10 years Napoleon will replace or repair the defective parts covered by the lifetime warranty at our discretion free of charge. From 10 years to life, Napoleon will provide replacement parts at 50% of the current retail price. The manufacturer may require that defective parts or products be returned or that digital pictures be provided to support the claim. Returned products are to be shipped prepaid to the manufacturer for investigation. If a product is found to be defective, the manufacturer will repair or replace such defect. Before shipping your appliance or defective components, your dealer must obtain an authorization number. Any merchandise shipped without authorization will be refused and returned to sender. Shipping costs are not covered under this warranty. Additional service fees may apply if you are seeking warranty service from a dealer. Warranty labour allowance is only for the replacement of the warranted part. Travel, diagnostic tests, shipping and other related charges are not covered by this warranty.

All specifications and designed are subject to change without prior notice due to on-going product improvements. Napoleon is a registered trademark of Wolf Steel Ltd.

NAPOLEON CELEBRATING OVER 40 YEARS OF HOME COMFORT PRODUCTS



7200, Route Transcanadienne, Montréal, Québec H4T 1A3
24 Napoleon Road, Barrie, Ontario, Canada L4M 0G8
214 Bayview Drive, Barrie, Ontario, Canada L4N 4Y8
103 Miller Drive, Crittenden, Kentucky, USA 41030
De Riemsdijk 22, 4004 LC Tiel, The Netherlands

Phone: 1-866-820-8686
napoleon.com